

IRWIN[®]

TOOLS

CATALOGUE

2017



WISE-GRIP[®]

JACK

QUICK-GRIP[®]

Record[®]

Marples[®]

joran[®]

www.irwin.eu

INNOVATION MILESTONES

1885
Patent of
IRWIN® Auger
Charles Irwin formed
the IRWIN® Auger
Bit Co

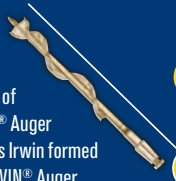

1828
MARPLES®
Chisels

1890
Solid Center
Auger



1914
HANSON®
Taps & Dies



1924
WISE-GRIP®
Locking Pliers



1954
SPEEDBOR®
Wood Boring
Spade Bits



1972
UNIBIT®
Step Drill Bits



2004
Bi-Metal Blades



2006
Blue Groove 6X
Wood Boring Bits



2009
QUICK-GRIP®
Bar Clamps



2011
WISE-GRIP®
Groovelock
Water Pump Pliers



2012
WISE-GRIP®
Fast Release
MARPLES®
Chisels



2014
JACK®
Plus
Handsaw Range
MARPLES®
& WELDTEC
Circular Saw Blades



2015
IMPACT
Screwdriving Bits
WISE-GRIP®
Performance Pliers



2016
RECORD®
Quick-Adjusting Vice



THE HISTORY OF IRWIN TOOLS

IRWIN Tools has a long and storied history, stretching for more than a century and set against the backdrop of a young, ambitious nation.

In 1885, Charles Irwin patented the Auger bit and, along with four business partners, formed the IRWIN Auger Bit Company. In 1924, William Petersen, a Danish immigrant, invented and patented VISE-GRIP® Locking Pliers. Through innovation and a series of acquisitions, these two companies have now become IRWIN Tools.

IRWIN Tools manufactures and distributes a broad line of hand tools and power tool accessories including JACK® handsaws, RECORD® clamping and locking tools, VISE-GRIP® pliers and wrenches, JORAN® drill bits, QUICK-GRIP® clamping tools, MARPLES® chisels and woodworking tools, and UNIBIT® drill bits.



IRWIN® innovation

Innovation is the hallmark of IRWIN®. For more than 100 years, it's been an idea that has permeated the culture of our company, and it continues to drive everything we do. Beginning in 1885 with development of the first IRWIN® auger bit, and progressing with the introduction of Vise-Grip® locking tools, Blue Groove flat bits, and Quick-Grip® bar clamps, IRWIN® has been at the forefront of the industry, creating better tools in a better way. Our impressive track record of new product development is born from our passion for understanding the needs of our primary user – the professional tradesman. This dedication to improving products begins in the field, where IRWIN®'s specialised end-user teams visit construction sites. There, the IRWIN® Field Product Specialist team learns first-hand – from the professional – how to improve our products, and how to make the pro's job easier and more productive. This hard-earned knowledge is the foundation for a unique product development process utilised by IRWIN®'s engineering, marketing, and manufacturing teams to deliver a continuous stream of new products to the marketplace. Supported by a global network of world-class manufacturing facilities and bolstered by our partnerships with leading global retailers, IRWIN® continuously sets the professional standard in each and every market segment in which we compete. From product feedback and development to distribution and use in the field, we dedicate ourselves to delivering quality tools that meet the stringent requirements of our toughest critics – professional tradesmen.



IRWIN® university

IRWIN® is committed to the pursuit of developing tools to get the job done right. Our commitment extends beyond our broad assortment of innovative IRWIN® products to include the development of our employees and valued customers. We are dedicated to delivering best-in-class career and industry development opportunities through a variety of product training programs.

INSTRUCTOR-LED PRODUCT TRAINING

The IRWIN® University is a state-of-the-art facility dedicated to IRWIN® product development and training. IRWIN® employees participate in a variety of multi-day training programs led by highly skilled facilitators to expand their knowledge of IRWIN® hand tools and power tool accessories. These hands-on courses range from introductory product knowledge overviews to more advanced curriculum including jobsite assessment, phases of construction, and hands-on, real-world product applications.



IRWIN® DESIGN CENTRES

IRWIN® has been delivering high-quality and innovative products for over a century. The experience and knowledge to design and build the IRWIN® products with rigorous testing and quality control are fundamental parts in our ability to offer the best products. Our testing centre facilities across the globe ensure exactly that.

The centres opposite use the very latest technology and testing methods within their specific areas of expertise.



IRWIN® new products for 2017



GOVERNMENTS

HAND TOOLS

04
Pliers & Wrenches



23
Metal Cutting



31
Woodworking



43
Workholding



64
Screwdrivers & Hex Keys



70
Utility Knives & Blades



78
Layout Tools



84
Tool Storage & Workwear



88
Plumbing Tools



POWER TOOL ACCESSORIES

92
Masonry Drilling

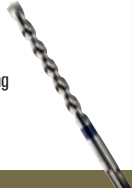

110
Metal Drilling



125
Wood Drilling



133
Drilling Sets



139
Fastener Drives & Screwdriving



150
Circular Saw Blades



162
Bi-Metal Hole Saws



164
Reciprocating Saw Blades



168
Jigsaw Blades



170
Index

IRWIN®



PLIERS & WRENCHES

WISE-GRIP®

The Vise-Grip® Locking Tool was invented in 1924 by a blacksmith in a small town of DeWitt, Nebraska. William Petersen was a Danish immigrant who invented the first locking pliers in his blacksmith shop, and began selling them from the back of his car to farmers and people in surrounding towns. He patented his new idea and called it VISE-GRIP®.

Since then, VISE-GRIP® has gained global brand recognition as the first choice for locking pliers. Innovation and quality are the core values of the VISE-GRIP® brand. With proven performance in every turn, these are the tools that tradespeople choose first – and pass on to the next generation.

The IRWIN® VISE-GRIP® family offers a full line of locking pliers, water pump pliers, cutting and VDE Pliers. IRWIN® VISE-GRIP® pliers and wrenches continue to set the standard for dependability, quality, and innovation today and tomorrow. Wherever there's a need for a quality tool, IRWIN® VISE-GRIP® is on the job.



Record®

Originally established in 1898 in the South Yorkshire city of Sheffield in the UK, the Record Tools Factory was swiftly able to make a long lasting contribution to the worldwide reputation of the region for the manufacture of high quality steel and castings.

The Record® brand name was introduced in 1909 and by the 1920's the product range had expanded into vices, planes, clamps and pipe wrenches enabling the business to grow rapidly in the UK and many overseas markets.

Today, IRWIN® Record® continues excelling by sticking to the traditional values set by its founders, producing tools that are highly valued amongst professional users for quality and durability that remains strong today.



LOCKING TOOLS



PLIERS



WRENCHES



LOCKING PLIERS

The Original

Since 1924™

IRWIN® VISE-GRIP® Original locking tools, with a classic guarded trigger release, are designed to provide maximum locking force.



Fast Release

IRWIN® VISE-GRIP® Fast Release locking pliers have a one-handed, triggerless release, so they're twice as easy to open as the traditional design. Plus, anti-pinch, non-slip ProTouch™ Grips provide comfort, control, and less hand fatigue.



SELF-ENERGISING LOWER JAW

UNIQUE CURVED JAW

PROTOUCH™ GRIPS

10CR FAST RELEASE LOCKING PLIER - THE PERFECT GRIP FOR ANY JOB.



BUILT STRONG TO LAST LONG

T11T

HEX KEY ADJUSTING SCREW



1. UNIQUE CURVED JAW

Great for securely gripping and torquing multiple surface shapes, including round pipes, square or hex bolts and more. Perfect for any application that requires maximum torque

2. SELF-ENERGISING LOWER JAW

Jaw mechanism provides 3X more gripping power*. Pivot allows jaw to align on workpiece for maximum grip without slipping or stripping

3. PROTOUCH™ GRIPS

Provides comfort, control and less hand fatigue

4. 2X LONGER LIFE*

High grade alloy steel is heat treated for maximum toughness and durability

5. HEX KEY ADJUSTING SCREW

Tightens to draw material closer together for tighter grip. Loosens to provide controlled release

3X MORE GRIPPING POWER*

2X LONGER LIFE*

ProTouch™ GRIPS

CURVED JAW LOCKING PLIERS

Self-energising lower jaw provides three times more gripping power, with no slipping or stripping on any style nut or bolt head.

T10T



10508017



| ITEM NO. | DESCRIPTION | CAPACITY | EAN | MASTER PACK | SHELF PACK |
|---------------------|--------------------------------|----------|---------------|-------------|------------|
| Fast Release | | | | | |
| T10T | Fast Release - 5CR 5"/ 125mm | 29mm | 5706915081459 | 25 | 5 |
| T13T | Fast Release - 7CR 7"/ 175mm | 38mm | 5706915081442 | 25 | 5 |
| T11T | Fast Release - 10CR 10"/ 250mm | 48mm | 5706915081435 | 25 | 5 |
| The Original | | | | | |
| 10508019 | Original - 5CR 5"/ 125mm | 29mm | 5706915080193 | 25 | 5 |
| 10508018 | Original - 7CR 7"/ 175mm | 38mm | 5706915080186 | 25 | 5 |
| 10508017 | Original - 10CR 10"/ 250mm | 48mm | 5706915080179 | 25 | 5 |

*vs. traditional locking pliers

STRAIGHT JAW LOCKING PLIERS

Straight jaw provides maximum contact on flat, square or hex materials.

| ITEM NO. | DESCRIPTION | CAPACITY | EAN | MASTER PACK | SHELF PACK |
|---------------------|-------------------------------|----------|---------------|-------------|------------|
| Fast Release | | | | | |
| T03T | FAST RELEASE - 7R 7"/ 175mm | 38mm | 5706915081800 | 25 | 5 |
| T01T | FAST RELEASE - 10R 10"/ 250mm | 48mm | 5706915081794 | 25 | 5 |
| The Original | | | | | |
| T0302EL4 | ORIGINAL - 7R 7"/ 175mm | 38mm | 38548003016 | 25 | 5 |
| T0102EL4 | ORIGINAL - 10R 10"/ 250mm | 48mm | 38548001067 | 25 | 5 |



T01T



T0102EL4

CURVED JAW LOCKING PLIERS WITH WIRE CUTTER

The curved jaw provides for a better fit around curved work shapes. Built-in wire cutter is great for a variety of applications and material shapes.

| ITEM NO. | DESCRIPTION | CAPACITY | EAN | MASTER PACK | SHELF PACK |
|---------------------|--------------------------------|----------|---------------|-------------|------------|
| Fast Release | | | | | |
| T09T | Fast Release - 5WR 5"/ 125mm | 29mm | 5706915081428 | 25 | 5 |
| T07T | Fast Release - 7WR 7"/ 175mm | 38mm | 5706915081411 | 25 | 5 |
| T05T | Fast Release - 10WR 10"/ 250mm | 48mm | 5706915081404 | 25 | 5 |
| The Original | | | | | |
| T1002EL4 | Original - 4WR 4"/ 100mm | 25mm | 38548001098 | 25 | 5 |
| T0902EL4 | Original - 5WR 5"/ 125mm | 29mm | 38548009063 | 25 | 5 |
| T0702EL4 | Original™ - 7WR 7"/ 175mm | 38mm | 38548007038 | 25 | 5 |
| T0502EL4 | Original - 10WR 10"/ 250mm | 48mm | 38548000510 | 25 | 5 |



T05T



T0902EL4

LONG NOSE LOCKING PLIERS WITH WIRE CUTTER

Long, straight nose provides easy access in narrow, hard-to-reach places.

| ITEM NO. | DESCRIPTION | CAPACITY | EAN | MASTER PACK | SHELF PACK |
|---------------------|-----------------------------|----------|---------------|-------------|------------|
| Fast Release | | | | | |
| T14T | Fast Release - 6LN 6"/15mm | 51mm | 5706915081466 | 25 | 5 |
| T15T | Fast Release - 9LN 9"/225mm | 70mm | 5706915081473 | 25 | 5 |
| The Original | | | | | |
| T1602EL4 | Original - 4LN 4"/100mm | 41mm | 38548001678 | 25 | 5 |
| T1402EL4 | Original - 6LN 6"/150mm | 51mm | 38548001432 | 25 | 5 |
| T1502EL4 | Original - 9LN 9"/225mm | 70mm | 38548001517 | 25 | 5 |



T15T



T1502EL4

LOCKING C-CLAMPS WITH REGULAR TIPS

Wide-opening jaw provides greater versatility in clamping a variety of shapes.

| ITEM NO. | DESCRIPTION | CAPACITY | EAN | MASTER PACK | SHELF PACK |
|---------------------|------------------------------|----------|---------------|-------------|------------|
| Fast Release | | | | | |
| 10507190 | Fast Release - 6R 6"/150mm | 54mm | 5706915071900 | 25 | 5 |
| 10507189 | Fast Release - 11R 11"/275mm | 102mm | 5706915071894 | 25 | 5 |
| The Original | | | | | |
| T17EL4 | Original - 6R 6"/150mm | 54mm | 38548001715 | 25 | 5 |
| T19EL4 | Original - 11R 11"/275mm | 102mm | 38548001913 | 25 | 5 |
| T18R | Original - 18R - 18"/455mm | 203mm | 38548000213 | - | 5 |
| T24R | Original - 24R - 24"/605mm | 254mm | 38548002750 | - | 5 |



10507189



T19EL4

LOCKING C-CLAMPS WITH DEEP THROAT

The large C-Clamp with greater throat capacity makes this a highly versatility versatile tool in the clamping of wider work-pieces.

| ITEM NO. | DESCRIPTION | CAPACITY | EAN | MASTER PACK | SHELF PACK |
|---------------------|-----------------------------------------------------|----------|-------------|-------------|------------|
| The Original | | | | | |
| T18DR | Original - 18DR Locking Clamp Deep Throat 18"/455mm | 190mm | 38548002118 | - | 5 |



T18DR



LOCKING C-CLAMPS WITH SWIVEL PADS

The swivelling pads and greater throat depth allow this clamp to hold irregular shapes and tapered work pieces.



T20EL4

| ITEM NO. | DESCRIPTION | CAPACITY | EAN | MASTER PACK | SHELF PACK |
|----------|-------------------------------------------|----------|-------------|-------------|------------|
| T165EL4 | Original - 4SP Locking C-Clamp 4"/100mm | 41mm | 38548001661 | 25 | 5 |
| T18EL4 | Original - 6SP Locking C-Clamp 6"/150mm | 54mm | 38548001845 | 25 | 5 |
| T9SP | Original - 9SP Locking C-Clamp 9"/225mm | 114mm | 38548003108 | 25 | 5 |
| T20EL4 | Original - 11SP Locking C-Clamp 11"/275mm | 102mm | 38548002019 | 25 | 5 |
| T18SP | Original - 18SP Locking C-Clamp 18"/455mm | 203mm | 38548000220 | - | 5 |
| T24SP | Original - 24SP Locking C-Clamp 24"/605mm | 254mm | 38548000282 | - | 5 |

LOCKING WRENCHES

The heavy-duty jaws lock onto three sides of hex fasteners and won't slip or mark workpieces.



4

| ITEM NO. | DESCRIPTION | CAPACITY | EAN | MASTER PACK | SHELF PACK |
|----------|------------------------------------------|----------|-------------|-------------|------------|
| 8 | Original - 4LW Locking Wrench 4"/100mm | 7-14mm | 38548002415 | 25 | 5 |
| 4 | Original - 7LW Locking Wrench 7"/175mm | 11-19mm | 38548000046 | 25 | 5 |
| 2 | Original - 10LW Locking Wrench 10"/250mm | 16-28mm | 38548000022 | 25 | 5 |

LARGE JAW LOCKING PLIERS

The heavy-duty jaws grip all shapes; ideal for plumbers, mechanics, welders and large jobs.



12L3

| ITEM NO. | DESCRIPTION | CAPACITY | EAN | MASTER PACK | SHELF PACK |
|----------|---------------------------------------------------|----------|-------------|-------------|------------|
| 12L3 | Original - 12LC Large Jaw Locking Plier 12"/300mm | 79mm | 38548012018 | 25 | 5 |

LOCKING SHEET METAL TOOL

The sheet metal tool makes bending, forming and crimping sheet metal easier.



23

| ITEM NO. | DESCRIPTION | CAPACITY | EAN | MASTER PACK | SHELF PACK |
|----------|-------------------------------------------------|----------|-------------|-------------|------------|
| 23 | Original - 8R Locking Sheet Metal Tool 8"/200mm | 78mm | 38548000237 | 25 | 5 |

LOCKING PINCH OFF TOOL

The pinch-off tool provides a temporary seal when applied to tubing, leaving both hands free for other work.



29

| ITEM NO. | DESCRIPTION | CAPACITY | EAN | MASTER PACK | SHELF PACK |
|----------|------------------------------------------------|----------|-------------|-------------|------------|
| 29 | Original - 7RR Locking Pinch-Off Tool 7"/175mm | 6mm | 38548000299 | 25 | 5 |

LOCKING PANEL CLAMP

The specially designed jaw provides quick clamping and alignment of automotive body panels.



251

| ITEM NO. | DESCRIPTION | CAPACITY | EAN | MASTER PACK | SHELF PACK |
|----------|---------------------------------------------|----------|-------------|-------------|------------|
| 251 | Original - 9AC Locking Panel Clamp 9"/225mm | 70mm | 38548002514 | 25 | 5 |

LOCKING WELDING CLAMP

The U-shape jaw provides enhanced visibility of the weld area and access to the weld space, allowing for more accurate alignment of both round and square shape tubing during welding.



25ZR

| ITEM NO. | DESCRIPTION | CAPACITY | EAN | MASTER PACK | SHELF PACK |
|----------|-----------------------------------------------|----------|-------------|-------------|------------|
| 25ZR | Original - 9R Locking Welding Clamp 9"/225 mm | 70 mm | 38548000251 | 25 | 5 |

PLIERS & WRENCHES

LOCKING CHAIN CLAMP

The chain holds and locks any shape or size up to 18"/455mm. Extension chains are available to extend to any length required.

| ITEM NO. | DESCRIPTION | EAN | MASTER PACK | SHELF PACK |
|----------|---------------------------------------------|---------------|-------------|------------|
| 27ZR | Original - 20R Locking Chain Clamp 9"/225mm | 0038548000275 | 10 | 5 |



LOCKING PLIERS SPARE PARTS

| ITEM NO. | DESCRIPTION | EAN | PCE PER PACK | MASTER PACK | SHELF PACK |
|----------|---------------------------------------------------------------------------------------------|---------------|--------------|-------------|------------|
| 2071910 | Adjusting Screw 5 Pc. - 10R, 10WR, 10CR, 20R, 12LC, 11R, 11SP, 18R, 18SP, 24R, 24SP, & 10LW | 0038548095455 | 5 | 100 | 5 |
| 4092 | Replacement spring 5pc - 4WR, 4LN, 4SP, 4LW | 0038548040929 | 5 | 100 | 5 |
| 4935309 | Replacement spring 5pc - 18R, 18SP, 24R, 24SP (box and packs marked 40-34) | 0038548040349 | 5 | 100 | 5 |
| 4008 | Replacement spring 5pc - 10R, 10WR, 10CR, 11R, 11SP, 20R, 12LC, 10LW | 0038548040080 | 5 | 100 | 5 |
| 4022ZR | Replacement spring 5pc - 7R, 7WR, 7CR, 9LN, 8R, RR, 7LW | 0038548040226 | 5 | 100 | 5 |
| 4052ZR | Replacement spring 5pc - 5WR, 6LN, 6R, 6SP | 0038548040523 | 5 | 100 | 5 |



LOCKING PLIERS SETS



T77T



T214T



T76KBT













10508020











T71

| ITEM NO. | DESCRIPTION | EAN | MASTER PACK | SHELF PACK |
|----------|---------------------------------------------------|---------------|-------------|------------|
| T77T | 2 pc. Fast Release - (10WR, 6LN) | 5706915081480 | 25 | 5 |
| T214T | 2 pc. Fast Release - (10WR, 7WR) | 5706915081497 | 25 | 5 |
| T76KBT | 3 pc. Fast Release - (10WR, 9LN, 7R) in kitbag | 5706915081503 | 25 | 5 |
| 10508020 | 3 pc. Original - (5CR, 7CR, 10CR) in storage tray | 5706915080209 | 25 | 5 |
| T71 | 4 pc. Original - (10CR, 7R, 6LN, 5WR), in kitbag | 0038548000718 | - | 5 |
| 4052ZR | Replacement spring 5pc - 5WR, 6LN, 6R, 6SP | 0038548040523 | 100 | 5 |

LOCKING PLIER RANGE OVERVIEW

| IMAGE | ITEM NO. | DESCRIPTION | SIZES | JAW CAPACITY | DESCRIPTION | RECOMMENDED APPLICATIONS | | | | |
|-------------------------------------------------------------------------------------|----------|------------------|-------------|----------------|------------------------------------------------------------------------------------------------------------------------------------------------------------------------------------------------------------------------------|---------------------------------------------------------|---------------------------------------------------------------------------------------------------------------------------------------------------------------------------------------------------------------------------------------------------------------------------------------------------------------------------------------------------------------------------------------------------|-------------------------------------------------|-------------------------------------------------------------------------------------------------------------------------------------------------------------------------------------------------------------------------------------------------------------------|------------------------------------------|
|  | T10T | 5CR 5" / 125mm | 5" / 125mm | 1-1/8" / 29 mm | CURVED JAW LOCKING PLIERS Great for securely gripping and torquing multiple surface shapes, including round pipes, square or hex bolts, and more. Perfect for any application that requires maximum torque. | Gripping Torque Rusted/Broken Screws | | | | |
| | T13T | 7CR 7" / 175mm | 7" / 175mm | 1-1/2" / 38 mm | | | | | | |
| | T11T | 10CR 10" / 250mm | 10" / 250mm | 1-7/8" / 48 mm | | | | | | |
|  | T0508019 | 5CR 5" / 125mm | 5" / 125mm | 1-1/8" / 29 mm | | | | | | |
| | T0508018 | 7CR 7" / 175mm | 7" / 175mm | 1-1/2" / 38 mm | | | | | | |
| | T0508017 | 10CR 10" / 250mm | 10" / 250mm | 1-7/8" / 48 mm | | | | | | |
|  | T03T | 7R 7" / 175mm | 7" / 175mm | 1-1/2" / 38 mm | | | STRAIGHT JAW LOCKING PLIERS The straight jaw pliers with heavy-duty jaws allow for maximum contact on all work shapes flat or square. It is very popular in welding and other metal work. Use for safer grinding or as a portable vice. The solid steel head makes this tool twice as strong as all other locking pliers. | Holding Welding Clamping | | |
| | T01T | 10R 10" / 250mm | 10" / 250mm | 1-7/8" / 48 mm | | | | | | |
|  | T0302EL4 | 7R 7" / 175mm | 7" / 175mm | 1-1/2" / 38 mm | | | | | | |
| | T0102EL4 | 10R 10" / 250mm | 10" / 250mm | 1-7/8" / 48 mm | | | | | | |
|  | T09T | 5WR 5" / 125mm | 5" / 125mm | 1-1/8" / 29 mm | CURVED JAW LOCKING PLIERS WITH WIRE CUTTER The curved jaw pliers provide for a better fit around curved work shapes. Curved jaw with built-in wire cutter great for a variety of applications and material shapes. | Wire Cutting Pulling, Prying Gripping | | | | |
| | T07T | 7WR 7" / 175mm | 7" / 175mm | 1-1/2" / 38 mm | | | | | | |
| | T05T | 10WR 10" / 250mm | 10" / 250mm | 1-7/8" / 48 mm | | | | | | |
|  | T1002EL4 | 4WR 4" / 100mm | 4" / 100mm | 1" / 25 mm | | | | | | |
| | T0902EL4 | 5WR 5" / 125mm | 5" / 125mm | 1-1/8" / 29 mm | | | | | | |
| | T0702EL4 | 7WR 7" / 175mm | 7" / 175mm | 1-1/2" / 38 mm | | | | | | |
| | T0502EL4 | 10WR 10" / 250mm | 10" / 250mm | 1-7/8" / 48 mm | | | | | | |
|  | T14T | 6LN 6" / 150mm | 6" / 150mm | 2" / 51 mm | | | | | LONG NOSE LOCKING PLIERS WITH WIRE CUTTER The long tapered nose plier is ideal for delicate work, hobbies, tight spaces, electronics and clamping of small parts. The long nose plier features a built in wire cutter which is helpful in tight spaces. | Reaching Bending Pinching |
| | T15T | 9LN 9" / 225mm | 9" / 225mm | 2-3/4" / 70 mm | | | | | | |
|  | T1602EL4 | 4LN 4" / 100mm | 4" / 100mm | 1-5/8" / 41 mm | | | | | | |
| | T1402EL4 | 6LN 6" / 150mm | 6" / 150mm | 2" / 51 mm | | | | | | |
| | T1502EL4 | 9LN 9" / 225mm | 9" / 225mm | 2-3/4" / 70 mm | | | | | | |
|  | T0507190 | 6R 6" / 150mm | 6" / 150mm | 2-1/8" / 54 mm | | | LOCKING C-CLAMPS WITH REGULAR TIPS The wide-opening jaws provide greater versatility in clamping projects than otherwise available with old fashioned clamps. The C-clamps with regular tips are very popular in welding, auto-body repair and other metal work. The fast release option allows users to move the clamps quickly with one hand while continuing to work with the other. | Fabricating Welding Construction | | |
| | T0507189 | 11R 11" / 275mm | 11" / 275mm | 4" / 102 mm | | | | | | |
|  | T17EL4 | 6R 6" / 150mm | 6" / 150mm | 2-1/8" / 54 mm | | | | | | |
| | T19EL4 | 11R 11" / 275mm | 11" / 275mm | 4" / 102 mm | | | | | | |
| | T18R | 18R 18" / 455mm | 18" / 455mm | 8" / 203 mm | | | | | | |
| | T24R | 24R 24" / 605mm | 24" / 254mm | 10" / 254 mm | | | | | | |

PLIERS & WRENCHES

| IMAGE | ITEM NO. | DESCRIPTION | SIZES | JAW CAPACITY | DESCRIPTION | RECOMMENDED APPLICATIONS |
|------------------------------------------------------------------------------------|----------|-------------------------------|-------------|-----------------|-----------------------------------------------------------------------------------------------------------------------------------------------------------------------------------------------------------------------------------------------------------------------------|-------------------------------------------------|
|  | T165EL4 | 4SP 4" / 100mm | 4" / 100mm | 1-5/8" / 41 mm | LOCKING C-CLAMPS WITH SWIVEL PADS The wide-opening jaws with swivel pads hold tapered work, awkward fabricating jobs and delicate projects. The C-Clamps with swivel pads are very popular in auto-body repair and other work on delicate or odd shaped surfaces. | Holding Delicate Seams |
| | T18EL4 | 6SP 6" / 150mm | 6" / 150mm | 2-1/8" / 54 mm | | |
| | T9SP | 9SP 9" / 225mm | 9" / 225mm | 4-1/2" / 114 mm | | |
| | T20EL4 | 11SP 11" / 275mm | 11" / 275mm | 4" / 102 mm | | |
| | T18SP | 18SP 18" / 455mm | 18" / 455mm | 8" / 203 mm | | |
| | T24SP | 24SP 24" / 605mm | 24" / 254mm | 10" / 254 mm | | |
|  | T9DR | 9DR 9" / 225mm | 9" / 225mm | 4-1/2" / 114 mm | LOCKING C-CLAMPS - DEEP THROAT These clamps have extra throat width and depth for greater clamping reach. These features allow for many clamping applications in welding, automotive and steel framing. | Fabricating Welding Construction |
| | T18DR | 18DR 18" / 455mm | 18" / 455mm | 7-1/2" / 190 mm | | |
|  | 23 | 8R 8" / 200mm | 8" / 200mm | 3-1/8" / 78 mm | LOCKING SHEET METAL TOOL The Locking Sheet Metal tool locks on to work with a powerful grip. The tool makes all kinds of bending, forming and crimping jobs easier and faster. | Bending Crimping Forming |
|  | 25ZR | 9R 8" / 225mm | 9" / 225mm | 2-3/4" / 70 mm | LOCKING WELDING CLAMP The Locking Welding Clamp has deep-throated and U-shaped jaws for visibility and working space. It holds work in proper alignment and is ideal for sheet metal work on automobiles. | Welding Holding |
|  | 27ZR | 20R 9" / 225mm | 9" / 225mm | 18" / 455 mm | LOCKING CHAIN CLAMP The Locking Chain Clamp holds and locks around any shape or any size of object and adjusts quickly for ratchet action in either direction. Extension chain is available. | Holding |
|  | 29 | RR 7" / 175mm | 7" / 175mm | 1/4" / 6 mm | LOCKING PINCH-OFF TOOL The Locking Pinch-Off tool with round jaws pinches and locks on tubing instantly without damaging the tubing. It is perfect to use for plumbing work, as it stops flow from untidy tubes. Very popular in the refrigeration market. | Holding |
|  | 251 | 9AC Locking Panel Clamp | 9" / 225mm | 2-3/4" / 70 mm | LOCKING PANEL CLAMP The jaws for the Locking Panel Clamp are designed to move in a straight line motion which allows the handle to be out of the way. Auto-body panels can be clamped in place and the door shut to check for gaps before final welding. | Clamping Welding |
|  | 8 | 4LW 4" / 100mm | 4" / 100mm | 7 mm - 14 mm | LOCKING WRENCH The jaws of the Locking Wrench lock on three sides of a bolt and will not slip or mark. The Locking Wrench is adjustable to over 16 wrench sizes and features a built-in wire cutter. | Pulling Tightening |
| | 4 | 7LW 7" / 175mm | 7" / 175mm | 11 mm - 19 mm | | |
| | 2 | 10LW 10" / 250mm | 10" / 250mm | 16 mm - 28 mm | | |
|  | 12L3 | 12LC 12" / 300mm | 12" / 300mm | 3-1/8" / 79 mm | LARGE JAW LOCKING PLIER The large jaws and clamping ability make this tool ideal for plumbers, mechanics, welders and others who work with large objects. Also, its convenient size makes it easier to use than bulkier tools, such as pipe wrenches. | Holding Clamping |



IRWIN®

WISE-GRIP®



GROOVELOCK WATER PUMP PLIERS WITH PROTOUCH™ GRIP

ALL-PURPOSE JAW

PRESS-N-SLIDE BUTTON

ANTI-PINCH NON-SLIP PROTOUCH GRIPS



MULTI-GROOVE RATCHETING SYSTEM

10507627

WATER PUMP PLIERS

GrooveLock Pliers are designed with twice the number of groove positions as traditional groove joint pliers to deliver optimal hand and jaw positioning - providing a superior grip. The specially engineered, all-purpose jaw grips round, hex, square and flat surfaces for incredible versatility.

- 1. ALL-PURPOSE JAW**
Grips onto flat, round, hex & square work pieces to provide tremendous bite
- 2. PRESS-N-SLIDE BUTTON**
Adjusts jaws 2X faster than traditional groove joint pliers
- 3. MULTI-GROOVE RATCHETING SYSTEM**
Has twice the groove positions than other groove joint pliers, for precise positioning on any type of work surface
- 4. ANTI-PINCH NON-SLIP PROTOUCH GRIPS**
Provide comfort, control and less hand fatigue

2X FASTER*
*vs traditional Groove Joint pliers

ProTouch
GRIPS

GrooveLock
Pliers

| ITEM NO. | DESCRIPTION | JAW CAPACITY | EAN | MASTER PACK | SHELF PACK |
|----------|-------------------------------------------|--------------|---------------|-------------|------------|
| 10507626 | GV6 GrooveLock PTG 6"/150mm | 29mm | 5706915076264 | 25 | 5 |
| 10507627 | GV8 GrooveLock PTG 8"/200mm | 45mm | 5706915076271 | 25 | 5 |
| 10507628 | GV10 GrooveLock PTG 10"/250mm | 57mm | 5706915076288 | 25 | 5 |
| 4935097 | GV10S GrooveLock PTG 10"/250mm Smooth Jaw | 57mm | 38548108629 | 25 | 5 |
| 10507629 | GV12 GrooveLock PTG 12"/300mm | 70mm | 5706915076295 | 20 | 5 |



GROOVELOCK WATER PUMP PLIERS WITH THIN GRIP

| ITEM NO. | DESCRIPTION | CAPACITY | EAN | MASTER PACK | SHELF PACK |
|----------|------------------------------|----------|---------------|-------------|------------|
| 10507630 | GV6 GrooveLock TG 6"/150mm | 29mm | 5706915076301 | 25 | 5 |
| 10507631 | GV8 GrooveLock TG 8"/200mm | 45mm | 5706915076318 | 25 | 5 |
| 10507632 | GV10 GrooveLock TG 10"/250mm | 57mm | 5706915076325 | 20 | 5 |
| 10507633 | GV12 GrooveLock TG 12"/300mm | 70mm | 5706915076332 | 25 | 5 |
| 2078116 | GV16 GrooveLock TG 16"/400mm | 114mm | 38548088099 | 10 | 2 |
| 2078120 | GV20 GrooveLock TG 20"/510mm | 152mm | 38548088105 | 5 | 1 |



WATER PUMP PLIERS

IRWIN® VISE-GRIP® Universal Water Pump pliers feature an all-purpose jaw, specially engineered to grip round, hex, square and flat surfaces. They are available with ProTouch™ grips (PTG) or thin grips (TG).

UNIVERSAL WATER PUMP PLIERS WITH PROTOUCH™ GRIP

| | ITEM NO. | DESCRIPTION | CAPACITY | EAN | MASTER PACK | SHELF PACK |
|-----------------------------------------------------------------------------------------------|----------|-------------------------------------------|----------|---------------|-------------|------------|
|  10507636 | 10507634 | Universal Water Pump Pliers PTG 6"/150mm | 29mm | 5706915076349 | 25 | 5 |
| | 10507635 | Universal Water Pump Pliers PTG 8"/200mm | 45mm | 5706915076356 | 25 | 5 |
| | 10507636 | Universal Water Pump Pliers PTG 10"/250mm | 57mm | 5706915076363 | 25 | 5 |
| | 10507637 | Universal Water Pump Pliers PTG 12"/300mm | 70mm | 5706915076370 | 25 | 5 |

UNIVERSAL WATER PUMP PLIERS WITH THIN GRIP

| | ITEM NO. | DESCRIPTION | CAPACITY | EAN | MASTER PACK | SHELF PACK |
|-----------------------------------------------------------------------------------------------|----------|------------------------------------------|----------|---------------|-------------|------------|
|  10507640 | 10507638 | Universal Water Pump Pliers TG 6"/150mm | 29mm | 5706915076387 | 25 | 5 |
| | 10507639 | Universal Water Pump Pliers TG 8"/200mm | 45mm | 5706915076394 | 25 | 5 |
| | 10507640 | Universal Water Pump Pliers TG 10"/250mm | 57mm | 5706915076400 | 25 | 5 |
| | 10507641 | Universal Water Pump Pliers TG 12"/300mm | 70mm | 5706915076417 | 25 | 5 |

GROOVE JOINT PLIERS

IRWIN® VISE-GRIP® Groove Joint pliers feature right angle teeth which grip in all directions for maximum bite. They all have moulded ProTouch™ grips for added comfort and less hand fatigue.

GROOVE JOINT PLIERS WITH PROTOUCH™ GRIPS

| | ITEM NO. | DESCRIPTION | CAPACITY | EAN | MASTER PACK | SHELF PACK |
|-------------------------------------------------------------------------------------------------|----------|------------------------------|----------|---------------|-------------|------------|
|  10505500 | 10505498 | Groove Joint Plier 8"/200mm | 38mm | 5706915054989 | 25 | 5 |
| | 10505500 | Groove Joint Plier 10"/250mm | 51mm | 5706915055009 | 25 | 5 |
| | 10505502 | Groove Joint Plier 12"/300mm | 57mm | 5706915055023 | 25 | 5 |

WISE-GRIP PLIERS

IRWIN® VISE-GRIP® traditional pliers have induction hardened cutting edges which stay sharp longer. The pliers also feature machined jaws for maximum gripping strength and moulded ProTouch™ grips for added comfort and less hand fatigue. TÜV/GS approvals demonstrate the high manufacturing standards of these VISE-GRIP® tools.

COMBINATION PLIERS

ProTouch™ GRIPS

TÜV SÜD GS

- MULTI-GRIP JAWS**
With maximum gripping groove design
- PROTOUCH™ GRIPS**
Are moulded for comfort and provide less hand fatigue
- INDUCTION HARDENED CUTTING FACE**
To stay sharper, longer
- CABLE CUTTER**
Up to Ø 1,6mm cables
- CHROMIUM NICKEL STEEL**
For improved durability on the gripping and cutting face

| ITEM NO. | DESCRIPTION | EAN | MASTER PACK | SHELF PACK |
|----------|----------------------------|---------------|-------------|------------|
| 10505875 | Combination Plier 6"/150mm | 5706915058758 | 25 | 5 |
| 1910231 | Combination Plier 7"/175mm | 5706915058772 | 25 | 5 |
| 10505876 | Combination Plier 8"/200mm | 5706915058765 | 25 | 5 |



DIAGONAL CUTTING PLIERS

Induction hardened cutting edges designed to stay sharper longer for wire cutting

| ITEM NO. | DESCRIPTION | EAN | MASTER PACK | SHELF PACK |
|----------|----------------------------------|---------------|-------------|------------|
| 10505493 | Diagonal Cutting Pliers 6"/150mm | 5706915054934 | 25 | 5 |
| 10505494 | Diagonal Cutting Pliers 7"/175mm | 5706915054941 | 25 | 5 |
| 10505495 | Diagonal Cutting Pliers 8"/200mm | 5706915054958 | 25 | 5 |



END CUTTING PLIERS

Throat clearance allows semi-flush cutting of nails and rivets

| ITEM NO. | DESCRIPTION | EAN | MASTER PACK | SHELF PACK |
|----------|-----------------------------|---------------|-------------|------------|
| 10505517 | End Cutting Pliers 8"/200mm | 5706915055177 | 25 | 5 |
| 10505518 | Cable Cutter 8"/200mm | 5706915055184 | 25 | 5 |



LONG NOSE PLIERS

Thin nose profile gets into tight spaces and is easier to reach around obstructions



10505504

| ITEM NO. | DESCRIPTION | EAN | MASTER PACK | SHELF PACK |
|----------|---------------------------|---------------|-------------|------------|
| 10505503 | Long Nose Pliers 6"/150mm | 5706915055030 | 25 | 5 |
| 10505504 | Long Nose Pliers 8"/200mm | 5706915055047 | 25 | 5 |

BENT NOSE PLIERS

Thin, angled nose profile gets into tight spaces and is easier to reach around obstructions



10505506

| ITEM NO. | DESCRIPTION | EAN | MASTER PACK | SHELF PACK |
|----------|---------------------------|---------------|-------------|------------|
| 10505505 | Bent Nose Pliers 6"/150mm | 5706915055054 | 25 | 5 |
| 10505506 | Bent Nose Pliers 8"/200mm | 5706915055061 | 25 | 5 |

NIPPER PLIERS

Throat clearance allows for semi-flush cutting



10508151

| ITEM NO. | DESCRIPTION | EAN | MASTER PACK | SHELF PACK |
|----------|--------------------------|---------------|-------------|------------|
| 10508153 | Nipper Plier TG 6"/150mm | 5706915081534 | 25 | 5 |
| 10508152 | Nipper Plier TG 7"/175mm | 5706915081527 | 25 | 5 |
| 10508151 | Nipper Plier TG 8"/200mm | 5706915081534 | 25 | 5 |

CONSTRUCTION NIPPERS

Precision-machined jaws and induction hardened cutting edge provide a clean cut



10508154

| ITEM NO. | DESCRIPTION | EAN | MASTER PACK | SHELF PACK |
|----------|----------------------------------|---------------|-------------|------------|
| 10508154 | Construction Nippers TG 9"/225mm | 5706915081541 | 25 | 5 |

NAIL PULLERS

Machined jaws provide maximum gripping strength



10508157

| ITEM NO. | DESCRIPTION | EAN | MASTER PACK | SHELF PACK |
|----------|--------------------------|---------------|-------------|------------|
| 10508156 | Nail Puller TG 10"/250mm | 5706915081565 | 25 | 5 |
| 10508157 | Nail Puller TG 8"/200mm | 5706915081572 | 25 | 5 |

TRADITIONAL PLIER SET



10505483

| ITEM NO. | DESCRIPTION | EAN | MASTER PACK | SHELF PACK |
|----------|-----------------------------------------------------------------------------------------------------|---------------|-------------|------------|
| 10505483 | ProPliers 3pcs Set (6"/150mm Diagonal Cutter, 8"/200mm Long Nose Plier, 7"/175mm Combination Plier) | 5706915054835 | 5 | 5 |



WHAT IS TÜV & GS?

- GUARANTEED SAFETY TO DIN STANDARDS
- PROVEN QUALITY & RELIABILITY

PLIERS & WRENCHES

ADJUSTABLE WRENCHES

IRWIN® VISE-GRIP® wrenches have scales in metric and imperial, and are available with ProTouch™ Grip for added comfort. TÜV/GS approvals demonstrate the high manufacturing standards of the VISE-GRIP® sub-brand. Parallel jaws with smooth surfaces assist a secure grip and help prevent scratches.

ADJUSTABLE WRENCH WITH PROTOUCH GRIP

| ITEM NO. | DESCRIPTION | CAPACITY | EAN | MASTER PACK | SHELF PACK |
|----------|---------------------------------|---------------|---------------|-------------|------------|
| 10505486 | Adjustable Wrench PTG 6"/150mm | 1"/25mm | 5706915054866 | 25 | 5 |
| 10505488 | Adjustable Wrench PTG 8"/200mm | 1-1/8" / 28mm | 5706915054880 | 25 | 5 |
| 10505490 | Adjustable Wrench PTG 10"/250mm | 1-1/4" / 31mm | 5706915054903 | 25 | 5 |
| 10505492 | Adjustable Wrench PTG 12"/300mm | 1-1/2" / 38mm | 5706915054927 | 20 | 5 |



10505492

ADJUSTABLE WRENCH WITH STEEL HANDLE

| ITEM NO. | DESCRIPTION | CAPACITY | EAN | MASTER PACK | SHELF PACK |
|----------|------------------------------------------|---------------|---------------|-------------|------------|
| 10508161 | Adjustable Wrench Steel Handle 6"/150mm | 1" / 25mm | 5706915081619 | 20 | 5 |
| 10508160 | Adjustable Wrench Steel Handle 8"/200mm | 1-1/8" / 28mm | 5706915081602 | 20 | 5 |
| 10508159 | Adjustable Wrench Steel Handle 10"/250mm | 1-1/4" / 31mm | 5706915081596 | 20 | 5 |
| 10508158 | Adjustable Wrench Steel Handle 12"/300mm | 1-1/2" / 38mm | 5706915081589 | 20 | 5 |



10508160



WHAT IS TÜV & GS?

- GUARANTEED SAFETY TO DIN STANDARDS
- PROVEN QUALITY & RELIABILITY

All Products on this page are TÜV/GS certified for optimal safety and user confidence.

ProTouch
GRIPS



VDE PLIERS

CROSS-HATCHED
JAWS

CABLE CUTTER

INDUCTION HARDENED
CUTTING FACE

PROTOUCH™ GRIPS

VDE COMBINATION PLIERS

IRWIN® Vise-Grip® VDE Pliers are fully TÜV, GS and VDE certified, meaning they are guaranteed safe for working with electrical equipment up to AC 1000V or DC 1500V. Their induction hardened cutting edges stay sharp longer, and their machined jaws are designed for maximum gripping strength. Plus, their ProTouch™ grips provide extra comfort for less hand fatigue.

1. CROSS-HATCHED JAWS

Maximum gripping

2. PROTOUCH™ GRIPS

For comfort and reduced hand fatigue

3. INDUCTION HARDENED CUTTING FACE

Stays sharper longer

4. CABLE CUTTER

Up to Ø 1.6mm cables

5. CHROMIUM NICKEL STEEL

For improved durability on the gripping and cutting face



10505874

| ITEM NO. | DESCRIPTION | EAN | MASTER PACK | SHELF PACK |
|----------|---------------------------------|---------------|-------------|------------|
| 10505872 | VDE Combination Pliers 6"/150mm | 5706915058727 | 25 | 5 |
| 10505873 | VDE Combination Pliers 7"/175mm | 5706915058734 | 25 | 5 |
| 10505874 | VDE Combination Pliers 8"/200mm | 5706915058741 | 25 | 5 |

VDE LONG AND BENT NOSE PLIERS

Thin nose profile gets into tight spaces, easy to reach around obstructions



10505869



10505870

| ITEM NO. | DESCRIPTION | EAN | MASTER PACK | SHELF PACK |
|----------|-------------------------------|---------------|-------------|------------|
| 10505868 | VDE Long Nose Pliers 6"/150mm | 5706915058680 | 25 | 5 |
| 10505869 | VDE Long Nose Pliers 8"/200mm | 5706915058697 | 25 | 5 |
| 10505870 | VDE Bent Nose Pliers 8"/200mm | 5706915058703 | 25 | 5 |



WHAT IS TÜV & GS?

- GUARANTEED SAFETY TO DIN STANDARDS
- PROVEN QUALITY & RELIABILITY

WHAT IS VDE

- SAFELY WORKING WITH ELECTRICAL EQUIPMENT UP TO AC OR DC 1500VOLT

All Products on this page are TÜV/GS certified for optimal safety and user confidence.

VDE DIAGONAL CUTTING PLIERS

Induction hardened cutting edges designed to stay sharper longer for wire cutting

| ITEM NO. | DESCRIPTION | EAN | MASTER PACK | SHELF PACK |
|----------|--------------------------------------|---------------|-------------|------------|
| 10505865 | VDE Diagonal Cutting Pliers 6"/150mm | 5706915058659 | 25 | 5 |
| 10505866 | VDE Diagonal Cutting Pliers 7"/175mm | 5706915058666 | 25 | 5 |
| 10505867 | VDE Diagonal Cutting Pliers 8"/200mm | 5706915058673 | 25 | 5 |



10505865

VDE WIRE STRIPPER

V-shape Cutters provide easy and precise wire stripping up to Ø 1,6 mm cables

| ITEM NO. | DESCRIPTION | EAN | MASTER PACK | SHELF PACK |
|----------|-----------------------------|---------------|-------------|------------|
| 10505871 | VDE Wire Strippers 6"/150mm | 5706915058710 | 25 | 5 |



VDE PLIERS SET

| ITEM NO. | DESCRIPTION | EAN | MASTER PACK | SHELF PACK |
|----------|-------------------------------------------------------------------------------------------|---------------|-------------|------------|
| 10505519 | 3pcs Set (6"/150mm diagonal cutter, 8"/200mm long nose plier, 7"/175mm combination plier) | 5706915055191 | 5 | 5 |



10505519



WHAT IS TÜV & GS?

- GUARANTEED SAFETY TO DIN STANDARDS
- PROVEN QUALITY & RELIABILITY

WHAT IS VDE

- SAFELY WORKING WITH ELECTRICAL EQUIPMENT UP TO AC OR CD1500VOLT

All Products on this page are TÜV/GS certified for optimal safety and user confidence.



IRWIN[®]

Record[®]



PIPE WRENCHES

IRWIN® Record® offer a full range of plumbing tools designed to get the job done quickly and efficiently. From our solid-forged Stillson Wrenches to the lightweight Quick-Adjusting Wrench, our range of pipe tools offer superior grip due to the unique 'V-shaped' tooth profile.

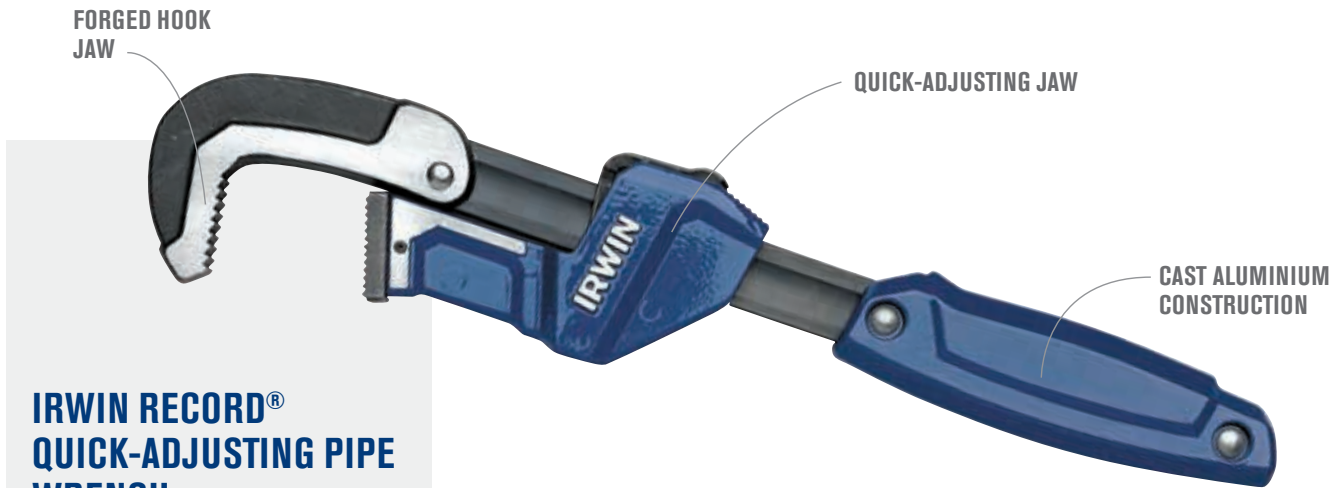

IRWIN RECORD® QUICK-ADJUSTING PIPE WRENCH

3X FASTER*

1. FORGED HOOK JAW

With 2-1/4" (58mm) jaw capacity equivalent to standard 14" (350mm) pipe wrench; ideal for pipe diameters up to 1-1/2" (38mm); ideal for most surfaces including black, galvanized, PVC and copper pipe, as well as nuts, bolts and couplings; broached teeth

2. QUICK-ADJUSTING JAW

With one-handed operation, ratchets quickly to work the surface

3. CAST ALUMINIUM CONSTRUCTION

40% less weight than standard 14" (350mm) cast iron pipe wrench; ergonomic handle is ideal for heavy torque and maximum comfort



| ITEM NO. | DESCRIPTION | CAPACITY | EAN | MASTER PACK | SHELF PACK |
|----------|------------------------|----------|---------------|-------------|------------|
| 10503642 | Quick-Adjusting Wrench | 3 - 58mm | 5706915036428 | - | 5 |



STILLSON PIPE WRENCHES

Solid forged handle and jaw with One Piece Unbreakable (S.G.) iron.

| ITEM NO. | DESCRIPTION | CAPACITY | EAN | MASTER PACK | SHELF PACK |
|----------|---------------------------|---------------|--------------|-------------|------------|
| T3008 | Stillson Wrench 8"/200mm | 3/4" / 19mm | 734442111122 | - | 6 |
| T30010 | Stillson Wrench 10"/250mm | 1" / 25mm | 734442111368 | - | 6 |
| T30012 | Stillson Wrench 12"/300mm | 1-1/4" / 32mm | 734442111603 | - | 6 |
| T30014 | Stillson Wrench 14"/350mm | 1-1/2" / 38mm | 734442111849 | - | 6 |
| T30018 | Stillson Wrench 18"/450mm | 2" / 51mm | 734442111962 | - | 6 |
| T30024 | Stillson Wrench 24"/600mm | 2-1/2" / 63mm | 734442112082 | - | 6 |
| T30036 | Stillson Wrench 36"/900mm | 3-1/2" / 89mm | 734442112204 | - | 6 |



STILLSON WRENCHES SPARE PARTS

| ITEM NO. | DESCRIPTION | EAN | MASTER PACK | SHELF PACK |
|----------|--------------------------------------|--------------|-------------|------------|
| T30018A | Jaw Complete with Nut (F) | 734442120605 | 1 | 4 |
| T30036A | Jaw Complete with Nut (F) | 734442121800 | 1 | 4 |
| T30018C | Frame with Pin (D) & Coil Spring (E) | 734442120841 | 1 | 4 |
| T30036C | Frame with Pin (D) & Coil Spring (E) | 734442122043 | 1 | 4 |
| T30024F | Nut (New Thread) | 734442117728 | 1 | 4 |
| T30036F | Nut | 734442119883 | 1 | 1 |

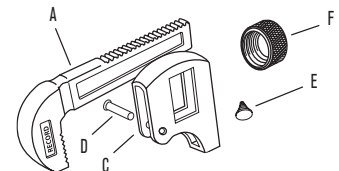

* Than traditional pipe wrenches

LEADER PIPE WRENCHES

Heavy-duty frame and handle are a one-piece ductile iron casting guaranteed against breakage.



T3508

| ITEM NO. | DESCRIPTION | CAPACITY | EAN | MASTER PACK | SHELF PACK |
|----------|--------------------------|---------------|--------------|-------------|------------|
| T3508 | Leader Wrench 8"/200mm | 1" (25mm) | 734442112440 | - | 4 |
| T35010 | Leader Wrench 10"/250mm | 1-1/2" (38mm) | 734442112563 | - | 4 |
| T35012 | Leader Wrench 12"/300mm | 2" (51mm) | 734442112327 | - | 4 |
| T35014 | Leader Wrench 14"/350mm | 2" (51mm) | 734442112686 | - | 4 |
| T35018 | Leader Wrench 18"/450mm | 2-1/2" (63mm) | 734442112808 | - | 4 |
| T35024 | Leader Wrench 24"/600mm | 3" (76mm) | 734442112921 | - | 1 |
| T35036 | Leader Wrench 36"/900mm | 5" (127mm) | 734442113041 | - | 1 |
| T35048 | Leader Wrench 48"/1220mm | 6" (152mm) | 734442113065 | - | 1 |

LEADER WRENCHES SPARE PARTS

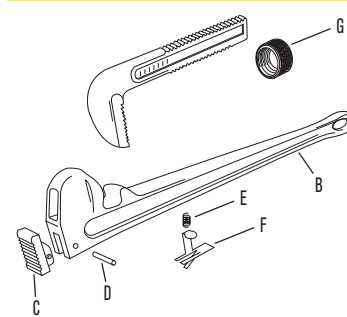

| ITEM NO. | DESCRIPTION | CAPACITY | EAN | MASTER PACK | SHELF PACK |
|----------|-----------------------------------|----------|--------------|-------------|------------|
| T35018A | Hook Jaw c/w Nut (G) | - | 734442125280 | 1 | 4 |
| T35024A | Hook Jaw c/w Nut (G) | - | 734442126126 | 1 | 4 |
| T35036A | Hook Jaw c/w Nut (G) | - | 734442126966 | 1 | 4 |
| T35048A | Hook Jaw c/w Nut (G) | - | 734442127802 | 1 | 4 |
| T35010C | Handle Jaw with Pin (D) | - | 734442123842 | 1 | 4 |
| T35018C | Handle Jaw with Pin (D) | - | 734442125402 | 1 | 1 |
| T35024C | Handle Jaw with Pin (D) | - | 734442126249 | 1 | 1 |
| T35048C | Handle Jaw with Pin (D) | - | 734442127925 | 1 | 1 |
| T35010E | Coil Spring (E) & Flat Spring (F) | - | 734442124085 | 1 | 1 |

HANDIWRENCH

Chain pipe wrenches are mainly used in confined spaces, such as against a wall or close to a nest of other piping. Simply loop the chain around the pipe, lock it and the jaws will grip in the direction of the turn. The pipe can then be easily tightened or loosened with short strokes of the handle.



| ITEM NO. | DESCRIPTION | CAPACITY | EAN | MASTER PACK | SHELF PACK |
|----------|------------------|------------|--------------|-------------|------------|
| T240 | HandiWrench Ø100 | 4" (101mm) | 734442113522 | 48 | 4 |

CHAIN PIPE WRENCHES



T235C

| ITEM NO. | DESCRIPTION | CAPACITY | EAN | MASTER PACK | SHELF PACK |
|----------|---------------------------------|-----------------------|--------------|-------------|------------|
| T23112 | Chain Pipe Wrench Ø61mm/14" | 5/16" - 2" / 8-51mm | 734442109082 | 12 | 1 |
| T23212 | Chain Pipe Wrench Ø90mm/21-1/2" | 5/16" - 3" / 8-76mm | 734442109204 | 12 | 1 |
| T233C | Chain Pipe Wrench Ø115mm/36" | 1/2" - 4" / 13-101mm | 734442113164 | 6 | 1 |
| T234C | Chain Pipe Wrench Ø220mm/51" | 1" - 8" / 25-203mm | 734442113287 | 6 | 1 |
| T235C | Chain Pipe Wrench 64-1/2" | 2" - 12" / 50 - 300mm | 734442114000 | 6 | 1 |

CHAIN PIPE WRENCHES REPLACEMENT CHAINS

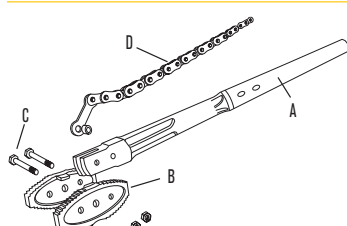

| ITEM NO. | DESCRIPTION | CAPACITY | EAN | MASTER PACK | SHELF PACK |
|----------|---------------------|----------|--------------|-------------|------------|
| T233CDB | Chain with Bush (D) | - | 734442113881 | 1 | 1 |
| T234CDB | Chain with Bush (D) | - | 734442114246 | 1 | 1 |

METAL CUTTING



HACKSAW BLADES

BI-METAL HACKSAW BLADES

IRWIN® high-quality hacksaw blades provide improved cutting performance. Their tooth geometry delivers higher resistance against tooth strippage and increases longevity and durability. Leveraging the advantages of WeldTec™ technology, IRWIN® hacksaw blades allow for faster, smoother and less tiring cutting.



- 1. WELDTEC TECHNOLOGY**
Innovative tooth geometry withstands wear and keeps the blade sharp for a long time
- 2. BI-METAL CONSTRUCTION**
Prevents blades from shattering and delivers long blade life

BI-METAL HACKSAW BLADES

| ITEM NO. | DESCRIPTION | EAN | MASTER PACK | SHELF PACK |
|----------|------------------------------------------------------------------|---------------|-------------|------------|
| 10504523 | Bi-Metal Hacksaw Blade 18TPI, 12" / 300mm, 2 pcs. | 5706915045239 | 90 | 1 |
| 10504524 | Bi-Metal Hacksaw Blade 24TPI, 12" / 300mm, 2 pcs. | 5706915045246 | 90 | 1 |
| 10504525 | Bi-Metal Hacksaw Blade 32TPI, 12" / 300mm 2 pcs. | 5706915045253 | 90 | 1 |
| 10507929 | Bi-Metal Hacksaw Blade 3pk (one each 18, 24 & 32TP), 12" / 300mm | 5706915079296 | 150 | 1 |
| 10505897 | Bi-Metal Hacksaw Blade 18TPI, 12" / 300mm, 10 pcs. | 5706915058970 | 50 | 1 |
| 10505898 | Bi-Metal Hacksaw Blade 24TPI, 12" / 300mm, 10 pcs. | 5706915058987 | 50 | 1 |
| 10505899 | Bi-Metal Hacksaw Blade 32TPI, 12" / 300mm, 10 pcs. | 5706915058994 | 50 | 1 |
| 10504520 | Bi-Metal Hacksaw Blade 18TPI, 12" / 300mm, 100 pcs. | 5706915045208 | 5 | 1 |
| 10504521 | Bi-Metal Hacksaw Blade 24TPI, 12" / 300mm, 100 pcs. | 5706915045215 | 5 | 1 |
| 10504522 | Bi-Metal Hacksaw Blade 32TPI, 12" / 300mm, 100 pcs. | 5706915045222 | 5 | 1 |
| 10504530 | Junior Hacksaw Wood Blade 14TPI, 6" / 150mm, 10 pcs. | 5706915045307 | 10 | 1 |
| 10504531 | Junior Hacksaw Wood Blade 32TPI, 6" / 150mm, 10 pcs. | 5706915045314 | 10 | 1 |



HACKSAW FRAMES

The IRWIN® Hacksaw frames are built to meet the professional's demanding needs. The durable IRWIN® frames make cutting quick and easy.

JAB SAW OPTION

I - 125 HIGH-TENSION HACKSAW (125kg/25,000 PSI)

The IRWIN® heavy-duty hacksaw frame is able to reach over 125kg blade tension to ensure accurate cutting. The soft-touch handle gives professionals a solid and slip-free grip.

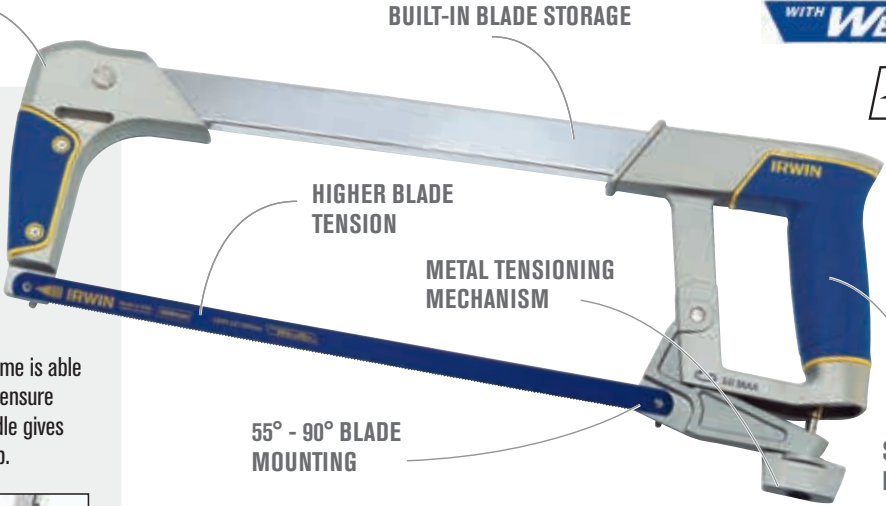

1. HIGHER BLADE TENSION
For straight cuts and prevents blade being released when dropped

2. METAL TENSIONING MECHANISM
For a longer lasting tool

3. SOFT TOUCH HANDLE
Ensure a comfortable sawing grip and prevents slippage

4. BUILT-IN BLADE STORAGE
So spare blades easily accessible

5. 55° - 90° BLADE MOUNTING
For sawing large objects

6. JAB SAW OPTION
For sawing in confined spaces

| ITEM NO. | DESCRIPTION | EAN | MASTER PACK | SHELF PACK |
|----------|--------------------------------------|---------------|-------------|------------|
| 10504407 | I-125 Hacksaw for 12" / 300mm blades | 5706915044072 | 10 | 10 |

I - 75 LOW TENSION HACKSAW (75kg/15,000 PSI)

This lightweight durable full metal frame - tensions up to 15,000 PSI with a full metal tensioning mechanism. 90° to 180° blade mounting is available for sawing large objects.

| ITEM NO. | DESCRIPTION | EAN | MASTER PACK | SHELF PACK |
|----------|-------------------------------------------------|---------------|-------------|------------|
| 10506437 | I-75 Low-Tension Hacksaw for 12" / 300mm blades | 5706915064377 | 10 | 10 |



MINI HACKSAW

Ergonomic handle for secure and comfortable cutting. Optimised for work in confined places.

| ITEM NO. | DESCRIPTION | EAN | MASTER PACK | SHELF PACK |
|----------|---------------------------------|---------------|-------------|------------|
| 10504408 | Mini Hacksaw, 10" / 250mm blade | 5706915044089 | 60 | 5 |



JUNIOR HACKSAW

Durable metal frame and easy tensioning mechanism allows for higher blade tension and improved cutting. The ergonomic handle delivers comfortable sawing.

| ITEM NO. | DESCRIPTION | EAN | MASTER PACK | SHELF PACK |
|----------|--------------------------------------|---------------|-------------|------------|
| 10504409 | Junior Hacksaw for 6" / 150mm Blades | 5706915044096 | 60 | 5 |



BOLT CUTTERS

IRWIN® Record® bolt cutters made their debut in 1923. IRWIN® Record® bolt cutters combine specially formulated steel jaws and exacting manufacturing techniques to make a range of cutters that will handle high, low and medium tensile materials of all kinds.

HEAVY-DUTY ARM-ADJUSTED DROP FORGED HANDLES – CENTRE CUT

Designed to withstand the most extreme situations, high-tensile drop-forged and ground steel jaws have also gone through a two-stage heat treatment to significantly increase durability and offer a stable cut capacity. Drop-forged steel handles provide safety and reliability and offer optimal performance for cutting high-tensile material.



TB918H

| EACH JAW IS PROGRESSIVELY HEAT TREATED to give a penetrating cutting edge and resilient body JAWS ARE DROP-FORGED from a specially formulated steel machined to precise specifications COMPOUND ACTION supplies 80lbs of force for every 1lb applied to the handles DROP-FORGED steel handles SAFETY STOPS prevent trapped fingers | ITEM NO. | DESCRIPTION | EAN | MASTER PACK | SHELF PACK |
|------------------------------------------------------------------------------------------------------------------------------------------------------------------------------------------------------------------------------------------------------------------------------------------------------------------------------------------------|----------|----------------------------------------|---------------------------------------|---------------|------------|
| | | T914H | Arm Adjusted Bolt Cutters 14" / 355mm | 0734442089162 | 10 |
| | T918H | Arm Adjusted Bolt Cutters 18" / 460mm | 0734442087489 | 10 | 1 |
| | T924H | Arm Adjusted Bolt Cutters 24" / 610mm | 0734442134046 | 4 | 1 |
| | T930H | Arm Adjusted Bolt Cutters 30" / 760mm | 0734442092643 | 2 | 1 |
| | T936H | Arm Adjusted Bolt Cutters 36" / 915mm | 0734442092766 | 2 | 1 |
| | T942H | Arm Adjusted Bolt Cutters 42" / 1070mm | 0734442092889 | 1 | 1 |

MEDIUM-DUTY CAM-ADJUSTED DROP FORGED HANDLES – CENTRE CUT

The cam adjusted bolt cutters are perfect for medium duty work on a daily basis. The drop-forged steel handles provide safe and reliable action along with specially formulated and heat-treated induction hardened steel heads.



TBC918H

| ITEM NO. | DESCRIPTION | EAN | MASTER PACK | SHELF PACK |
|----------|---------------------------------------|---------------|-------------|------------|
| TBC914H | Cam Adjusted Bolt Cutters 14" / 355mm | 0734442090847 | 10 | 1 |
| TBC918H | Cam Adjusted Bolt Cutters 18" / 460mm | 0734442092407 | 10 | 1 |
| TBC924H | Cam Adjusted Bolt Cutters 24" / 610mm | 0734442092520 | 4 | 1 |
| TBC930H | Cam Adjusted Bolt Cutters 30" / 760mm | 0734442092667 | 3 | 1 |
| TBC936H | Cam Adjusted Bolt Cutters 36" / 915mm | 0734442092780 | 2 | 1 |

GENERAL PURPOSE CAM-ADJUSTED TUBULAR HANDLES – CENTRE CUT

The cam adjusted high-tensile tubular handled bolt cutter are lightweight and easy to maintain. Great for help around the workshop, farm or garage.



TTBC918

| ITEM NO. | DESCRIPTION | EAN | MASTER PACK | SHELF PACK |
|----------|-------------------------------------------------------|---------------|-------------|------------|
| TTBC914 | Cam Adjusted Tubular Handled Bolt Cutters 14" / 355mm | 0734442089834 | 10 | 1 |
| TTBC918 | Cam Adjusted Tubular Handled Bolt Cutters 18" / 460mm | 0734442089841 | 8 | 1 |
| TTBC924 | Cam Adjusted Tubular Handled Bolt Cutters 24" / 610mm | 0734442089858 | 6 | 1 |
| TTBC930 | Cam Adjusted Tubular Handled Bolt Cutters 30" / 760mm | 0734442089896 | 4 | 1 |
| TTBC936 | Cam Adjusted Tubular Handled Bolt Cutters 36" / 915mm | 0734442089902 | 3 | 1 |

MEDIUM-DUTY CAM-ADJUST DROP FORGED HANDLES – END CUT

Designed for close cropping low-tensile and non-ferrous materials in confined spaces.



TBC924E

| ITEM NO. | DESCRIPTION | EAN | MASTER PACK | SHELF PACK |
|----------|----------------------------------------------|---------------|-------------|------------|
| TBC924E | Cam Adjusted Bolt Cutter -End Cut 24"/610 mm | 0734442093008 | 6 | 1 |

MEDIUM-DUTY CABLE CUTTERS

Drop-forged steel heads with long tubular handles for cutting a variety of wire and cable.

| ITEM NO. | DESCRIPTION | EAN | MASTER PACK | SHELF PACK |
|----------|------------------------------------------------------------|---------------|-------------|------------|
| TWC6 | Spring Handle Wire Cutter for Small, Solid and Strand Wire | 5011117175609 | 6 | 1 |
| TWC16 | Up to 16 mm Wire Rope & 21mm OD Armoured Electric Cable | 0734442175704 | 10 | 1 |
| TCC26 | Up to 26 mm Un-Armoured Copper & Aluminium Cable | 0734442176008 | 10 | 1 |



REPLACEMENT JAWS - CENTRE CUT

| ITEM NO. | DESCRIPTION | EAN | MASTER PACK | SHELF PACK |
|----------|--------------------------------------------------------------|---------------|-------------|------------|
| TJ914H | Replacement Jaw - Center Cut, Fits 14" / 355mm Bolt Cutters | 0734442094579 | - | 1 |
| TJ918H | Replacement Jaw - Center Cut, Fits 18" / 460mm Bolt Cutters | 0734442096009 | - | 1 |
| TJ924H | Replacement Jaw - Center Cut, Fits 24" / 610mm Bolt Cutters | 0734442096122 | - | 1 |
| TJ930H | Replacement Jaw - Center Cut, Fits 30" / 760mm Bolt Cutters | 0734442096245 | - | 1 |
| TJ936H | Replacement Jaw - Center Cut, Fits 36" / 915mm Bolt Cutters | 0734442096368 | - | 1 |
| TJ942H | Replacement Jaw - Center Cut, Fits 42" / 1070mm Bolt Cutters | 0734442096481 | - | 1 |



REPLACEMENT JAWS - CLIPPER CUT

| ITEM NO. | DESCRIPTION | EAN | MASTER PACK | SHELF PACK |
|----------|--------------------------------------------------------------|---------------|-------------|------------|
| TJ918F | Replacement Jaw - Clipper Cut, Fits 18" / 460mm Bolt Cutters | 0734442094685 | - | 1 |
| TJ924F | Replacement Jaw - Clipper Cut, Fits 24" / 610mm Bolt Cutters | 0734442094807 | - | 1 |
| TJ930F | Replacement Jaw - Clipper Cut, Fits 30" / 760mm Bolt Cutters | 0734442094920 | - | 1 |



REPLACEMENT JAWS - CLIPPER CUT

| ITEM NO. | DESCRIPTION | EAN | MASTER PACK | SHELF PACK |
|----------|----------------------------------------------|---------------|-------------|------------|
| TJ924E | Replacement Jaw - End Cut, Fits item TBC924E | 0734442097204 | - | 1 |



REPLACEMENT STRAP SETS

| ITEM NO. | DESCRIPTION | EAN | MASTER PACK | SHELF PACK |
|-----------|-------------------------------------------------------|---------------|-------------|------------|
| T914UEFGT | Replacement Strap Set, Fits 14" / 355mm Bolt Cutters | 0734442097938 | - | 1 |
| T918UEFGT | Replacement Strap Set, Fits 18" / 460mm Bolt Cutters | 0734442098058 | - | 1 |
| T924UEFGT | Replacement Strap Set, Fits 24" / 610mm Bolt Cutters | 0734442098652 | - | 1 |
| T930UEFGT | Replacement Strap Set, Fits 30" / 760mm Bolt Cutters | 0734442110057 | - | 1 |
| T936UEFGT | Replacement Strap Set, Fits 36" / 915mm Bolt Cutters | 0734442114857 | - | 1 |
| T942UEFGT | Replacement Strap Set, Fits 42" / 1070mm Bolt Cutters | 0734442108979 | - | 1 |



FASTENER KITS

| ITEM NO. | DESCRIPTION | EAN | MASTER PACK | SHELF PACK |
|-----------|-----------------------------------------|---------------|-------------|------------|
| T914KIT | Fastener Kit for item T914H | 0734442097945 | - | 1 |
| T918KIT | Fastener Kit for item T918H | 0734442089292 | - | 1 |
| T924KIT | Fastener Kit for item T924H | 0734442098669 | - | 1 |
| T930KIT | Fastener Kit for item T930H | 0734442104773 | - | 1 |
| T936KIT | Fastener Kit for item T936H | 0734442091455 | - | 1 |
| T942KIT | Fastener Kit for item T942H | 0734442108917 | - | 1 |
| TBC914KIT | Fastener Kit for item TBC914H & TTBC914 | 0734442090977 | - | 1 |
| TBC918KIT | Fastener Kit for item TBC918H & TTBC918 | 0734442090984 | - | 1 |
| TBC924KIT | Fastener Kit for item TBC924H & TTBC924 | 0734442169673 | - | 1 |
| TBC930KIT | Fastener Kit for item TBC930H & TTBC930 | 0734442010043 | - | 1 |
| TBC936KIT | Fastener Kit for item TBC936H & TTBC936 | 0734442101444 | - | 1 |

INCLUDES:

- 4 arm adjust screws
- 2 stud strap nuts
- 2 stud strap washers
- 1 handle connecting pin
- 1 handle connecting clip
- 2 handle connecting bolts,
- 2 handle connecting nuts
- 2 arm rivets
- 1 jaw center pin



SNIPS AND SHEARS

IRWIN® Gilbow® snips and shears have a cutting capability much greater than the strength of the user. The original tin snips were first designed in 1924 and have dominated the sheet metal cutting industry to such an extent that today, snips and shears are referred to as 'Gilbows'.

GENERAL PURPOSE SNIPS



TG24514

| UNIQUE NON-SLIP JOINT set and tested for a perfect cut. This should be re-adjusted only after sharpening DOUBLE, HOLLOW GROUND BLADES reduce friction for easier cutting DROP-FORGED carbon tool steel handles and blades SAFETY STOP prevents trapped fingers | ITEM NO. | DESCRIPTION | EAN | MASTER PACK | SHELF PACK |
|-----------------------------------------------------------------------------------------------------------------------------------------------------------------------------------------------------------------------------------------------------------------------------------------------------|----------|------------------------------------|---------------|-------------|------------|
| | TG2458 | General Purpose Snips, 8" / 200mm | 0734442188049 | 36 | 6 |
| | TG24510 | General Purpose Snips, 10" / 250mm | 0734442188162 | 36 | 6 |
| | TG24512 | General Purpose Snips, 12" / 300mm | 0734442188285 | 36 | 6 |
| | TG24514 | General Purpose Snips, 14" / 350mm | 0734442188407 | 36 | 6 |

CURVED BLADE SNIPS

Designed to complement the General Purpose range, these snips will make tight radius cuts in a clockwise or anti-clockwise direction.



TG24612

| ITEM NO. | DESCRIPTION | EAN | MASTER PACK | SHELF PACK |
|----------|---------------------------------|---------------|-------------|------------|
| TG2468 | Curved Blade Snips, 8" / 200mm | 0734442189008 | 48 | 6 |
| TG24610 | Curved Blade Snips, 10" / 250mm | 0734442189121 | 48 | 3 |
| TG24612 | Curved Blade Snips, 12" / 300mm | 0734442189244 | 48 | 3 |

JEWELLERS' SNIPS

Short-bladed light-duty snips often used by jewellers, silversmiths and model makers.



TG56

| ITEM NO. | DESCRIPTION | EAN | MASTER PACK | SHELF PACK |
|----------|---------------------------------------------|---------------|-------------|------------|
| TG56 | Jewellers' Snips, 7" / 175mm Straight Blade | 0734442190202 | 24 | 6 |
| TG056 | Jewellers' Snips, 7" / 175mm Curved Blade | 0734442187929 | 24 | 6 |

HEAVY-DUTY CRANKED HANDLE SHEARS

These crank-handled shears can be used for off-straight cutting. The G69 is right-hand cranked for working anti-clockwise and the G67 is left-hand cranked for working clockwise.



TG67

| ITEM NO. | DESCRIPTION | EAN | MASTER PACK | SHELF PACK |
|----------|-----------------------------------------------------------|---------------|-------------|------------|
| TG67 | Heavy-Duty Cranked Handle Snips, 11" / 175mm Left-Handed | 0734442189367 | 36 | 6 |
| TG69 | Heavy-Duty Cranked Handle Snips, 11" / 175mm Right-Handed | 0734442189480 | 36 | 6 |
| TG691 | Heavy-Duty Cranked Handle Snips, 14" / 350mm Right-Handed | 0734442189602 | 36 | 6 |

MEDIUM-DUTY STRAIGHT HANDLE SHEARS

Used for straight cutting.



TG950

| ITEM NO. | DESCRIPTION | EAN | MASTER PACK | SHELF PACK |
|----------|------------------------------------------------|---------------|-------------|------------|
| TG950 | Medium-Duty Straight Handle Snips, 12" / 300mm | 0734442189725 | 36 | 6 |
| TG69NB | Nut & Bolt for G67, G69, G950, G691 | 0734442195368 | - | 1 |

AVIATION AND OFFSET SNIPS

IRWIN® Aviation and Offset Snips have precision formed blades for a longer cutting life; ergonomically designed over-moulded soft-grips for a perfect balance of comfort and performance in the hand, and a long-life torsion spring for a smooth and consistent cut.

SERRATED LOWER BLADE

INCREASED LENGTH OF CUT

IMPROVED BALANCED WEIGHT DISTRIBUTION

AVIATION SNIPS

Serrated blade grips material for a smoother cut on thin material. Ideal for heating, air conditioning, gutter work and general industrial use.



DROP-RESISTANT PUSH-UP LATCH

PROTOUCH™ GRIPS

1. SERRATED LOWER BLADE

For firmer action, smoother cut and no double marked edges

2. PROTOUCH™ GRIPS

Moulded for superior comfort and control, resulting in less hand fatigue/stress

3. INCREASED LENGTH OF CUT

For faster work (3.34cm length of cut)

4. IMPROVED BALANCED WEIGHT DISTRIBUTION

For greater comfort

5. DROP-RESISTANT PUSH-UP LATCH

For easy one-handed use that saves time and increases safety

6. CUT CAPACITY OF 1.19 mm

For sheet metal and 0.84mm stainless steel

ProTouch
GRIPS



10504309N



10504310N



10504311N

| ITEM NO. | DESCRIPTION | EAN | MASTER PACK | SHELF PACK |
|-----------|---------------------------------------------|---------------|-------------|------------|
| 10504309N | Aviation Snip 101, Left and Straight Cut | 5706915043099 | - | 5 |
| 10504310N | Aviation Snip 102, Right and Straight Cut | 5706915043105 | - | 5 |
| 10504311N | Aviation Snip 103, Straight and Wide Curves | 5706915043112 | - | 5 |

BULLDOG SNIPS

Short blades designed for more power when notching and trimming thicker material. 225mm long with a 1.9 cm length of cut. Cut capacity of 16g/1.52 mm sheet metal and 18g/1.19 mm stainless steel.

| ITEM NO. | DESCRIPTION | EAN | MASTER PACK | SHELF PACK |
|-----------|---------------------------------------------|---------------|-------------|------------|
| 10504313N | Bulldog Snip 105, Straight and Short Curves | 5706915043136 | - | 5 |



10504313N



OFFSET SNIPS

For straight or curved cuts. Keeps hands safely above the work surface. 240mm long with a 3.02 cm length of cut. Cut capacity of 18g / 1.19 mm sheet metal and 22g / 0.84 mm stainless steel.



10504315N



10504316N



| ITEM NO. | DESCRIPTION | EAN | MASTER PACK | SHELF PACK |
|-----------|---------------------------------------------------|---------------|-------------|------------|
| 10504315N | Offset Snip 20SL, Straight, Angles & Left Curves | 5706915043150 | - | 5 |
| 10504316N | Offset Snip 20SR, Straight, Angles & Right Curves | 5706915043167 | - | 5 |

EXTRA CUT SNIPS

Designed for numerous applications when a long cut in lightweight material is desired. Compound leverage design provides cuts up to 80mm.



10504314N



| ITEM NO. | DESCRIPTION | EAN | MASTER PACK | SHELF PACK |
|-----------|-------------------------------------------------|---------------|-------------|------------|
| 10504314N | Extra Cut Snip 304 Cut Straight and Wide Curves | 5706915043143 | 25 | 5 |

WOODWORKING





In 1933, a young man by the name of Hans Schroder set up as a wholesaler in Copenhagen, Denmark. During the first few years he kept his focus on selling general hand tools, but in 1938 he started to also manufacture saws. Amongst his friends and business associates Hans Schroder was known simply as Jack, and before long, the "Jack" name had become synonymous with the production of high quality saws.

IRWIN® Jack® has been at the forefront of many advancements with the development of the market leading Jack® 880 now with upgraded ProTouch™ handle to compliment the recently upgraded universal triple ground tooth technology.



Marples®

At the heart of quality craftsmanship lies the rich heritage of Marples® woodworking tools. Originating in 1828 in Sheffield, England, the Marples® brand has consistently stood for superior performance and ultimate precision in fine woodworking.

Founder William Marples came from a long lineage of master craftsmen in the joinery and edge tool trades, and after serving as an apprentice to his father he established William Marples and Sons Limited. Using only the finest materials Marples® had his name stamped into every product as a sign of his confidence in the quality and craftsmanship of each tool.



HANDSAWS



CHISELS



WOODWORKING TOOLS



PLUS 880 UNIVERSAL HANDSAW

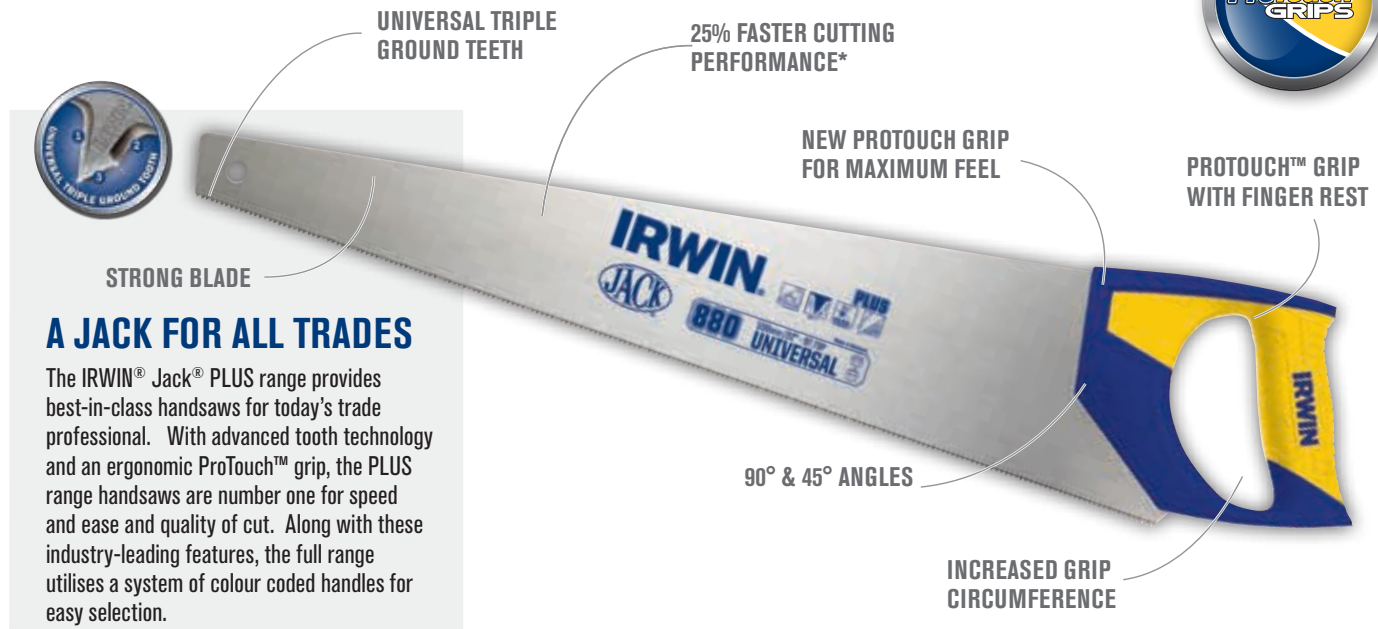

A JACK FOR ALL TRADES

The IRWIN® Jack® PLUS range provides best-in-class handsaws for today's trade professional. With advanced tooth technology and an ergonomic ProTouch™ grip, the PLUS range handsaws are number one for speed and ease and quality of cut. Along with these industry-leading features, the full range utilises a system of colour coded handles for easy selection.



- 1. UNIVERSAL TRIPLE GROUND TEETH**
Patented tooth grind designed to cut 25% faster
Versatile, universal teeth cut most building materials
- 2. STRONG BLADE**
High quality C75 steel is stable and ensures maximum power transfer with every stroke
- 3. PROTOUCH™ GRIP WITH FINGER REST**
With three times more elastomer for maximum soft-feel and control
- 4. OPTIMISED HAND CAPACITY**
Increased space for use with gloves and improved functionality
- 5. INCREASED GRIP CIRCUMFERENCE**
For a sturdy and robust feel
- 6. 90° & 45° ANGLES**
Integrated into handle for easy marking out

25% FASTER*

ProTouch GRIPS

880 UNIVERSAL HANDSAW

Ever-reliable cutting performance, improved handle design

| ITEM NO. | DESCRIPTION | HANDLE COLOUR | EAN | MASTER PACK | SHELF PACK |
|----------|------------------------------------|---------------|---------------|-------------|------------|
| 10503621 | Universal 880TG, 350mm / 14" 8T/9P | | 5706915936216 | - | 10 |
| 10503622 | Universal 880TG, 400mm / 16" 8T/9P | | 5706915936223 | - | 10 |
| 10503623 | Universal 880TG, 450mm / 18" 8T/9P | | 5706915936230 | - | 10 |
| 10503624 | Universal 880TG, 500mm / 20" 8T/9P | | 5706915936247 | - | 10 |
| 10503625 | Universal 880TG, 550mm / 22" 8T/9P | | 5706915936254 | - | 10 |

NEW PROTOUCH GRIP for maximum feel
25% FASTER CUTTING PERFORMANCE*
FULL RANGE of Fine, Universal, Coarse and Coated PLUS Handsaws Available
BLADE LENGTHS 14" / 20" / 22"

* vs previous, double ground version





UNIVERSAL COATED

BLADE LENGTH - 22"



FRICITION PTFE COATING

- A. Gives between 20 to 50% speed improvement (material dependent) when sawing
- B. Offers improved wear-resistance

| ITEM NO. | DESCRIPTION | HANDLE COLOUR | EAN | MASTER PACK | SHELF PACK |
|----------|-------------------------------------------|---------------|---------------|-------------|------------|
| 1909432 | Universal Coated 880TG, 550mm / 22" 8T/9P | | 5706919094325 | - | 10 |

COARSE

BLADE LENGTH - 22"



COARSE TEETH

- Patented Tooth Grind
- Double Ground
- 7 Teeth Per Inch

| ITEM NO. | DESCRIPTION | HANDLE COLOUR | EAN | MASTER PACK | SHELF PACK |
|----------|--------------------------------------------|---------------|---------------|-------------|------------|
| 1912454 | Crosscut / Coarse 660DG, 500mm / 20" 7T/8P | | 5706919124541 | - | 10 |
| 1912455 | Crosscut / Coarse 770DG, 550mm / 22" 7T/8P | | 5706919124558 | - | 10 |
| 10503628 | Crosscut / Coarse 660DG, 500mm / 20" 7T/8P | | 5706915936285 | - | 10 |
| 10503626 | Crosscut / Coarse 770DG, 550mm / 22" 7T/8P | | 5706915936261 | - | 10 |

FINE

BLADE LENGTH - 13" AND 22"



FINE TEETH

- Patented Tooth Grind
- Double Ground
- 9 Teeth Per Inch

| ITEM NO. | DESCRIPTION | HANDLE COLOUR | EAN | MASTER PACK | SHELF PACK |
|----------|----------------------------------------|---------------|---------------|-------------|------------|
| 10503632 | Ultra Fine 990, 325mm / 13" HP 12T/13P | | 5706915936322 | - | 10 |
| 1912456 | Fine 990DG, 500mm / 20" HP 9T/10P | | 5706919124565 | - | 10 |
| 1909433 | Ultra Fine 990, 325mm / 13" HP 12T/13P | | 5706919094332 | - | 10 |
| 10503630 | Fine 990DG, 500mm / 20" HP 9T/10P | | 5706915936308 | - | 10 |
| 10503631 | Fine 990DG 550mm / 22" 9T/10P | | 5706915936315 | - | 10 |

XPERT HANDSAWS

The XPERT saw range takes wood cutting to new levels of comfort and performance - with a specific saw for every material and application.



Triple-Ground Teeth (TGT). This technology has been developed in collaboration with the research centre of the University of Newcastle. The TGT logo is the mark of quality for the IRWIN® Jack® tooth design.



10505538



10505542



10505550



XPERT HANDSAWS

| ITEM NO. | DESCRIPTION | HANDLE COLOUR | EAN | MASTER PACK | SHELF PACK |
|----------|------------------------------------------------|---------------|---------------|-------------|------------|
| 10505538 | Universal Toolbox 15" / 375mm 8T/9P | Blue/Yellow | 5706915055382 | - | 10 |
| 10505539 | Universal 18" / 450mm 8T/9P | Blue/Yellow | 5706915055399 | - | 4 |
| 10505540 | Universal 20" / 500mm 8T/9P | Blue/Yellow | 5706915055405 | - | 4 |
| 10505541 | Universal 22" / 550mm 8T/9P | Blue/Yellow | 5706915055412 | - | 4 |
| 10505555 | Fine Toolbox 15" / 375mm 10T/11P | Blue/Yellow | 5706915055559 | - | 10 |
| 10505556 | Fine 20" / 500mm 10T/11P | Blue/Yellow | 5706915055566 | - | 4 |
| 10505543 | Fine 22" / 550mm 10T/11P | Blue/Yellow | 5706915055436 | - | 4 |
| 10505542 | Coarse with Gullets 22" / 550mm 8T/9P | Blue/Yellow | 5706915055429 | - | 4 |
| 10503530 | Coarse 20" / 500mm 3,5T/4P | Blue/Yellow | 5715110475802 | - | 4 |
| 10503531 | Coarse 24" / 600mm 3,5T/4P | Blue/Yellow | 5715110427191 | - | 4 |
| 10505548 | Light Concrete Hardpoint Teeth 28" / 700mm | Blue/Yellow | 5706915055481 | - | 4 |
| 10505549 | Light Concrete 1/2 Carbide Tipped 28" / 700mm | Blue/Yellow | 5706915055498 | - | 4 |
| 10505550 | Light Concrete FULL Carbide Tipped 28" / 700mm | Blue/Yellow | 5706915055504 | - | 4 |

TRIPLE-GROUND TEETH for ultimate cutting performance
HIGH QUALITY C75 STEEL, 1mm RIGID BLADE for maximum stability and power transfer
HARD POINT TEETH stay sharp longer for extended life
WATER BASED LACQUER gives four times better rust protection than traditional lacquer
SOFT-GRIP HANDLE with finger guide for comfort in prolonged use
DEEP GULLETS for enhanced performance and greater volume removal of waste material (Coarse saw only)
FINE NOSE TEETH for easy start (Universal and Toolbox Saw only)

XPERT COATED HANDSAWS

The Xpert range of low-friction PTFE coated handsaws from IRWIN® give between 20 to 50% speed improvement (material dependent) when sawing and also offer improved wear-resistance.

| ITEM NO. | DESCRIPTION | HANDLE COLOUR | EAN | MASTER PACK | SHELF PACK |
|----------|------------------------------------------|---------------|---------------|-------------|------------|
| 10505544 | Universal Toolbox PTFE 15"/375mm 8T/9P | Blue/Yellow | 5706915055443 | - | 10 |
| 10505545 | Universal PTFE 20"/500mm 8T/9P | Blue/Yellow | 5706915055450 | - | 4 |
| 10505546 | Universal PTFE 22"/550mm 8T/9P | Blue/Yellow | 5706915055467 | - | 4 |
| 10505602 | Fine PTFE 20"/500mm 10T/11P | Blue/Yellow | 5706915056020 | - | 4 |
| 10505603 | Fine PTFE 22"/550mm 10T/11P | Blue/Yellow | 5706915056037 | - | 4 |
| 10505547 | Coarse with gullets PTFE 22"/550mm 8T/9P | Blue/Yellow | 5706915055474 | - | 4 |



10505545

XPERT BOWSAWS

IRWIN® offers the complete range of bowsaws and replacement blades for pruning and garden work. Select from hard point and precision filed blades that give outstanding cutting performance, whether it's trimming storm-damaged trees, pruning shrubs, bushes or cutting firewood.

| ITEM NO. | DESCRIPTION | EAN | MASTER PACK | SHELF PACK |
|---------------|----------------------------------------|---------------|-------------|------------|
| FRAMES | | | | |
| TXP1624533000 | Bowsaw - Green Wood 21" / 533 mm | 5706915000269 | - | 5 |
| TXP1124610000 | Bowsaw - Green Wood 24" / 610 mm | 5706915000207 | - | 5 |
| TXP1124762000 | Bowsaw - Green Wood 30" / 762 mm | 5706915000221 | - | 5 |
| BLADES | | | | |
| TXP3011300000 | Bowsaw Blade - Dry Wood 12" / 300 mm | 5715110480066 | - | 10 |
| TXP3020533000 | Bowsaw Blade - Dry Wood 21" / 533 mm | 5715110480189 | - | 10 |
| TXP3020610000 | Bowsaw Blade - Dry Wood 24" / 610 mm | 5715110480219 | - | 10 |
| TXP3020762000 | Bowsaw Blade - Dry Wood 30" / 762 mm | 5715110480240 | - | 10 |
| TXP3024533000 | Bowsaw Blade - Green Wood 21" / 533 mm | 5715110480271 | - | 10 |
| TXP3024610000 | Bowsaw Blade - Green Wood 24" / 610 mm | 5715110480332 | - | 10 |
| TXP3024762000 | Bowsaw Blade - Green Wood 30" / 762 mm | 5715110480301 | - | 10 |



TXP1124762000



TXP3011300000



TXP3020533000



TXP3024533000

EVO HANDSAWS

The unique handle-to-blade relationship of the EVO handsaw overcomes traditional design limitations and maximises how the user interacts with the handsaw. With an innovative tooth design and superior ergonomics, the holistic product design optimises handle position (height and angle) against the tooth line. EVO covers virtually all user needs.

- HIGH ANGLED NOSE** increases blade stability
- HARD POINT TEETH (HP)** stay sharp 6-8 times longer than non-hardened teeth
- OPTIMISED TOOTH DESIGN & SET** provides maximum versatility, Speed of cut & quality of cut
- HIGH QUALITY C75 STEEL BLADE** ensures maximum stability and power transfer
- OPTIMISED PRODUCT DESIGN** for universal usage and highest versatility
- MAXIMUM BLADE USAGE** allows up to 100% blade usage
- FLUSH CUTTING** to cut off at surface level
- COMFORT GRIP** light and strong ultrasonic welded soft-grip handle for maximum grip and comfort
- 90° & 45°** for marking out
- FINGER-REST** for maximum control



| ITEM NO. | DESCRIPTION | HANDLE COLOUR | EAN | MASTER PACK | SHELF PACK |
|----------|----------------------------------------------|---------------|---------------|-------------|------------|
| 10507858 | EVO Handsaw Universal, 525mm 10T/11P | | 5706915078589 | - | 10 |
| 10507860 | EVO Handsaw Universal - Short, 425mm 10T/11P | | 5706915078602 | - | 10 |
| 1965487 | EVO Handsaw Universal Coated 485mm 10T/11P | | 5706919654871 | - | 10 |

SPECIALTY SAWS

IRWIN® Specialty saws help construction professionals effectively carry out trade specific jobs like cutting openings in gypsum board.



10503534



10505707



10503533

| ITEM NO. | DESCRIPTION | EAN | MASTER PACK | SHELF PACK |
|----------|-----------------------------------------------------------------|---------------|-------------|------------|
| 10505705 | ProTouch Jab Saw, 7T/8P | 5706915057058 | 24 | 4 |
| T106150 | Standard Jab Saw, 7T/8P | 5715110421601 | - | 20 |
| 10505707 | Protouch Dovetail Saw with reversible handle, 10"/254mm 13T/14P | 5706915057072 | 24 | 4 |
| 10503532 | Keyhole/Pad Saw, 12"/300mm | 5706915035322 | - | 4 |
| 10503533 | Floorboard/Veneer, 13"/325mm | 5706915035339 | - | 4 |
| 10507424 | Tenon, 10"/250mm 12T/13P | 5706915074246 | - | 4 |
| 10503534 | Tenon, 12"/300mm 12T/13P | 5706915035346 | - | 4 |
| 10503535 | Tenon, 14"/350mm 12T/13P | 5706915035353 | - | 4 |



10505705



T106150



10503532

PULL SAWS

IRWIN® Pull Saws are rapidly becoming an essential tool for both the specialist woodworker and for carpenters and re-modellers. The products offers a very thin blade that is flexible for flush and difficult cuts.



10505163



10505164



10505165

| ITEM NO. | DESCRIPTION | EAN | MASTER PACK | SHELF PACK |
|----------|-----------------------------------------------|---------------|-------------|------------|
| 10505162 | Pull Saw Carpenter 12"/300mm, 14TPI | 5706915051629 | - | 4 |
| 10505163 | Pull Saw Extra Fine Cut (with spine), 19TPI | 5706915051636 | - | 4 |
| 10505164 | Pull Saw Double Edge (rip/cross-cut), 7/17TPI | 5706915051643 | - | 4 |
| 10505165 | Pull Saw Mini Dovetail/Detail Saw, 22TPI | 5706915051650 | - | 4 |

PRUNING SAWS



TNA2059343000

| ITEM NO. | DESCRIPTION | EAN | MASTER PACK | SHELF PACK |
|---------------|------------------------|---------------|-------------|------------|
| TNA2059343000 | Pruning Saw - Straight | 5715110421632 | - | 6 |
| TNA2072330000 | Pruning Saw - Curved | 5715110421663 | - | 6 |

COMBI SAW

IRWIN® Jack® Combi Saw comes with a wood cutting bowsaw blade and a Bi-Metal cutting hacksaw blade making this tool universal for all cutting applications.



TXP1211300000

| ITEM NO. | DESCRIPTION | EAN | MASTER PACK | SHELF PACK |
|---------------|-----------------------|---------------|-------------|------------|
| TXP1211300000 | Combi Saw, 12"/300 mm | 5706915000122 | - | 10 |

WOODWORKING



CHISELS

IRWIN® woodworking tools embody a long tradition of craftsmanship and Marples® chisels remain the finest on the market, recognised by professionals as setting the standard for all others. With many unique features developed through continuing innovation, our comprehensive range of tough, dependable chisels will tackle the most intricate or demanding job effortlessly.

BEST IN CATEGORY STEEL QUALITY

BLADE HARDENED AND TEMPERED

PROTOCH™ OVER-MOULD GRIP

EXTRA LARGE STRIKE CAP

SPLITPROOF ACETATE HANDLE

MS750 HIGH-IMPACT CHISELS

- BEST IN CATEGORY STEEL QUALITY**
For improved sharpness and edge retention
- BLADE HARDENED AND TEMPERED**
For long chisel life
- FULLY FORGED STEEL CORE**
To better transfer energy from handle to blade
- PROTOCH™ OVER-MOULD GRIP**
For added comfort
- SPLITPROOF ACETATE HANDLE**
For superior durability
- EXTRA LARGE STRIKE CAP**
For use with hammers at different angles

MS750 SINGLES

| ITEM NO. | DESCRIPTION | EAN | MASTER PACK | SHELF PACK |
|----------|-------------|---------------|-------------|------------|
| 10501671 | MS750, 3mm | 0734442201250 | 48 | 4 |
| 10501673 | MS750, 6mm | 0734442201151 | 48 | 4 |
| 10501674 | MS750, 8mm | 5706915016741 | 48 | 4 |
| 10501675 | MS750, 10mm | 0734442201168 | 48 | 4 |
| 10501676 | MS750, 12mm | 5706915016765 | 48 | 4 |
| 10501678 | MS750, 14mm | 5706915016789 | 48 | 4 |
| 10501679 | MS750, 15mm | 5706915016796 | 48 | 4 |
| 10501680 | MS750, 16mm | 0734442201267 | 48 | 4 |
| 10501681 | MS750, 18mm | 5706915016819 | 48 | 4 |
| 10501683 | MS750, 20mm | 5706915016833 | 48 | 4 |
| 10501684 | MS750, 22mm | 5706915016840 | 48 | 4 |
| 10501685 | MS750, 25mm | 0734442201199 | 48 | 4 |
| 10501686 | MS750, 26mm | 5706915016864 | 48 | 4 |
| 10501687 | MS750, 28mm | 5706915016871 | 48 | 4 |
| 10501688 | MS750, 30mm | 5706915016888 | 48 | 4 |
| 10501689 | MS750, 32mm | 0734442201205 | 48 | 4 |
| 10501690 | MS750, 35mm | 5706915016901 | 48 | 4 |
| 10501691 | MS750, 38mm | 0734442201212 | 24 | 2 |
| 10501693 | MS750, 51mm | 0734442201274 | 24 | 2 |

MS750 SETS

| ITEM NO. | DESCRIPTION | EAN | MASTER PACK | SHELF PACK |
|----------|-------------------------------------------------------|---------------|-------------|------------|
| 10504711 | MS750, 3 pcs, 6, 12, 20 mm, Wallet | 5706915047110 | 16 | 4 |
| 10504712 | MS750, 3 pcs, 10, 15, 20 mm, Wallet | 5706915047127 | 16 | 4 |
| 10503733 | MS750, 6 pcs, 6, 10, 15, 20, 25, 35 mm, in Wooden Box | 5706915037333 | 5 | 1 |

MS751 FIRMER CHISEL

The MS751 Firmer chisel has a blade with a rectangular cross-section. This means that it is stronger and can be used for heavier work and cuts on a front edge.



10501768

| ITEM NO. | DESCRIPTION | EAN | MASTER PACK | SHELF PACK |
|----------|----------------------|---------------|-------------|------------|
| 10501768 | MS751, 1-1/8" / 28mm | 5706915017687 | 48 | 4 |

MS500 ALL-PURPOSE CHISELS WITH STRIKING CAP



10501708

MS500 SINGLES

| ITEM NO. | DESCRIPTION | EAN | MASTER PACK | SHELF PACK |
|----------|-------------|---------------|-------------|------------|
| 10501698 | MS500, 6mm | 5706915016987 | 48 | 4 |
| 10501699 | MS500, 8mm | 5706915016994 | 48 | 4 |
| 10501700 | MS500, 10mm | 5706915017007 | 48 | 4 |
| 10501701 | MS500, 12mm | 5706915017014 | 48 | 4 |
| 10501703 | MS500, 14mm | 5706915017038 | 48 | 4 |
| 10501704 | MS500, 15mm | 5706915017045 | 48 | 4 |
| 10501705 | MS500, 16mm | 5706915017052 | 48 | 4 |
| 10503666 | MS500, 18mm | 5706915036664 | 48 | 4 |
| 10501707 | MS500, 20mm | 5706915017076 | 48 | 4 |
| 10503667 | MS500, 22mm | 5706915036671 | 48 | 4 |
| 10501708 | MS500, 25mm | 5706915017083 | 48 | 4 |
| 10501709 | MS500, 26mm | 5706915017090 | 48 | 4 |
| 10503668 | MS500, 28mm | 5706915036688 | 48 | 4 |
| 10501710 | MS500, 30mm | 5706915017106 | 48 | 4 |
| 10503669 | MS500, 32mm | 5706915036695 | 48 | 4 |
| 10503423 | MS500, 35mm | 5706915034233 | 48 | 4 |
| 10503670 | MS500, 38mm | 5706915036701 | 24 | 2 |
| 10503425 | MS500, 51mm | 5706915034257 | 24 | 2 |

BEST IN CATEGORY STEEL QUALITY for improved sharpness and edge retention
BLADE HARDENED AND TEMPERED for long chisel life
PROTOUCH GRIP for added comfort
DURABLE HANDLE to withstand tradesmen abuse
LARGE STRIKE CAP to withstand hammer impacts

MS500 SETS

| ITEM NO. | DESCRIPTION | EAN | MASTER PACK | SHELF PACK |
|----------|-----------------------------------------------------|---------------|-------------|------------|
| 10503835 | MS500, 3 pcs, 6, 12, 20mm, Wallet | 5706915038354 | 16 | 4 |
| 10503836 | MS500, 3 pcs, 10, 15, 20mm, Wallet | 5706915038361 | 16 | 4 |
| 10503429 | MS500, 5 pcs, 6, 10, 15, 20, 25, Wallet | 5706915034295 | 16 | 8 |
| 10503876 | MS500, 5 pcs, 6, 10, 16, 20, 26, Wallet | 5706915038767 | 16 | 8 |
| 10503431 | MS500, 6 pcs, 6, 10, 12, 16, 20, 26mm in Wooden Box | 5706915034318 | 5 | 1 |
| 10503541 | MS500, 6 pcs, 6, 10, 15, 20, 25, 35mm in Wooden Box | 5706915035414 | 5 | 1 |



10503835



10503429



10503431

M444 BLUE-CHIP BEVEL EDGE CHISELS



M444 SINGLES

BEST IN CATEGORY STEEL QUALITY for improved sharpness and edge retention
BLADE HARDENED AND TEMPERED for long chisel life
CONTOURED HANDLE provides added control
STRONG HANDLE for use with hand or mallet

| ITEM NO. | DESCRIPTION | EAN | MASTER PACK | SHELF PACK |
|----------|-------------|---------------|-------------|------------|
| TM44418 | M444, 3mm | 0734442196440 | 24 | 6 |
| TM44414 | M444, 6mm | 0734442196563 | 24 | 6 |
| TM44438 | M444, 10mm | 0734442196686 | 24 | 6 |
| TM44412 | M444, 13mm | 0734442196808 | 24 | 6 |
| TM44458 | M444, 16mm | 0734442196921 | 24 | 6 |
| TM44434 | M444, 19mm | 0734442197041 | 24 | 6 |
| TM4441 | M444, 25mm | 0734442197164 | 24 | 6 |
| TM444114 | M444, 32mm | 0734442197287 | 24 | 6 |
| TM444112 | M444, 38mm | 0734442197409 | 24 | 6 |
| TM4442 | M444, 51mm | 0734442201960 | 24 | 6 |

M444 SETS



TM444S6

| ITEM NO. | DESCRIPTION | EAN | MASTER PACK | SHELF PACK |
|----------|---------------------------------------------------------|---------------|-------------|------------|
| TM444S3 | M444, 3 pcs Set - 13, 19, 25mm in clamshell | 0734442197508 | 16 | 4 |
| TM444S4 | M444, 4 pcs Set - 6, 13, 19, 25mm in clamshell | 0734442197522 | 16 | 4 |
| TM444S5 | M444, 5 pcs Set - 6, 10, 13, 19, 25mm in clamshell | 0734442197645 | 16 | 4 |
| TM444S6 | M444, 6 pcs Set - 6, 10, 13, 19, 25, 32mm in wooden box | 0734442197652 | 5 | 1 |



TM444S3



TM444S4



TM444S5

CHISEL SHARPENING SET



| ITEM NO. | DESCRIPTION | EAN | MASTER PACK | SHELF PACK |
|----------|----------------------------------------------------|---------------|-------------|------------|
| 10507932 | 3 pcs Sharpening Set includes Stone, Guide and Oil | 5706915079326 | 16 | 4 |

SQUARES AND SLIDING BEVELS

Sliding bevels are precision tools and are used for checking the accuracy and marking of angles. Tri Squares are designed to check and mark out 90° angles.

TRI & MITRE SQUARES - METRIC

| ITEM NO. | DESCRIPTION | EAN | MASTER PACK | SHELF PACK |
|----------|--------------------------|---------------|-------------|------------|
| 10503543 | Tri & Mitre Square 250mm | 5706915035438 | - | 4 |
| 10503544 | Tri & Mitre Square 300mm | 5706915035445 | - | 4 |
| 10503545 | Tri & Mitre Square 350mm | 5706915035452 | - | 4 |

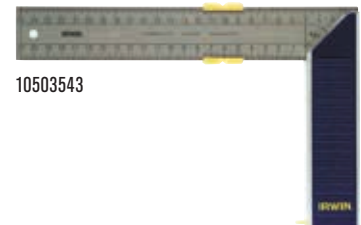

TRI & MITRE SQUARES - IMPERIAL

| ITEM NO. | DESCRIPTION | EAN | MASTER PACK | SHELF PACK |
|----------|--------------------------------|---------------|-------------|------------|
| TM22006 | Tri Square with Brass Plate 6" | 0734442231004 | 36 | 6 |
| TM220012 | Tri Square 12" | 0734442231240 | 36 | 6 |
| TMR22089 | Tri Square 9" | 0734442231486 | 48 | 6 |
| TM2210 | Mitre Square 10" | 0734442231608 | 36 | 1 |



SLIDING BEVELS - METRIC

| ITEM NO. | DESCRIPTION | EAN | MASTER PACK | SHELF PACK |
|----------|---------------------|---------------|-------------|------------|
| 10503546 | Sliding Bevel 250mm | 5706915035469 | - | 4 |
| 10503547 | Sliding Bevel 300mm | 5706915035476 | - | 4 |



SLIDING BEVELS - IMPERIAL

| ITEM NO. | DESCRIPTION | EAN | MASTER PACK | SHELF PACK |
|------------|-------------------------------------------|---------------|-------------|------------|
| TM2226 | Sliding Bevel - Brass & Rosewood, 9" | 0734442231844 | 48 | 4 |
| TM22261012 | Sliding Bevel - Brass & Rosewood, 10-1/2" | 0734442071167 | 48 | 4 |



GENERAL WOODWORKING TOOLS

These tools are an essential part of any workshop or toolbox. They all contribute to the final fit of the timber to ensure the highest quality finish.

BRADAWLS

| ITEM NO. | DESCRIPTION | EAN | MASTER PACK | SHELF PACK |
|----------|------------------------|---------------|-------------|------------|
| TM1838W | Bradawl Wooden Handled | 0734442234722 | 72 | 12 |



MORTICE, MARKING AND CUTTING GAUGES

| ITEM NO. | DESCRIPTION | EAN | MASTER PACK | SHELF PACK |
|----------|-----------------------------------------------|---------------|-------------|------------|
| TM2153 | Mortice & Marking Gauge | 0734442232322 | 24 | 4 |
| TM2154 | Mortice & Marking Gauge with thumbscrew slide | 0734442232445 | 12 | 1 |
| TMR2049 | Marking Gauge | 0734442231967 | 48 | 4 |
| TM2083 | Cutting Gauge | 0734442232209 | 24 | 4 |

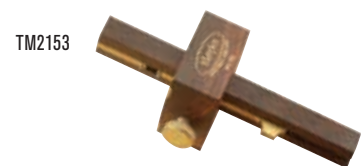

CABINET SCRAPERS

These versatile tools are used for shaping and finishing work.

| ITEM NO. | DESCRIPTION | EAN | MASTER PACK | SHELF PACK |
|----------|---------------------------------------------|---------------|-------------|------------|
| TM2450 | Cabinet Scraper, 5" x 2-1/2" / 125mm x 64mm | 0734442235309 | - | 6 |
| TM2451 | Cabinet Scraper, 6" x 3" / 150mm x 75mm | 0734442235316 | - | 6 |



PLANES & PLANE CUTTERS

IRWIN® Record® bring decades of experience, well proven design and advanced production techniques to produce this fine range of woodworking planes and cutters.

ROBUST LEVER
CAP

RAZOR SHARP CARBON
STEEL CUTTING IRON

FINE ADJUSTMENT

HIGH-QUALITY
CAST GREY IRON
BODY

BENCH PLANES

Smoothing Plane used for smoothing and final finishing. Jack planes are used for the preliminary squaring of rough timber, and are the general workhorses for stock removal. Fore or jointer planes are used for removing the roughness and unevenness on long surfaces prior to smoothing.



1. HIGH-QUALITY

Cast grey iron body with precision machined base

2. RAZOR SHARP

Carbon steel cutting iron

3. ROBUST LEVER CAP

Has three pressure points and brass locking nut for secure location of the cutting iron

4. FINE ADJUSTMENT

Is controlled by a brass adjusting nut and lateral adjusting lever



| ITEM NO. | DESCRIPTION | EAN | MASTER PACK | SHELF PACK |
|----------|------------------------------------------------------------------|---------------|-------------|------------|
| T04 | Smoothing Plane, 9-3/4" - 2" / 50mm, Wooden Handle | 0734442053408 | 24 | 1 |
| TSP4 | Smoothing Plane, 9-3/4" - 2" / 50mm, Plastic Handle | 0734442165729 | 48 | 4 |
| T05 | Jack Plane, 14" - 2" / 50mm, Wooden Handle | 0734442536482 | 24 | 1 |
| TSP5 | Jack Plane, 14" - 2" / 50mm, Plastic Handle | 0734442165910 | 48 | 4 |
| T07 | Jointer Plane, 22" - 2-3/8" / 60mm - length 550mm, Wooden Handle | 0734442054009 | 12 | 1 |

REBATE PLANE

Rebate plane has two cutter positions, one for normal rebating work and a forward position for planing into corners and difficult positions.



| ITEM NO. | DESCRIPTION | EAN | MASTER PACK | SHELF PACK |
|----------|----------------------------------------------------------------|---------------|-------------|------------|
| T778 | Rebate Plane, Length 8-1/2" - Cuts Rebates up to 1-1/2" / 38mm | 0734442559252 | 12 | 1 |

BLOCK PLANES

Block planes are fully adjustable for the depth of cut with mouth adjustments for coarse or fine work. Low angle block plane is specially made to deal with plastic, laminates, and other man-made materials, besides wood.



| ITEM NO. | DESCRIPTION | EAN | MASTER PACK | SHELF PACK |
|----------|---------------------------------------------------------|---------------|-------------|------------|
| T06012 | Block Plane, 6" (42mm) - 1-5/8" 12-1/2° - 20° low angle | 0734442552086 | 24 | 4 |
| T0912 | Block Plane, 6" (42mm) - 1-5/8" 12-1/2° | 0734442548430 | 24 | 4 |

SPOKESHAVES

The spokeshave is used for chamfering and shaping - flat-faced for convex surfaces and round-faced for concave surfaces.



| ITEM NO. | DESCRIPTION | EAN | MASTER PACK | SHELF PACK |
|----------|-----------------------------------------|---------------|-------------|------------|
| TA151 | Spokeshave, Flatface Length 10" / 54mm | 0734442056164 | 24 | 4 |
| TA151R | Spokeshave, Roundface Length 10" / 54mm | 0734442056287 | 24 | 4 |

REPLACEMENT PLANE CUTTERS



| ITEM NO. | DESCRIPTION | EAN | MASTER PACK | SHELF PACK |
|----------|--------------------------------------------------|---------------|-------------|------------|
| TSI2 | Plane Cutter, 2" / 50mm for 04, 05, SP4 & SP5 | 0734442056522 | 24 | 6 |
| TSI238 | Plane Cutter, 2-3/8" / 60mm for 06, 07 | 0734442056645 | 24 | 6 |
| T0220D | Plane Cutter, 2-3/8" / 46mm for 09-1/2 & 060-1/2 | 0734442057963 | 24 | 1 |
| T778D | Plane Cutter, for 778 | 0734442058809 | 24 | 1 |
| TA151B | Spokeshave Cutter, 2-1/8" / 54mm | 0734442058922 | 24 | 1 |

WORKHOLDING



QUICK-GRIP®

In 1986 Joe Sorensen, an air boat builder in Nebraska, USA was looking for a better way to hold down his steel panels as the clamps he was using twisted the thin steel as he worked.

With a good idea for a new style of clamping, the concept for a pistol grip one-handed bar clamp was born. This revolutionary tool was quickly patented and brought to market in 1989 with a full line of clamps under the QUICK-GRIP® brand name. The line was later extended from the Original clamp to the Micro, Mini, Handi, Quick-Change, and more recently the XP clamp.

Since the launch, IRWIN® Quick-Grip® has become the world leader in one-handed bar clamps and is the industry standard which has changed the way tradespeople do their jobs, greatly improving their ability and efficiency on the job.



Record®

Originally established in 1898 in the South Yorkshire city of Sheffield in the UK. The Record Tools Factory was swiftly able to make a long lasting contribution to the worldwide reputation of the region for the manufacture of high quality steel and castings.

The Record® brand name was introduced in 1909 and by the 1920's the product range had expanded into Vices, Planes, Clamps and Pipe Wrenches enabling the business to grow rapidly in the UK and many overseas markets.

Today, IRWIN® Record® continues excelling by sticking to the traditional values set by its founders, producing tools that are highly valued amongst professional users for quality and durability that remains strong today.



QUICK CLAMPS



STEEL CLAMPS



VICES

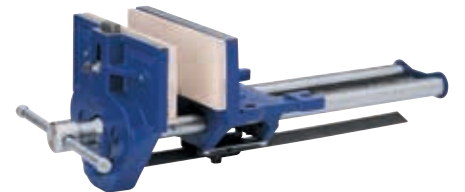

INTRODUCING THE NEXT GENERATION IN CLAMPING TOOLS

The new IRWIN® QUICK-GRIP® One-Handed Bar Clamp range allows end-users to be even more productive on the job. The new heavy-duty and medium-duty clamps feature a Quick-Change™ button for fast conversion to a spreader and for ease-of-use with a new line of One-Handed Bar Clamp Accessories.

These new IRWIN® QUICK-GRIP® One-Handed Bar Clamp Accessories provide added versatility and functionality to one-handed bar clamps—allowing users to DO MORE WITH QUICK-GRIP™.

HEAVY-DUTY ONE-HANDED BAR CLAMPS

NEW QUICK-CHANGE™
BUTTON

HEAVY-DUTY ONE-HANDED BAR CLAMPS

The IRWIN® QUICK-GRIP® Heavy-Duty One Handed Bar Clamp evenly distributes up to 272kg (600 lbs.) of sustained clamping pressure and is one of the top performing One-Handed Bar Clamps available. Ideal for heavy-duty applications such as installation, demolition and rough glue-up.



NEW REMOVABLE
SWIVEL JAWS &
NON-MARRING PADS

NEW



HEAT-TREATED, BLACK
OXIDE CARBON STEEL
I-BEAM

ADJUSTABLE
FOOT

ONE-HANDED QUICK-
RELEASE TRIGGER

- 1. NEW QUICK-CHANGE™ BUTTON**
Provides easy removal of jaws for accessory installation or conversion to a spreader
- 2. NEW REMOVABLE SWIVEL JAWS & NON-MARRING PADS**
Full-faced pads deliver even distribution of clamping force
- 3. ONE-HANDED QUICK-RELEASE TRIGGER**
New grip and trigger design provides simple, one-handed operation
- 4. HEAT-TREATED, BLACK OXIDE CARBON STEEL I-BEAM**
Support added pressure with less bend and flex for superior durability
- 5. ADJUSTABLE FOOT**
Provides added support allowing clamp to sit upright on table or work surface

272 kg

SUSTAINED CLAMPING FORCE

| ITEM NO. | DESCRIPTION | SPREADING CAPACITY | THROAT DEPTH | EAN | MASTER PACK | SHELF PACK |
|----------|--------------------------------------------|------------------------------------|---------------|---------------|-------------|------------|
| 10505942 | 150mm (6") Heavy-Duty Bar Clamp/Spreader | 235mm - 378mm 9-1/4" - 14-7/8" | 92mm / 3-5/8" | 5706915059427 | - | 2 |
| 10505943 | 300mm (12") Heavy-Duty Bar Clamp/Spreader | 235mm - 530mm 9-1/4" - 20-7/8" | 92mm / 3-5/8" | 5706915059434 | - | 2 |
| 10505944 | 450mm (18") Heavy-Duty Bar Clamp/Spreader | 235mm - 683mm 9-1/4" - 26-7/8" | 92mm / 3-5/8" | 5706915059441 | - | 2 |
| 10505945 | 600mm (24") Heavy-Duty Bar Clamp/Spreader | 235mm - 835mm 9-1/4" - 32-7/8" | 92mm / 3-5/8" | 5706915059458 | - | 2 |
| 10505946 | 900mm (36") Heavy-Duty Bar Clamp/Spreader | 235mm - 1140mm 9-1/4" - 44-7/8" | 92mm / 3-5/8" | 5706915059465 | - | 2 |
| 10505947 | 1250mm (50") Heavy-Duty Bar Clamp/Spreader | 235mm - 1496mm 9-1/4" - 58-7/8" | 92mm / 3-5/8" | 5706915059472 | - | 2 |



10505942

MEDIUM-DUTY ONE-HANDED BAR CLAMPS

NEW

NEW QUICK-CHANGE™ BUTTON

NEW REMOVABLE SWIVEL JAWS & NON-MARRING PADS



HEAT-TREATED, BLACK OXIDE CARBON STEEL I-BEAM

ONE-HANDED QUICK-RELEASE TRIGGER

MEDIUM-DUTY ONE-HANDED BAR CLAMPS

The IRWIN® QUICK-GRIP® Medium-Duty One-Handed Bar Clamp evenly distributes up to 136kg (300 lbs) of sustained clamping force. Ideal for temporary hold-down, quick clamping applications



- 1. NEW QUICK-CHANGE™ BUTTON**
Provides easy removal of jaws for accessory installation or conversion to a spreader
- 2. NEW REMOVABLE SWIVEL JAWS & NON-MARRING PADS**
Full-faced pads deliver even distribution of clamping force
- 3. ONE-HANDED QUICK-RELEASE TRIGGER**
New grip and trigger design provides simple, one-handed operation
- 4. HEAT-TREATED, BLACK OXIDE CARBON STEEL I-BEAM**
Support added pressure with less bend and flex for superior durability

136 kg
SUSTAINED CLAMPING FORCE



T506QCEL7

| ITEM NO. | DESCRIPTION | SPREADING CAPACITY | THROAT DEPTH | EAN | MASTER PACK | SHELF PACK |
|-----------|--------------------------------------------|------------------------------------|-----------------|---------------|-------------|------------|
| T506QCEL7 | 150mm (6") Medium-Duty Bar Clamp/Spreader | 200mm - 340mm 7-7/8" - 13-3/8" | 81 mm / 3-3/16" | 5706915000061 | - | 5 |
| T512QCEL7 | 300mm (12") Medium-Duty Bar Clamp/Spreader | 200mm - 590mm 7-7/8" - 19-3/8" | 81 mm / 3-3/16" | 5706915000078 | - | 5 |
| T518QCEL7 | 450mm (18") Medium-Duty Bar Clamp/Spreader | 200mm - 645mm 7-7/8" - 25-3/8" | 81 mm / 3-3/16" | 5706915000085 | - | 5 |
| T524QCEL7 | 600mm (24") Medium-Duty Bar Clamp/Spreader | 200mm - 795mm 7-7/8" - 31-3/8" | 81 mm / 3-3/16" | 5706915000092 | - | 5 |
| T536QCEL7 | 900mm (36") Medium-Duty Bar Clamp/Spreader | 200mm - 1120mm 7-7/8" - 43-3/8" | 81 mm / 3-3/16" | 5706915000108 | - | 5 |

MINI ONE-HANDED BAR CLAMP

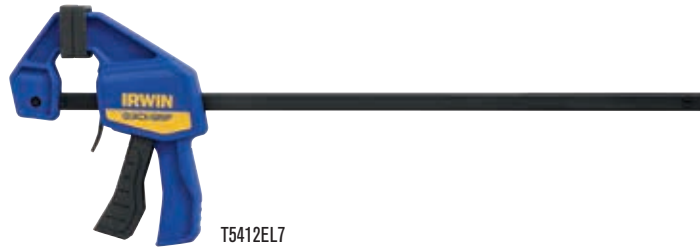

T5412EL7

NEW

| ITEM NO. | DESCRIPTION | THROAT DEPTH | EAN | MASTER PACK | SHELF PACK |
|-----------|---------------------------------|----------------|---------------|-------------|------------|
| T546EL7 | 150mm (6") Mini Clamp | 2-7/16" / 62mm | 5715110790585 | - | 5 |
| T5462EL7 | 150mm (6") Mini Clamp - 2 Pack | 2-7/16" / 62mm | 5715110790592 | - | 5 |
| T5412EL7 | 300mm (12") Mini Clamp | 2-7/16" / 62mm | 5715110790622 | - | 5 |
| T54122EL7 | 300mm (12") Mini Clamp - 2 Pack | 2-7/16" / 62mm | 5715110790639 | - | 5 |

EVENLY DISTRIBUTES UP TO 63kg (140 lbs.) of sustained clamping force
IDEAL FOR LIGHT-DUTY APPLICATIONS like woodworking and a variety of smaller projects
NON-MARRING FULL-FACE PADS protect work surfaces
ONE-HANDED QUICK-RELEASE™ TRIGGER

MICRO ONE-HANDED BAR CLAMP



T53006EL7

NEW

| ITEM NO. | DESCRIPTION | THROAT DEPTH | EAN | MASTER PACK | SHELF PACK |
|------------|-----------------------------------|----------------|---------------|-------------|------------|
| T53006EL7 | 115mm (4.5") Micro Clamp | 1-3/16" / 30mm | 5715110790547 | - | 10 |
| T530062EL7 | 115mm (4.5") Micro Clamp - 2 Pack | 1-3/16" / 30mm | 5715110801021 | - | 5 |

SPECIALLY DESIGNED for home, craft and hobby use providing 15kg (35 lbs.) of clamping pressure
IDEAL FOR DELICATE WORK requiring light clamping pressure
NON-MARRING FULL-FACE PADS protect work surfaces
ONE-HANDED QUICK-RELEASE™ TRIGGER

HANDI CLAMPS

Strong ratcheting mechanism provides variable clamping pressure 20kg (44 lbs). Quick-Release trigger allows for fast and easy positioning and release. The ideal clamp for jobs in workshop, house and garden. Specially designed jaws hold odd-shaped workpieces.

| ITEM NO. | DESCRIPTION | THROAT DEPTH | EAN | MASTER PACK | SHELF PACK |
|-----------|---------------------------|---------------|---------------|-------------|------------|
| T59100ECD | 38mm (1-1/4") Handi Clamp | 1-1/2" / 38mm | 0038548591001 | - | 20 |
| T59200ECD | 50mm (2") Handi Clamp | 2" / 50mm | 0038548592008 | - | 12 |
| T59400ECD | 100mm (4") Handi Clamp | 4" / 100mm | 0038548594002 | - | 10 |



T59200ECD

SPRING CLAMPS

High-tech resin construction provides strength and durability. Best for simple and convenient light clamping crafts.

| ITEM NO. | DESCRIPTION | THROAT DEPTH | EAN | MASTER PACK | SHELF PACK |
|-----------|------------------------|---------------|---------------|-------------|------------|
| T58100EL7 | 25mm (1") Spring Clamp | 1-1/2" / 38mm | 0038548581019 | 50 | 10 |
| T58200EL7 | 50mm (2") Spring Clamp | 2" / 50mm | 0038548582016 | 50 | 10 |
| T58300EL7 | 75mm (3") Spring Clamp | 3" / 75mm | 0038548582016 | 25 | 5 |



T58200EL7

REPLACEMENT PADS

| ITEM NO. | DESCRIPTION | EAN | MASTER PACK | SHELF PACK |
|----------|---------------------------------------------------------|---------------|-------------|------------|
| 1826576 | XP Pads, 2 per Pack (Previous Model HD Clamp) | 0038548998640 | - | 5 |
| 1826577 | Quick-Change Pads, 2 per Pack (Previous Model MD Clamp) | 0038548998657 | - | 5 |
| 1826578 | Mini Replacement Pads, 4 per Pack | 0038548998664 | - | 5 |
| 1826579 | Handi Clamp Replacement Pads, 6 per Pack | 0038548998671 | - | 5 |



1826576



1826577



ONE-HANDED BAR CLAMP ACCESSORIES

The new IRWIN® QUICK-GRIP® One-Handed Bar Clamps are designed to be compatible with the new line of One-Handed Bar Clamp Accessories. The chart below outlines which accessories fit which of the newly designed clamps and which accessories can also be used with the previous generation of IRWIN® QUICK-GRIP® One-Handed Bar Clamps.

DO MORE WITH QUICK-GRIP™



Edge Clamping



Wider Clamping Pressure



Corner Clamping



Table Clamping

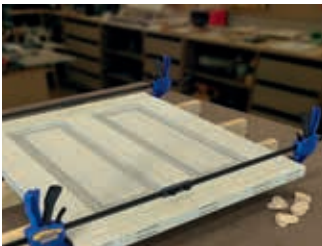

Coupling (Medium-Duty)

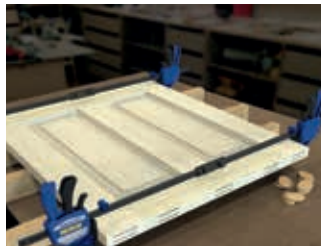

Coupling (Heavy-Duty)



Deck Building



Parallel Clamping

EDGE CLAMP



1988919

| ITEM NO. | DESCRIPTION | APPLICATION INFORMATION | EAN | MASTER PACK | SHELF PACK |
|----------|-------------|---------------------------------------------------------------------------------------|---------------|-------------|------------|
| 1988919 | Edge Clamp | Converts One-Handed Bar Clamp into an edge clamp for easy clamping of trim and edging | 5706919889198 | 40 | 5 |

COUPLERS



1988920



1988931

| ITEM NO. | DESCRIPTION | APPLICATION INFORMATION | EAN | MASTER PACK | SHELF PACK |
|----------|---------------------------|-----------------------------------------------------------------------------------|---------------|-------------|------------|
| 1988920 | Medium-Duty Clamp Coupler | Connects the bars of two shorter One-Handed Bar Clamps to create one longer clamp | 5706919889204 | 40 | 5 |
| 1988931 | Heavy-Duty Clamp Coupler | | 5706919889310 | 40 | 5 |

HOLD DOWN JIG



1988932

| ITEM NO. | DESCRIPTION | APPLICATION INFORMATION | EAN | MASTER PACK | SHELF PACK |
|----------|---------------|--------------------------------------------------|---------------|-------------|------------|
| 1988932 | Hold Down Jig | Converts One-Handed Bar Clamp into a table clamp | 5706919889327 | 40 | 5 |

WIDE PADS



1988933

| ITEM NO. | DESCRIPTION | APPLICATION INFORMATION | EAN | MASTER PACK | SHELF PACK |
|----------|-------------|------------------------------------------------------------------------------------------|---------------|-------------|------------|
| 1988933 | Wide Pads | Double the width of standard pads to distribute clamping force onto a wider surface area | 5706919889334 | 40 | 5 |

CORNER CLAMP

| ITEM NO. | DESCRIPTION | APPLICATION INFORMATION | EAN | MASTER PACK | SHELF PACK |
|----------|-------------------|-----------------------------------------------------------------------------------|---------------|-------------|------------|
| 1988935 | Corner Clamp Pads | Converts One-Handed Bar Clamp into a corner clamp for easy clamping of 90° angles | 5706919889358 | 40 | 5 |



DECK TOOL

| ITEM NO. | DESCRIPTION | APPLICATION INFORMATION | EAN | MASTER PACK | SHELF PACK |
|----------|---------------|-----------------------------------------------------------------------------------------------------------------------|---------------|-------------|------------|
| 1988934 | Deck Tool Kit | Converts One-Handed Bar Clamp into a deck clamp for easy, accurate spacing, aligning and holding during deck building | 5706919889341 | 40 | 5 |







CLAMP STAND

| ITEM NO. | DESCRIPTION | APPLICATION INFORMATION | EAN | MASTER PACK | SHELF PACK |
|----------|-------------|----------------------------------------------------------------------------------------------------------------------------------|---------------|-------------|------------|
| 1988936 | Clamp Stand | Converts One-Handed Bar Clamp for level clamping; ideal for parallel clamping applications such as frames, caseworks and drawers | 5706919889365 | 40 | 5 |



ACCESSORY SELECTION GUIDE

| SKU Code | Accessories | NEW | NEW | Quick-Change | XP |
|----------|---------------------------|-------------------------------------------------------------------------------------------------|------------------------------------------------------------------------------------------------|---------------------------------------------------------------------------------------|---------------------------------------------------------------------------------------|
| | | Medium-Duty  | Heavy-Duty  |  |  |
| 1988919 | Edge Clamp | ✓ | | ✓ | |
| 1988920 | Medium-Duty Clamp Coupler | ✓ | | ✓ | |
| 1988931 | Heavy-Duty Clamp Coupler | | ✓ | | ✓ |
| 1988932 | Hold Down Jig | ✓ | ✓ | ✓ | ✓ |
| 1988933 | Wide Pads | ✓ | ✓ | | |
| 1988934 | Deck Tool Kit | ✓ | | | |
| 1988935 | Corner Clamp Pads | ✓ | ✓ | | |
| 1988936 | Clamp Stand | ✓ | ✓ | ✓ | ✓ |



CLAMPING TOOLS SELECTION GUIDE

| CLAMPS & SPECS | ONE-HANDED BAR CLAMPS | | | | HANDI / SPRING CLAMPS | |
|--------------------------------------------------------------------|-----------------------|-----------------|--------------------------------------|--------------------------------------|-----------------------|--------------|
| | MICRO | MINI | MEDIUM-DUTY | HEAVY-DUTY | HANDI-CLAMP | SPRING CLAMP |
| Holding Force: | 15 kg / 35 lbs | 63 kg / 140 lbs | 136 kg / 300 lbs | 272 kg / 600 lbs | 20 - 40 kg | 15 - 30 kg |
| Clamp Capacity: | 115 mm | 150 - 300 mm | 150 - 900 mm | 150 - 1250 mm | 30 - 100 mm | 30 - 75 mm |
| Throat Depth: | 30mm (1-3/16") | 62mm (2-7/16") | 81 mm (3-3/16") | 92mm (3-5/8") | 38 - 100 mm | 30 - 75 mm |
| Spreading Capacity: | - | - | 200mm - 1120mm (7-7/8" - 43-3/8") | 235mm - 1496mm (9-1/4" - 58-7/8") | - | - |
| Crafts / light-duty clamping | ● | ● | ◐ | | ◐ | ○ |
| Temporary hold-down quick clamping | ● | ● | ● | ● | ◐ | ○ |
| Flat panels / Solid edge wood glue-up / Deep-reach clamping | | | | ◐ | | |
| Irregular shape / Multiple surface Corner joining | | | ◐ | ◐ | | |
| Installation / Demolition / Heavy-duty clamping | | | ◐ | ● | | |

○ = Good ◐ = Better ● = Best

WORKHOLDING



HEAVY-DUTY CLAMPING

IRWIN® Record® range of PRO clamps deliver the right fit, features and pressure for heavy-duty clamping jobs. Professionals will get the clamping performance they need to get the job done right.

IRWIN® RECORD® PRO CLAMP

THERMOPLASTIC ELASTOMERS (TPE) PADS

3-COMPONENT HANDLE

ZINC PLATED I-BEAM

ENHANCED PERFORMANCE

- 1. THERMOPLASTIC ELASTOMERS (TPE) PADS**
Pads snap fit to prevent loss and provide excellent friction to work surface while reducing marking
- 2. 3-COMPONENT HANDLE**
For higher torque transfer than wood, plus added comfort (L range has tommy bar)
- 3. ENHANCED PERFORMANCE**
Updated Rib location improves strength at less weight and allows the clamp to stand horizontally or vertically
- 4. ZINC PLATED I-BEAM**
Provides higher mechanical strength, less torsion and rust prevention

PRO CLAMP HOLDING PRESSURES COMPARISON

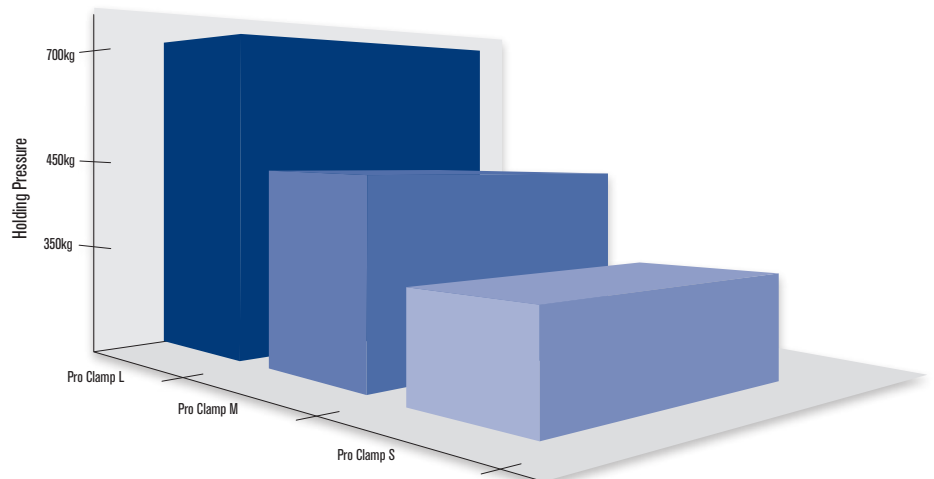

HEAVY-DUTY PRO CLAMP L WITH TOMMY BAR - CLAMPING DEPTH 140mm

Bar Dimension 35 x 9 mm

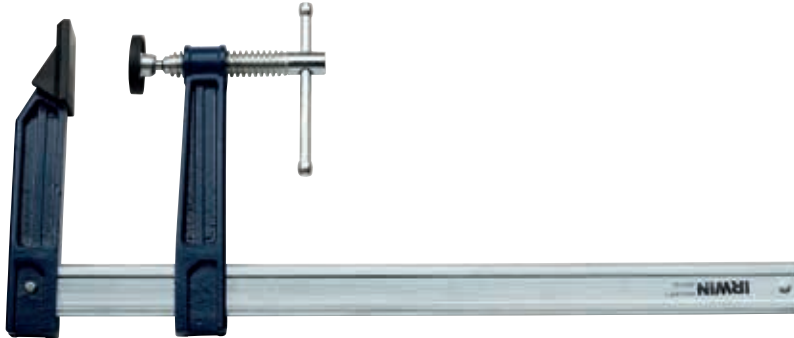

| ITEM NO. | DESCRIPTION | CLAMP CAPACITY | EAN | MASTER PACK | SHELF PACK |
|----------|---------------------|----------------|---------------|-------------|------------|
| 10503574 | Pro Clamp L, 400mm | 16" / 400mm | 5706915035742 | - | 3 |
| 10503575 | Pro Clamp L, 600mm | 24" / 600mm | 5706915035759 | - | 3 |
| 10503576 | Pro Clamp L, 800mm | 32" / 800mm | 5706915035766 | - | 3 |
| 10503577 | Pro Clamp L, 1000mm | 40" / 1000mm | 5706915035773 | - | 3 |
| 10503578 | Pro Clamp L, 1250mm | 50" / 1250mm | 5706915035780 | - | 3 |
| 10503579 | Pro Clamp L, 1500mm | 60" / 1500mm | 5706915035797 | - | 3 |



10503574

MEDIUM DUTY PRO CLAMP M - CLAMPING DEPTH 120mm

Bar Dimension 30 x 8 mm



| ITEM NO. | DESCRIPTION | CLAMP CAPACITY | EAN | MASTER PACK | SHELF PACK |
|----------|---------------------|----------------|---------------|-------------|------------|
| 10503569 | Pro Clamp M, 300mm | 12" / 300mm | 5706915035698 | - | 4 |
| 10503570 | Pro Clamp M, 400mm | 16" / 400mm | 5706915035704 | - | 4 |
| 10503571 | Pro Clamp M, 600mm | 24" / 600mm | 5706915035711 | - | 4 |
| 10503572 | Pro Clamp M, 800mm | 32" / 800mm | 5706915035728 | - | 4 |
| 10503573 | Pro Clamp M, 1000mm | 40" / 1000mm | 5706915035735 | - | 4 |



10503569

LIGHT DUTY PRO CLAMP S - CLAMPING DEPTH 80mm

Bar Dimension 25 x 6 mm



| ITEM NO. | DESCRIPTION | CLAMP CAPACITY | EAN | MASTER PACK | SHELF PACK |
|----------|--------------------|----------------|---------------|-------------|------------|
| 10503564 | Pro Clamp S, 200mm | 8" / 200mm | 5706915035643 | - | 4 |
| 10503565 | Pro Clamp S, 300mm | 12" / 300mm | 5706915035650 | - | 4 |
| 10503566 | Pro Clamp S, 400mm | 16" / 400mm | 5706915035667 | - | 4 |
| 10503567 | Pro Clamp S, 600mm | 24" / 600mm | 5706915035674 | - | 4 |
| 10503568 | Pro Clamp S, 800mm | 32" / 800mm | 5706915035681 | - | 4 |



10503565



T-BAR CLAMPS 136 SERIES AND SPARE PARTS

These clamps resist twisting and distortion under clamping pressures. Both the head and slide are guaranteed unbreakable. The slide is secured by a solid steel pin passing through one of the locating holes spaced along the steel bar. The steel mainscrew applies pressure quickly and smoothly through a fast acting, hard wearing rolled thread. Slides and heads are flat bottomed so that the clamp will stand without support.

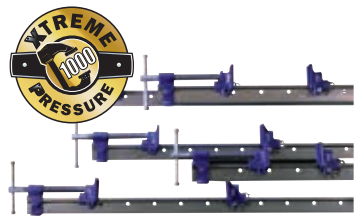

| ITEM NO. | DESCRIPTION | CLAMP CAPACITY | EAN | MASTER PACK | SHELF PACK |
|----------|------------------------------|----------------|---------------|-------------|------------|
| T1365 | T-Bar Clamp | 42" / 1070mm | 0734442034087 | - | 1 |
| T1366 | T-Bar Clamp | 48" / 1200mm | 0734442034209 | - | 1 |
| T1367 | T-Bar Clamp | 54" / 1350mm | 0734442034322 | - | 1 |
| T1369 | T-Bar Clamp | 66" / 1680mm | 0734442034445 | - | 1 |
| T13611 | T-Bar Clamp | 78" / 1980mm | 0734442034568 | - | 1 |
| TL1366 | 48" Lengthening Bar (1220mm) | - | 0734442034681 | - | 1 |
| T136D | Tailslide with Peg & Chain | - | 0734442046561 | - | 1 |

SASH CLAMPS 135 SERIES AND SPARE PARTS

These cut heavy-duty clamps have a bar section of 32mm x 6mm (1-1/4" x 1/4"). The slide and head are guaranteed unbreakable.

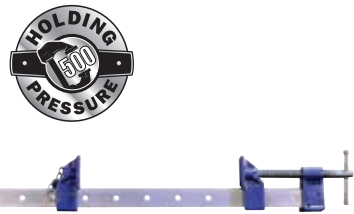

| ITEM NO. | DESCRIPTION | CLAMP CAPACITY | EAN | MASTER PACK | SHELF PACK |
|----------|-----------------------------------------|----------------|---------------|-------------|------------|
| T1352 | Sash Clamp | 24" / 610mm | 0734442033363 | - | 1 |
| T1353 | Sash Clamp | 30" / 760mm | 0734442033486 | - | 1 |
| T1354 | Sash Clamp | 36" / 915mm | 0734442033608 | - | 1 |
| T1355 | Sash Clamp | 42" / 1070mm | 0734442033721 | - | 1 |
| T1356 | Sash Clamp | 48" / 1220mm | 0734442033844 | - | 1 |
| T1357 | Sash Clamp | 54" / 1370mm | 0734442033851 | - | 1 |
| T1359 | Sash Clamp | 66" / 1980mm | 0734442033875 | - | 1 |
| TL1354 | Sash Clamp, 36" Lengthening Bar (915mm) | - | 0734442033967 | - | 1 |
| T135D | Tailslide with Peg & Chain | - | 0734442045366 | - | 1 |
| T135E | Peg & Chain | - | 0734442045960 | - | 1 |

CLAMP HEADS

Low cost alternative to full size bar clamps, the grey cast iron head and slide with steel mainscrew can be fitted to a wooden batten 25mm (1") thick by 38mm (1-1/2") wide and any length.

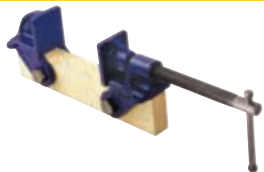

| ITEM NO. | DESCRIPTION | EAN | MASTER PACK | SHELF PACK |
|----------|-------------------------------------|---------------|-------------|------------|
| TM130 | Clamp Head, 1" x 1-1/2" / 25 x 38mm | 0734442348078 | - | 6 |

MITRE CUTTING CORNER CLAMPS

Accurate mitre clamping is provided by IRWIN® Record® Corner Clamps. The clamps have two countersunk holes for fixing to a wooden block, which can then be secured between the jaws of a bench vice. Thanks to the precision machined clamping surfaces and open design, these clamps are straight forward to operate and provide easy access for glueing and nailing.



| ITEM NO. | DESCRIPTION | CLAMP CAPACITY | EAN | MASTER PACK | SHELF PACK |
|----------|----------------------------------|----------------|---------------|-------------|------------|
| TM140 | Mitre Cutting Corner Clamp 50mm | 2" / 50mm | 0734442028444 | 24 | 1 |
| TM141 | Mitre Cutting Corner Clamp 100mm | 4-1/4" / 105mm | 0734442028404 | 24 | 1 |

FLOORING CLAMP

Designed to close up floor boards prior to nailing, this compact and robust clamp has two spring loaded cams which straddle the joist, holding the clamp firmly in position. Turning the handle then moves the shoe forward, pushing the floorboard into position. For standard 75mm (3") joists.



| ITEM NO. | DESCRIPTION | CLAMP CAPACITY | EAN | MASTER PACK | SHELF PACK |
|----------|-------------------------------------------|----------------|---------------|-------------|------------|
| TMFC153 | Unbreakable S.G. Iron Flooring Clamp 75mm | 3" / 75mm | 0734442034926 | 6 | 1 |

G-CLAMPS

IRWIN® Record® G-Clamps have an I-Braced design. They feature an adjustable steel swivel shoe to help clamp uneven surfaces and operation is fast and smooth due to the twin-start Acme cold rolled thread.

HEAVY-DUTY G-CLAMPS 121 SERIES - THE STRONGEST G-CLAMP

SWIVEL SHOE

TWIN-START ACME COLD ROLLED THREAD

FUSED STEEL HANDLE

DROP-FORGED STEEL FRAME

HEAVY-DUTY G-CLAMPS 121 SERIES

IRWIN® Record® Heavy-Duty G-Clamps are recommended particularly for metalworking and fabrication work where a very high clamping force is demanded.

- 1. DROP-FORGED STEEL FRAME**
For strength and durability. Recommended for heavy-duty metal and fabrication work
- 2. SWIVEL SHOE**
Helps clamping on uneven surfaces
- 3. TWIN-START ACME COLD ROLLED THREAD**
For faster and smoother operation
- 4. FUSED STEEL HANDLE**
Will bend before the clamp can be overstressed

| ITEM NO. | DESCRIPTION | CLAMP CAPACITY | PROOF LOAD | EAN | MASTER PACK | SHELF PACK |
|----------|---------------------|----------------|------------|---------------|-------------|------------|
| T1213 | Heavy-Duty G-Clamp | 3" / 75mm | 2700 kg | 0734442031802 | 24 | 4 |
| T1214 | Heavy-Duty G-Clamp | 4" / 100mm | 3200 kg | 0734442031925 | 24 | 4 |
| T1216 | Heavy-Duty G-Clamp | 6" / 150mm | 4000 kg | 0734442032045 | 12 | 1 |
| T1218 | Heavy-Duty G-Clamp | 8" / 200mm | 5770 kg | 0734442032168 | 12 | 1 |
| T12110 | Heavy-Duty G-Clamp | 10" / 250mm | 6200 kg | 0734442032281 | 6 | 1 |
| T12112 | Heavy-Duty G-Clamp | 12" / 300mm | 6800 kg | 0734442032403 | 6 | 1 |
| T1224 | Deep Throat G-Clamp | 4" / 100mm | - | 0734442030843 | 40 | 4 |



T1218

MEDIUM-DUTY G-CLAMPS 119 SERIES

IRWIN® Record® medium-duty clamps have a thin frame for getting into tight corners and confined spaces, yet are very strong and rigid.

| ITEM NO. | DESCRIPTION | CLAMP CAPACITY | EAN | MASTER PACK | SHELF PACK |
|----------|---------------------|----------------|---------------|-------------|------------|
| T1192 | Medium-Duty G-Clamp | 2" / 50mm | 0734442030485 | - | 6 |
| T1193 | Medium-Duty G-Clamp | 3" / 75mm | 0734442030720 | - | 6 |
| T1194 | Medium-Duty G-Clamp | 4" / 100mm | 0734442000600 | - | 6 |
| T1196 | Medium-Duty G-Clamp | 6" / 150mm | 0734442041337 | - | 6 |



T1193

GENERAL PURPOSE G-CLAMPS 120 SERIES

Ideal for metal and woodworking applications, the IRWIN® Record® 120 is the most popular and widely used of G-Clamps.

| ITEM NO. | DESCRIPTION | CLAMP CAPACITY | EAN | MASTER PACK | SHELF PACK |
|----------|-------------------------|----------------|---------------|-------------|------------|
| T1203 | General Purpose G-Clamp | 3" / 75mm | 0734442031086 | 72 | 4 |
| T1204 | General Purpose G-Clamp | 4" / 100mm | 0734442031208 | 72 | 4 |
| T1206 | General Purpose G-Clamp | 6" / 150mm | 0734442031321 | 60 | 4 |
| T1208 | General Purpose G-Clamp | 8" / 200mm | 0734442031444 | 24 | 1 |
| T12010 | General Purpose G-Clamp | 10" / 250mm | 0734442031567 | 24 | 1 |
| T12012 | General Purpose G-Clamp | 12" / 300mm | 0734442031680 | 24 | 1 |



T1204



IRWIN®

Record®



VICES AND ACCESSORIES

IRWIN® Record® Vices have become the benchmark by which all other vices are measured. Design, choice of materials and manufacturing disciplines each set very high standards which, for the end user, translate into safety, reliability and excellent value.

ENGINEERS' VICE - LIFETIME VICE RANGE

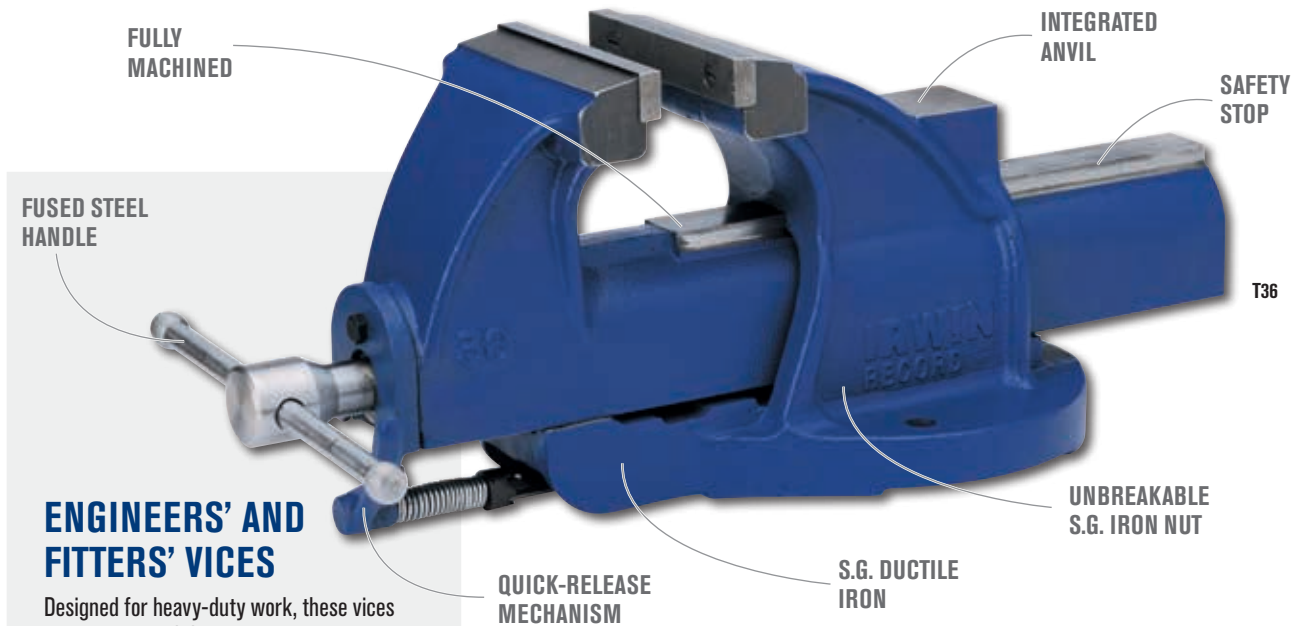

ENGINEERS' AND FITTERS' VICES

Designed for heavy-duty work, these vices are made from S.G. Ductile Iron with an integrated anvil for shaping and beating, together with a quick-release mechanism for rapid slide adjustment. The reinforced body, slide and large diameter main screw contribute to the working strength and resilience, and the vices withstand the most demanding work. Fitters' vices are similar in design to Engineers' however are made of close grained gray iron instead of S.G. Ductile Iron. They also have a full line of replacement parts available.

1. **S.G. DUCTILE IRON**
Material with high-impact resistance guarantees strength and long life (Engineers' vices only)
2. **SAFETY STOP**
Prevents the slide from being separated from the body
3. **FULLY MACHINED**
On all load-bearing surfaces for smooth and trouble-free operation
4. **FUSED STEEL HANDLE**
Will bend before the vice can be overstressed
5. **QUICK-RELEASE MECHANISM**
Disengages the main screw, allowing rapid movement of the slide
6. **UNBREAKABLE S.G. IRON NUT**
Can be replaced when worn
7. **INTEGRATED ANVIL**
For efficient striking of workpieces when required

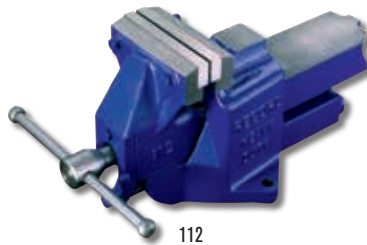
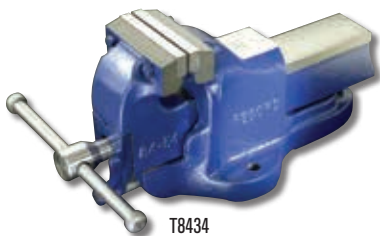

| ITEM NO. | DESCRIPTION | EAN | MASTER PACK | SHELF PACK |
|----------|-----------------------------------------------|---------------|-------------|------------|
| T8434 | Engineers Vice 4-1/2" / 115mm** | 0734442019442 | 42 | 1 |
| T36 | Engineers Vice 6" / 150mm** (Irregular Shape) | 0734442019206 | 18 | 1 |
| 112 | Engineers Vice 6" / 150mm** | 0734442019565 | 22 | 1 |
| 114ZR | Engineers Vice 8" / 205mm** | 0734442019688 | 22 | 1 |
| 23ZR | Fitters Vice 4-1/2" / 115mm | 0734442001089 | 28 | 1 |
| T25 | Fitters Vice 6" / 150mm | 0734442001201 | 22 | 1 |

SPARE PARTS ALSO AVAILABLE
SEE PAGE 62

**S.G. Ductile Iron is strong and flexible with similar characteristics to steel and is virtually unbreakable. Heavy duty vices manufactured from this material are designed to take much more punishing workloads than normal vices.



QUICK-ADJUSTING VICE GENERAL PURPOSE / MEDIUM-DUTY



NEW

IRWIN® RECORD® QUICK-ADJUSTING VICE

The NEW Quick-Adjusting Vice features a fast release lever to quickly loosen the jaws of the vice and return it to the locked position, greatly reducing the time necessary to adjust the vice. This vice with integrated anvil is designed for general purpose clamping and medium-duty applications and for applications requiring frequent clamping and changing of multiple materials.



- 1. QUICK-RELEASE FUNCTIONALITY**
Fast-release lever for quick adjustments to increase productivity
- 2. S.G. DUCTILE IRON BODY**
Guaranteeing strength and long life
- 3. SWIVEL BASE**
Three mounting points and a 120° rotation for more flexible positioning of workpieces
- 4. FUSED STEEL HANDLE**
Will bend before the vice can be overstressed
- 5. INTEGRATED ANVIL**
For hammering and beating workpieces
- 6. SAFETY STOP**
Prevents slide separating from body



1978272

| ITEM NO. | DESCRIPTION | EAN | MASTER PACK | SHELF PACK |
|----------|---------------------------------|---------------|-------------|------------|
| 1978271 | Quick-Adjusting Vice 4" / 100mm | 5706919782710 | 1 | 1 |
| 1978272 | Quick-Adjusting Vice 5" / 125mm | 5706919782727 | 1 | 1 |

MECHANICS' VICE - HEAVY-DUTY RANGE

IRWIN® RECORD® MECHANICS' VICE

Rigid and robust, the body and sliding jaw are cast from close grained grey iron which is machined on all friction surfaces for a smooth, reliable action.

The jaws, handle and main screw are steel, the latter having a two-start rolled acme thread to speed the jaws from fully closed to fully open with a minimum of winding. The Mechanics' vice is the most commonly used vice in the IRWIN® Record® range. A full line of replacement parts are available.

- 1. CLOSE GRAINED GREY IRON BODY & SLIDING JAW**
Cast then machined on all friction surfaces for a smooth, reliable action
- 2. SAFETY STOP**
Prevents the slide from being separated from the body
- 3. HARDENED STEEL JAWS**
Extend the life of the jaws and are replaceable
- 4. UNBREAKABLE S.G. IRON NUT**
Can be replaced when worn
- 5. FUSED STEEL HANDLE**
Will bend before the vice can be overstressed
- 6. TWIN-START ACME COLD ROLLED THREAD**
For faster and smoother operation

| ITEM NO. | DESCRIPTION | EAN | MASTER PACK | SHELF PACK |
|----------|--------------------------------------|---------------|-------------|------------|
| 1ZR | No 1, Mechanics' Vice 3" / 75mm | 0734442000129 | 144 | 1 |
| 3 | No 3, Mechanics' Vice 4" / 100mm | 0734442000488 | 60 | 1 |
| 4ZR | No 4, Mechanics' Vice 4-1/2" / 115mm | 0734442000501 | 40 | 1 |
| 5 | No 5, Mechanics' Vice 5" / 125mm | 0734442000723 | 40 | 1 |
| 6 | No 6, Mechanics' Vice 6" / 150mm | 0734442000846 | 32 | 1 |
| 8ZR | No 8, Mechanics' Vice 8" / 205mm | 0734442000969 | 24 | 1 |



WORKSHOP VICE - MEDIUM DUTY

Strong and durable, the body and sliding jaw are cast from close-grained grey iron which is machined on all friction surfaces for a smooth reliable action. The jaws, handle and main screw are steel, the latter having a two-start rolled acme thread to speed the jaws from fully closed to fully open with a minimum of winding. This compact bench vice with anvil is specifically designed for medium-duty workshop applications for both the professional craftsman and the DIY enthusiast who expect a compact vice with superior clamping force, safety features and excellent finish.

| ITEM NO. | DESCRIPTION | EAN | MASTER PACK | SHELF PACK |
|-----------|----------------------------------------------------------|---------------|-------------|------------|
| 10507771 | Workshop Vice with Anvil, 3-1/8" / 80mm | 5706915077711 | 1 | 1 |
| T41211000 | Workshop Vice with Anvil, 1 TON, 4" / 100mm | 0734442000204 | 105 | 1 |
| T3TON3VS | Workshop Vice with Anvil, Swivel Base, 4" / 100mm | 0734442000310 | 60 | 1 |
| 4935505 | Workshop Multi-Vice, with Anvil, Swivel Base, 5" / 125mm | 0038548989990 | 40 | 1 |
| T6TON6VS | Workshop Vice with Anvil, Swivel Base, 6" / 150mm | 0734442000860 | 40 | 1 |
| 8ZR | No 8, Mechanics' Vice 8" / 205mm | 0734442000969 | 24 | 1 |



PROFESSIONAL QUICK-RELEASE WOODWORKING VICE

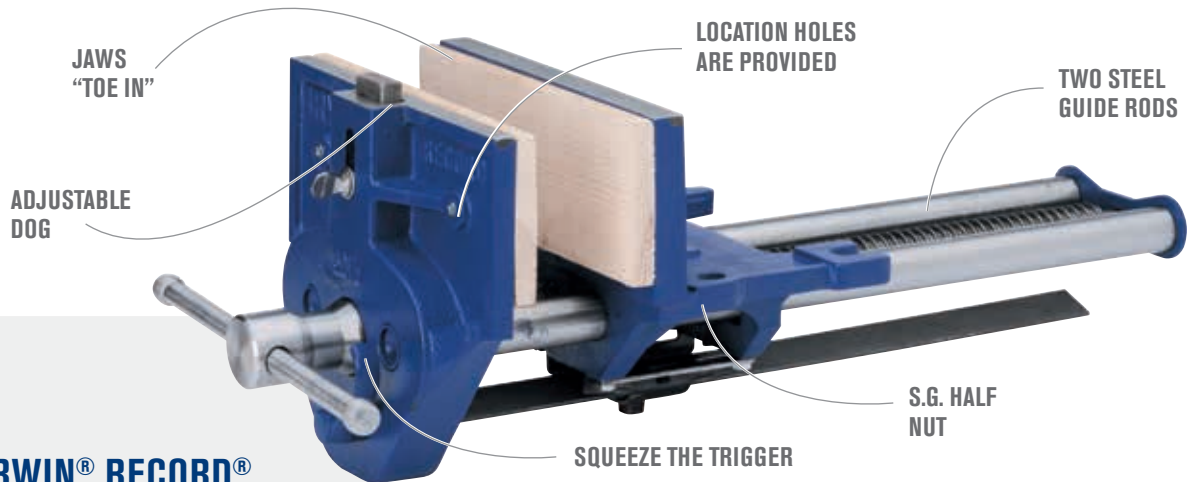

IRWIN® RECORD® QUICK-RELEASE VICE

Squeeze the trigger and a quick-release vice can be opened and closed without using the mainscrew. Large and small work pieces can be quickly interchanged, while releasing the trigger returns the mechanism to normal for fine adjustment. An ideal addition to the engineering workshop or tool room. For clamping and holding wood work pieces.

- TWO STEEL GUIDE RODS**
To reduce wear and ensure a smooth parallel action
- JAWS "TOE IN"**
When pressure is applied they give an even clamping over the whole depth of the work-piece
- ADJUSTABLE DOG**
Used in conjunction with bench stops fitted into the bench top
- LOCATION HOLES ARE PROVIDED**
So you can fit your own choice of wooden cheeks to protect the work-piece
- SQUEEZE THE TRIGGER**
A quick release vice can be opened and closed without using the mainscrew. Large and small work-pieces can be quickly interchanged
- S.G. HALF NUT**
For longevity and durability replaceable when worn

| | ITEM NO. | DESCRIPTION | EAN | MASTER PACK | SHELF PACK |
|---------|----------|------------------------------------------------|---------------|-------------|------------|
| T5212ED | T52ED | Woodworking Vice - Quick-Release 7"/175mm | 0734442030249 | 60 | 1 |
| | T5212ED | Woodworking Vice - Quick-Release 9"/230mm | 0734442030362 | 32 | 1 |
| | T53ED | Woodworking Vice - Quick-Release 10-1/2"/265mm | 0734442030010 | 24 | 1 |

PLAIN SCREW VICE

Manufactured in three capacities, these full size workshop vices are designed for bench mounting. The cast grey iron body and front plate are precision machined to house two solid steel guide rods giving the vice a smooth, true parallel action free of side or cross movement.

| | ITEM NO. | DESCRIPTION | EAN | MASTER PACK | SHELF PACK |
|-------|----------|----------------------------------------------|---------------|-------------|------------|
| T53PD | T52PD | Woodworking Vice - Plain Screw 7"/175mm | 0734442047889 | 60 | 1 |
| | T5212PD | Woodworking Vice - Plain Screw 9"/230mm | 0734442029796 | 32 | 1 |
| | T53PD | Woodworking Vice - Plain Screw 10-1/2"/265mm | 0734442030133 | 24 | 1 |

WOODCRAFT VICE

Lightweight vice for the young woodworker, or home handyman. Provides a robust product suitable for the professional who needs a compact vice for smaller work. Designed to be fitted under the work bench, in the normal way, so that the jaws are flush with the bench top. TV150B includes table clamp.

| | ITEM NO. | DESCRIPTION | EAN | MASTER PACK | SHELF PACK |
|--------|----------|------------------------------------------|---------------|-------------|------------|
| TV150B | TV149B | Woodcraft Vice 6"/150mm | 0734442029656 | - | 1 |
| | TV150B | Woodcraft Vice with Table Clamp 6"/150mm | 0734442029779 | - | 1 |
| | TV175B | Woodcraft Vice 7"/175mm | 0734442029885 | - | 1 |

TABLE VICE

This is an ideal portable vice for the amateur and model maker. The built-in clamp allows it to be easily and quickly attached to a bench, table or work surface. Pipe grips are incorporated below the parallel jaws. A useful anvil is also included on the rear of the body.

| ITEM NO. | DESCRIPTION | EAN | MASTER PACK | SHELF PACK |
|----------|----------------------|---------------|-------------|------------|
| TV75B | Table Vice 3" / 75mm | 0734442001690 | - | 1 |



TV75B

DRILL PRESS VICE

Quality and precision are the hallmarks of the IRWIN® Record® Drill Press Vice, an ideal addition to the engineering workshop or tool room. Designed for use with drill presses and pillar drills.

| ITEM NO. | DESCRIPTION | EAN | MASTER PACK | SHELF PACK |
|----------|-----------------------------|---------------|-------------|------------|
| T414 | Drill Press Vice 4" / 100mm | 0734442001560 | - | 1 |



T414

SWIVEL BASES

360 degree swivel bases are used to rotate and lock the vice at the most convenient angle.

| ITEM NO. | DESCRIPTION | EAN | MASTER PACK | SHELF PACK |
|-----------|----------------------------------------|---------------|-------------|------------|
| T1SB | Swivel Base, (No. 1 Vice) | 0734442002888 | - | 1 |
| T3SB | Swivel Base, (No. 3 Vice) | 0734442003007 | - | 1 |
| T4SB | Swivel Base, (No. 4 & 5 Vice) | 0734442003120 | - | 1 |
| T6SB | Swivel Base, (No. 6, 8, 25 & 36 Vices) | 0734442003366 | - | 1 |
| T843423SB | Swivel Base, (No. T8434 & 23ZR Vices) | 0734442019459 | - | 1 |
| 10507772 | Swivel Base, (No. 10507771) | 5706915077728 | - | 1 |



T1SB

FIBRE GRIPS

Designed for holding & protecting workpieces of copper, aluminium, brass and similar soft metals.

| ITEM NO. | DESCRIPTION | EAN | MASTER PACK | SHELF PACK |
|----------|----------------------------|---------------|-------------|------------|
| FG3 | Fibre Grips 3" / 75mm | 0734442001928 | 60 | 6 |
| FG4 | Fibre Grips 4" / 100mm | 0734442002161 | 60 | 6 |
| FG412 | Fibre Grips 4-1/2" / 115mm | 0734442002406 | 60 | 6 |
| FG5 | Fibre Grips 5" / 125mm | 0734442002529 | 60 | 6 |
| FG6 | Fibre Grips 6" / 150mm | 0734442002765 | 60 | 6 |



FG3

FG5

CHAIN PIPE VICES

The chain pipe vice generates a powerful grip due to its sturdy construction. The drop-forged, heat-treated steel jaws and high-tensile steel chain are mounted on a body cast from ductile iron that is guaranteed unbreakable. The flexible chain means the vice is compact and easy to store when not in use.

| ITEM NO. | DESCRIPTION | EAN | MASTER PACK | SHELF PACK |
|----------|----------------------------------------|---------------|-------------|------------|
| T181C | Chain Pipe Vice 1/8" - 2" / 3 - 50mm | 0734442143161 | - | 1 |
| T182C | Chain Pipe Vice 1/4" - 4" / 6 - 100mm | 0734442143284 | - | 1 |
| T183C | Chain Pipe Vice 1/2" - 8" / 12 - 200mm | 0734442143406 | - | 1 |



T182C

HINGED PIPE VICES

The hinged pipe vice frame and base are cast from high-impact resistant S.G. ductile iron guaranteeing strength. The design is ideal for fast, repetitive work.

| ITEM NO. | DESCRIPTION | EAN | MASTER PACK | SHELF PACK |
|----------|-------------------------------------------|---------------|-------------|------------|
| T92C | Hinged Pipe Vice 1/8" - 2" / 3 - 50mm | 0734442143529 | - | 1 |
| T9212C | Hinged Pipe Vice 1/8" - 2-1/2" / 3 - 60mm | 0734442143642 | - | 1 |
| T9312C | Hinged Pipe Vice 1/8" - 3-1/2" / 3 - 90mm | 0734442143765 | - | 1 |
| T96 | Hinged Pipe Vice 1/8" - 6" / 3 - 150mm | 0734442143888 | - | 1 |



T9312C

TRIPOD STAND

The durable fabricated steel frame, topped by a strong heavy-gauge mounting plate, is drilled to accept our range of chain and hinged pipe vices.

| ITEM NO. | DESCRIPTION | EAN | MASTER PACK | SHELF PACK |
|----------|---------------------------------------------------------------------------|---------------|-------------|------------|
| TS10 | Tripod Stand for Hinged Pipe Vice & Chain Pipe Vice (T182C, T92C, T9212C) | 0734442142560 | - | 1 |



WORKHOLDING - SPARE PARTS

T23 - T25 FITTERS' / T36 - T8434 ENGINEERS' / T112 - T114 HD VICES

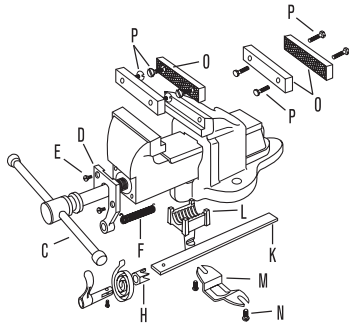

| ITEM NO. | DESCRIPTION | EAN | MASTER PACK | SHELF PACK |
|----------|-----------------------------------------------------------------|---------------|-------------|------------|
| T23C | Mainscrew with Handle (C), Nut (L), Nut Guide (M), & Screws (N) | 0734442010920 | - | 1 |
| T25C | Mainscrew with Handle (C), Nut (L), Nut Guide (M), & Screws (N) | 0734442012603 | - | 1 |
| T112C | Mainscrew with Handle (C), Nut (L), Nut Guide (M), & Screws (N) | 0734442025207 | - | 1 |
| T114C | Mainscrew with Handle (C), Nut (L), Nut Guide (M), & Screws (N) | 0734442025924 | - | 1 |
| T36C | Mainscrew with Handle (C), Nut (L), Nut Guide (M), & Screws (N) | 0734442021841 | - | 1 |
| 84C | Mainscrew with Handle (C), Nut (L), Nut Guide (M), & Screws (N) | 0734442023647 | - | 1 |
| T23DK | Trigger Complete | 0734442011408 | - | 1 |
| T25DK | Trigger Complete | 0734442012962 | - | 1 |
| T112DK | Trigger Complete | 0734442025801 | - | 1 |
| T114DK | Trigger Complete | 0734442026402 | - | 1 |
| T36DK | Trigger Complete | 0734442022329 | - | 1 |
| T84DK | Trigger Complete | 0734442024002 | - | 1 |
| T23L | Half Nut (L), Guide (M) & Screws (N) | 0734442011163 | - | 1 |
| T25L | Half Nut (L), Guide (M) & Screws (N) | 0734442012849 | - | 1 |
| T112L | Half Nut (L), Guide (M) & Screws (N) | 0734442025443 | - | 1 |
| T114L | Half Nut (L), Guide (M) & Screws (N) | 0734442026167 | - | 1 |
| T36L | Half Nut (L), Guide (M) & Screws (N) | 0734442022084 | - | 1 |
| T84L | Half Nut (L), Guide (M) & Screws (N) | 0734442022688 | - | 1 |
| T230 | Jaw Plates (pair) with Screws (P) | 0734442011286 | - | 1 |
| T250 | Jaw Plates (pair) with Screws (P) | 0734442011521 | - | 1 |
| T1120 | Jaw Plates (pair) with Screws (P) | 0734442025566 | - | 1 |
| T1140 | Jaw Plates (pair) with Screws (P) | 0734442026280 | - | 1 |
| T360 | Jaw Plates (pair) with Screws (P) | 0734442022206 | - | 1 |
| T840 | Jaw Plates (pair) with Screws (P) | 0734442023883 | - | 1 |

SPARE PARTS FOR NO.1 - NO. 8 MECHANICS' VICES

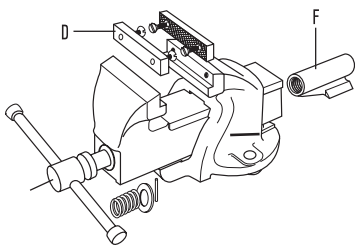

| ITEM NO. | DESCRIPTION | EAN | MASTER PACK | SHELF PACK |
|----------|----------------------------------------------------------------|---------------|-------------|------------|
| T1C | Mainscrew with Handle, Nut, Pin, Spring Washer & Pin (C) & (F) | 0734442004561 | - | 1 |
| T3C | Mainscrew with Handle, Nut, Pin, Spring Washer & Pin (C) & (F) | 0734442006121 | - | 1 |
| T4C | Mainscrew with Handle, Nut, Pin, Spring Washer & Pin (C) & (F) | 0734442006961 | - | 1 |
| T5C | Mainscrew with Handle, Nut, Pin, Spring Washer & Pin (C) & (F) | 0734442007807 | - | 1 |
| T6C | Mainscrew with Handle, Nut, Pin, Spring Washer & Pin (C) & (F) | 0734442008521 | - | 1 |
| T8C | Mainscrew with Handle, Nut, Pin, Spring Washer & Pin (C) & (F) | 0734442009009 | - | 1 |
| T1D | Pair of Jaw Plates with Screws | 0734442004684 | - | 1 |
| T3D | Pair of Jaw Plates with Screws | 0734442006244 | - | 1 |
| T4D | Pair of Jaw Plates with Screws | 0734442007081 | - | 1 |
| T5D | Pair of Jaw Plates with Screws | 0734442007920 | - | 1 |
| T6D | Pair of Jaw Plates with Screws | 0734442008644 | - | 1 |
| T8D | Pair of Jaw Plates with Screws | 0734442009481 | - | 1 |

SPARE PARTS FOR T400300 PIPE VICE

| ITEM NO. | DESCRIPTION | EAN | MASTER PACK | SHELF PACK |
|----------|-----------------------------------------|---------------|-------------|------------|
| T661053 | 50mm Hinged Pipe Vice for Stand Benders | 0686182000788 | - | 1 |

SPARE PARTS FOR T52 - T53 QUICK-RELEASE VICES

| ITEM NO. | DESCRIPTION | EAN | MASTER PACK | SHELF PACK |
|-----------|---------------------------------------------------------|---------------|-------------|------------|
| T52EDA | Sliding Jaw (A) | 0734442037323 | - | 1 |
| T5212EDA | Sliding Jaw (A) | 0734442038528 | - | 1 |
| T53EDA | Sliding Jaw (A) | 0734442009955 | - | 1 |
| T52EDC | Main Screw with Handle & Washers (E), Pin (F), Nut (O) | 0734442037569 | - | 1 |
| T5212EDC | Main Screw with Handle & Washers (E), Pin (F), Nut (O) | 0734442038764 | - | 1 |
| T53EDC | Main Screw with Handle & Washers (E), Pin (F), Nut (O) | 0734442009962 | - | 1 |
| T52EDD | End Bracket with End Washers & Pin (F) | 0734442037682 | - | 1 |
| T5212EDD | End Bracket with End Washers & Pin (F), also fits T53ED | 0734442038887 | - | 1 |
| T52EDJN | Trigger Complete | 0734442038405 | - | 1 |
| T5212EDJN | Trigger Complete (also fits T53ED) | 0734442039488 | - | 1 |
| T52EDL | Trigger Spring & Nut (fits all sizes) | 0734442038047 | - | 1 |
| T52EDO | Nut with Nut Guide & Screws | 0734442038160 | - | 1 |
| T5212EDO | Nut with Nut Guide & Screws (also fits T53ED) | 0734442039242 | - | 1 |
| T52EDT | Front Dog with Screws & Washers (fits all sizes) | 0734442040927 | - | 1 |

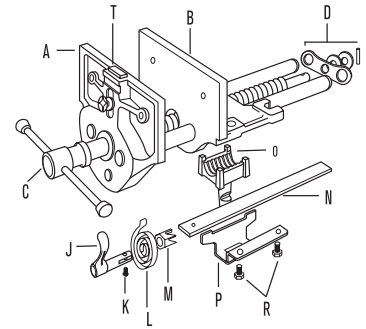

SPARE PARTS FOR T52 - T53 PLAIN SCREW VICES

| ITEM NO. | DESCRIPTION | EAN | MASTER PACK | SHELF PACK |
|----------|-------------------------------------------|---------------|-------------|------------|
| T52PDC | Mainscrew with Handle & Pin (F) & Nut (O) | 0734442047902 | - | 1 |
| T5212PDC | Mainscrew with Handle & Pin (F) & Nut (O) | 0734442009924 | - | 1 |
| T53PDC | Mainscrew with Handle & Pin (F) & Nut (O) | 0734442009979 | - | 1 |
| T5212PDO | Nut (also fits T53PD) | 0734442009931 | - | 1 |

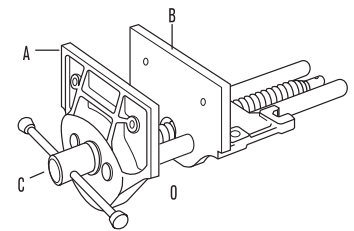

SPARE PARTS FOR T92C - T93-1/2C & T96 HINGED PIPE VICES

| ITEM NO. | DESCRIPTION | EAN | MASTER PACK | SHELF PACK |
|----------|-------------------------------------|---------------|-------------|------------|
| T92CC | Main Screw with Handle | 0734442160564 | - | 1 |
| T9212CC | Main Screw with Handle | 0734442163442 | - | 1 |
| T92CD | Locking Hook & Rivet (H) | 0734442160687 | - | 1 |
| T9212CD | Locking Hook & Rivet (H) | 0734442163565 | - | 1 |
| T92CE | Jaw Clamp (Per Pair) | 0734442160809 | - | 1 |
| T9312CE | Jaw Clamp (Per Pair) | 0734442166320 | - | 1 |
| T92CF | Lower Jaws (Pair) with Bolts & Nuts | 0734442160922 | - | 1 |
| T9312CF | Lower Jaws (Pair) with Bolts & Nuts | 0734442165484 | - | 1 |
| T96F | Lower Jaws (Pair) with Bolts & Nuts | 0734442168720 | - | 1 |
| T92CG | Upper Jaws with Bolts & Nuts | 0734442162247 | - | 1 |
| T9312CG | Upper Jaws with Bolts & Nuts | 0734442165606 | - | 1 |
| T96G | Upper Jaws with Bolts & Nuts | 0734442168843 | - | 1 |

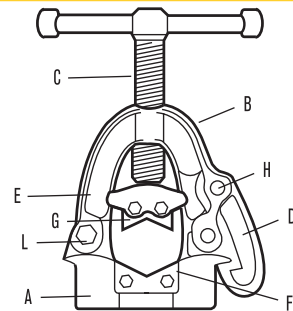

SPARE PARTS FOR T181C, T182C, T183C CHAIN PATTERN VICES

| ITEM NO. | DESCRIPTION | EAN | MASTER PACK | SHELF PACK |
|----------|--------------------|---------------|-------------|------------|
| T183CA | Base | 0734442157328 | - | 1 |
| T182CB | Jaw Unit with Bolt | 0734442156963 | - | 1 |
| T183CB | Jaw Unit with Bolt | 0734442157441 | - | 1 |
| T182CC | Chain with Screw | 0734442157083 | - | 1 |
| T183CC | Chain with Screw | 0734442159124 | - | 1 |
| T183CD | Handle with Nut | 0734442157564 | - | 1 |

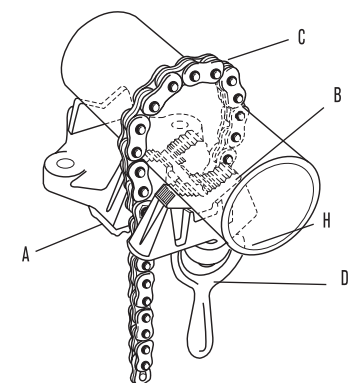

IRWIN[®]



SCREWDRIVERS & HEX KEYS

PRO COMFORT & VDE INSULATED SCREWDRIVERS

The new IRWIN® Pro Comfort Screwdrivers have been designed for comfort, durability and safety. The screwdrivers feature a dual material, trilobular handle for an ergonomic grip, black phosphate magnetic tip and are made with Chrome-vanadium (Cr-V) steel shafts with corrosion protection. The VDE range of screwdrivers are insulated for electrical work up to 1000V AC.

PRO COMFORT SCREWDRIVERS

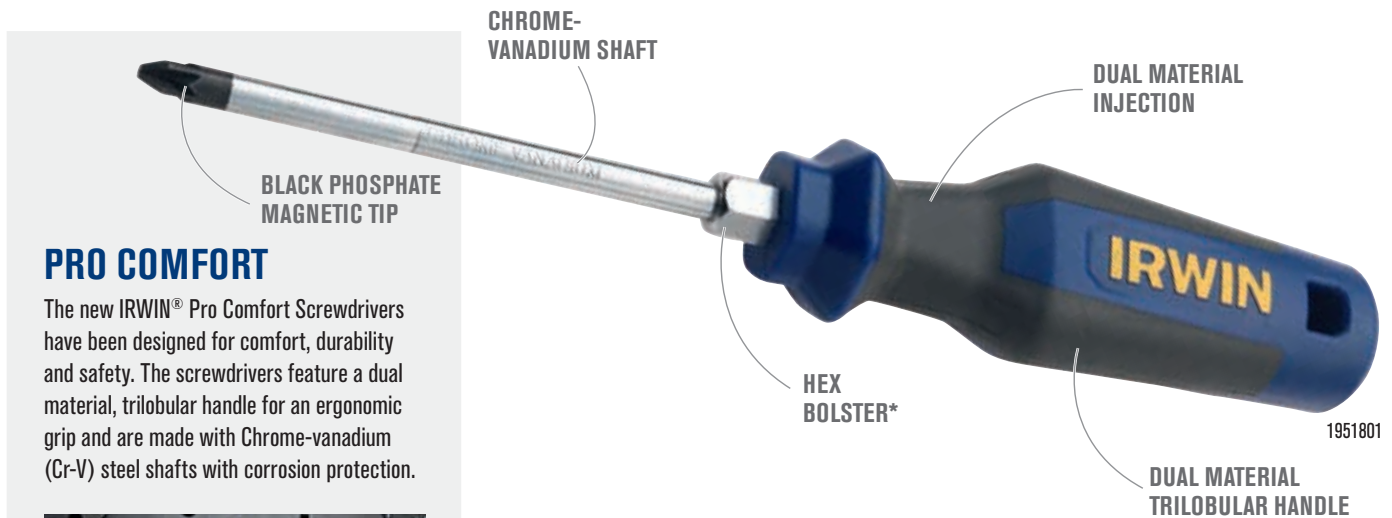

PRO COMFORT

The new IRWIN® Pro Comfort Screwdrivers have been designed for comfort, durability and safety. The screwdrivers feature a dual material, trilobular handle for an ergonomic grip and are made with Chrome-vanadium (Cr-V) steel shafts with corrosion protection.



- 1. DUAL MATERIAL TRILOBULAR HANDLE**
Provides an ergonomic grip
- 2. BLACK PHOSPHATE MAGNETIC TIP**
For improved screw alignment, easy driving and extended life of tip
- 3. DUAL MATERIAL INJECTION**
Delivers greater comfort in use
- 4. CHROME-VANADIUM SHAFT**
Includes corrosion protection for longer life of the tool
- 5. HEX BOLSTER***
Allows for increased torque with use of wrench

* Select skus only

POZIDRIV

| ITEM NO. | DESCRIPTION | EAN | MASTER PACK | SHELF PACK |
|----------|--------------------------------------------------------|---------------|-------------|------------|
| 1951676 | Pro Comfort Screwdriver PZ #0 x 80mm | 5706919516766 | 120 | 6 |
| 1951677 | Pro Comfort Screwdriver PZ #1 x 30mm | 5706919516773 | 120 | 6 |
| 1951678 | Pro Comfort Screwdriver PZ #1 x 100mm | 5706919516780 | 72 | 6 |
| 1951679 | Pro Comfort Screwdriver PZ #1 x 250mm | 5706919516797 | 72 | 6 |
| 1951680 | Pro Comfort Screwdriver PZ #2 x 30mm | 5706919516803 | 120 | 6 |
| 1951801 | Pro Comfort Screwdriver PZ #2 x 100mm with Hex Bolster | 5706919518012 | 72 | 6 |
| 1951802 | Pro Comfort Screwdriver PZ #2 x 125mm with Hex Bolster | 5706919518029 | 72 | 6 |
| 1951803 | Pro Comfort Screwdriver PZ #2 x 250mm with Hex Bolster | 5706919518036 | 48 | 6 |



PHILLIPS

| ITEM NO. | DESCRIPTION | EAN | MASTER PACK | SHELF PACK |
|----------|--------------------------------------------------------|---------------|-------------|------------|
| 1951814 | Pro Comfort Screwdriver PH #0 x 80mm | 5706919518142 | 120 | 6 |
| 1951807 | Pro Comfort Screwdriver PH #1 x 100mm | 5706919518074 | 72 | 6 |
| 1951808 | Pro Comfort Screwdriver PH #1 x 250mm | 5706919518081 | 72 | 6 |
| 1951810 | Pro Comfort Screwdriver PH #2 x 38mm | 5706919518104 | 120 | 6 |
| 1951811 | Pro Comfort Screwdriver PH #2 x 100mm with Hex Bolster | 5706919518111 | 72 | 6 |
| 1951812 | Pro Comfort Screwdriver PH #2 x 125mm with Hex Bolster | 5706919518128 | 72 | 6 |
| 1951813 | Pro Comfort Screwdriver PH #2 x 250mm with Hex Bolster | 5706919518135 | 48 | 6 |
| 1951816 | Pro Comfort Screwdriver PH #3 x 150mm with Hex Bolster | 5706919518166 | 48 | 6 |

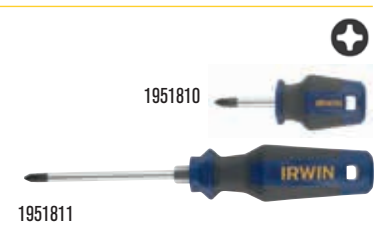

SLOTTED



1951821

| ITEM NO. | DESCRIPTION | EAN | MASTER PACK | SHELF PACK |
|----------|-----------------------------------------------------------|---------------|-------------|------------|
| 1951818 | Pro Comfort Screwdriver SL 3 mm x 80mm | 5706919518180 | 120 | 6 |
| 1951819 | Pro Comfort Screwdriver SL 3mm x 100mm | 5706919518197 | 120 | 6 |
| 1951820 | Pro Comfort Screwdriver SL 5mm x 100mm | 5706919518203 | 72 | 6 |
| 1951821 | Pro Comfort Screwdriver SL 5.5mm x 100mm | 5706919518210 | 72 | 6 |
| 1951824 | Pro Comfort Screwdriver SL 6.5mm x 150mm with Hex Bolster | 5706919518241 | 72 | 6 |
| 1951825 | Pro Comfort Screwdriver SL 8mm x 150mm with Hex Bolster | 5706919518258 | 48 | 6 |
| 1951826 | Pro Comfort Screwdriver SL 8mm x 175mm with Hex Bolster | 5706919518265 | 48 | 6 |
| 1951827 | Pro Comfort Screwdriver SL 8mm x 200mm with Hex Bolster | 5706919518272 | 48 | 6 |
| 1951828 | Pro Comfort Screwdriver SL 9mm x 200mm with Hex Bolster | 5706919518289 | 48 | 6 |

PARALLEL



1951848

| ITEM NO. | DESCRIPTION | EAN | MASTER PACK | SHELF PACK |
|----------|--------------------------------------------|---------------|-------------|------------|
| 1951842 | Pro Comfort Screwdriver PARA 3mm x 100mm | 5706919518425 | 120 | 6 |
| 1951843 | Pro Comfort Screwdriver PARA 3 mm x 150mm | 5706919518432 | 120 | 6 |
| 1951844 | Pro Comfort Screwdriver PARA 3.5mm x 80mm | 5706919518449 | 120 | 6 |
| 1951845 | Pro Comfort Screwdriver PARA 4mm x 100mm | 5706919518456 | 120 | 6 |
| 1951846 | Pro Comfort Screwdriver PARA 4mm x 150mm | 5706919518463 | 120 | 6 |
| 1951848 | Pro Comfort Screwdriver PARA 5.5mm x 100mm | 5706919518487 | 72 | 6 |
| 1951849 | Pro Comfort Screwdriver PARA 5.5mm x 150mm | 5706919518494 | 72 | 6 |
| 1951850 | Pro Comfort Screwdriver PARA 6.5mm x 30mm | 5706919518500 | 120 | 6 |

TORX



1951857

| ITEM NO. | DESCRIPTION | EAN | MASTER PACK | SHELF PACK |
|----------|--------------------------------------|---------------|-------------|------------|
| 1951855 | Pro Comfort Screwdrivers T10 x 100mm | 5706919518555 | 72 | 6 |
| 1951856 | Pro Comfort Screwdrivers T15 x 100mm | 5706919518562 | 72 | 6 |
| 1951857 | Pro Comfort Screwdrivers T20 x 100mm | 5706919518579 | 72 | 6 |
| 1951858 | Pro Comfort Screwdrivers T25 x 125mm | 5706919518586 | 72 | 6 |
| 1951859 | Pro Comfort Screwdrivers T27 x 125mm | 5706919518593 | 72 | 6 |
| 1951860 | Pro Comfort Screwdrivers T30 x 125mm | 5706919518609 | 72 | 6 |
| 1951861 | Pro Comfort Screwdrivers T40 x 150mm | 5706919518616 | 48 | 6 |

VDE INSULATED SCREWDRIVERS

VDE INSULATION

BLACK PHOSPHATE MAGNETIC TIP

CHROME-VANADIUM SHAFT

DUAL MATERIAL INJECTION

DUAL MATERIAL TRILOBULAR HANDLE

IRWIN

1951864

VDE INSULATED

- 1. VDE INSULATION**
Insulated for electrical work up to 1000V AC
- 2. DUAL MATERIAL TRILOBULAR HANDLE**
Provides an ergonomic grip
- 3. BLACK PHOSPHATE MAGNETIC TIP**
For improved screw alignment, easy driving and extended life of tip
- 4. DUAL MATERIAL INJECTION**
Delivers greater comfort in use
- 5. CHROME-VANADIUM SHAFT**
Includes corrosion protection for longer life of the tool

POZIDRIV

| ITEM NO. | DESCRIPTION | EAN | MASTER PACK | SHELF PACK |
|----------|-----------------------------------------------------|---------------|-------------|------------|
| 1951867 | Pro Comfort VDE Insulated Screwdriver PZ #0 x 80 mm | 5706919518678 | 120 | 6 |
| 1951866 | Pro Comfort VDE Insulated Screwdriver PZ #1 x 100mm | 5706919518661 | 120 | 6 |
| 1951865 | Pro Comfort VDE Insulated Screwdriver PZ #2 x 125mm | 5706919518654 | 72 | 6 |



PHILLIPS

| ITEM NO. | DESCRIPTION | EAN | MASTER PACK | SHELF PACK |
|----------|-----------------------------------------------------|---------------|-------------|------------|
| 1951862 | Pro Comfort VDE Insulated Screwdriver PH #0 x 80 mm | 5706919518623 | 120 | 6 |
| 1951863 | Pro Comfort VDE Insulated Screwdriver PH #1 x 100mm | 5706919518630 | 120 | 6 |
| 1951864 | Pro Comfort VDE Insulated Screwdriver PH #2 x 125mm | 5706919518647 | 72 | 6 |



PARALLEL

| ITEM NO. | DESCRIPTION | EAN | MASTER PACK | SHELF PACK |
|----------|----------------------------------------------------------|---------------|-------------|------------|
| 1951868 | Pro Comfort VDE Insulated Screwdriver PARA 3.5 mm x 80mm | 5706919518685 | 120 | 6 |
| 1951869 | Pro Comfort VDE Insulated Screwdriver PARA 4mm x 100mm | 5706919518692 | 120 | 6 |
| 1951870 | Pro Comfort VDE Insulated Screwdriver PARA 2.5mm x 50mm | 5706919518708 | 120 | 6 |
| 1951881 | Pro Comfort VDE Insulated Screwdriver PARA 5.5mm x 150mm | 5706919518814 | 72 | 6 |



SCREWDRIVER SETS



1951882



1951883



1951884

| ITEM NO. | DESCRIPTION | EAN | MASTER PACK | SHELF PACK |
|----------|--------------------------------------------------------------------------------------------------------------------------------------------------------------------------------------------------|---------------|-------------|------------|
| 1951882 | 10pc Pro Comfort Screwdrivers Set: PZ #0 x 80mm, PZ #1 x 100mm, PZ #2 x 30mm, PARA 3mm x 100mm, PH #1 x 100, PH #2 x 125mm, SL 5.5mm x 100mm, SL 6.5mm x 150mm, SL 8mm x 150mm | 5706919518821 | 20 | 5 |
| 1951883 | 9pc Pro Comfort Screwdrivers Set: PZ #0 x 80mm, PZ #1 x 100mm, PZ #2 x 125mm, PARA 4mm x 100mm, PARA 5.5mm x 150mm, PARA 6.5mm x 30mm, SL 3mm x 80mm, SL 5mm x 100mm, SL 5.5mm x 100mm | 5706919518838 | 20 | 5 |
| 1951884 | 6pc Pro Comfort VDE Insulated Screwdrivers Set: PARA 2mm x 50mm, PARA 3.5mm x 80mm, PARA 4mm x 100mm, PZ #0 x 80mm, PZ #1 x 100mm, PZ #2 x 125mm | 5706919518845 | 30 | 5 |

SPECIALITY SCREWDRIVER SETS



1951885

SPINNING HEADS ON HANDLES for controlled torque in precision work
CHROME-VANADIUM (CR-V) SHAFT includes corrosion protection for longer life of the tool
STORAGE CASE INCLUDED for convenient storage

| ITEM NO. | DESCRIPTION | EAN | MASTER PACK | SHELF PACK |
|----------|-------------------------------------------------------------------------------------------------------------------------------------------------------------|---------------|-------------|------------|
| 1951885 | 5pc Precision Screwdriver Set: SL 2mm x 50mm x 136mm, SL 2.5mm x 50mm x 136mm, SL 3mm x 50mm x 136mm, PH #00 x 50mm x 136mm, PH #0 x 50mm x 136mm | 5706919518852 | 48 | 6 |

SCREWDRIVER ACCESSORIES

The 2-in-1 functionality featured on this accessory allows users to magnetise or demagnetise screwdrivers in seconds.



1953963

| ITEM NO. | DESCRIPTION | EAN | MASTER PACK | SHELF PACK |
|----------|---------------------------|---------------|-------------|------------|
| 1953963 | MAGNETISER / DEMAGNETISER | 5706919539635 | 48 | 6 |

SCREWDRIVERS & HEX KEYS

HEX KEYS

ERGONOMIC PROTOUCH™ GRIP DESIGN

SLOT MACHINED TIP

HEAT-TREATED CHROME-VANADIUM STEEL

OXIDED

T HANDLE HEX KEYS

Manufactured from high-strength and durable chrome vanadium steel. Ergonomic design to ease gripping and handling, improving the torque performance. Routed tip finish for better gripping and holding of screws. Special surface treatment to prevent oxidation and corrosion.

1. HEAT-TREATED CHROME-VANADIUM STEEL
Cr-V with high-resistant heat treatment is high-strength and durable for long tool life

2. SLOT MACHINED TIP
Routed tip finish for better gripping and holding of screws

3. ERGONOMIC PROTOUCH™ GRIP DESIGN
For comfort and better gripping to improve torque performance

4. OXIDED
Special surface treatment to prevent oxidation and corrosion

ProTouch GRIPS

'T' HANDLE HEX KEY SETS

| ITEM NO. | DESCRIPTION | EAN | MASTER PACK | SHELF PACK |
|----------|--------------------------------------------------------|---------------|-------------|------------|
| T10771 | 8pc Set MM: 2.0, 2.5, 3.0, 4.0, 5.0, 6.0, 8.0, 10.0 mm | 7897095029299 | 3 | 3 |



T10771

HOLSTER HEX KEYS SET

Durable ABS holster sets available in varying diameters, offer practicality in any use and organize tools compactly.

| ITEM NO. | DESCRIPTION | EAN | MASTER PACK | SHELF PACK |
|----------|-------------------------------------------------------------------------------|---------------|-------------|------------|
| T10755 | Short Hex Key - MM: 1.5, 2.0, 2.5, 3.0, 4.0, 5.0, 6.0, 7.0, 8.0, 10.0mm | 7897095029138 | - | 6 |
| T10756 | Long Hex Key - MM: 1.5, 2.0, 2.5, 3.0, 4.0, 5.0, 6.0, 7.0, 8.0, 10.0mm | 7897095029145 | - | 6 |
| T10757 | Ball-Ended Hex Key - MM: 1.5, 2.0, 2.5, 3.0, 4.0, 5.0, 6.0, 7.0, 8.0, 10.0 mm | 7897095029152 | - | 6 |
| T10758 | Torx Key: T6, T7, T8, T10, T15, T20, T25, T27, T30, T40 | 7897095029169 | - | 6 |



T10756

HEX AND TORX KEYS - FOLD UP SETS

Retractable set of IRWIN® Hex and Torx keys housed in a high-resistance, polyamide and fiberglass handle. Ergonomic rubber grip for greater comfort and ease of use.

| ITEM NO. | DESCRIPTION | EAN | MASTER PACK | SHELF PACK |
|----------|-----------------------------------------------------------------|---------------|-------------|------------|
| T10765 | Hex Key - MM: 2.0, 2.5, 3.0, 4.0, 5.0, 6.0, 8.0 mm | 7897095029237 | - | 6 |
| T10767 | Torx Key: T9, T10, T15, T20, T25, T27, T30, T40 | 7897095029251 | - | 6 |
| T10769 | Ball - Ended Hex Key - MM: 2.0, 2.5, 3.0, 4.0, 5.0, 6.0, 8.0 mm | 7897095029275 | - | 6 |
| T10768 | Ball - Ended Hex Key - IMPERIAL: 9pc. 5/64" - 1/4" | 7897095029268 | - | 6 |



T10765

STANDARD HEX KEY SETS

The most popular hex key sizes in one set come with permanent size markings for quick identification.

| ITEM NO. | DESCRIPTION | EAN | MASTER PACK | SHELF PACK |
|----------|--------------------------------------------------|---------------|-------------|------------|
| T10745 | Short Hex Key - IMPERIAL: 9pc. 1/16" - 3/8" | 7897095029039 | - | 5 |
| T10747 | Ball-Ended Hex Key - IMPERIAL: 9pc. 1/16" - 3/8" | 7897095029053 | - | 5 |

IRWIN®



UTILITY KNIVES & BLADES

BI-METAL UTILITY BLADES



SHATTERPROOF

TRAPEZOID BLADES
FIT MOST KNIVES

LAST 3 TIMES
LONGER*



BI-METAL BLUE BLADES

Bi-Metal is formed by welding high-speed steel edge and spring steel, having the benefit of both types: Safety & Longer Life.

IRWIN® Bi-metal Blue Blades are safer since they will not break under normal working conditions, and they help reduce the risk of injury from breaking or shattering blades. And, with the blades lasting longer than traditional carbon blades, they result in fewer blade changes which means fewer accidental cuts.

SNAP-OFF BLADES
SOFT SNAP
TECHNOLOGY

1. SHATTERPROOF

Spring steel allows the blade to bend without accidentally breaking

2. LAST 3 TIMES LONGER*

High speed steel hardened cutting edge stays sharp 3X longer than traditional carbon blades which means more cuts for the money

3. TRAPEZOID BLADES FIT MOST KNIVES

Two-notch blade design fits most utility knives

4. SNAP-OFF BLADES SOFT SNAP TECHNOLOGY

For breaking a new edge confidently

3X LONGER LIFE*
*vs. traditional carbon blades

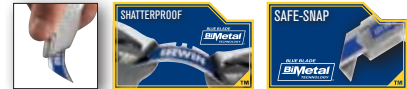

*vs IRWIN® carbon blades 10504245 / 10504561

BI-METAL BLUE TRAPEZOID BLADES

| ITEM NO. | DESCRIPTION | EAN | MASTER PACK | SHELF PACK |
|----------|---------------------------------------------------|---------------|-------------|------------|
| 10504240 | Bi-Metal Blue Trapezoid blades - 5pk | 5706915042405 | 25 | 5 |
| 10504241 | Bi-Metal Blue Trapezoid blades - 10pk | 5706915042412 | 25 | 5 |
| 10504243 | Bi-Metal Blue Trapezoid blades - 100pk, Dispenser | 5706915042436 | 5 | 1 |



BI-METAL BLUE SAFETY BLADES

All the benefits of the Bi-Metal Trapezoid Blade but with a snub nose design which helps to reduce the risk of accidental puncture wounds.

| ITEM NO. | DESCRIPTION | EAN | MASTER PACK | SHELF PACK |
|----------|---------------------------------------------------|---------------|-------------|------------|
| 10505823 | Bi-Metal 'Blue' Safety Trap Blade 5pk | 5706915058239 | 25 | 5 |
| 10505824 | Bi-Metal 'Blue' Safety Trap Blade 50pk, Dispenser | 5706915058246 | 5 | 1 |



Bi-Metal Safety Blade - Not Pointed

SNAP-OFF BI-METAL BLUE BLADES

| ITEM NO. | DESCRIPTION | EAN | MASTER PACK | SHELF PACK |
|----------|----------------------------------------------|---------------|-------------|------------|
| 10507102 | Bi-Metal 'Blue' Snap-Off Blade 18mm 5pk | 5706915071023 | - | 10 |
| 10507103 | Bi-Metal 'Blue' Snap-Off Blade 18mm 8pk | 5706915071030 | - | 10 |
| 10507104 | Bi-Metal 'Blue' Snap-Off Blade 18mm 50pk | 5706915071047 | - | 2 |
| 10507105 | Bi-Metal 'Blue' Snap-Off Blade 18mm 10 x 8pk | 5706915071054 | 50 | 10 |



CARBON STEEL UTILITY BLADES

CARBON STEEL 4-POINT TRAPEZOID BLADES

This IRWIN® innovation combines the toughness of a traditional trapezoid blade with the increased blade tip life of a snap-off blade. Scored edges give the user 4 sharp points (vs. 2 points on a standard trapezoid blade) which doubles the life of the blade. The 4 notches enable the blade to be extended to maintain blade length after snapping off sections of the blade.

2X LONGER LIFE*
*vs. traditional carbon blades



| ITEM NO. | DESCRIPTION | EAN | MASTER PACK | SHELF PACK |
|----------|----------------------------------------------|---------------|-------------|------------|
| 10508107 | 4Point Carbon Steel Blade - 5pk | 5706915081077 | 25 | 5 |
| 10508108 | 4Point Carbon Steel Blade - 10pk | 5706915081084 | 25 | 5 |
| 10508110 | 4Point Carbon Steel Blade - 100pk, Dispenser | 5706915081107 | 5 | 1 |

CARBON STEEL BLADES

Carbon blade with carbon steel cutting edge for general purpose cutting.



| ITEM NO. | DESCRIPTION | EAN | MASTER PACK | SHELF PACK |
|----------|----------------------------------------|---------------|-------------|------------|
| 10504245 | Carbon Steel Blades - 5pk | 5706915042450 | - | 5 |
| 10504246 | Carbon Steel Blades - 10pk | 5706915042467 | - | 5 |
| 10504247 | Carbon Steel Blades - 100pk, Dispenser | 5706915042474 | - | 1 |

CARBON STEEL HOOKED BLADES

Carbon blade with hooked point to protect surfaces underneath the blade.



| ITEM NO. | DESCRIPTION | EAN | MASTER PACK | SHELF PACK |
|----------|-----------------------------------------------|---------------|-------------|------------|
| 10504249 | Carbon Steel Hooked Blades - 5pk | 5706915042498 | - | 5 |
| 10504250 | Carbon Steel Hooked Blades - 10pk | 5706915042504 | - | 5 |
| 10504251 | Carbon Steel Hooked Blades - 100pk, Dispenser | 5706915042511 | - | 1 |

SNAP-OFF CARBON STEEL BLADES

Carbon blade snaps cleanly at the intended point and provides user with a regular sharp new cutting tip.



| ITEM NO. | DESCRIPTION | EAN | MASTER PACK | SHELF PACK |
|----------|---------------------------------------------|---------------|-------------|------------|
| 10504558 | Carbon Steel Snap-Off Blade 25mm 5pk | 5706915045581 | - | 5 |
| 10504559 | Carbon Steel Snap-Off Blade 25mm 10pk | 5706915045598 | - | 5 |
| 10504561 | Carbon Steel Snap-Off Blade 18mm 5pk | 5706915045611 | - | 5 |
| 10504562 | Carbon Steel Snap-Off Blade 18mm 10pk | 5706915045628 | - | 5 |
| 10504563 | Carbon Steel Snap-Off Blade 18mm 50pk | 5706915045635 | - | 1 |
| 10504567 | Carbon Steel Snap-Off Blade 9mm 10pk | 5706915045673 | - | 5 |
| 10506456 | Carbon Steel Snap-Off Blade Bulk 18mm 100pk | 5706915064568 | - | 1 |

UTILITY KNIVES & BLADES

FK SERIES FOLDING UTILITY KNIVES

The IRWIN® Folding Utility Knives range features a new collection of best-in-class knives developed from intensive research on the needs of professional users. This innovative range meets the high standards required by today's professional users – where safety, durability, convenience and comfort are the most important factors.

PATENTED BLADELOK TECHNOLOGY

LINER LOCK

16° CUTTING ANGLE AND CAST FINGER GROOVES

BUILT-IN BLADE STORAGE

FK250 FOLD-OUT SCREWDRIVER & BIT STORAGE

ALL METAL BODY

WIRE STRIPPER & BELT CLIP

1888439

FK SERIES FOLDING KNIFE

Included:

- PH2
- S1

Fold-out Screwdriver and additional bit storage

BladeLock TECHNOLOGY
KEEPS BLADE LOCKED IN

BiMetal
BLADES • LAMES • HOUES

- PATENTED BLADELOK TECHNOLOGY**
Keeps blade locked in place
- LINER LOCK**
For safe, one-handed operation
- 16° CUTTING ANGLE AND CAST FINGER GROOVES**
For ultimate comfort and control
- WIRE STRIPPER & BELT CLIP**
For built-in convenience
- BUILT-IN BLADE STORAGE**
Holds up to two additional blades (not available on FK100)
- ALL METAL BODY**
Design provides added durability (excluding FK150)
- FK250 FOLD-OUT SCREWDRIVER & BIT STORAGE**
Fits 1" insert bits for quick fixes and provides additional tool versatility (PH2 and SQ2 included)

| ITEM NO. | DESCRIPTION | EAN | MASTER PACK | SHELF PACK |
|----------|--------------------------------------------|---------------|-------------|------------|
| 1888437 | FK100 Folding Knife with 1 Bi-metal Blade | 5706918884378 | - | 5 |
| 1888438 | FK150 Folding Knife with 3 Bi-Metal Blades | 5706918884385 | - | 5 |
| 1888439 | FK250 Folding Knife with 3 Bi-Metal Blades | 5706918884392 | - | 5 |



FOLDING KNIFE

This high-quality and compact knife design features a 45° quick-change mechanism to increase both productivity and safety. In addition, the knife features an anchored belt clip, extended thumb ledge, and wire stripper. The knife comes with a Bi-Metal utility blade.

| ITEM NO. | DESCRIPTION | EAN | MASTER PACK | SHELF PACK |
|----------|---------------|---------------|-------------|------------|
| 10507695 | Folding Knife | 5706915076950 | 30 | 10 |



RETRACTABLE UTILITY KNIVES

IRWIN® offers an extensive range of retractable utility knives designed to be used in a variety of applications and to meet the needs of discerning trade professionals.

PROTOUCH™ X RETRACTABLE UTILITY KNIFE



QUICK-CHANGE BLADE MECHANISM

3-STEP RETRACTION

INCLUDES 3 BI-METAL BLADES WITH 3X LONGER LIFE

HINGED BLADE STORAGE

TRIGGER GRIP

HARD-WEARING ALUMINIUM WITH PROTOUCH™ SOFT GRIP

PROTOUCH™ X RETRACTABLE UTILITY KNIFE

Ideal for many professional trades to be used in multiple applications, in particular roofing.



- 1. QUICK-CHANGE BLADE MECHANISM**
Easy blade change with safe lock system to prevent blade from slipping during use
- 2. HINGED BLADE STORAGE**
Tool free access to storage for up to 10 blades
- 3. TRIGGER GRIP**
For cutting on the pull
- 4. HARD-WEARING ALUMINIUM WITH PROTOUCH™ SOFT GRIP**
Knife is robust, but lightweight with an ergonomic grip for added comfort and to reduce hand fatigue
- 5. 3-STEP RETRACTION**
For multiple cutting depths
- 6. INCLUDES 3 BI-METAL BLADES WITH 3X LONGER LIFE**
vs. traditional carbon blades

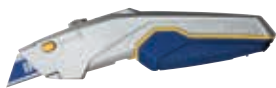

| ITEM NO. | DESCRIPTION | EAN | MASTER PACK | SHELF PACK |
|----------|-------------------------------|---------------|-------------|------------|
| 10508104 | ProTouch™ X Retractable Knife | 5706915081046 | 25 | 5 |

XP RETRACTABLE KNIFE

This knife, with a single piece steel nose and robust body sets the standard for durability. The quick-change mechanism, easy tool-free entry and 5-blade storage save users time.



| ITEM NO. | DESCRIPTION | EAN | MASTER PACK | SHELF PACK |
|----------|----------------------|---------------|-------------|------------|
| 10507404 | XP Retractable Knife | 5706915074048 | 40 | 8 |

PROTOUCH™ RETRACTABLE KNIFE

This knife has an optimised cutting angle to minimise fatigue and includes magnetic blade retention and storage for up to 5 blades.



| ITEM NO. | DESCRIPTION | EAN | MASTER PACK | SHELF PACK |
|----------|-----------------------------|---------------|-------------|------------|
| 10504236 | ProTouch™ Retractable Knife | 5706915042368 | - | 5 |

GENERAL CONSTRUCTION RETRACTABLE KNIFE

A lightweight and durable retractable knife to get all jobs done. The push and slide opening mechanism provides easy tool-free blade access for quick blade changes, and the knife parts are secured to prevent dropping/losing components.



| ITEM NO. | DESCRIPTION | EAN | MASTER PACK | SHELF PACK |
|----------|--------------------------------------|---------------|-------------|------------|
| 10508105 | General Contractor Retractable Knife | 5706915081053 | - | 5 |

UTILITY KNIVES & BLADES

PROFESSIONAL RETRACTABLE KNIFE

This general purpose knife has a lightweight, but hard-wearing aluminium body to hold up on the job. A magnet holds the working blade in place and a captive screw prevents loss during blade change.

| ITEM NO. | DESCRIPTION | EAN | MASTER PACK | SHELF PACK |
|----------|--------------------------------|---------------|-------------|------------|
| 10504238 | Professional Retractable Knife | 5706915042382 | - | 5 |



RETRACTABLE KNIFE

This professional entry-level retractable knife is highly durable, lightweight, and features an optimised cutting angle for minimal fatigue.

| ITEM NO. | DESCRIPTION | EAN | MASTER PACK | SHELF PACK |
|----------|--------------------------------|---------------|-------------|------------|
| 10504238 | Professional Retractable Knife | 5706915042382 | - | 5 |



FIXED UTILITY KNIVES

PROTOUCH FIXED KNIFE

A feature-rich fixed knife that is designed with an optimised cutting angle to minimise fatigue and a ProTouch™ for a secure grip and greater comfort in use.

| ITEM NO. | DESCRIPTION | EAN | MASTER PACK | SHELF PACK |
|----------|----------------------|---------------|-------------|------------|
| 10504237 | ProTouch Fixed Knife | 5706915042375 | - | 5 |



TOOL-FREE ENTRY for easy blade changes
BUILT-IN BLADE STORAGE holds up to 5 blades
MAGNETIC BLADE HOLDER prevents blade from falling out when casing is open
PROTOUCH™ GRIP for comfort and control

DRYWALLER FIXED KNIFE

This professional fixed knife is the ideal tool to be used in drywall cutting applications. It is specially made for working in dusty conditions that normally ruin tools. It is robust and lightweight and the slim nose for scoring makes this product unique.

| ITEM NO. | DESCRIPTION | EAN | MASTER PACK | SHELF PACK |
|----------|---------------------|---------------|-------------|------------|
| 10508103 | Drywall Fixed Knife | 5706915081039 | - | 5 |



PROFESSIONAL FIXED KNIFE

This knife features a strong die cast aluminium body with 19° angled nose for greater comfort and to reduce strain.

| ITEM NO. | DESCRIPTION | EAN | MASTER PACK | SHELF PACK |
|----------|--------------------------|---------------|-------------|------------|
| 10504239 | Professional Fixed Knife | 5706915042399 | - | 5 |



FIXED KNIFE

This professional entry-level fixed knife is highly durable, lightweight and features an optimised cutting angle for minimal fatigue.

| ITEM NO. | DESCRIPTION | EAN | MASTER PACK | SHELF PACK |
|----------|-------------|---------------|-------------|------------|
| 10507449 | Fixed Knife | 5706915074499 | 25 | 5 |



SPECIALITY KNIVES

SELF-RETRACTING KNIFE

This TUV certified safety knife is designed to minimise the risk of injury.

| ITEM NO. | DESCRIPTION | EAN | MASTER PACK | SHELF PACK |
|----------|------------------------|---------------|-------------|------------|
| 10505822 | Self Retractable Knife | 5706915058222 | - | 5 |



SPRING RETURN SHUTTLE ensures blade automatically retracts at the end of a cutting action
STRONG DIECAST ALUMINIUM BODY WITH 19° ANGLED NOSE for more comfortable cutting and to reduce strain
MULTI-FUNCTIONAL DESIGN allows for two blade settings that include normal use and as a box cutter
MAGNETISED BLADE HOLDER prevents blade from falling out
CAPTIVE BALE SCREW for easy tool-free blade changes
BUILT-IN BLADE STORAGE holds up to three blades
INCLUDES 1 SHATTERPROOF BI-METAL SAFETY BLADE WITH 3X LONGER LIFE*

*vs. IRWIN® carbon blades #10504245



PROTOUCH™ SNAP-OFF HEAVY DUTY KNIFE

SLIM NOSE DESIGN

SOLID CAST ALUMINIUM BODY AND STEEL BLADE GUIDE

SELF-LOCKING BLADE SLIDE

IRWIN

BLADE STORAGE

PROTOUCH™ GRIP

IMPACT RESISTANT HINGED END-CAP

PROTOUCH™ SNAP-OFF HEAVY DUTY KNIFE

A feature-rich, heavy-duty knife with manual screw tightening at the nose for user controlled blade security. Other features include cartridge for storing 2 blades, durable cast aluminium body with stainless steel blade guide, hinged end-cap, and ProTouch™ grip for a secure grip and greater comfort.

- 1. SELF-LOCKING BLADE SLIDE**
For fast blade adjustment on medium-duty tasks
- 2. BLADE STORAGE**
For three blades inside the removable cartridge
- 3. SOLID CAST ALUMINIUM BODY AND STEEL BLADE GUIDE**
For durability
- 4. PROTOUCH™ GRIP**
Provides excellent control
- 5. SLIM NOSE DESIGN**
For maximum visibility of the cutting surface
- 6. IMPACT-RESISTANT HINGED END-CAP**
Cannot be separated from knife body

| ITEM NO. | DESCRIPTION | EAN | MASTER PACK | SHELF PACK |
|----------|-------------------------------------------|---------------|-------------|------------|
| 10507106 | ProTouch™ Snap-Off Heavy-Duty Knife, 18mm | 5706915071061 | - | 8 |

PROTOUCH™ SNAP-OFF KNIFE

This ProTouch™ knife is designed for a variety of light- to medium-duty applications. The handle provides a secure grip and greater comfort in use and the slim nose design provides accuracy with improved visibility to cutting surfaces.

| ITEM NO. | DESCRIPTION | EAN | MASTER PACK | SHELF PACK |
|----------|--------------------------------|---------------|-------------|------------|
| 10504553 | ProTouch™ Snap-Off Knife, 25mm | 5706915045536 | - | 5 |
| 10504555 | ProTouch™ Snap-Off Knife 9mm | 5706915045550 | - | 5 |

PROFESSIONAL SNAP-OFF SCREW KNIFE

This durable snap-off knife features a screw thread for convenient user-controlled blade fixture. Blade storage for two blades inside the removable cartridge. Strong ABS body with steel blade guide. Texture grip provides improved control. Slim nose design for maximum visibility of the cutting surface. Hinged end cap cannot be separated from body.

| ITEM NO. | DESCRIPTION | EAN | MASTER PACK | SHELF PACK |
|----------|------------------------------------------------|---------------|-------------|------------|
| 10507580 | Professional Screw Knife Bi-Metal Blade - 18mm | 5706915075809 | - | 5 |

UTILITY KNIVES & BLADES

SNAP-OFF SCREW KNIFE

A professional knife featuring a screw fixture for convenient user controlled blade fixture and a strong ABS Body. The textured grip provides improved control.

| ITEM NO. | DESCRIPTION | EAN | MASTER PACK | SHELF PACK |
|----------|-----------------------------|---------------|-------------|------------|
| 10508135 | Snap-Off Screw Knife - 18mm | 5706915081350 | - | 5 |
| 10508136 | Snap-Off Screw Knife - 25mm | 5706915081367 | - | 5 |



CARPET LAYER SNAP-OFF KNIFE

This knife features a built-in metal carpet tucker for increased versatility. The solid cast aluminium body with steel blade guide provides more durability, and the lightweight and durable handle minimises fatigue. Plus, the screw thread provides convenient user controlled blade fixture.

| ITEM NO. | DESCRIPTION | EAN | MASTER PACK | SHELF PACK |
|----------|----------------------------------|---------------|-------------|------------|
| 10507843 | Carpet Layer Snap-Off Knife 18mm | 5706915078435 | 25 | 5 |



SNAP-OFF KNIFE

A popular knife format featuring self-locking blade adjustment together with a removable end-cap which can assist breakage of each blade segment.

| ITEM NO. | DESCRIPTION | EAN | MASTER PACK | SHELF PACK |
|----------|----------------------------------------------------|---------------|-------------|------------|
| 10506543 | Snap-Off Knife 9mm | 5706915065435 | - | 5 |
| 10506546 | Snap-Off Knife Bulk 9mm 24pk | 5706915065466 | 120 | 24 |
| 10506544 | Snap-Off Knife 18mm | 5706915065442 | - | 5 |
| 10506547 | Snap-Off Knife Bulk 18mm 24pk | 5706915065473 | 120 | 24 |
| 10507446 | Snap-Off Knife Bulk with 18mm Bi-Metal Blade 100pk | 5706915074468 | - | 100 |



IRWIN®

STRAIT-LINE®



TAPE MEASURES

PROFESSIONAL TAPE MEASURE RANGE

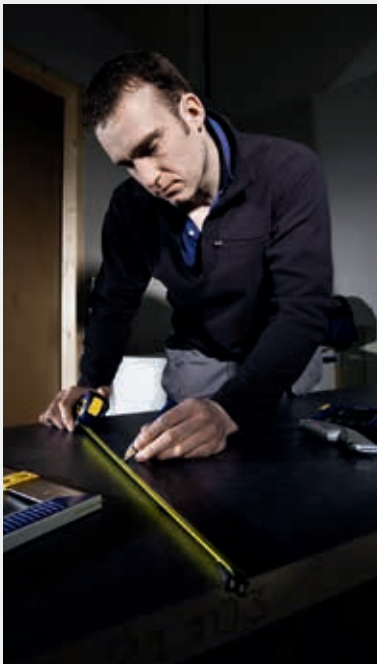

ProTouch™ GRIPS

1. **BLADE STAND-OUT**
3m (10ft): 1,4m (4-2/3ft) / 5m (16ft): 1,8m (6ft) / 8m (26ft): 2,3m (7-1/2ft)
2. **NYLON COATING**
For 2X longer life vs. standard IRWIN® tapes
3. **3-RIVET END HOOK**
With reinforced metal backing for durability
4. **MAGNETIC END HOOK**
For working with metal structures
5. **FAST LOCK**
For quick and easy blade control
6. **DOUBLE-SIDED PRINTING**
For greater visibility and convenience
7. **PROTOUCH™ GRIP**
For comfort in use

| ITEM NO. | DESCRIPTION | BLADE WIDTH | EAN | MASTER PACK | SHELF PACK |
|--------------------------|-----------------------------------------------|-------------|---------------|-------------|------------|
| METRIC | | | | | |
| 10507790 | Professional 3m Tape Measure | 16mm | 5706915077902 | 60 | 6 |
| 10507791 | Professional 5m Tape Measure | 19mm | 5706915077919 | 60 | 6 |
| 10507792 | Professional 8m Tape Measure | 25mm | 5706915077926 | 48 | 6 |
| 10508059 | Professional 5m Tape Measure, 12pcs Bulk | 19mm | 5706915080599 | - | 12 |
| 10508060 | Professional 8m Tape Measure, 12pcs Bulk | 25mm | 5706915080605 | - | 12 |
| METRIC / IMPERIAL | | | | | |
| 10507793 | Professional 3m/10ft Tape Measure | 16mm | 5706915077933 | 60 | 6 |
| 10507794 | Professional 5m/16ft Tape Measure | 19mm | 5706915077940 | 60 | 6 |
| 10507795 | Professional 8m/26ft Tape Measure | 25mm | 5706915077957 | 48 | 6 |
| 10508062 | Professional 5m/16ft Tape Measure, 12pcs Bulk | 19mm | 5706915080629 | - | 12 |



10507791

STANDARD TAPE MEASURE RANGE



10507788

BLADE STAND-OUT 3m (10ft): 1,2m (4ft) / 5m (16ft):
1,8m (6ft) / 8m (26ft): 2,3m (7-1/2ft)

ACRYLIC COATING for rust and abrasion protection

THREE RIVET END HOOK with reinforced metal backing
for durability

SLIDING LOCK for easy blade control

ABS PLASTIC CASE WITH PROTOUCH™ GRIP for comfort
and durability

| ITEM NO. | DESCRIPTION | BLADE WIDTH | EAN | MASTER PACK | SHELF PACK |
|--------------------------|--------------------------------------|-------------|---------------|----------------|---------------|
| METRIC | | | | | |
| 10507784 | Standard 3m Tape Measure | 13mm | 5706915077841 | 60 | 6 |
| 10507785 | Standard 5m Tape Measure | 19mm | 5706915077858 | 60 | 6 |
| 10507786 | Standard 8m Tape Measure | 25mm | 5706915077865 | 48 | 6 |
| 10508052 | Standard 3m Tape Measure, 12pcs Bulk | 13mm | 5706915080520 | - | 12 |
| 10508053 | Standard 5m Tape Measure, 12pcs Bulk | 19mm | 5706915080537 | - | 12 |
| 10508054 | Standard 8m Tape Measure, 12pcs Bulk | 25mm | 5706915080544 | - | 12 |
| METRIC / IMPERIAL | | | | | |
| 10507787 | Standard 3m/10ft Tape Measure | 13mm | 5706915077872 | 60 | 6 |
| 10507788 | Standard 5m/16ft Tape Measure | 19mm | 5706915077889 | 60 | 6 |
| 10507789 | Standard 8m/26ft Tape Measure | 25mm | 5706915077896 | 48 | 6 |

CHALK REELS

IRWIN® STRAIT-LINE® has manufactured chalk reels designed with the end-user in mind for more than 50 years. The new chalk reel range features larger chalk fill openings designed for ease and speed and delivers best-in-class line strength and reel durability to hold up to jobsite wear and tear.

MACH6™ CHALK REEL

NEW



MACH6™ CHALK REEL



6X FASTER*

*as compared to traditional chalk reels

1. **EASY FILL & LOCK TOP**
Large, 90°-turn locking top for quick chalk fill and easy access to reel internals
2. **6:1 GEAR RATIO**
Rewinds the line 6X faster than traditional chalk reels
3. **2.5X STRONGER HI-TENSILE LINE**
For fewer breaks and for use on rough, abrasive surfaces
4. **OPEN ACCESS BACK PANEL**
Allows for quick line change and cleaning
5. **METAL DRIVE GEAR**
Resists gear failure under heavy load
6. **ROBUST STEEL HANDLE & LARGE ERGONOMIC CLUTCH**
For increased durability and torque plus easy line release
7. **WIDE-PRONG HOOK**
For secure anchoring
8. **DURABLE ALUMINIUM HOUSING**
Provides impact resistance

| ITEM NO. | DESCRIPTION | EAN | MASTER PACK | SHELF PACK |
|----------|----------------------------------------|---------------|-------------|------------|
| 10507681 | Strait-Line MACH6™ Chalk Reel 30m/100' | 5706915076813 | - | 6 |
| 10507684 | MACH6™ Reel 30m/100' + Blue Chalk 113g | 5706915076844 | - | 8 |



10507684

STRAIT-LINE®

SPEEDLINE PRO™ CHALK REEL



10507794

NEW



2.5X
STRONGER LINE*

3X FASTER*

EASY FILL & LOCK TOP for quick chalk fill and easy access to reel internals
2.5X STRONGER HI-TENSILE LINE for fewer breaks
3:1 GEAR RATIO rewinds line 3X faster than traditional chalk reels
ROBUST STEEL HANDLE & LARGE ERGONOMIC CLUTCH for increased durability, strength and torque
WIDE PRONG HOOK for secure anchoring
LIGHTWEIGHT ABS HOUSING withstands jobsite wear and tear

| ITEM NO. | DESCRIPTION | EAN | MASTER PACK | SHELF PACK |
|----------|-------------------------------------------------|---------------|-------------|------------|
| 10507676 | SPEEDLINE PRO Chalk Reel 30m/100' | 5706915076769 | 144 | 6 |
| 10507677 | SPEEDLINE PRO Chalk Reel 30m/100', 24 pcs, Bulk | 5706915076776 | - | 24 |
| 10507682 | SPEEDLINE PRO Reel 30m/100' + Blue Chalk 113g | 5706915076820 | 72 | 3 |

*vs traditional chalk reels

CLASSIC CHALK REEL



10507678

70% WIDER DOOR for quick and easy chalk fill
ABRASION RESISTANT LINE provides 5-6 strikes per pull
1:1 GEAR RATIO rewinds line
HEAVY-DUTY ALUMINIUM, ROBUST STEEL HANDLE, LARGE CENTER HUB for increased durability

| ITEM NO. | DESCRIPTION | EAN | MASTER PACK | SHELF PACK |
|----------|-----------------------------------------------------|---------------|-------------|------------|
| 10507678 | Classic Aluminium Chalk Reel 15m/50' | 5706915076783 | 144 | 6 |
| 10507679 | Classic Aluminium Chalk Reel 30m/100' | 5706915076790 | 144 | 6 |
| 10507680 | Classic Aluminium Chalk Reel 30m/100', 24 pcs, Bulk | 5706915076806 | - | 24 |
| 10507683 | Classic Aluminium Reel 30m/100' + Blue Chalk 113g | 5706915076837 | 72 | 3 |

MARKING CHALK

IRWIN® STRAIT-LINE® marking chalks have an innovative flip-top cap that keeps the chalk in the bottle where you want it. The flip-top cap seals the chalk in an airtight chamber, keeping out moisture and reducing the risk of clumping.

Marking Chalk Colour Permanence & Application Guide

Blue Chalk - Standard indoor/outdoor (1 week) Red Chalk - Outdoor permanent (up to 2 months).

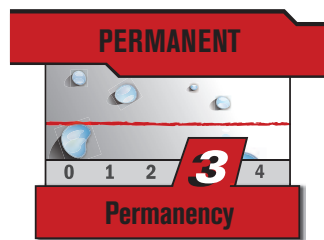
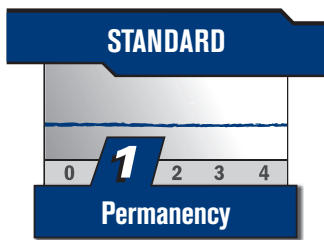

65201

64901

64902

| ITEM NO. | DESCRIPTION | EAN | MASTER PACK | SHELF PACK |
|----------|---------------------------------|---------------|-------------|------------|
| 64801ZR | Blue Marking Chalk 4oz/113g | 0024721500014 | 24 | 6 |
| 64802 | Red Marking Chalk 4oz/113g | 0024721500052 | 24 | 6 |
| 64901 | Blue Marking Chalk 8oz/227g | 0024721500076 | 24 | 6 |
| 64902 | Red Marking Chalk 8oz/227g | 0024721500120 | 24 | 6 |
| 65201 | Blue Marking Chalk 2.5lbs/1.1kg | 0024721652010 | 6 | 1 |

REPLACEMENT LINES

| ITEM NO. | DESCRIPTION | EAN | MASTER PACK | SHELF PACK |
|----------|--------------------------------------|----------------|-------------|------------|
| 1932892 | 15m/50' Polyester Replacement Line | 00042526936913 | 144 | 6 |
| 1932893 | 30m/100' Polyester Replacement Line | 00042526936920 | 144 | 6 |
| 1932894 | 30m/100' Hi-Tensile Replacement Line | 00042526936937 | 144 | 6 |



1932894

STRAIT-LINE CRAYONS



66401ZR

| ITEM NO. | DESCRIPTION | EAN | MASTER PACK | SHELF PACK |
|----------|----------------------------|---------------|-------------|------------|
| 66401ZR | Red Crayon, Bulk 12pk | 0024721664013 | - | 1 |
| 66404 | Black Crayon, Bulk 12pk | 0024721664044 | - | 1 |
| 66406 | Yellow Crayon, Bulk 12pk | 0024721664068 | - | 1 |
| 666012 | Red Crayon, Carded 2 pk | 0024721061904 | - | 12 |
| 666042 | Black Crayon, Carded 2 pk | 0024721061935 | - | 12 |
| 666062 | Yellow Crayon, Carded 2 pk | 0024721061959 | - | 12 |

FOR USE ON OILY, slick, wet, cold or dry surfaces
IDEAL FOR CONCRETE, ceramics, rubber, metal, paper and cardboard
NON-TOXIC and waterproof

STRAIT-LINE CARPENTER PENCILS & SHARPENER



66300

| ITEM NO. | DESCRIPTION | EAN | MASTER PACK | SHELF PACK |
|----------|----------------------------|---------------|-------------|------------|
| 233250 | Carpenter Pencil Sharpener | 0024721007087 | - | 25 |
| 66300 | Medium Pencil, Bulk 12pcs | 0024721663009 | 144 | 12 |
| 66305SL | Medium Pencil, Box 72pcs | 0024721028150 | 1440 | 72 |



233250



TOOL STORAGE

Professional end-users have high demands for their tools. IRWIN® understands these demands. Toughness and value are qualities you'll find in every IRWIN® toolbag and organiser.

SOFT-SIDE TOOL ORGANISER

Long enough to carry saws and levels with space and pockets for other tools. Size: 600 x 260 x 400mm.

| ITEM NO. | DESCRIPTION | EAN | MASTER PACK | SHELF PACK |
|----------|-----------------------------------|---------------|-------------|------------|
| 10505369 | Soft-Sided Tool Organiser, Zipper | 5706915053692 | 5 | 1 |



BIGFOOT TOOL BAG

Versatile large capacity bag with a waterproof base, keeps plans and documents dry, even on wet or muddy ground. Size: 222 x 406 x 305mm.

| ITEM NO. | DESCRIPTION | EAN | MASTER PACK | SHELF PACK |
|----------|------------------|---------------|-------------|------------|
| 10506529 | Bigfoot Tool Bag | 5706915065299 | 4 | 4 |



DOUBLE WIDE TOOL BAG

Two large compartments for hand tools, power tools and smaller compartments for screws and nails. As strong as a tool box but lightweight and easier to carry. Size: 140 x 508 x 324mm.

| ITEM NO. | DESCRIPTION | EAN | MASTER PACK | SHELF PACK |
|----------|----------------------|---------------|-------------|------------|
| 10506531 | Double Wide Tool Bag | 5706915065312 | 4 | 4 |



TOOL TOTE

Designed like the traditional metal tool tote but lightweight and easier to carry. Wide top opening for easy access and loops to carry blueprints or a level. Size: 210 x 419 x 260mm.

| ITEM NO. | DESCRIPTION | EAN | MASTER PACK | SHELF PACK |
|----------|-------------|---------------|-------------|------------|
| 10506532 | Tool Tote | 5706915065329 | 4 | 4 |



PROFESSIONAL SOFT-SIDE TOOL ORGANISER

Small, lightweight and strong with zip fastening for security. Padded handle features reinforced stitching for extra strength. Extra wide opening provides easy access to all tools. Size: 440 x 285 x 190mm.

| ITEM NO. | DESCRIPTION | EAN | MASTER PACK | SHELF PACK |
|----------|------------------------------|---------------|-------------|------------|
| 10503820 | PRO Soft Side Tool Organiser | 5706915038200 | 4 | 4 |



PROFESSIONAL LARGE TOOL ORGANISER

Large capacity storage with top opening for quick and easy access. False bottom provides separate storage for important items. Durable plastic bottom is water resistant. Reinforced handle features extra strength rivets. Size: 420 x 350 x 245mm.

| ITEM NO. | DESCRIPTION | EAN | MASTER PACK | SHELF PACK |
|----------|--------------------------|---------------|-------------|------------|
| 10503818 | PRO Large Tool Organiser | 5706915038187 | 4 | 4 |





PROFESSIONAL UTILITY TOOL ORGANISER

Enough capacity to carry range of tools and accessories. Pockets and compartments designed to provide better organisation. Bottom made of tough wear resistant plastic. Reinforced rivets throughout for added durability. Size: 320 x 250 x 350mm.

| ITEM NO. | DESCRIPTION | EAN | MASTER PACK | SHELF PACK |
|----------|----------------------------|---------------|-------------|------------|
| 10503819 | PRO Utility Tool Organiser | 5706915038194 | 4 | 4 |



BUILDERS NAIL & TOOL POUCH

Consists of vertical tool or fastener storage that attaches directly to a belt. Designed to be worn for left or right hand access. Size: 290 x 305mm.

| ITEM NO. | DESCRIPTION | EAN | MASTER PACK | SHELF PACK |
|----------|----------------------------|---------------|-------------|------------|
| 10506534 | Builders Nail & Tool Pouch | 5706915065343 | 25 | 5 |



ELECTRICIAN'S UTILITY POUCH

Electrician's utility pouch, designed for left- or right-handed use. Back wall slots for long handled tools. Front pockets for smaller tools. Size: 190 x 290mm.

| ITEM NO. | DESCRIPTION | EAN | MASTER PACK | SHELF PACK |
|----------|-----------------------------|---------------|-------------|------------|
| 10506535 | Electrician's Utility Pouch | 5706915065350 | 25 | 5 |



PROFESSIONAL STRUCTURAL FOAM TOOLBOX

A heavy-duty structural foam, unlike most plastic or metal tool boxes, this box will stand years of use and abuse. Size: 760 x 365 x 320mm

| ITEM NO. | DESCRIPTION | EAN | MASTER PACK | SHELF PACK |
|----------|-----------------------------|---------------|-------------|------------|
| 10503817 | PRO Structural Foam Toolbox | 5706915038170 | 4 | 4 |

PROFESSIONAL KNEEPADS

I-GEL™ KNEEPADS

These comfortable and safe kneepads are made of perforated Neoprene material with impact resistant I-Gel inserts. The double straps do not restrict blood flow and the pads are notched for comfort when standing.

| ITEM NO. | DESCRIPTION | EAN | MASTER PACK | SHELF PACK |
|----------|-----------------|---------------|-------------|------------|
| 10503830 | I-Gel™ Kneepads | 5706915038309 | 6 | 6 |

ALL-TERRAIN KNEEPADS

Wide-body keeps stance more stable on uneven surfaces. Foam cushion under pad protects knee from rough surfaces.

| ITEM NO. | DESCRIPTION | EAN | MASTER PACK | SHELF PACK |
|----------|----------------------|---------------|-------------|------------|
| 10503831 | All-Terrain Kneepads | 5706915038316 | 6 | 6 |

SWIVEL-FLEX KNEEPADS

Convex cap design provides better pivoting and less resistance, giving greater manoeuvrability across textured surfaces.

| ITEM NO. | DESCRIPTION | EAN | MASTER PACK | SHELF PACK |
|----------|----------------------|---------------|-------------|------------|
| 10503832 | Swivel-Flex Kneepads | 5706915038323 | 6 | 6 |



PROFESSIONAL WORK GLOVES

GENERAL CONSTRUCTION GLOVES

The construction gloves feature two layers of synthetic suede on the palm, thumb and fingers for comfort and extended wear. The rubberised finger tips provide better gripping and the knuckles are padded with perforated Neoprene for breathability and protection. The gloves are form-fitted for improved fit and dexterity.

| ITEM NO. | DESCRIPTION | EAN | MASTER PACK | SHELF PACK |
|----------|---------------------------------|---------------|-------------|------------|
| 10503822 | General Construction Gloves, L | 5706915038224 | 24 | 6 |
| 10503823 | General Construction Gloves, XL | 5706915038231 | 24 | 6 |



EXTREME CONDITIONS GLOVES

These gloves, designed for extreme conditions, are made from a fleece lined stretch material for added warmth and better fit with a non-slip reinforced palm, thumb and fingertips and form-fitting, breathable stretch materials added for comfort. Also, they include a convenient terry cloth insert for brow wipes.

| ITEM NO. | DESCRIPTION | EAN | MASTER PACK | SHELF PACK |
|----------|-------------------------------|---------------|-------------|------------|
| 10503824 | Extreme Conditions Gloves, L | 5706915038248 | 24 | 6 |
| 10503825 | Extreme Conditions Gloves, XL | 5706915038255 | 24 | 6 |



HEAVY-DUTY JOBSITE GLOVES

These gloves are designed for harsh applications and rough materials, without losing dexterity. The grip-reinforced palm, thumb and fingertips provide extra durability. Knuckles are padded with perforated Neoprene for breathability and protection.

| ITEM NO. | DESCRIPTION | EAN | MASTER PACK | SHELF PACK |
|----------|-------------------------------|---------------|-------------|------------|
| 10503826 | Heavy-Duty Jobsite Gloves, L | 5706915038262 | 24 | 6 |
| 10503827 | Heavy-Duty Jobsite Gloves, XL | 5706915038279 | 24 | 6 |



CARPENTER GLOVES

The carpenter gloves have an open finger design to allow for better dexterity. Their reinforced palm, thumb and fingertips provide extra durability and protection. Knuckles are padded with perforated Neoprene for breathability and protection.

| ITEM NO. | DESCRIPTION | EAN | MASTER PACK | SHELF PACK |
|----------|----------------------|---------------|-------------|------------|
| 10503828 | Carpenter Gloves, L | 5706915038286 | 24 | 6 |
| 10503829 | Carpenter Gloves, XL | 5706915038293 | 24 | 6 |



IRWIN[®]

hilmor[®]



PIPE AND TUBE BENDERS

With the IRWIN® Hilmor® range of tube benders, you can be ready to tackle any job with ease. All machines feature precision tooling to give a smooth, accurate bend every time across a large range of sizes.

GLM HAND BENDING MACHINE

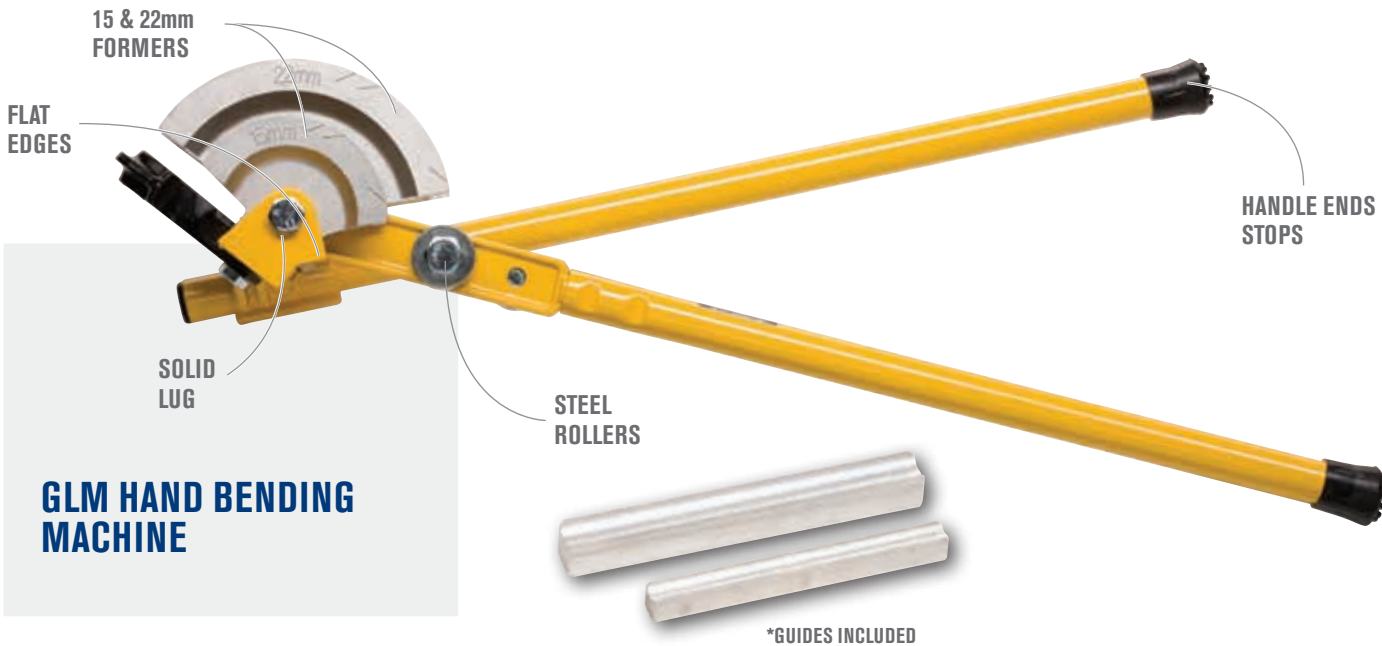

GLM HAND BENDING MACHINE

- 1. FORMERS SUPPORTED ON BOTH SIDES**
Prevents twisting under heavy loading
- 2. DURABLE, HARD-WEARING STEEL ROLLERS**
Last much longer than aluminium
- 3. SOLID LUG**
Allows the pipe bender to be held firmly between vice jaws
- 4. HEAVY-GAUGE FORMERS (15mm & 22mm)**
Won't lose their shape and include degree marks on the casting for 'at-a-glance' accuracy
- 5. FLAT EDGES TO THE BRACKET ARM**
Allow the GLM to be used in workshop vice for convenient bending
- 6. HANDLE END STOPS WITH STEEL INSERTS**
Protect user hands during bending, eliminate piercing and increase durability

| ITEM NO. | DESCRIPTION | EAN | MASTER PACK | SHELF PACK |
|----------|----------------------------------|---------------|-------------|------------|
| T591057 | GLM Hand Bending Machine 15/22mm | 0686182000016 | - | 1 |
| T660032 | Hook stop and bolt for GLM | 0686182001006 | - | 1 |



MULTI-MINI HAND BENDER

The IRWIN® Hilmor® Multi-Mini bender is a small lightweight bender that is able to bend 6, 8 & 10mm copper tube in one convenient machine. The Multi-Mini is able to produce bends of 180°

| ITEM NO. | DESCRIPTION | EAN | MASTER PACK | SHELF PACK |
|----------|----------------------------------------------------------------|---------------|-------------|------------|
| T676810 | Multi-Mini Tube Bender 6, 8, 10mm (Root Radii 22.5, 20 & 15mm) | 0686182000061 | - | 8 |



ROLLER PIPE CUTTERS

Designed to cut steel pipe, this tool has one fast cutting wheel and two wide rollers. As well as keeping the cutter squarely on track, the rollers smooth down the surface leaving a clean-cut ready for jointing or threading.

| ITEM NO. | DESCRIPTION | EAN | MASTER PACK | SHELF PACK |
|----------|---------------------------------------|---------------|-------------|------------|
| T202 | Roller Pipe Cutter, 1/8"-2" (10-60mm) | 0734442115564 | - | 1 |
| T202DF | Roller with Pin T202 | 0734442137641 | - | 1 |
| T202EF | Wheel with Pin T202 | 0734442131526 | - | 1 |



TUBE CUTTERS AND SPARE WHEELS

Exceptionally thin, fast cutting wheel and two rollers to ensure the cutting wheel is held squarely on the tube resulting in a square cut. Fitted with wide rollers to hold the tube square against the cutting wheel to prevent "tramlining."

| ITEM NO. | DESCRIPTION | EAN | MASTER PACK | SHELF PACK |
|----------|-------------------------------|---------------|-------------|------------|
| T20030C | Tube Cutter, 3-30mm | 0734442118084 | - | 6 |
| T20045 | Tube Cutter, 15-45mm | 0734442118183 | - | 4 |
| T20030CD | Wheel for Tube Cutter T20030C | 0734442117964 | - | 1 |
| T20045D | Wheel for Tube Cutter T20045 | 0734442132004 | - | 1 |



PLASTIC PIPE CUTTERS

The T850026 pipe cutter features a "V" shaped blade which allows for off-centre motion reducing tube deformation. The specially hardened steel blade also gives greater cutting pressure with less effort making it easier to use. IRWIN's PVC cutter has a simple one-handed ratcheting operation that provides smooth cutting and clean pipe ends. Plus, the rubberised grips provide confident, safe handling.

| ITEM NO. | DESCRIPTION | EAN | MASTER PACK | SHELF PACK |
|----------|--------------------------|---------------|-------------|------------|
| T850026 | 26mm Plastic Pipe Cutter | 0686182000221 | - | 10 |
| 10507485 | 45mm PVC Tube Cutter | 5706915074857 | - | 4 |



TUBE BENDERS

This tube bender is made from strong precision die-castings with integral formers and guides. This makes it lightweight, easy to use and accurate. Each of the benders is suitable for bending three sizes of copper, brass, aluminium or steel tubing.

| ITEM NO. | DESCRIPTION | EAN | MASTER PACK | SHELF PACK |
|----------|-----------------------------------|---------------|-------------|------------|
| T210 | Mini Tube Bender 3, 4, 6mm Copper | 0734442144052 | 48 | 4 |



hilmor®

MANUAL BENDING MACHINES

EL RANGE CONDUIT BENDING MACHINES AND SPARE PARTS

The IRWIN® Hilmor® EL range is easily portable and the EL25 is the lightest conduit bender available and will fit into most car boots.

| ITEM NO. | DESCRIPTION | EAN | MASTER PACK | SHELF PACK |
|----------|------------------------------------------------------------|---------------|-------------|------------|
| T090700 | EL25 Machine & Pipe Vice | 0686182000580 | - | 1 |
| T090700B | EL25 & Vice + 20 / 25mm Formers | 0686182000566 | - | 1 |
| T113100D | EL32 & Vice + 20 / 25 / 32mm Formers | 0686182000634 | - | 1 |
| T090751 | Stop bar for EL25 | 0686182000726 | - | 1 |
| T620103 | Tube stop for EL25, EL32 | 0686182000702 | - | 1 |
| T120422 | Centre pin for EL25, EL32 | 0686182000740 | - | 1 |
| T113112 | Bending lever with roller for EL25, EL32 | 0686182000733 | - | 1 |
| T102010 | Grooved roller for EL25, EL32 | 0686182000696 | - | 1 |
| T120465 | Roller pin for EL25, EL32 | 0686182000757 | - | 1 |
| T090757 | Safety pin and chain for EL25, EL32 | 0686182000689 | - | 1 |
| T529827 | "Terry" retaining pins (in packs of 5 pins) for EL25, EL32 | 0686182000771 | - | 1 |



CONDUBEND AND SPARE PARTS

The unique IRWIN® Hilmor® Condubend is a 20 & 25mm conduit bender all-in-one. Complete with in-built carrying handle and precision tough aluminium former that makes it an easily portable machine.

| ITEM NO. | DESCRIPTION | EAN | MASTER PACK | SHELF PACK |
|----------|---------------------------------------|---------------|-------------|------------|
| T702025 | Condubend (Std Vice) | 0686182000795 | - | 1 |
| T660084 | Centre pin and circlips for Condubend | 0686182000856 | - | 1 |



CM RANGE COPPER BENDING MACHINES AND SPARE PARTS

The CM range of tube benders are easily portable with in-built carrying handles, they are used with aluminium formers making them the lightest machines available.

| ITEM NO. | DESCRIPTION | EAN | MASTER PACK | SHELF PACK |
|----------|------------------------------------------------------------|---------------|-------------|------------|
| T620100A | CM35 Machine only | 0686182002706 | - | 1 |
| T620100J | CM35 & 15, 22, 28mm Tooling | 0686182000078 | - | 1 |
| T630500A | CM42 Machine only | 0686182002843 | - | 1 |
| T620103 | Tube stop for CM35, CM42 | 0686182000702 | - | 1 |
| T120422 | Centre pin for CM35, CM42 | 0686182000740 | - | 1 |
| T630519 | Bending lever assembly for CM35, CM42 | 0686182000900 | - | 1 |
| T090757 | Safety pin and chain for CM35, CM42 | 0686182000689 | - | 1 |
| T529827 | "Terry" retaining pins (in packs of 5 pins) for CM35, CM42 | 0686182000771 | - | 1 |
| T201030 | Extension tube for CM42 | 0686182000931 | - | 1 |



HEAVY-DUTY UNIVERSAL PORTABLE BENDER AND SPARE PARTS

This bender is known for its versatility due to a single universal roller for all forms of pipe. The dual position tube locations are set for copper and conduit, and an adjustable quadrant gives precise repeatable bends.

| ITEM NO. | DESCRIPTION | EAN | MASTER PACK | SHELF PACK |
|----------|---------------------------------------------|---------------|-------------|------------|
| TUL223 | Universal Portable Bender, Machine Only | 0734442144489 | 6 | 1 |
| T620103 | Tube stop for TUL223 | 0686182000702 | - | 1 |
| T220D | Tube locator arm pin with spring for TUL223 | 0734442171003 | - | 1 |



IRWIN®



MASONRY DRILLING

A DRILL BIT FOR EVERY MATERIAL

| | | SPEEDHAMMER PLUS | SPEEDHAMMER POWER | SPEEDHAMMER MAX | MASONRY | GRANITE | CORDLESS MULTI | GLASS & TILE | DIAMOND | HSS PRO | HSS COBALT | HSS TIN | TCT | TURBOMAX | STEP DRILL | BLUE GROOVE 4X/6X | BLUE GROOVE POWER | AUGER BITS | BRAD POINT |
|-----------------------------------|---------------------------|-------------------|-------------------|-----------------|-------------------|---------|----------------|--------------|---------|------------------|------------|---------|-----|----------|------------|-------------------|-------------------|------------|------------|
| | | HAMMER DRILL BITS | | | ROTARY DRILL BITS | | | | | METAL DRILL BITS | | | | | | WOOD DRILL BITS | | | |
| PAGE | | 85 | 83 | 89 | 93 | 94 | 92 | 95 | 95 | 104 | 101 | 103 | 112 | 99 | 111 | 116 | 115 | 119 | 120 |
| MASONRY | | | | | | | | | | | | | | | | | | | |
| | REBAR REINFORCED CONCRETE | ○ | ● | ● | | ○ | | | | | | | | | | | | | |
| | CONCRETE | ● | ● | ● | ● | ● | ○ | | | | | | | | | | | | |
| | NATURAL STONE | ● | ● | ● | ● | ● | ○ | | | | | | | | | | | | |
| | CONCRETE BLOCKS | ● | ● | ● | ● | ● | ○ | | | | | | | | | | | | |
| | AERATED CONCRETE | ● | ● | ● | ● | ● | ● | | | | | | | | | ○ | ○ | | |
| | BRICK | ● | ● | ● | ● | ● | ● | | | | | | | | | | | | |
| | HOLLOW BRICK | ○ | ○ | ○ | ● | ● | ● | ○ | | | | | | | | | | | |
| | ROOF TILE | ○ | ○ | | ○ | ○ | ● | ○ | | | | | | | | | | | |
| | GYPSUM BOARD | ○ | ○ | | ● | ● | ● | | | | | | | | | ○ | ○ | | |
| | FIBER CEMENT BOARD | ○ | ○ | | ● | ○ | ● | | | | | | | | | | | | |
| | GRANITE | ○ | ○ | ○ | ● | ● | ○ | | ● | | | | | | | | | | |
| | MARBLE | ○ | ○ | ○ | ○ | ● | ● | ○ | ● | | | | | | | | | | |
| | SLATE | ○ | ○ | | ● | ● | ● | ○ | ● | | | | | | | | | | |
| | ETERMIT | ○ | ○ | | ● | ○ | ● | ● | | | | | | | | | | | |
| | CERAMIC TILE | | | | ○ | ○ | ● | ● | ● | | | | | | | | | | |
| | HARD DENSITY TILE | | | | | | ● | | ● | | | | | | | | | | |
| | GLASS | | | | | | ○ | ● | | | | | | | | | | | |
| WOOD & BOARD MATERIALS | | | | | | | | | | | | | | | | | | | |
| | SOFT WOOD | | | | | | ● | | | ○ | ○ | ○ | ○ | ● | | ● | ● | ● | ● |
| | HARD WOOD | | | | | | ● | | | ○ | ○ | ○ | ○ | ● | | ● | ● | ● | ● |
| | NAIL-EMBEDDED WOOD | | | | | | | | | ○ | ○ | ○ | ○ | ○ | | | ● | | |
| | CHIPBOARD | | | | | | ● | | | ○ | ○ | ○ | ○ | ● | | ○ | ○ | ○ | ● |
| | LAMINATED | | | | | | ● | | | ○ | ○ | ○ | ○ | ● | | ○ | ○ | ○ | ● |
| METAL & PLASTIC | | | | | | | | | | | | | | | | | | | |
| | MILD STEEL | | | | | | | | | ● | ○ | ● | ○ | ● | ● | | | | |
| | HIGH-ALLOYED STEEL | | | | | | | | | ○ | ● | ● | ● | ○ | ○ | | | | |
| | SHEET METAL | | | | | | ● | | | ● | ● | ● | ○ | ● | ● | | | | |
| | STAINLESS STEEL | | | | | | | | | ○ | ● | ○ | ○ | ○ | ○ | | | | |
| | CAST IRON | | | | | | ● | | | ○ | ● | ○ | ● | ○ | | | | | |
| | ALUMINIUM | | | | | | ● | | | ● | ○ | ● | ○ | ● | ● | | | | |
| | NON-FERROUS METAL | | | | | | ● | | | ● | ○ | ● | ○ | ● | ● | | | | |
| | PLASTICS | | | | | | ● | | | ● | ○ | ● | | ● | ● | | | | |

● = Especially suitable. Recommended for this material.
○ = Suitable

IRWIN® Drill Bits are available in sets. Go to the Drilling Sets section, starting on page 134, for more details.

IRWIN® now offers a comprehensive line-up of circular saw blades for professional tool users. From the jobsite, to the fine woodworking shop, IRWIN® offers a blade for every user need.



The origins of Joran® go back to May 1944 at which time, good friends Paul Jensen and Herman Reinholdt formed the company Jensen and Reinholdt in Hvidovre, Denmark. They initially began producing masonry drill bits and later in 1955 expanded the production line to hammer drill bits.

Both product lines were characterised by uncompromising quality and were mainly offered to the building and construction industry. IRWIN® is committed to continue the original values of these products by delivering state of the art of Power Tool Accessories. The masonry drill bits range is no exception to this, and continues to fulfill the highest industry standards.

The Joran SPEEDHAMMER™ Plus and SPEEDHAMMER™ Power have the certification of “Prüfgemeinschaft Mauerbohrer” e.V. (PGM), which is the official and independent marking validating the standards of masonry drill bits. The mark is granted only to manufacturers fulfilling the following:

- state-of-the-art manufacturing under use of a quality assurance system
- yearly inspections of the produced drill bits by independent institutes

The inspection requirements are developed by the national approval bodies for anchors in co-operation with leading manufacturers of masonry drill bits and anchors. The Steering Committee of PGM® also carries out appropriate investigations in order to assure the suitability of masonry drill bits for anchor fixings.

New types of drills bits get the inspection mark only after extensive testing has been carried out, ensuring the required suitability and performance.

HAMMER DRILL BITS



SPEEDHAMMER® POWER



SPEEDHAMMER® PLUS



SPEEDHAMMER® MAX

ROTARY DRILL BITS



CORDLESS MULTI



MASONRY



GRANITE

SPECIALITY

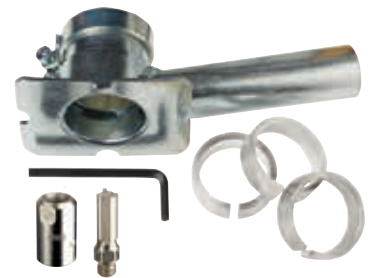

MORTAR RAKES



M-SYSTEM

SPEEDHAMMER™ POWER



LONGEST LASTING IRWIN® HAMMER DRILL BIT EVER

The range of SPEEDHAMMER™ Power drill bits is the most powerful masonry bit available from IRWIN®. The unique tip design with 2X more carbide* is optimised for fast, continuous drilling, even through reinforced concrete, delivering superior performance and 2X longer life*. The SPEEDHAMMER™ POWER bit has a high-performance tip that's manufactured with 2X more carbide*. It easily powers through 2X more concrete and rebar than traditional masonry bits. When long life and durability are crucial, depend on the IRWIN® SPEEDHAMMER™ Power Bit.

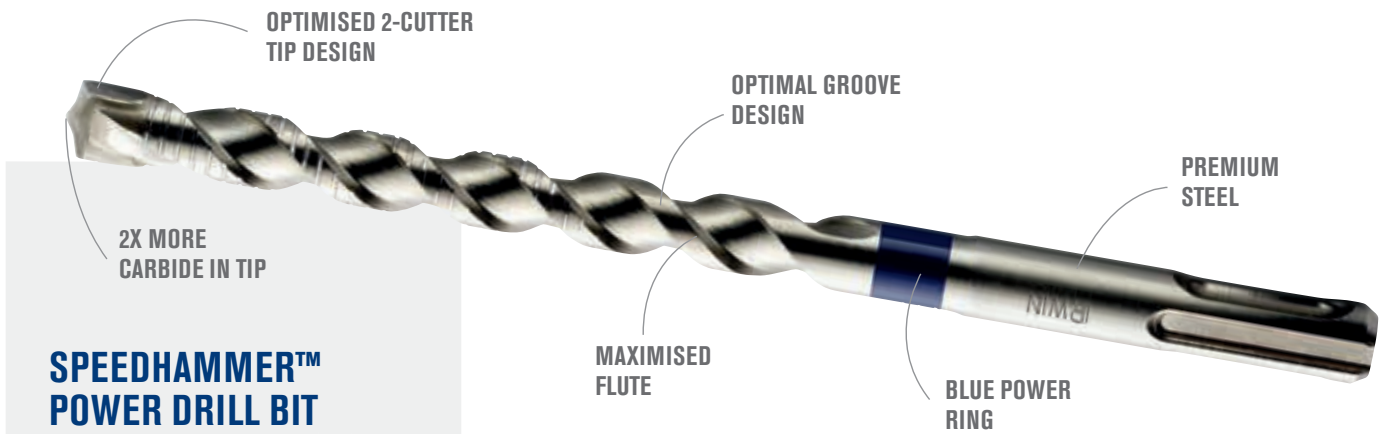

SPEEDHAMMER™ POWER DRILL BIT



2X LONGER LIFE*

- 1. 2X MORE CARBIDE IN TIP**
For 2X longer drilling life* even in rebar-reinforced concrete
- 2. OPTIMISED 2-CUTTER TIP DESIGN**
For faster drilling, especially through rebar at high speed
- 3. MAXIMISED FLUTE**
For faster, more efficient dust and debris removal
- 4. PREMIUM STEEL**
Provides improved core strength for maximum durability and extended life
- 5. BLUE POWER RING**
For easier identification in the toolbox
- 6. OPTIMAL GROOVE DESIGN**
Minimises friction for increased speed and longer life

APPLICATION:

Compatible with all hammer drilling machines with SDS-plus holder. Optimised for fast, continuous drilling, even through reinforced concrete, delivering superior performance and 2X longer life*.

DRILLING RECOMMENDATION:

When using drill bits with length over 400mm, pre-drill at least 150mm deep with a shorter drill bit of the same diameter.

SPEEDHAMMER™ Power drill bits have the certification of Prüfgemeinschaft Mauerbohrer e.V. (PGM).

BENEFITS OF PGM MARKED DRILL BITS:

- Strict tolerance limits for the diameter and the symmetry of the carbide tip ensuring the exactness of the drill hole.
- Secure anchoring and fixing.
- Constant quality assurance.
- Safety and confidence in the product.



Adherence to these criteria is constantly controlled by PGM, making the tool safe and trustworthy for the end user as well as the distributor.

* vs traditional masonry bits

SPEEDHAMMER™ POWER DRILL BITS

**SPEED
POWER
HAMMER™**



**ALSO
AVAILABLE
IN SETS
SEE PAGE 133**

10507143

| ITEM NO. | DIAMETER mm | WORKING LENGTH mm | TOTAL LENGTH mm | PIECE PER PACK | EAN | MASTER PACK | SHELF PACK |
|----------|----------------|----------------------|--------------------|-------------------|---------------|-------------|------------|
| 10507124 | 5.0 | 50 | 110 | 1 | 5706915071245 | 200 | 10 |
| 10507125 | 5.0 | 100 | 160 | 1 | 5706915071252 | 200 | 10 |
| 10507126 | 6.0 | 50 | 110 | 1 | 5706915071269 | 200 | 10 |
| 10507127 | 6.0 | 100 | 160 | 1 | 5706915071276 | 200 | 10 |
| 10507128 | 6.0 | 150 | 210 | 1 | 5706915071283 | 200 | 10 |
| 10507129 | 6.0 | 200 | 260 | 1 | 5706915071290 | 200 | 10 |
| 10507131 | 6.5 | 100 | 160 | 1 | 5706915071313 | 200 | 10 |
| 10507132 | 6.5 | 150 | 210 | 1 | 5706915071320 | 100 | 10 |
| 10507133 | 6.5 | 200 | 260 | 1 | 5706915071337 | 100 | 10 |
| 10507134 | 7.0 | 110 | 160 | 1 | 5706915071344 | 200 | 10 |
| 10507135 | 7.0 | 150 | 210 | 1 | 5706915071351 | 100 | 10 |
| 10507136 | 8.0 | 50 | 110 | 1 | 5706915071368 | 200 | 10 |
| 10507137 | 8.0 | 100 | 160 | 1 | 5706915071375 | 200 | 10 |
| 10507138 | 8.0 | 150 | 210 | 1 | 5706915071382 | 100 | 10 |
| 10507139 | 8.0 | 200 | 260 | 1 | 5706915071399 | 100 | 10 |
| 10507140 | 8.0 | 240 | 300 | 1 | 5706915071405 | 100 | 10 |
| 10507142 | 10.0 | 50 | 110 | 1 | 5706915071429 | 200 | 10 |
| 10507143 | 10.0 | 100 | 160 | 1 | 5706915071436 | 200 | 10 |
| 10507144 | 10.0 | 150 | 210 | 1 | 5706915071443 | 100 | 10 |
| 10507145 | 10.0 | 200 | 260 | 1 | 5706915071450 | 100 | 10 |
| 10507146 | 10.0 | 240 | 300 | 1 | 5706915071467 | 100 | 10 |
| 10507147 | 10.0 | 400 | 460 | 1 | 5706915071474 | 100 | 1 |
| 10507148 | 12.0 | 100 | 160 | 1 | 5706915071481 | 100 | 10 |
| 10507149 | 12.0 | 150 | 210 | 1 | 5706915071498 | 100 | 10 |
| 10507150 | 12.0 | 200 | 260 | 1 | 5706915071504 | 100 | 10 |
| 10507151 | 12.0 | 240 | 300 | 1 | 5706915071511 | 50 | 10 |
| 10507152 | 12.0 | 400 | 460 | 1 | 5706915071528 | 50 | 1 |
| 10507153 | 14.0 | 100 | 160 | 1 | 5706915071535 | 100 | 10 |
| 10507154 | 14.0 | 150 | 210 | 1 | 5706915071542 | 50 | 10 |
| 10507156 | 14.0 | 240 | 300 | 1 | 5706915071566 | 50 | 10 |
| 10507157 | 14.0 | 400 | 460 | 1 | 5706915071573 | 20 | 1 |
| 10507159 | 16.0 | 150 | 210 | 1 | 5706915071597 | 50 | 1 |
| 10507160 | 16.0 | 240 | 300 | 1 | 5706915071603 | 40 | 1 |
| 10507161 | 16.0 | 400 | 460 | 1 | 5706915071610 | 20 | 1 |
| 10507163 | 18.0 | 240 | 300 | 1 | 5706915071634 | 40 | 1 |
| 10507164 | 18.0 | 400 | 460 | 1 | 5706915071641 | 20 | 1 |
| 10507166 | 20.0 | 240 | 300 | 1 | 5706915071665 | 40 | 1 |
| 10507167 | 20.0 | 400 | 460 | 1 | 5706915071672 | 20 | 1 |

SPEEDHAMMER™ PLUS

FASTEST IRWIN® HAMMER DRILL BIT EVER

Set the pace with SPEEDHAMMER™ Plus. With 28% greater flute capacity, the innovative design goes straight in and straight out. It removes dust and debris really fast. And it's particularly effective in uncured concrete due to clog-free performance.

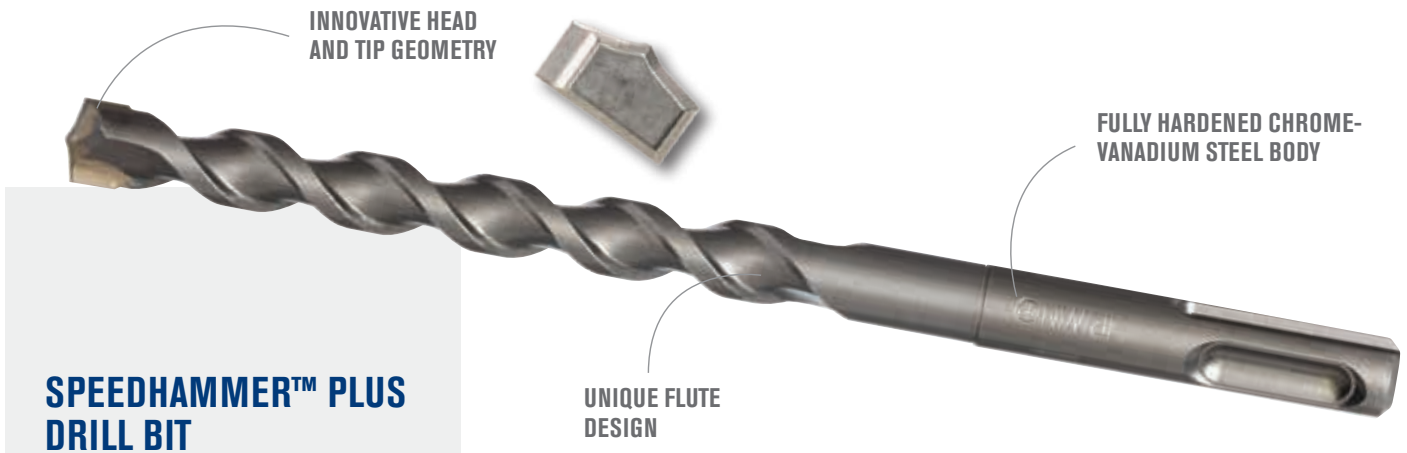

SPEEDHAMMER™ PLUS DRILL BIT



20% FASTER*

1. INNOVATIVE HEAD AND TIP GEOMETRY

25% thicker carbide tip improves strength and durability. Aggressive concave cutting angles increase drilling speed by up to 20%. Extra short drill bit head clears drilling dust directly into the flute, reducing the risk of clogging. Self-centering point prevents walking

2. UNIQUE FLUTE DESIGN

New extra deep, asymmetrical flute design provides faster dust removal and increases drilling speed

3. FULLY HARDENED CHROME-VANADIUM STEEL BODY

Resulting in maximum rupture strength and longer life



2-Cutter Head



4-Cutter Head

APPLICATION:

Compatible with all hammer drilling machines with SDS-plus holder. Designed for drilling in concrete, masonry, brick, block, and granite.

DRILLING RECOMMENDATION:

When using drill bits with length over 400mm, pre-drill at least 150mm deep with a shorter drill bit of the same diameter.

SPEEDHAMMER™ Plus drill bits have the certification of Prüfgemeinschaft Mauerbohrer e.V. (PGM).

BENEFITS OF PGM MARKED DRILL BITS:

- Strict tolerance limits for the diameter and the symmetry of the carbide tip ensuring the exactness of the drill hole.
- Secure anchoring and fixing.
- Constant quality assurance.
- Safety and confidence in the product.



Adherence to these criteria is constantly controlled by PGM, making the tool safe and trustworthy for the end user as well as the distributor.

* Up to 20% faster drilling vs. competitor products due to tip geometry and innovative flute design.

SPEEDHAMMER™ PLUS DRILL BITS

**SPEED
PLUS
HAMMER™**



10501979

| ITEM NO. | DIAMETER mm | WORKING LENGTH mm | TOTAL LENGTH mm | PIECE PER PACK | EAN | MASTER PACK | SHELF PACK |
|----------|----------------|----------------------|--------------------|-------------------|---------------|-------------|------------|
| 10501941 | 3.0 | 50 | 110 | 1 | 5709131203599 | 200 | 10 |
| 10507574 | 3.0 | 80 | 140 | 1 | 5706915075748 | 200 | 10 |
| 10501942 | 3.5 | 50 | 110 | 1 | 5709131061656 | 200 | 10 |
| 10507575 | 3.5 | 80 | 140 | 1 | 5706915075755 | 100 | 10 |
| 10501943 | 4.0 | 50 | 110 | 1 | 5709131019282 | 200 | 10 |
| 10501944 | 4.0 | 100 | 160 | 1 | 5709131019350 | 200 | 10 |
| 10503844 | 4.5 | 100 | 160 | 1 | 734442175582 | 200 | 10 |
| 10501945 | 5.0 | 50 | 110 | 1 | 5709131019466 | 200 | 10 |
| 10501946 | 5.0 | 100 | 160 | 1 | 5709131019800 | 200 | 10 |
| 10501947 | 5.0 | 150 | 210 | 1 | 5709131236962 | 100 | 10 |
| 10501948 | 5.0 | 200 | 260 | 1 | 5709131204237 | 100 | 10 |
| 10501949 | 5.5 | 50 | 110 | 1 | 5709131020011 | 200 | 10 |
| 10501950 | 5.5 | 100 | 160 | 1 | 5709131020233 | 200 | 10 |
| 10501951 | 5.5 | 150 | 210 | 1 | 5709131020363 | 100 | 10 |
| 10501952 | 5.5 | 200 | 260 | 1 | 5709131281030 | 100 | 10 |
| 10501953 | 5.5 | 240 | 300 | 1 | 5709131236986 | 100 | 10 |
| 10501954 | 6.0 | 50 | 110 | 1 | 5709131020400 | 200 | 10 |
| 10501955 | 6.0 | 100 | 160 | 1 | 5709131020769 | 200 | 10 |
| 10501956 | 6.0 | 150 | 210 | 1 | 5709131021070 | 100 | 10 |
| 10501957 | 6.0 | 200 | 260 | 1 | 5709131021124 | 100 | 10 |
| 10501958 | 6.0 | 240 | 300 | 1 | 5709131236948 | 100 | 10 |
| 10501959 | 6.0 | 400 | 460 | 1 | 5709131021162 | 50 | 10 |
| 10501960 | 6.5 | 50 | 110 | 1 | 5709131021186 | 200 | 10 |
| 10501961 | 6.5 | 100 | 160 | 1 | 5709131021353 | 200 | 10 |
| 10501962 | 6.5 | 150 | 210 | 1 | 5709131021537 | 100 | 10 |
| 10501963 | 6.5 | 200 | 260 | 1 | 5709131021544 | 100 | 10 |
| 10501964 | 7.0 | 50 | 110 | 1 | 5709131021582 | 200 | 10 |
| 10501965 | 7.0 | 100 | 160 | 1 | 5709131021704 | 200 | 10 |
| 10501966 | 7.0 | 150 | 210 | 1 | 5709131021919 | 100 | 10 |
| 10501967 | 7.0 | 340 | 400 | 1 | 5709131228929 | 50 | 10 |
| 10501968 | 8.0 | 50 | 110 | 1 | 5709131021971 | 200 | 10 |
| 10501969 | 8.0 | 100 | 160 | 1 | 5709131022305 | 200 | 10 |
| 10501970 | 8.0 | 150 | 210 | 1 | 5709131022701 | 100 | 10 |
| 10501971 | 8.0 | 200 | 260 | 1 | 5709131022947 | 100 | 10 |
| 10501972 | 8.0 | 240 | 300 | 1 | 5709131023029 | 100 | 10 |
| 10501973 | 8.0 | 400 | 460 | 1 | 5709131023142 | 50 | 10 |
| 10501974 | 8.0 | 540 | 600 | 1 | 5709131023227 | 50 | 1 |
| 10501975 | 9.0 | 100 | 160 | 1 | 5709131023364 | 200 | 10 |
| 10501976 | 9.0 | 150 | 210 | 1 | 5709131023449 | 100 | 10 |
| 10501978 | 10.0 | 50 | 110 | 1 | 5709131023524 | 200 | 10 |
| 10501979 | 10.0 | 100 | 160 | 1 | 5709131023722 | 200 | 10 |
| 10501980 | 10.0 | 150 | 210 | 1 | 5709131024095 | 100 | 10 |
| 10501981 | 10.0 | 200 | 260 | 1 | 5709131024378 | 100 | 10 |
| 10501982 | 10.0 | 240 | 300 | 1 | 5709131024484 | 100 | 10 |
| 10501984 | 10.0 | 400 | 460 | 1 | 5709131024620 | 50 | 10 |
| 10501985 | 10.0 | 540 | 600 | 1 | 5709131024750 | 50 | 1 |
| 10501986 | 10.0 | 940 | 1000 | 1 | 5709131135418 | 20 | 1 |
| 10501987 | 11.0 | 100 | 160 | 1 | 5709131024866 | 100 | 10 |
| 10501988 | 11.0 | 200 | 260 | 1 | 5709131025047 | 50 | 10 |
| 10501989 | 11.0 | 240 | 300 | 1 | 5709131025061 | 50 | 10 |
| 10501991 | 12.0 | 100 | 160 | 1 | 5709131025153 | 100 | 10 |
| 10501992 | 12.0 | 150 | 210 | 1 | 5709131025498 | 100 | 10 |
| 10501993 | 12.0 | 170 | 230 | 1 | 5709131025610 | 100 | 10 |
| 10501994 | 12.0 | 200 | 260 | 1 | 5709131025689 | 100 | 10 |
| 10501995 | 12.0 | 240 | 300 | 1 | 5709131025771 | 50 | 10 |
| 10501996 | 12.0 | 400 | 460 | 1 | 5709131025917 | 50 | 10 |
| 10501997 | 12.0 | 540 | 600 | 1 | 5709131026044 | 20 | 1 |
| 10501998 | 12.0 | 740 | 800 | 1 | 5709131026105 | 20 | 1 |
| 10501999 | 12.0 | 940 | 1000 | 1 | 5709131026112 | 20 | 1 |
| 10502000 | 13.0 | 100 | 160 | 1 | 5709131026280 | 100 | 10 |
| 10502002 | 13.0 | 240 | 300 | 1 | 5709131026488 | 50 | 10 |
| 10502004 | 14.0 | 100 | 160 | 1 | 5709131026624 | 100 | 10 |
| 10502005 | 14.0 | 150 | 210 | 1 | 5709131026778 | 50 | 1 |
| 10502006 | 14.0 | 170 | 230 | 1 | 5709131026846 | 50 | 1 |
| 10502007 | 14.0 | 200 | 260 | 1 | 5709131026907 | 50 | 1 |

MASONRY DRILLING

SPEEDHAMMER™ PLUS DRILL BITS

| ITEM NO. | DIAMETER mm | WORKING LENGTH mm | TOTAL LENGTH mm | PIECE PER PACK | EAN | MASTER PACK | SHELF PACK |
|----------|----------------|----------------------|--------------------|-------------------|---------------|-------------|------------|
| 10502008 | 14.0 | 240 | 300 | 1 | 5709131026983 | 50 | 1 |
| 10502010 | 14.0 | 400 | 460 | 1 | 5709131027058 | 20 | 1 |
| 10502011 | 14.0 | 540 | 600 | 1 | 5709131027188 | 20 | 1 |
| 10502012 | 14.0 | 940 | 1000 | 1 | 5709131137610 | 20 | 1 |
| 10502013 | 15.0 | 100 | 160 | 1 | 5709131027331 | 100 | 1 |
| 10502014 | 15.0 | 170 | 230 | 1 | 5709131027492 | 50 | 1 |
| 10502015 | 15.0 | 200 | 260 | 1 | 5709131027539 | 50 | 1 |
| 10502016 | 15.0 | 240 | 300 | 1 | 5709131027584 | 40 | 1 |
| 10502017 | 16.0 | 100 | 160 | 1 | 5709131027713 | 100 | 1 |
| 10502018 | 16.0 | 150 | 210 | 1 | 5709131027829 | 50 | 1 |
| 10502019 | 16.0 | 170 | 230 | 1 | 5709131027959 | 50 | 1 |
| 10502020 | 16.0 | 240 | 300 | 1 | 5709131028055 | 40 | 1 |
| 10502021 | 16.0 | 400 | 460 | 1 | 5709131028154 | 20 | 1 |
| 10502022 | 16.0 | 540 | 600 | 1 | 5709131028314 | 20 | 1 |
| 10502023 | 16.0 | 740 | 800 | 1 | 5709131028383 | 20 | 1 |
| 10502024 | 16.0 | 940 | 1000 | 1 | 5709131028413 | 10 | 1 |
| 10502025 | 17.0 | 150 | 210 | 1 | 5709131028475 | 50 | 1 |
| 10502027 | 18.0 | 150 | 210 | 1 | 5709131028635 | 50 | 1 |
| 10502028 | 18.0 | 240 | 300 | 1 | 5709131028857 | 40 | 1 |
| 10502029 | 18.0 | 400 | 460 | 1 | 5709131028925 | 20 | 1 |
| 10502030 | 18.0 | 540 | 600 | 1 | 5709131029038 | 20 | 1 |
| 10502031 | 18.0 | 940 | 1000 | 1 | 5709131096290 | 10 | 1 |
| 10502033 | 19.0 | 240 | 300 | 1 | 5709131029205 | 40 | 1 |
| 10502035 | 19.0 | 400 | 460 | 1 | 5709131029267 | 20 | 1 |
| 10502036 | 20.0 | 150 | 210 | 1 | 5709131029373 | 50 | 1 |
| 10502038 | 20.0 | 240 | 300 | 1 | 5709131029595 | 40 | 1 |
| 10502040 | 20.0 | 400 | 460 | 1 | 5709131029670 | 20 | 1 |
| 10502041 | 20.0 | 540 | 600 | 1 | 5709131029823 | 10 | 1 |
| 10502042 | 20.0 | 940 | 1000 | 1 | 5709131097129 | 10 | 1 |
| 10502043 | 22.0 | 200 | 260 | 1 | 5709131029939 | 25 | 1 |
| 10502044 | 22.0 | 240 | 300 | 1 | 5709131030003 | 40 | 1 |
| 10502046 | 22.0 | 400 | 460 | 1 | 5709131030126 | 10 | 1 |
| 10502047 | 22.0 | 540 | 600 | 1 | 5709131030263 | 10 | 1 |
| 10502048 | 22.0 | 940 | 1000 | 1 | 5709131097594 | 10 | 1 |
| 10502049 | 24.0 | 200 | 260 | 1 | 5709131030331 | 10 | 1 |
| 10502050 | 24.0 | 240 | 300 | 1 | 5709131030386 | 20 | 1 |
| 10502052 | 24.0 | 400 | 460 | 1 | 5709131030478 | 10 | 1 |
| 10502053 | 25.0 | 200 | 260 | 1 | 5709131030584 | 10 | 1 |
| 10502054 | 25.0 | 240 | 300 | 1 | 5709131030638 | 20 | 1 |
| 10502056 | 25.0 | 400 | 460 | 1 | 5709131030720 | 10 | 1 |
| 10502057 | 25.0 | 550 | 600 | 1 | 5709131258483 | 5 | 1 |
| 10502059 | 26.0 | 240 | 300 | 1 | 5709131030898 | 20 | 1 |
| 10502060 | 26.0 | 400 | 460 | 1 | 5709131030942 | 10 | 1 |
| 10502061 | 26.0 | 540 | 600 | 1 | 5709131128397 | 10 | 1 |



SPEEDHAMMER™ PLUS DRILL BITS - 4 CUTTING EDGES

| ITEM NO. | DIAMETER mm | WORKING LENGTH mm | TOTAL LENGTH mm | PIECE PER PACK | EAN | MASTER PACK | SHELF PACK |
|----------|----------------|----------------------|--------------------|-------------------|---------------|-------------|------------|
| 10502069 | 28.0 | 400 | 450 | 1 | 5709131184553 | 5 | 1 |
| 10502070 | 30.0 | 400 | 450 | 1 | 5709131184577 | 3 | 1 |



SPEEDHAMMER™ PLUS DRILL BITS - BULK PACK

**SPEED
PLUS
HAMMER™**



10502085

| ITEM NO. | DIAMETER mm | WORKING LENGTH mm | TOTAL LENGTH mm | PIECE PER PACK | EAN | MASTER PACK | SHELF PACK |
|-----------------------|----------------|----------------------|--------------------|-------------------|---------------|-------------|------------|
| 5-PIECE PACKS | | | | | | | |
| 10503603 | 5.0 | 50 | 110 | 5 | 5709131286172 | 1 | 1 |
| 10503605 | 6.0 | 50 | 110 | 5 | 5709131286202 | 1 | 1 |
| 10503606 | 6.0 | 100 | 160 | 5 | 5709131285991 | 1 | 1 |
| 10503607 | 6.0 | 150 | 210 | 5 | 5709131286028 | 1 | 1 |
| 10503609 | 8.0 | 50 | 110 | 5 | 5709131280231 | 1 | 1 |
| 10503610 | 8.0 | 100 | 160 | 5 | 5709131286110 | 1 | 1 |
| 10503611 | 8.0 | 150 | 210 | 5 | 5709131286080 | 1 | 1 |
| 10503612 | 10.0 | 100 | 160 | 5 | 5709131286141 | 1 | 1 |
| 10503613 | 10.0 | 150 | 210 | 5 | 5709131286325 | 1 | 1 |
| 10-PIECE PACKS | | | | | | | |
| 10502071 | 5.0 | 50 | 110 | 10 | 5709131176206 | 30 | 1 |
| 10502072 | 5.0 | 100 | 160 | 10 | 5709131176220 | 30 | 1 |
| 10502073 | 5.5 | 50 | 110 | 10 | 5709131176244 | 30 | 1 |
| 10502074 | 5.5 | 100 | 160 | 10 | 5709131176268 | 30 | 1 |
| 10502075 | 6.0 | 50 | 110 | 10 | 5709131176282 | 30 | 1 |
| 10502076 | 6.0 | 100 | 160 | 10 | 5709131176305 | 1 | 1 |
| 10502077 | 6.0 | 150 | 210 | 10 | 5709131228943 | 30 | 1 |
| 10502080 | 6.5 | 150 | 210 | 10 | 5709131230823 | 20 | 1 |
| 10503845 | 7.0 | 100 | 160 | 10 | 734442175827 | 20 | 1 |
| 10502082 | 8.0 | 100 | 160 | 10 | 5709131176404 | 30 | 1 |
| 10502083 | 8.0 | 150 | 210 | 10 | 5709131176428 | 30 | 1 |
| 10502084 | 10.0 | 50 | 110 | 10 | 5709131176442 | 20 | 1 |
| 10502085 | 10.0 | 100 | 160 | 10 | 5709131253341 | 30 | 1 |
| 10502086 | 10.0 | 150 | 210 | 10 | 5709131176480 | 25 | 1 |
| 10502087 | 12.0 | 100 | 160 | 10 | 5709131176503 | 25 | 1 |
| 10502088 | 12.0 | 150 | 210 | 10 | 5709131230199 | 25 | 1 |

SPEEDHAMMER™ MAX

DESIGNED FOR TOUGHER TASKS

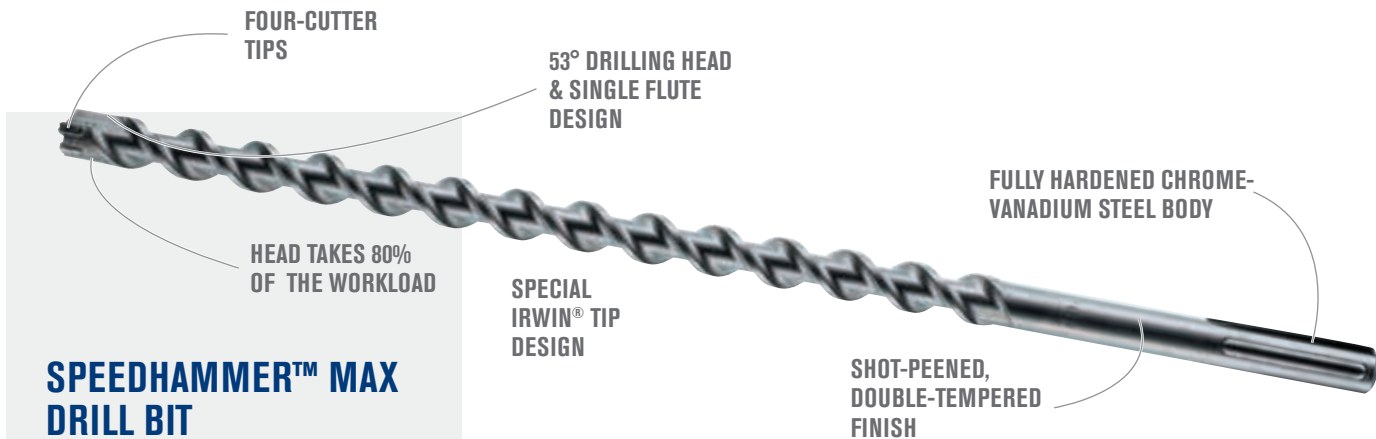

SPEEDHAMMER™ MAX DRILL BIT



- 1. SPECIAL IRWIN® TIP DESIGN**
Enhances dust removal and produces symmetrical holes
- 2. HEAD TAKES 80% OF THE WORKLOAD**
Ensuring higher durability, speed and steel reinforced bar (Rebar) drilling performance
- 3. 53° DRILLING HEAD & SINGLE FLUTE DESIGN**
Means more aggressive cutting and 30% faster dust removal for overall faster drilling
- 4. FOUR-CUTTER TIPS**
For less vibration, faster drilling, rounder holes and better anchoring
- 5. FULLY HARDENED CHROME-VANADIUM STEEL BODY**
For maximum strength and life
- 6. SHOT-PEENED, DOUBLE-TEMPERED FINISH**
For increased wear resistance and extended life
Shank fits in all SDS Max Hammer Machines

SPEEDHAMMER™ MAX DRILL BITS 2 CUTTING EDGES

| ITEM NO. | DIAMETER mm | WORKING LENGTH mm | TOTAL LENGTH mm | PIECE PER PACK | EAN | MASTER PACK | SHELF PACK |
|----------|-------------|-------------------|-----------------|----------------|---------------|-------------|------------|
| 10502092 | 12.0 | 200 | 340 | 1 | 5709131233756 | 25 | 1 |
| 10502093 | 12.0 | 400 | 540 | 1 | 5709131233770 | 10 | 1 |
| 10502094 | 12.0 | 550 | 690 | 1 | 5709131233794 | 10 | 1 |
| 10502095 | 14.0 | 200 | 340 | 1 | 5709131233817 | 25 | 1 |
| 10502096 | 14.0 | 400 | 540 | 1 | 5709131233831 | 10 | 1 |
| 10502097 | 15.0 | 200 | 340 | 1 | 5709131233855 | 25 | 1 |
| 10502098 | 15.0 | 400 | 540 | 1 | 5709131233879 | 10 | 1 |



SPEEDHAMMER™ MAX DRILL BITS 4 CUTTING EDGES



10502113

| ITEM NO. | DIAMETER mm | WORKING LENGTH mm | TOTAL LENGTH mm | PIECE PER PACK | EAN | MASTER PACK | SHELF PACK |
|----------|----------------|----------------------|--------------------|-------------------|---------------|-------------|------------|
| 10502099 | 16.0 | 200 | 340 | 1 | 5709131233893 | 25 | 1 |
| 10502100 | 16.0 | 400 | 540 | 1 | 5709131233916 | 10 | 1 |
| 10502101 | 18.0 | 200 | 340 | 1 | 5709131233930 | 25 | 1 |
| 10502102 | 18.0 | 400 | 540 | 1 | 5709131233954 | 10 | 1 |
| 10502103 | 20.0 | 200 | 320 | 1 | 5709131233978 | 25 | 1 |
| 10502104 | 20.0 | 400 | 520 | 1 | 5709131233992 | 10 | 1 |
| 10502105 | 20.0 | 800 | 920 | 1 | 5709131234012 | 5 | 1 |
| 10502106 | 22.0 | 200 | 320 | 1 | 5709131234036 | 25 | 1 |
| 10502107 | 22.0 | 400 | 520 | 1 | 5709131234050 | 10 | 1 |
| 10502108 | 22.0 | 800 | 920 | 1 | 5709131234074 | 5 | 1 |
| 10502109 | 24.0 | 200 | 320 | 1 | 5709131234098 | 10 | 1 |
| 10502110 | 24.0 | 400 | 520 | 1 | 5709131234111 | 5 | 1 |
| 10502111 | 25.0 | 200 | 320 | 1 | 5709131234135 | 10 | 1 |
| 10502112 | 25.0 | 400 | 520 | 1 | 5709131234159 | 5 | 1 |
| 10502113 | 25.0 | 800 | 920 | 1 | 5709131234173 | 5 | 1 |
| 10502115 | 28.0 | 250 | 370 | 1 | 5709131234197 | 5 | 1 |
| 10502116 | 28.0 | 450 | 570 | 1 | 5709131234210 | 5 | 1 |
| 10502117 | 28.0 | 550 | 670 | 1 | 5709131234234 | 5 | 1 |
| 10502118 | 30.0 | 250 | 370 | 1 | 5709131234241 | 3 | 1 |
| 10502119 | 30.0 | 450 | 570 | 1 | 5709131234272 | 3 | 1 |
| 10502120 | 32.0 | 250 | 370 | 1 | 5709131234296 | 3 | 1 |
| 10502121 | 32.0 | 450 | 570 | 1 | 5709131234319 | 3 | 1 |
| 10502122 | 32.0 | 800 | 920 | 1 | 5709131234333 | 3 | 1 |
| 10502123 | 35.0 | 250 | 370 | 1 | 5709131234340 | 3 | 1 |
| 10502124 | 35.0 | 450 | 570 | 1 | 5709131234364 | 3 | 1 |
| 10502125 | 35.0 | 550 | 670 | 1 | 5709131234388 | 2 | 1 |
| 10502126 | 38.0 | 250 | 370 | 1 | 5709131234395 | 2 | 1 |
| 10502127 | 38.0 | 450 | 570 | 1 | 5709131234401 | 2 | 1 |
| 10502128 | 40.0 | 250 | 370 | 1 | 5709131234418 | 2 | 1 |
| 10502129 | 40.0 | 430 | 570 | 1 | 5709131234425 | 2 | 1 |
| 10502130 | 40.0 | 780 | 920 | 1 | 5709131234647 | 2 | 1 |

DEMOLITION CHISELS

POINTED CHISEL



For general chiselling and breaking work in brick, concrete and loose stone (eg: when laying cables)

FLAT CHISEL



For general chiselling and breaking work in brick, concrete and loose stone (eg: when laying cables)

SPADE CHISEL



For removing large quantities of material

GOUGE CHISEL



For cutting narrow channels into concrete

TCT POINTING CHISEL



For the removal of pointing in brickwork

CRANKED TILE CHISEL



For easy removal of tiles

ALSO AVAILABLE IN SETS
SEE PAGE 133

SPEEDHAMMER™ PLUS DEMOLITION CHISELS

| ITEM NO. | DESCRIPTION | EAN | MASTER PACK | SHELF PACK |
|----------|--------------------------------|---------------|-------------|------------|
| 10502194 | Pointed Chisel 250mm | 5709131281979 | - | 1 |
| 10502195 | Flat Chisel 20 x 250mm | 5709131281986 | - | 1 |
| 10502196 | Spade Chisel 40 x 250mm | 5709131281993 | - | 1 |
| 10502197 | Gouge Chisel 22 x 250mm | 5709131282006 | - | 1 |
| 10502198 | TCT Pointing Chisel 32 x 125mm | 5709131285595 | - | 1 |
| 10502200 | TCT Pointing Chisel 32 x 200mm | 5709131285601 | - | 1 |
| 10503643 | Cranked Tile Chisel 40 x 250mm | 5706915001273 | - | 1 |

DESIGNED FOR A WIDE RANGE OF APPLICATIONS for both SDS Plus and SDS Max hammer drills: breaking through or breaking up concrete, light demolition work and chasing of channels for pipes and electrical conduit
IDEAL FOR DRILLING in concrete and masonry
HIGH-QUALITY ALLOYED STEEL is precision hardened for optimum performance and life

SPEEDHAMMER™ MAX DEMOLITION CHISELS

| ITEM NO. | DESCRIPTION | EAN | MASTER PACK | SHELF PACK |
|----------|--------------------------------|---------------|-------------|------------|
| 10502184 | Pointed Chisel 280mm | 5709131281870 | - | 1 |
| 10502185 | Pointed Chisel 400mm | 5709131281887 | - | 1 |
| 10502186 | Pointed Chisel 600mm | 5709131281894 | - | 1 |
| 10502187 | Flat Chisel 25 x 280mm | 5709131281900 | - | 1 |
| 10502188 | Flat Chisel 25 x 400mm | 5709131281917 | - | 1 |
| 10502189 | Flat Chisel 25 x 600mm | 5709131281924 | - | 1 |
| 10502190 | Spade Chisel 115 x 350mm | 5709131281931 | - | 1 |
| 10502191 | Spade Chisel 50 x 400mm | 5709131281948 | - | 1 |
| 10502192 | Spade Chisel 80 x 300mm | 5709131281955 | - | 1 |
| 10503644 | Cranked Tile Chisel 50 x 400mm | 5706915001297 | - | 1 |



HEAVY-DUTY CORE DRILLS



SPEEDHAMMER™ MAX DRILL BITS 2 CUTTING EDGES

| | ITEM NO. | DESCRIPTION | HOLE DIAMETER mm | LENGTH mm | PIECE PER PACK | EAN | MASTER PACK | SHELF PACK |
|----------------------------------------------------------------------------------------------------------------------------------------------------------------------------------------------------------|----------|----------------------------|---------------------|--------------|-------------------|---------------|-------------|------------|
| DESIGNED FOR DRILLING LARGE DIAMETERS (35-150mm) into concrete, granite and other very hard materials FOR EASY PILOT DRILL REMOVAL push the drift key into the slot of the drill rod | 10507198 | Drill Rod 180mm SPDHMAX | - | 180 | 1 | 5706915071986 | 50 | 1 |
| | 10507199 | Drill Rod 450mm SPDHMAX | - | 450 | 1 | 5706915071993 | 20 | 1 |
| | 10507200 | Drill Rod 115mm SPDHPLUS | - | 115 | 1 | 5706915072006 | 80 | 1 |
| | 10507211 | HD Core Drill 40mm | 40 | 100 | 1 | 5706915072112 | 20 | 1 |
| | 10507212 | HD Core Drill 45mm | 45 | 100 | 1 | 5706915072129 | 20 | 1 |
| | 10507213 | HD Core Drill 50mm | 50 | 100 | 1 | 5706915072136 | 20 | 1 |
| | 10507214 | HD Core Drill 60mm | 60 | 100 | 1 | 5706915072143 | 15 | 1 |
| | 10507215 | HD Core Drill 65mm | 65 | 100 | 1 | 5706915072150 | 15 | 1 |
| | 10507216 | HD Core Drill 75mm | 75 | 100 | 1 | 5706915072167 | 8 | 1 |
| | 10507217 | HD Core Drill 80mm | 80 | 100 | 1 | 5706915072174 | 8 | 1 |
| | 10507218 | HD Core Drill 90mm | 90 | 100 | 1 | 5706915072181 | 6 | 1 |
| | 10507219 | HD Core Drill 100mm | 100 | 100 | 1 | 5706915072198 | 6 | 1 |
| | 10507220 | HD Core Drill 115mm | 115 | 100 | 1 | 5706915072204 | 4 | 1 |
| | 10507221 | HD Core Drill 125mm | 125 | 100 | 1 | 5706915072211 | 4 | 1 |
| | 10507222 | HD Core Drill 150mm | 150 | 100 | 1 | 5706915072228 | 3 | 1 |
| | 10507224 | Pilot Drill Bit 11 x 120mm | 11 | 120 | 1 | 5706915072242 | 200 | 1 |
| | 10507225 | Core Drill Drift Key | - | - | 1 | 5706915072259 | 200 | 1 |

CORDLESS MULTI DRILL BITS



ONE DRILL BIT FOR EVERY MATERIAL

The Cordless Multi drill bit is IRWIN®'s most versatile drill bit. It is designed to drill in multiple materials including brick, light concrete, dry wall, ceramic tiles, sheet metal, wood, plastic and marble. In addition to the multipurpose function, the Cordless Multi is IRWIN®'s problem solver for drilling into ceramic tiles up to a hardness grade of 9.

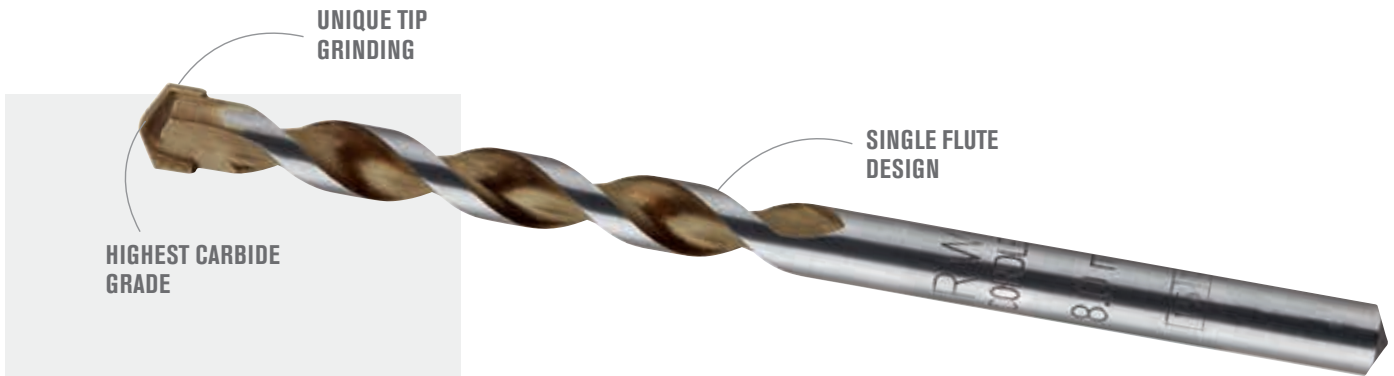

CORDLESS MULTI



1. HIGHEST CARBIDE GRADE

For fast drilling into most common materials and hardest tiles (scratch hardness 9)

2. SINGLE FLUTE DESIGN

Giving maximum space for dust removal. Up to 15% Speed advantage over competition. 10% more holes per battery charge

3. UNIQUE TIP GRINDING

Brazed carbide tip has a unique diamond ground 4-face design for excellent centering and perfect hole quality

USEFUL TIPS:

1. Drill with low RPM
2. High pressure
3. No hammer action



CORDLESS MULTI-DRILL BITS - ROTARY DRILLING ONLY

| ITEM NO. | DIAMETER mm | WORKING LENGTH mm | TOTAL LENGTH mm | SHANK DIAMETER mm | EAN | MASTER PACK | SHELF PACK |
|----------|-------------|-------------------|-----------------|-------------------|---------------|-------------|------------|
| 10501919 | 3.0 | 40 | 110 | CYL as Ø | 5709131285731 | 200 | 10 |
| 10501920 | 3.5 | 40 | 110 | CYL as Ø | 5709131285762 | 200 | 10 |
| 10501921 | 4.0 | 45 | 80 | CYL as Ø | 5709131000303 | 200 | 10 |
| 10501922 | 5.0 | 50 | 90 | CYL as Ø | 5709131000563 | 200 | 10 |
| 10501923 | 5.5 | 55 | 95 | CYL as Ø | 5709131000822 | 200 | 10 |
| 10501924 | 5.5 | 115 | 160 | CYL as Ø | 5709131055037 | 200 | 10 |
| 10501925 | 6.0 | 60 | 100 | CYL as Ø | 5709131000983 | 200 | 10 |
| 10501926 | 6.0 | 115 | 160 | CYL as Ø | 5709131001164 | 200 | 10 |
| 10501927 | 6.0 | 120 | 200 | CYL as Ø | 5709131247593 | 100 | 10 |
| 10501928 | 6.5 | 60 | 105 | CYL as Ø | 5709131001348 | 200 | 10 |
| 10501929 | 6.5 | 120 | 200 | CYL as Ø | 5709131243007 | 100 | 10 |
| 10501930 | 7.0 | 65 | 110 | CYL as Ø | 5709131001577 | 200 | 10 |
| 10501931 | 7.0 | 115 | 160 | CYL as Ø | 5709131001720 | 200 | 10 |
| 10501932 | 8.0 | 70 | 120 | CYL as Ø | 5709131001836 | 200 | 10 |
| 10501933 | 8.0 | 120 | 200 | CYL as Ø | 5709131002086 | 100 | 10 |
| 10501934 | 10.0 | 70 | 140 | CYL as Ø | 5709131002710 | 200 | 10 |
| 10501935 | 10.0 | 120 | 200 | CYL as Ø | 5709131002918 | 100 | 10 |
| 10501936 | 12.0 | 105 | 160 | CYL as Ø | 5709131003267 | 50 | 10 |
| 10501937 | 14.0 | 100 | 160 | 10 | 5709131003717 | 50 | 10 |



10501931

ALSO AVAILABLE IN SETS
SEE PAGE 134

MASONRY DRILL BITS

FASTEST AND LONGEST LASTING MASONRY DRILL BIT

MASONRY



MASONRY DRILL BITS - ROTARY PERCUSSION

IMPROVED CARBIDE TIP DESIGN ensures for durability and fast drilling in all masonry materials
AGGRESSIVE HEAD DESIGN for up to 15% speed advantage over competition
UNIQUE BRAZING PROCESS ensures a perfect bond between tip and body
SINGLE FLUTE DESIGN gives maximum space for dust removal and provides a 60% faster dust removal

20% LONGER LIFE*

ALSO AVAILABLE IN SETS
SEE PAGE 134



10501830

| ITEM NO. | DIAMETER mm | WORKING LENGTH mm | TOTAL LENGTH mm | SHANK DIAMETER mm | EAN | MASTER PACK | SHELF PACK |
|----------|-------------|-------------------|-----------------|-------------------|---------------|-------------|------------|
| 10501812 | 3.0 | 45 | 75 | CYL as Ø | 5709131000129 | 200 | 10 |
| 10501813 | 3.5 | 45 | 75 | CYL as Ø | 5709131000211 | 200 | 10 |
| 10501814 | 4.0 | 45 | 75 | CYL as Ø | 5709131055839 | 200 | 10 |
| 10501815 | 4.0 | 90 | 150 | CYL as Ø | 5709131055075 | 200 | 10 |
| 10501816 | 4.5 | 45 | 85 | CYL as Ø | 5709131000488 | 200 | 10 |
| 10501817 | 5.0 | 50 | 90 | CYL as Ø | 5709131055846 | 200 | 10 |
| 10501818 | 5.0 | 90 | 150 | CYL as Ø | 5709131000778 | 200 | 10 |
| 10501819 | 5.5 | 50 | 90 | CYL as Ø | 5709131055853 | 200 | 10 |
| 10501820 | 5.5 | 90 | 150 | CYL as Ø | 5709131000952 | 200 | 10 |
| 10501821 | 6.0 | 60 | 100 | CYL as Ø | 5709131055860 | 200 | 10 |
| 10501822 | 6.0 | 90 | 150 | CYL as Ø | 5709131055877 | 200 | 10 |
| 10501823 | 6.0 | 280 | 330 | CYL as Ø | 5709131001225 | 100 | 1 |
| 10501824 | 6.0 | 300 | 400 | CYL as Ø | 5709131001249 | 50 | 1 |
| 10501826 | 6.5 | 60 | 100 | CYL as Ø | 5709131055884 | 200 | 10 |
| 10501827 | 6.5 | 90 | 150 | CYL as Ø | 5709131001461 | 50 | 10 |
| 10501830 | 7.0 | 60 | 100 | CYL as Ø | 5709131055891 | 200 | 10 |
| 10501831 | 7.0 | 90 | 150 | CYL as Ø | 5709131055907 | 200 | 10 |
| 10501834 | 8.0 | 70 | 120 | CYL as Ø | 5709131055914 | 200 | 10 |
| 10501835 | 8.0 | 90 | 150 | CYL as Ø | 5709131002055 | 200 | 10 |
| 10501836 | 8.0 | 130 | 200 | CYL as Ø | 5709131055921 | 100 | 10 |
| 10501837 | 8.0 | 240 | 330 | CYL as Ø | 5709131002130 | 100 | 1 |
| 10501838 | 8.0 | 300 | 400 | CYL as Ø | 5709131002147 | 50 | 1 |
| 10501841 | 9.0 | 70 | 120 | CYL as Ø | 5709131002352 | 200 | 10 |
| 10501846 | 10.0 | 70 | 120 | CYL as Ø | 5709131055938 | 200 | 10 |
| 10501847 | 10.0 | 90 | 150 | CYL as Ø | 5709131002871 | 200 | 10 |
| 10501848 | 10.0 | 130 | 200 | CYL as Ø | 5709131055945 | 100 | 10 |
| 10501849 | 10.0 | 240 | 330 | CYL as Ø | 5709131002963 | 100 | 1 |
| 10501850 | 10.0 | 300 | 400 | CYL as Ø | 5709131002987 | 50 | 1 |
| 10501853 | 11.0 | 90 | 150 | CYL as Ø | 5709131003106 | 50 | 10 |
| 10501854 | 12.0 | 90 | 150 | 10 | 5709131055952 | 50 | 10 |
| 10501855 | 12.0 | 240 | 330 | 10 | 5709131003397 | 30 | 1 |
| 10501856 | 12.0 | 300 | 400 | 10 | 5709131003403 | 30 | 1 |
| 10501859 | 13.0 | 90 | 150 | 10 | 5709131003526 | 30 | 10 |
| 10501862 | 14.0 | 90 | 150 | 10 | 5709131055969 | 50 | 10 |
| 10501863 | 14.0 | 240 | 330 | 10 | 5709131003762 | 30 | 1 |
| 10501864 | 14.0 | 300 | 400 | 10 | 5709131003786 | 30 | 1 |
| 10501866 | 15.0 | 90 | 150 | 10 | 5709131003878 | 50 | 1 |
| 10501867 | 16.0 | 90 | 150 | 10 | 5709131003915 | 15 | 1 |
| 10501869 | 16.0 | 300 | 400 | 13 | 5709131003991 | 15 | 1 |
| 10501873 | 18.0 | 95 | 160 | 13 | 5709131004158 | 50 | 1 |
| 10501874 | 18.0 | 300 | 400 | 13 | 5709131004172 | 15 | 1 |
| 10501877 | 19.0 | 300 | 400 | 13 | 5709131004295 | 10 | 1 |
| 10501878 | 20.0 | 95 | 160 | 13 | 5709131004325 | 10 | 1 |
| 10501880 | 20.0 | 300 | 400 | 13 | 5709131004356 | 10 | 1 |
| 10501882 | 22.0 | 95 | 160 | 13 | 5709131004424 | 50 | 1 |
| 10501884 | 22.0 | 300 | 400 | 13 | 5709131004486 | 10 | 1 |
| 10501885 | 24.0 | 95 | 160 | 13 | 5709131004530 | 25 | 1 |
| 10501886 | 24.0 | 300 | 400 | 13 | 5709131004554 | 5 | 1 |
| 10501888 | 26.0 | 80 | 160 | 13 | 5709131004608 | 25 | 1 |

* vs traditional masonry bits

GRANITE DRILL BITS

DESIGNED FOR PERCUSSION DRILLING IN VERY HARD MATERIALS

GRANITE



GRANITE DRILL BITS - ROTARY PERCUSSION

| ITEM NO. | DIAMETER mm | WORKING LENGTH mm | TOTAL LENGTH mm | SHANK DIAMETER mm | EAN | MASTER PACK | SHELF PACK |
|----------|-------------|-------------------|-----------------|-------------------|---------------|-------------|------------|
| 10501894 | 3.0 | 40 | 70 | CYL as Ø | 5709131008095 | 200 | 10 |
| 10501895 | 3.5 | 40 | 75 | CYL as Ø | 5709131008101 | 200 | 10 |
| 10501896 | 4.0 | 45 | 80 | CYL as Ø | 5709131008118 | 200 | 10 |
| 10501897 | 5.0 | 50 | 90 | CYL as Ø | 5709131008163 | 200 | 10 |
| 10501898 | 5.0 | 115 | 160 | CYL as Ø | 5709131008187 | 200 | 10 |
| 10501899 | 5.5 | 55 | 95 | CYL as Ø | 5709131008200 | 200 | 10 |
| 10501901 | 6.0 | 60 | 100 | CYL as Ø | 5709131008231 | 200 | 10 |
| 10501902 | 6.0 | 115 | 160 | CYL as Ø | 5709131008255 | 200 | 10 |
| 10501903 | 6.5 | 60 | 105 | CYL as Ø | 5709131008293 | 200 | 10 |
| 10501905 | 7.0 | 60 | 110 | CYL as Ø | 5709131008323 | 200 | 10 |
| 10501906 | 7.0 | 115 | 160 | CYL as Ø | 5709131008347 | 200 | 10 |
| 10501907 | 8.0 | 70 | 120 | CYL as Ø | 5709131008378 | 200 | 10 |
| 10501908 | 8.0 | 130 | 200 | CYL as Ø | 5709131008392 | 100 | 10 |
| 10501910 | 9.0 | 70 | 130 | CYL as Ø | 5709131008446 | 200 | 10 |
| 10501911 | 10.0 | 70 | 140 | CYL as Ø | 5709131008460 | 200 | 10 |
| 10501912 | 10.0 | 130 | 200 | CYL as Ø | 5709131008491 | 100 | 10 |
| 10501913 | 11.0 | 105 | 160 | CYL as Ø | 5709131008545 | 50 | 10 |
| 10501914 | 12.0 | 105 | 160 | CYL as Ø | 5709131008552 | 50 | 10 |
| 10501915 | 13.0 | 100 | 160 | 10 | 5709131008606 | 50 | 10 |
| 10501916 | 14.0 | 100 | 160 | 10 | 5709131008613 | 50 | 10 |

FOR PERCUSSION DRILLING in very hard materials such as granite
EXTREMELY HARD AND WEAR RESISTANT CARBIDE guarantees up to 40% more holes compared to conventional masonry drill bits
STONE MASONS favour this product for impact drilling of natural stone like granite
SPECIAL SHAPED CUTTING EDGES mean higher durability resulting in 50% more accurately sized holes per drill bit



ALSO AVAILABLE IN SETS
SEE PAGE 134

10501901

GLASS AND TILE BITS

GLASS & TILES

FOR DRILLING GLASS, TILE AND CERAMICS

Carbide spear-point tip cuts clean, round holes with minimised chipping in glass, tile and ceramic.



USEFUL TIPS:

1. Drill with low RPM
2. High pressure
3. No hammer action
4. Not suitable for use on toughened glass or porcelain

| ITEM NO. | DESCRIPTION | EAN | MASTER PACK | SHELF PACK |
|----------|-------------------|---------------|-------------|------------|
| 10507903 | Glass & Tile 4mm | 5706915079036 | 200 | 10 |
| 10507904 | Glass & Tile 5mm | 5706915079043 | 200 | 10 |
| 10507905 | Glass & Tile 6mm | 5706915079050 | 200 | 10 |
| 10507906 | Glass & Tile 7mm | 5706915079067 | 200 | 10 |
| 10507907 | Glass & Tile 8mm | 5706915079074 | 200 | 10 |
| 10507909 | Glass & Tile 10mm | 5706915079098 | 200 | 10 |



DIAMOND DRILL BITS

DIAMOND

FOR FAST, SMOOTH CUTTING IN ALL GRADES OF HARD AND SOFT TILES



10507896

| ITEM NO. | DESCRIPTION | EAN | MASTER PACK | SHELF PACK |
|----------|------------------------|---------------|-------------|------------|
| 10507892 | Diamond Drill BIT 5mm | 5706915078923 | 60 | 1 |
| 10507893 | Diamond Drill BIT 6mm | 5706915078930 | 60 | 1 |
| 10507894 | Diamond Drill BIT 7mm | 5706915078947 | 60 | 1 |
| 10507895 | Diamond Drill BIT 8mm | 5706915078954 | 60 | 1 |
| 10507896 | Diamond Drill BIT 10mm | 5706915078961 | 60 | 1 |
| 10507897 | Diamond Drill BIT 12mm | 5706915078978 | 60 | 1 |
| 10507898 | Diamond Drill BIT 14mm | 5706915078985 | 60 | 1 |

USEFUL TIPS:

1. Drilling with water increases the lifespan of the tool.
2. Do not press strongly on the tool, let it work.
3. Make a swinging movement to allow dust evacuation.
4. Cutting speed: 2700 RPM.
5. No hammer action.



The drill needs to run before hitting the surface. To avoid sliding of the drill, start with an angle of 45°.



Once the hole has started, raise the drill gradually up to the vertical line.



Make an oscillating movement while drilling.



MORTAR RAKES

The Mortar Rake is designed to replace traditional methods of mortar removal such as powered mortar chisels and cutting discs. The rake is faster and less intrusive to surrounding brickwork and, unlike other methods, it is just as efficient for both horizontal and vertical joint clearing.

Please note that the cutters must be used together with an adaptor (10507234) and angle grinder.



| ITEM NO. | DESCRIPTION | EAN | MASTER PACK | SHELF PACK |
|----------|-------------------------------------------------------------------------|---------------|-------------|------------|
| 10507229 | 8,0 x 20/40mm, 3 cutter, (2 pcs.) | 5706915072297 | 50 | 5 |
| 10507230 | 10,0 x 20/40mm, 3 cutter (2 pcs.) | 5706915072303 | 50 | 5 |
| 10507231 | 12,0 x 20/40mm, 3 cutter, (2 pcs.) | 5706915072310 | 50 | 5 |
| 10507232 | 8,0 x 20/40mm, 4 cutter, (2 pcs.) | 5706915072327 | 50 | 5 |
| 10507233 | 10,0 x 20/40mm, 4 cutter (2 pcs.) | 5706915072334 | 50 | 5 |
| 10507234 | Adapter | 5706915072341 | 50 | 5 |
| 10502880 | Sole plate U500 | 5709131266488 | 15 | 1 |
| 10507267 | Starter kit 8mm 1 pc. sole plate, 2 pcs. 8,0mm 3 cutter - 1 pc. adaptor | 5706915072679 | 15 | 1 |
| 10507268 | Starter kit 10mm 1 pc. sole plate 2 pcs. 10mm 3 cutter - 1 pc. adaptor | 5706915072686 | 15 | 1 |

M-SYSTEM

M-SYSTEM



HOW IT WORKS

1. Push the body backwards and start drilling.
New IRWIN® Carbide Tip Design ensures an easy start on fibre cement.
2. After drilling the hole pull back the pilot drill and fix the hexagon-screw with the same tool.
3. Special spring to keep the screw in place before fixing.
No more adapters or additional power tools required for roofing applications.
For more convenient and safer work.

| ITEM NO. | DESCRIPTION | EAN | MASTER PACK | SHELF PACK |
|----------|------------------------------|---------------|-------------|------------|
| 10507590 | M-System 8 mm | 5706915075908 | 30 | 5 |
| 10502865 | M-System 11 mm | 5709131054276 | 15 | 1 |
| 10503476 | 8 mm Drill Bit for M-System | 5709131054290 | 200 | 10 |
| 10507937 | 11 mm Drill Bit for M-System | 5706915079371 | 200 | 10 |

2-IN-1 TOOL DESIGN for easy and fast fixing of fibre cement and similar roofing/panelling materials
IMPROVED CARBIDE TIP ensures easy starts
SPECIAL SPRING keeps the screw in place before fixing

IRWIN®

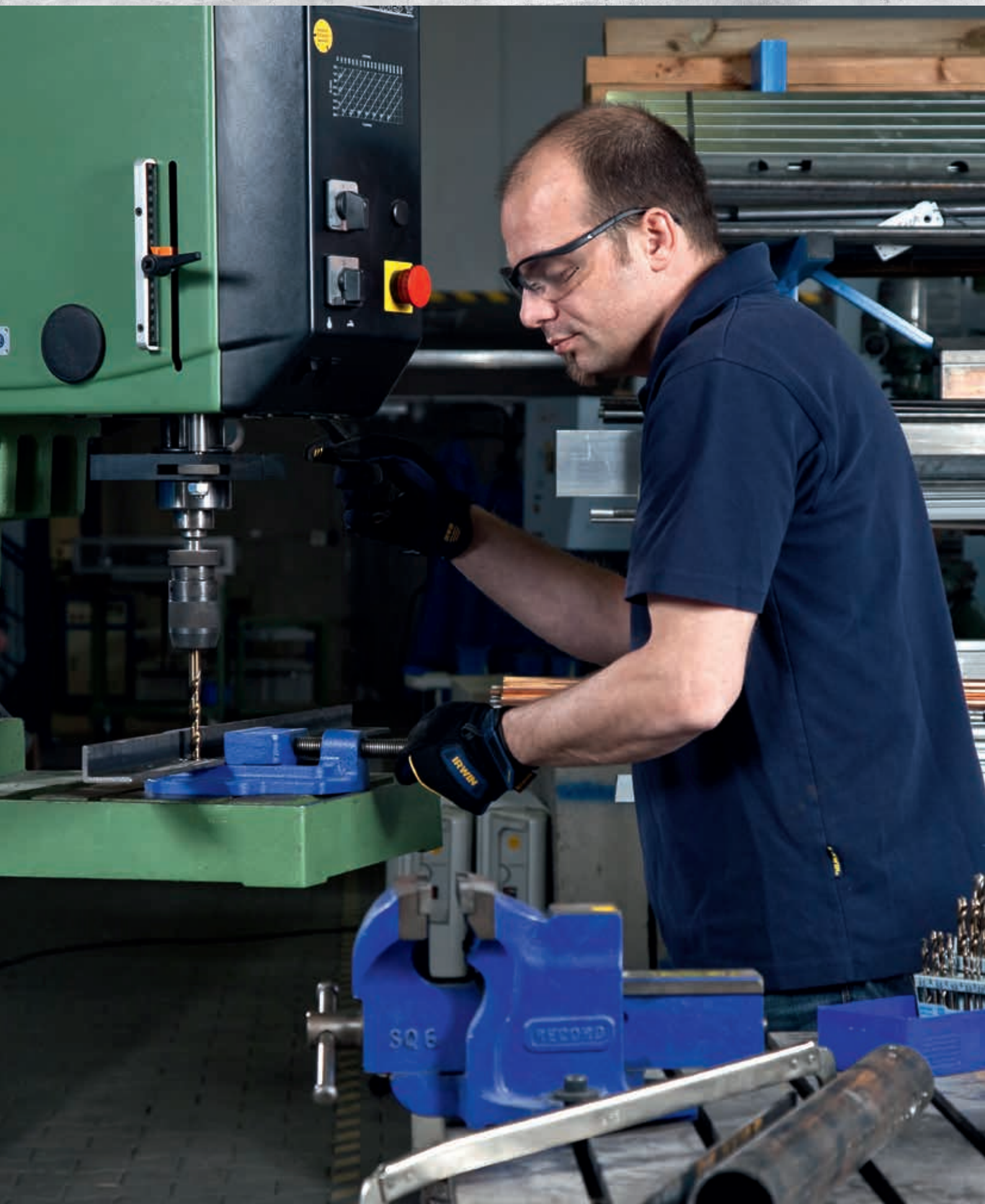

ENGINEERED FOR CONTROLLED PRECISION AND SPEED

The IRWIN® line of metal drill bits offers of a solution for every professional application. Each metal drill bit is made of high speed steel with high precision-cut point and spiral, ensuring durability and quality.

TOTAL LENGTH: The length from the point to the end of the drill bit

POINT ANGLE: The angle of the cutting edges

DRILL DIAMETER: The cutting diameter of the drill bit

SHANK LENGTH: The end of the drill bit that is secured by the drill

WORKING LENGTH: The length from the point to the end of the flutes

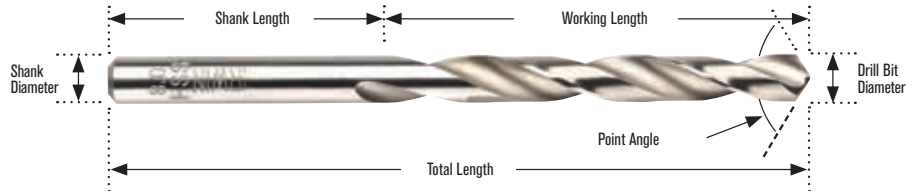

TIP GEOMETRY

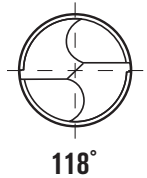

118°



118° STANDARD POINT

- For drilling in alloyed and non-alloyed steels, non-ferrous metals, cast iron and hard plastics
- Can be easily resharpened
- Requires higher feed pressure
- Best for stationary drills

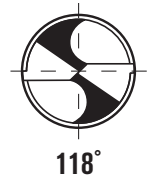

118°



118° SPLIT POINT

- For drilling in alloyed and non-alloyed steels, non-ferrous metals, cast iron and hard plastics
- Very good centering
- Requires less effort / feed pressure



135°



135° SPLIT POINT

- For drilling in high strength steel and high-alloy steels
- Very good centering
- Requires less effort / feed pressure



TURBOMAX® JET POINT

- Specially designed for portable drills
- Excellent centering, will not walk on any surface
- Precision-ground to stay sharp longer and drill faster

HSS DRILL BITS



HSS TURBOMAX



HSS TITANIUM



HSS COBALT



HSS PRO

SPECIALITY DRILL BITS



STEP DRILLS



TCT

TURBOMAX™ HSS



140° CUTTING SHOULDER FOR SMOOTH FINISH

100° TIP FOR FASTEST START

ROBUST REINFORCED WEB DESIGN

W9 HIGH SPEED STEEL (HSS)

HARDENING

GROUND FLUTE

3-FLATTED SHANK

DESIGNED FOR HIGH PERFORMANCE DRILLING

Turbomax™ is designed primarily for high performance drilling in sheet metal, however, also performs well in all types of wood and plastic. Suitable for drilling stainless steel however, HSS Cobalt products (p.114) are designed specifically for this purpose. Remember to always use a coolant when drilling stainless steel.

- 1. 100° TIP FOR FASTEST START**
Most precise centering and guidance
No walking, including curved surfaces
No centre punch necessary
- 2. 140° CUTTING SHOULDER FOR SMOOTH FINISH**
Drills perfectly round holes with clean exit holes - minimised burrs
Will not bind in multiple layers of thin material
- 3. GROUND FLUTE**
Ground from solid for high accuracy drilling and fast removal of chips
- 4. ROBUST REINFORCED WEB DESIGN**
For added strength and durability - no breakage
- 5. W9 HIGH SPEED STEEL (HSS)**
For sharper cutting lips and superb heat resistance
- 6. HARDENING**
Superb wear resistance. Hardness of 63-66 HRC
- 7. 3-FLATTED SHANK**
Prevents slipping in chuck
No damaging of the drill due to slipping
Safe and strong clamping, especially when using keyless chucks

JET POINT – REVOLUTIONARY TIP DESIGN
Self centering, will not walk on any surfaces



JET POINT – REVOLUTIONARY TIP DESIGN
Self centering, will not walk on any surfaces

TURBOMAX™ HSS DRILL BITS

| ITEM NO. | DIAMETER mm | WORKING LENGTH mm | TOTAL LENGTH mm | PCS PER PACK | EAN | MASTER PACK | SHELF PACK |
|----------|----------------|----------------------|--------------------|-----------------|---------------|-------------|------------|
| 10502202 | 1.0 | 12 | 34 | 2 | 5709131232889 | 50 | 10 |
| 10502203 | 1.5 | 18 | 40 | 2 | 5709131232902 | 50 | 10 |
| 10502204 | 2.0 | 24 | 49 | 2 | 5709131232926 | 50 | 10 |
| 10502205 | 2.5 | 30 | 57 | 2 | 5709131232940 | 50 | 10 |
| 10502206 | 3.0 | 33 | 61 | 1 | 5709131232964 | 50 | 10 |
| 10502207 | 3.1 | 36 | 65 | 1 | 5709131232988 | 50 | 10 |
| 10502208 | 3.2 | 36 | 65 | 1 | 5709131233008 | 50 | 10 |
| 10502209 | 3.3 | 36 | 65 | 1 | 5709131233046 | 50 | 10 |
| 10502210 | 3.5 | 39 | 70 | 1 | 5709131233060 | 50 | 10 |
| 10502211 | 4.0 | 43 | 75 | 1 | 5709131233084 | 50 | 10 |
| 10502212 | 4.1 | 43 | 75 | 1 | 5709131233107 | 50 | 10 |
| 10502213 | 4.2 | 43 | 75 | 1 | 5709131233121 | 50 | 10 |
| 10502214 | 4.3 | 47 | 75 | 1 | 5709131233541 | 50 | 10 |
| 10502215 | 4.5 | 47 | 80 | 1 | 5709131233145 | 50 | 10 |
| 10502216 | 4.8 | 52 | 86 | 1 | 5709131233169 | 50 | 10 |
| 10502217 | 4.9 | 52 | 86 | 1 | 5709131233183 | 50 | 10 |
| 10502218 | 5.0 | 52 | 86 | 1 | 5709131233206 | 50 | 10 |
| 10502219 | 5.1 | 52 | 86 | 1 | 5709131233220 | 50 | 10 |
| 10502220 | 5.5 | 57 | 93 | 1 | 5709131233244 | 50 | 10 |
| 10502221 | 6.0 | 57 | 93 | 1 | 5709131233268 | 50 | 10 |
| 10502222 | 6.5 | 63 | 101 | 1 | 5709131233282 | 50 | 10 |
| 10502223 | 7.0 | 69 | 109 | 1 | 5709131233305 | 50 | 10 |
| 10502224 | 7.5 | 69 | 109 | 1 | 5709131233329 | 50 | 10 |
| 10502225 | 8.0 | 75 | 117 | 1 | 5709131233367 | 50 | 10 |
| 10502226 | 8.5 | 75 | 117 | 1 | 5709131233381 | 50 | 10 |
| 10502227 | 9.0 | 81 | 125 | 1 | 5709131233404 | 50 | 10 |
| 10502228 | 9.5 | 81 | 125 | 1 | 5709131233428 | 50 | 10 |
| 10502229 | 10.0 | 87 | 133 | 1 | 5709131233442 | 50 | 10 |
| 10502230 | 11.0 | 94 | 142 | 1 | 5709131233466 | 30 | 10 |
| 10502231 | 12.0 | 101 | 151 | 1 | 5709131233480 | 30 | 10 |
| 10502232 | 13.0 | 101 | 151 | 1 | 5709131233503 | 30 | 10 |



10502225



HSS COBALT

135° SPLIT POINT GRINDING

INDUSTRIAL QUALITY GROUND FLUTE

COBALT ALLOYED DRILL BIT BODY

DESIGNED FOR DRILLING STAINLESS STEEL



GOLDEN TEMPERED SURFACE FINISH

- 1. 135° SPLIT POINT GRINDING**
Ensures perfect centering and reduced drilling pressure
- 2. INDUSTRIAL QUALITY GROUND FLUTE**
For high accuracy drilling and fast removal of chips
- 3. COBALT ALLOYED DRILL BIT BODY**
Manufactured from high quality HSS steel containing 5% Cobalt (Co) – added 5% Cobalt improves the red hardness (heat resistance) and abrasion resistance of the drill bit and results in significantly extended life
- 4. GOLDEN TEMPERED SURFACE FINISH**
For increased durability

HSS COBALT DRILL BITS - DIN 338



| ITEM NO. | DIAMETER mm | WORKING LENGTH mm | TOTAL LENGTH mm | PCS PER PACK | EAN | MASTER PACK | SHELF PACK |
|----------|-------------|-------------------|-----------------|--------------|---------------|-------------|------------|
| 10502507 | 1.0 | 12 | 34 | 2 | 5709131282532 | 200 | 10 |
| 10502508 | 1.5 | 18 | 40 | 2 | 5709131282570 | 200 | 10 |
| 10502509 | 2.0 | 24 | 49 | 2 | 5709131282617 | 200 | 10 |
| 10502510 | 2.5 | 30 | 57 | 2 | 5709131282655 | 200 | 10 |
| 10502542 | 3.0 | 33 | 61 | 1 | 5709131282693 | 200 | 10 |
| 10502543 | 3.1 | 36 | 65 | 1 | 5709131282730 | 200 | 10 |
| 10502544 | 3.2 | 36 | 65 | 1 | 5709131282778 | 200 | 10 |
| 10502545 | 3.3 | 36 | 65 | 1 | 5709131282815 | 200 | 10 |
| 10502546 | 3.5 | 39 | 70 | 1 | 5709131282853 | 200 | 10 |
| 10502547 | 4.0 | 43 | 75 | 1 | 5709131282891 | 200 | 10 |
| 10502548 | 4.1 | 43 | 75 | 1 | 5709131282938 | 200 | 10 |
| 10502549 | 4.2 | 43 | 75 | 1 | 5709131282976 | 200 | 10 |
| 10502550 | 4.3 | 47 | 80 | 1 | 5709131283010 | 200 | 10 |
| 10502551 | 4.5 | 47 | 80 | 1 | 5709131283058 | 200 | 10 |
| 10502552 | 4.8 | 52 | 86 | 1 | 5709131283096 | 200 | 10 |
| 10502553 | 4.9 | 52 | 86 | 1 | 5709131283133 | 200 | 10 |
| 10502554 | 5.0 | 52 | 86 | 1 | 5709131283171 | 200 | 10 |
| 10502555 | 5.1 | 52 | 86 | 1 | 5709131283218 | 200 | 10 |
| 10502556 | 5.5 | 57 | 93 | 1 | 5709131283256 | 200 | 10 |
| 10502557 | 6.0 | 57 | 93 | 1 | 5709131283294 | 200 | 10 |
| 10502558 | 6.5 | 63 | 101 | 1 | 5709131283331 | 100 | 10 |
| 10502559 | 7.0 | 69 | 109 | 1 | 5709131283379 | 100 | 10 |
| 10502560 | 7.5 | 69 | 109 | 1 | 5709131283416 | 100 | 10 |
| 10502561 | 8.0 | 75 | 117 | 1 | 5709131283454 | 100 | 10 |
| 10502562 | 8.5 | 75 | 117 | 1 | 5709131283492 | 100 | 10 |
| 10502563 | 9.0 | 81 | 125 | 1 | 5709131283539 | 100 | 10 |
| 10502564 | 9.5 | 81 | 125 | 1 | 5709131283577 | 100 | 10 |
| 10502565 | 10.0 | 87 | 133 | 1 | 5709131283614 | 100 | 10 |
| 10502566 | 11.0 | 94 | 142 | 1 | 5709131283652 | 50 | 10 |
| 10502567 | 12.0 | 101 | 151 | 1 | 5709131283690 | 50 | 10 |
| 10502568 | 13.0 | 101 | 151 | 1 | 5709131283737 | 50 | 10 |

10502561

HSS COBALT DRILL BITS - DIN 338 - BULK PACK

| ITEM NO. | DIAMETER mm | WORKING LENGTH mm | TOTAL LENGTH mm | PCS PER PACK | EAN | MASTER PACK | SHELF PACK |
|----------|----------------|----------------------|--------------------|-----------------|---------------|-------------|------------|
| 10502511 | 1.0 | 12 | 34 | 10 | 5706915000450 | 50 | 1 |
| 10502512 | 1.5 | 18 | 40 | 10 | 5706915000474 | 50 | 1 |
| 10502513 | 2.0 | 24 | 49 | 10 | 5706915000498 | 50 | 1 |
| 10502514 | 2.5 | 30 | 57 | 10 | 5706915000511 | 50 | 1 |
| 10502515 | 3.0 | 33 | 61 | 10 | 5706915000535 | 50 | 1 |
| 10502516 | 3.1 | 36 | 65 | 10 | 5706915000559 | 50 | 1 |
| 10502517 | 3.2 | 36 | 65 | 10 | 5706915000573 | 50 | 1 |
| 10502518 | 3.3 | 36 | 65 | 10 | 5706915000597 | 50 | 1 |
| 10502519 | 3.5 | 39 | 70 | 10 | 5706915000610 | 50 | 1 |
| 10502520 | 4.0 | 43 | 75 | 10 | 5706915000634 | 50 | 1 |
| 10502521 | 4.1 | 43 | 75 | 10 | 5706915000658 | 50 | 1 |
| 10502522 | 4.2 | 43 | 75 | 10 | 5706915000672 | 50 | 1 |
| 10502523 | 4.3 | 47 | 80 | 10 | 5706915000696 | 50 | 1 |
| 10502524 | 4.5 | 47 | 80 | 10 | 5706915000719 | 50 | 1 |
| 10502525 | 4.8 | 52 | 86 | 10 | 5706915000733 | 50 | 1 |
| 10502526 | 4.9 | 52 | 86 | 10 | 5706915000757 | 50 | 1 |
| 10502527 | 5.0 | 52 | 86 | 10 | 5706915000771 | 50 | 1 |
| 10502528 | 5.1 | 52 | 86 | 10 | 5706915000795 | 50 | 1 |
| 10502529 | 5.5 | 57 | 93 | 10 | 5706915000818 | 20 | 1 |
| 10502530 | 6.0 | 57 | 93 | 10 | 5706915000832 | 50 | 1 |
| 10502531 | 6.5 | 63 | 101 | 10 | 5706915000856 | 20 | 1 |
| 10502532 | 7.0 | 69 | 109 | 10 | 5706915000894 | 20 | 1 |
| 10502533 | 7.5 | 69 | 109 | 5 | 5706915000870 | 40 | 1 |
| 10502534 | 8.0 | 75 | 117 | 5 | 5706915000917 | 40 | 1 |
| 10502535 | 8.5 | 75 | 117 | 5 | 5706915000931 | 40 | 1 |
| 10502536 | 9.0 | 81 | 125 | 5 | 5706915000955 | 40 | 1 |
| 10502537 | 9.5 | 81 | 125 | 5 | 5706915000979 | 40 | 1 |
| 10502538 | 10.0 | 87 | 133 | 5 | 5706915000993 | 40 | 1 |
| 10502539 | 11.0 | 94 | 142 | 5 | 5706915001013 | 20 | 1 |
| 10502540 | 12.0 | 101 | 151 | 5 | 5706915001037 | 20 | 1 |
| 10502541 | 13.0 | 101 | 151 | 5 | 5706915001051 | 20 | 1 |

**ALSO
AVAILABLE
IN SETS**
SEE PAGE 136

HSS TITANIUM



135° SPLIT POINT GRINDING

SPEED AND FEED

TITANIUM NITRIDE (TiN) COATED HIGH QUALITY STEEL BODY

INDUSTRIAL GROUND FLUTE

LESS HEAT TiN

FAST AND PRECISE

- 1. 135° SPLIT POINT GRINDING**
Ensures perfect centering and reduced drilling pressure
- 2. INDUSTRIAL GROUND FLUTE**
For high accuracy drilling and fast removal of chips
- 3. TITANIUM NITRIDE (TiN) COATED HIGH QUALITY STEEL BODY**
Resists heat and friction, providing up to six times longer life than standard metal drill bits*
The TiN coating has a hardness of app. 80 HRC and is very resistant to wear
TiN has a low coefficient of friction. This results in less power being consumed and less heat generated during the drilling
- 4. SPEED AND FEED**
Compared to traditional HSS Twist Drill Bits, speed can be increased by 40 -60% and feed by 10 -20% without reducing the life time of the drill bit significantly
- 5. LESS HEAT**
TiN is also a poor conductor of heat, so the heat generated during the drilling process is diverted into the chips and coolant and less into the drill bit

*Up to 6X longer bit life than black oxide coated bits



| ITEM NO. | DIAMETER mm | WORKING LENGTH mm | TOTAL LENGTH mm | PCS PER PACK | EAN | MASTER PACK | SHELF PACK |
|----------|-------------|-------------------|-----------------|--------------|---------------|-------------|------------|
| 10502572 | 1.0 | 12 | 34 | 2 | 5709131282556 | 200 | 10 |
| 10502573 | 1.5 | 18 | 40 | 2 | 5709131282594 | 200 | 10 |
| 10502574 | 2.0 | 24 | 49 | 2 | 5709131282631 | 200 | 10 |
| 10502575 | 2.5 | 30 | 57 | 2 | 5709131282679 | 200 | 10 |
| 10502576 | 3.0 | 33 | 61 | 1 | 5709131282716 | 200 | 10 |
| 10502577 | 3.1 | 36 | 65 | 1 | 5709131282754 | 200 | 10 |
| 10502578 | 3.2 | 36 | 65 | 1 | 5709131282792 | 200 | 10 |
| 10502579 | 3.3 | 36 | 65 | 1 | 5709131282839 | 200 | 10 |
| 10502580 | 3.5 | 39 | 70 | 1 | 5709131282877 | 200 | 10 |
| 10502581 | 4.0 | 43 | 75 | 1 | 5709131282914 | 200 | 10 |
| 10502582 | 4.1 | 43 | 75 | 1 | 5709131282952 | 200 | 10 |
| 10502583 | 4.2 | 43 | 75 | 1 | 5709131282990 | 200 | 10 |
| 10502584 | 4.3 | 47 | 80 | 1 | 5709131283034 | 200 | 10 |
| 10502585 | 4.5 | 47 | 80 | 1 | 5709131283072 | 200 | 10 |
| 10502586 | 4.8 | 52 | 86 | 1 | 5709131283119 | 200 | 10 |
| 10502587 | 4.9 | 52 | 86 | 1 | 5709131283157 | 200 | 10 |
| 10502588 | 5.0 | 52 | 86 | 1 | 5709131283195 | 200 | 10 |
| 10502589 | 5.1 | 52 | 86 | 1 | 5709131283232 | 200 | 10 |
| 10502590 | 5.5 | 57 | 93 | 1 | 5709131283270 | 200 | 10 |
| 10502591 | 6.0 | 57 | 93 | 1 | 5709131283317 | 200 | 10 |
| 10502592 | 6.5 | 63 | 101 | 1 | 5709131283355 | 100 | 10 |
| 10502593 | 7.0 | 69 | 109 | 1 | 5709131283393 | 100 | 10 |
| 10502594 | 7.5 | 69 | 109 | 1 | 5709131283430 | 100 | 10 |
| 10502595 | 8.0 | 75 | 117 | 1 | 5709131283478 | 100 | 10 |
| 10502596 | 8.5 | 75 | 117 | 1 | 5709131283515 | 100 | 10 |
| 10502597 | 9.0 | 81 | 125 | 1 | 5709131283553 | 100 | 10 |
| 10502598 | 9.5 | 81 | 125 | 1 | 5709131283591 | 100 | 10 |
| 10502599 | 10.0 | 87 | 133 | 1 | 5709131283638 | 100 | 10 |
| 10502600 | 11.0 | 94 | 142 | 1 | 5709131283676 | 50 | 10 |
| 10502601 | 12.0 | 101 | 151 | 1 | 5709131283713 | 50 | 10 |
| 10502602 | 13.0 | 101 | 151 | 1 | 5709131283751 | 50 | 10 |

ALSO AVAILABLE IN SETS
SEE PAGE 136

10502595

HSS PRO



HSS PRO is an industrial quality twist drill with outstanding performance and long service life. It is designed for drilling steel and steel castings, alloyed and non-alloyed steel, cast iron, non-ferrous metals, plastics and other materials. The 118° split point shape provides an optimum centering when starting and a faster drilling rate. It requires lower feed pressure than standard HSS drill bits with a chisel edge.

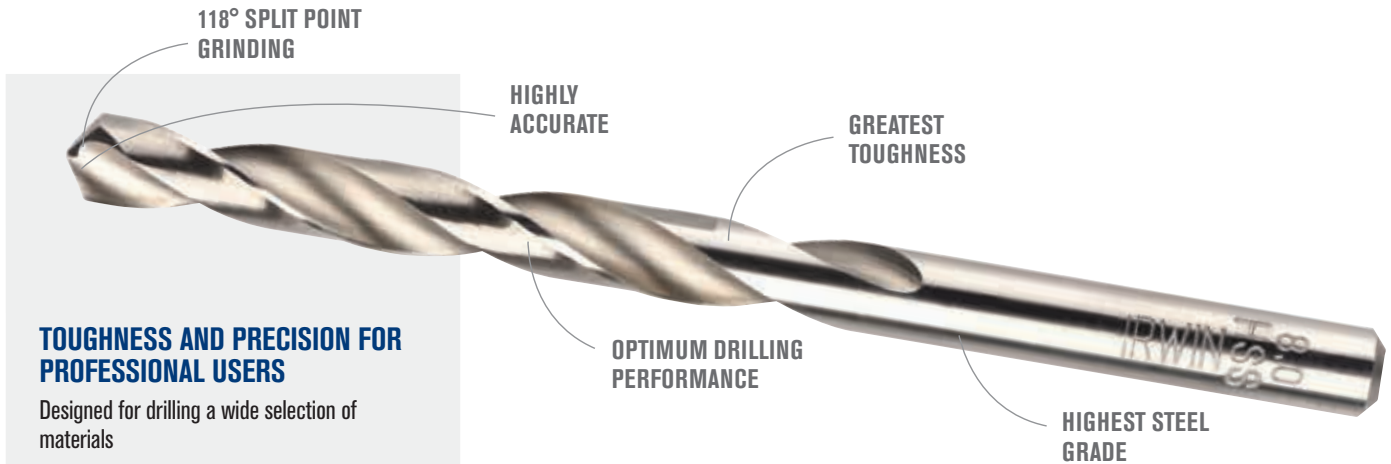

TOUGHNESS AND PRECISION FOR PROFESSIONAL USERS

Designed for drilling a wide selection of materials



- 1. 118° SPLIT POINT SHAPE**
With increased performance and very good centering
Precision starting, no need to pre-punch or pilot drill
Penetrates quickly
Requires less effort / feed pressure
- 2. GREATEST TOUGHNESS**
For low risk of breakage even when drilling with smaller diameters due to high elasticity
- 3. OPTIMUM DRILLING PERFORMANCE**
Even in unfavourable working conditions
- 4. HIGHLY ACCURATE**
Close tolerances and high concentricity for maximum precision
- 5. HIGHEST STEEL GRADE**
High-performance, High-Speed Steel

40% MORE HOLES*

*vs previous version

HSS PRO DRILL RANGE

The HSS PRO drill bits are available for a wide array of applications: DIN 338 jobber series, DIN 340 long series, double-ended stub series, DIN 345 Morse taper shank series.

| | | |
|--------------|--|--------------------------------------------------------------------------------------------------------------------------------------------------------|
| DIN 338 | | DIN 338 series is suitable for many trade and industrial applications in alloyed and un-alloyed steel, non-ferrous metals, cast iron and plastics. |
| DIN 340 | | DIN 340 long series is most suitable for drilling deep holes or through hollow profiles. |
| Double-Ended | | Double-ended series is especially designed for drilling thin materials like sheet metal, flat steel and profiles. Ideal for use with hand-held drills. |
| DIN 345 | | DIN 345 Morse taper shank series offers strong standard drill bits for use with stationary drilling machines. Designed for high breakage resistance. |

HSS PRO DRILL BITS - DIN 338



MANUFACTURED TO DIN 338 STANDARDS ideal for many trade and industrial applications
118° SPLIT POINT SHAPE for increased performance and very good centering
SURFACE FINISH Polished silver
PACKAGED in skin card up to Ø 13 mm, in Quadro Pack from Ø 13.5 mm and above



ALSO AVAILABLE IN SETS
SEE PAGE 137

10502393

| ITEM NO. | DIAMETER mm | WORKING LENGTH mm | TOTAL LENGTH mm | PCS PER PACK | EAN | MASTER PACK | SHELF PACK |
|----------|-------------|-------------------|-----------------|--------------|---------------|-------------|------------|
| 10502376 | 1.0 | 12 | 34 | 3 | 5709131104674 | 200 | 10 |
| 10502377 | 1.5 | 18 | 40 | 3 | 5709131104865 | 200 | 10 |
| 10502378 | 2.0 | 24 | 49 | 3 | 5709131105084 | 200 | 10 |
| 10502379 | 2.5 | 30 | 57 | 3 | 5709131105251 | 200 | 10 |
| 10502380 | 3.0 | 33 | 61 | 3 | 5709131105466 | 200 | 10 |
| 10502381 | 3.2 | 36 | 65 | 2 | 5709131105589 | 200 | 10 |
| 10502382 | 3.3 | 36 | 65 | 2 | 5709131105657 | 200 | 10 |
| 10502383 | 3.5 | 39 | 70 | 2 | 5709131105732 | 200 | 10 |
| 10502384 | 4.0 | 43 | 75 | 2 | 5709131105930 | 200 | 10 |
| 1863343 | 4.1 | 43 | 75 | 2 | 5706918633433 | 200 | 10 |
| 10502385 | 4.2 | 43 | 75 | 2 | 5709131106050 | 200 | 10 |
| 10502386 | 4.5 | 47 | 80 | 2 | 5709131106166 | 200 | 10 |
| 1863344 | 4.8 | 52 | 86 | 2 | 5706918633440 | 200 | 10 |
| 10502387 | 5.0 | 52 | 86 | 2 | 5709131106371 | 200 | 10 |
| 1863345 | 5.1 | 52 | 86 | 1 | 5706918633457 | 200 | 10 |
| 1863346 | 5.2 | 52 | 86 | 1 | 5706918633464 | 200 | 10 |
| 10502388 | 5.5 | 57 | 93 | 1 | 5709131106555 | 200 | 10 |
| 10502389 | 6.0 | 57 | 93 | 1 | 5709131106753 | 200 | 10 |
| 10502390 | 6.5 | 63 | 101 | 1 | 5709131106944 | 200 | 10 |
| 10502391 | 7.0 | 69 | 109 | 1 | 5709131107101 | 100 | 10 |
| 10502392 | 7.5 | 69 | 109 | 1 | 5709131107279 | 100 | 10 |
| 10502393 | 8.0 | 75 | 117 | 1 | 5709131107477 | 100 | 10 |
| 10502394 | 8.5 | 75 | 117 | 1 | 5709131107668 | 100 | 10 |
| 10502395 | 9.0 | 81 | 125 | 1 | 5709131107842 | 100 | 10 |
| 10502396 | 9.5 | 81 | 125 | 1 | 5709131108016 | 100 | 10 |
| 10502397 | 10.0 | 87 | 133 | 1 | 5709131108207 | 100 | 10 |

HSS PRO DRILL BITS - REDUCED SHANK - DIN 338



| ITEM NO. | DIAMETER mm | WORKING LENGTH mm | TOTAL LENGTH mm | PCS PER PACK | EAN | MASTER PACK | SHELF PACK |
|----------|-------------|-------------------|-----------------|--------------|---------------|-------------|------------|
| 10502398 | 10.5 | 87 | 133 | 10mm | 5709131108429 | 50 | 10 |
| 10502399 | 11.0 | 94 | 142 | 10mm | 5709131108597 | 50 | 10 |
| 10502400 | 11.5 | 94 | 142 | 10mm | 5709131108764 | 50 | 10 |
| 10502401 | 12.0 | 101 | 151 | 10mm | 5709131108948 | 50 | 10 |
| 10502402 | 12.5 | 101 | 151 | 10mm | 5709131109099 | 50 | 10 |
| 10502403 | 13.0 | 101 | 151 | 10mm | 5709131109266 | 50 | 10 |
| 10502404 | 13.5 | 108 | 160 | 10mm | 5709131109402 | 50 | 10 |
| 10502405 | 14.0 | 108 | 160 | 10mm | 5709131109471 | 50 | 10 |
| 10502406 | 14.5 | 114 | 169 | 10mm | 5709131109570 | 25 | 5 |
| 10502407 | 15.0 | 114 | 169 | 10mm | 5709131109662 | 25 | 5 |
| 10502408 | 15.5 | 120 | 178 | 10mm | 5709131109730 | 25 | 5 |
| 10502409 | 16.0 | 120 | 178 | 10mm | 5709131109822 | 25 | 5 |
| 10502410 | 16.5 | 125 | 184 | 13mm | 5709131109921 | 25 | 5 |
| 10502411 | 17.0 | 125 | 184 | 13mm | 5709131109990 | 25 | 5 |
| 10502412 | 17.5 | 130 | 191 | 13mm | 5709131110064 | 25 | 5 |
| 10502413 | 18.0 | 130 | 191 | 13mm | 5709131110132 | 25 | 5 |
| 10502414 | 18.5 | 135 | 198 | 13mm | 5709131110200 | 25 | 5 |
| 10502415 | 19.0 | 135 | 198 | 13mm | 5709131110286 | 25 | 5 |
| 10502416 | 19.5 | 140 | 205 | 13mm | 5709131110354 | 25 | 5 |
| 10502417 | 20.0 | 140 | 205 | 13mm | 5709131110439 | 25 | 5 |

METAL DRILLING

HSS PRO DRILL BITS - DIN 338 - BULK PACK



| ITEM NO. | DIAMETER mm | WORKING LENGTH mm | TOTAL LENGTH mm | PCS PER PACK | EAN | MASTER PACK | SHELF PACK |
|----------|----------------|----------------------|--------------------|-----------------|---------------|-------------|------------|
| 10502236 | 0.5 | 6 | 22 | 10 | 5709131035923 | 50 | 1 |
| 10502237 | 0.6 | 7 | 24 | 10 | 5709131035954 | 50 | 1 |
| 10502238 | 0.7 | 9 | 28 | 10 | 5709131035978 | 50 | 1 |
| 10502239 | 0.8 | 10 | 30 | 10 | 5709131035992 | 50 | 1 |
| 10502240 | 0.9 | 11 | 32 | 10 | 5709131036012 | 50 | 1 |
| 10502241 | 1.0 | 12 | 34 | 10 | 5709131036043 | 50 | 1 |
| 10502242 | 1.1 | 14 | 36 | 10 | 5709131036098 | 50 | 1 |
| 10502243 | 1.2 | 16 | 38 | 10 | 5709131036128 | 50 | 1 |
| 10502244 | 1.3 | 16 | 38 | 10 | 5709131036159 | 50 | 1 |
| 10502245 | 1.4 | 18 | 40 | 10 | 5709131036180 | 50 | 1 |
| 10502246 | 1.5 | 18 | 40 | 10 | 5709131036210 | 50 | 1 |
| 10502247 | 1.6 | 20 | 43 | 10 | 5709131036272 | 50 | 1 |
| 10502248 | 1.7 | 20 | 43 | 10 | 5709131036302 | 50 | 1 |
| 10502249 | 1.8 | 22 | 46 | 10 | 5709131036326 | 50 | 1 |
| 10502250 | 1.9 | 22 | 46 | 10 | 5709131036357 | 50 | 1 |
| 10502251 | 2.0 | 24 | 49 | 10 | 5709131036401 | 50 | 1 |
| 10502252 | 2.1 | 24 | 49 | 10 | 5709131036463 | 50 | 1 |
| 10502253 | 2.2 | 27 | 53 | 10 | 5709131036487 | 50 | 1 |
| 10502254 | 2.3 | 27 | 53 | 10 | 5709131036517 | 50 | 1 |
| 10502255 | 2.4 | 30 | 57 | 10 | 5709131036548 | 50 | 1 |
| 10502256 | 2.5 | 30 | 57 | 10 | 5709131036562 | 50 | 1 |
| 10502257 | 2.6 | 30 | 57 | 10 | 5709131036623 | 50 | 1 |
| 10502258 | 2.7 | 33 | 61 | 10 | 5709131036654 | 50 | 1 |
| 10502259 | 2.8 | 33 | 61 | 10 | 5709131036685 | 50 | 1 |
| 10502260 | 2.9 | 33 | 61 | 10 | 5709131036708 | 50 | 1 |
| 10502261 | 3.0 | 33 | 61 | 10 | 5709131036746 | 50 | 1 |
| 10502262 | 3.1 | 36 | 65 | 10 | 5709131036814 | 50 | 1 |
| 10502263 | 3.2 | 36 | 65 | 10 | 5709131036852 | 50 | 1 |
| 10502264 | 3.3 | 36 | 65 | 10 | 5709131036906 | 50 | 1 |
| 10502265 | 3.4 | 39 | 70 | 10 | 5709131036944 | 50 | 1 |
| 10502266 | 3.5 | 39 | 70 | 10 | 5709131036968 | 50 | 1 |
| 10502267 | 3.6 | 39 | 70 | 10 | 5709131037033 | 50 | 1 |
| 10502268 | 3.7 | 39 | 70 | 10 | 5709131037057 | 50 | 1 |
| 10502269 | 3.8 | 43 | 75 | 10 | 5709131037071 | 50 | 1 |
| 10502270 | 3.9 | 43 | 75 | 10 | 5709131037095 | 50 | 1 |
| 10502271 | 4.0 | 43 | 75 | 10 | 5709131231202 | 50 | 1 |
| 10502272 | 4.1 | 43 | 75 | 10 | 5709131037200 | 50 | 1 |
| 10502273 | 4.2 | 43 | 75 | 10 | 5709131037231 | 50 | 1 |
| 10502274 | 4.3 | 47 | 80 | 10 | 5709131037262 | 50 | 1 |
| 10502275 | 4.4 | 47 | 80 | 10 | 5709131037293 | 50 | 1 |
| 10502276 | 4.5 | 47 | 80 | 10 | 5709131037316 | 50 | 1 |
| 10502277 | 4.6 | 47 | 80 | 10 | 5709131037378 | 50 | 1 |
| 10502278 | 4.7 | 47 | 80 | 10 | 5709131037392 | 50 | 1 |
| 10502279 | 4.8 | 52 | 86 | 10 | 5709131037439 | 50 | 1 |
| 10502280 | 4.9 | 52 | 86 | 10 | 5709131037460 | 50 | 1 |
| 10502281 | 5.0 | 52 | 86 | 10 | 5709131037491 | 50 | 1 |
| 10502282 | 5.1 | 52 | 86 | 10 | 5709131037569 | 50 | 1 |
| 10502283 | 5.2 | 52 | 86 | 10 | 5709131037606 | 50 | 1 |
| 10502284 | 5.3 | 52 | 86 | 10 | 5709131037620 | 50 | 1 |
| 10502285 | 5.4 | 57 | 93 | 10 | 5709131037644 | 50 | 1 |
| 10502286 | 5.5 | 57 | 93 | 10 | 5709131037668 | 50 | 1 |
| 10502287 | 5.6 | 57 | 93 | 10 | 5709131037729 | 50 | 1 |
| 10502288 | 5.7 | 57 | 93 | 10 | 5709131037743 | 50 | 1 |
| 10502289 | 5.8 | 57 | 93 | 10 | 5709131037774 | 50 | 1 |
| 10502290 | 5.9 | 57 | 93 | 10 | 5709131037798 | 50 | 1 |
| 10502291 | 6.0 | 57 | 93 | 10 | 5709131037835 | 50 | 1 |
| 10502292 | 6.1 | 63 | 101 | 10 | 5709131037903 | 50 | 1 |
| 10502293 | 6.2 | 63 | 101 | 10 | 5709131037934 | 20 | 1 |
| 10502294 | 6.3 | 63 | 101 | 10 | 5709131037958 | 20 | 1 |
| 10502295 | 6.4 | 63 | 101 | 10 | 5709131037989 | 20 | 1 |
| 10502296 | 6.5 | 63 | 101 | 10 | 5709131038016 | 20 | 1 |
| 10502297 | 6.6 | 63 | 101 | 10 | 5709131038061 | 20 | 1 |

HSS PRO DRILL BITS - DIN 338 - BULK PACK

10502311



| ITEM NO. | DIAMETER mm | WORKING LENGTH mm | TOTAL LENGTH mm | PCS PER PACK | EAN | MASTER PACK | SHELF PACK |
|----------|----------------|----------------------|--------------------|-----------------|---------------|-------------|------------|
| 10502299 | 6.8 | 69 | 109 | 10 | 5709131038115 | 20 | 1 |
| 10502300 | 6.9 | 69 | 109 | 10 | 5709131038139 | 20 | 1 |
| 10502301 | 7.0 | 69 | 109 | 10 | 5709131038153 | 20 | 1 |
| 10502302 | 7.1 | 69 | 109 | 5 | 5709131038207 | 40 | 1 |
| 10502303 | 7.2 | 69 | 109 | 5 | 5709131038238 | 40 | 1 |
| 10502304 | 7.3 | 69 | 109 | 5 | 5709131038269 | 40 | 1 |
| 10502305 | 7.4 | 69 | 109 | 5 | 5709131038283 | 40 | 1 |
| 10502306 | 7.5 | 69 | 109 | 5 | 5709131038306 | 40 | 1 |
| 10502307 | 7.6 | 75 | 117 | 5 | 5709131038368 | 40 | 1 |
| 10502308 | 7.7 | 75 | 117 | 5 | 5709131038382 | 40 | 1 |
| 10502309 | 7.8 | 75 | 117 | 5 | 5709131038405 | 40 | 1 |
| 10502310 | 7.9 | 75 | 117 | 5 | 5709131038429 | 40 | 1 |
| 10502311 | 8.0 | 75 | 117 | 5 | 5709131038474 | 40 | 1 |
| 10502312 | 8.1 | 75 | 117 | 5 | 5709131038559 | 40 | 1 |
| 10502313 | 8.2 | 75 | 117 | 5 | 5709131038580 | 40 | 1 |
| 10502314 | 8.3 | 75 | 117 | 5 | 5709131038603 | 40 | 1 |
| 10502315 | 8.4 | 75 | 117 | 5 | 5709131038634 | 40 | 1 |
| 10502316 | 8.5 | 75 | 117 | 5 | 5709131038658 | 40 | 1 |
| 10502317 | 8.6 | 81 | 125 | 5 | 5709131038702 | 40 | 1 |
| 10502318 | 8.7 | 81 | 125 | 5 | 5709131038733 | 40 | 1 |
| 10502319 | 8.8 | 81 | 125 | 5 | 5709131038764 | 40 | 1 |
| 10502320 | 8.9 | 81 | 125 | 5 | 5709131038788 | 40 | 1 |
| 10502321 | 9.0 | 81 | 125 | 5 | 5709131038818 | 40 | 1 |
| 10502322 | 9.1 | 81 | 125 | 5 | 5709131038863 | 40 | 1 |
| 10502323 | 9.2 | 81 | 125 | 5 | 5709131038894 | 40 | 1 |
| 10502324 | 9.3 | 81 | 125 | 5 | 5709131038917 | 40 | 1 |
| 10502325 | 9.4 | 81 | 125 | 5 | 5709131038931 | 40 | 1 |
| 10502326 | 9.5 | 81 | 125 | 5 | 5709131038962 | 40 | 1 |
| 10502327 | 9.6 | 87 | 133 | 5 | 5709131039020 | 40 | 1 |
| 10502328 | 9.7 | 87 | 133 | 5 | 5709131039051 | 40 | 1 |
| 10502329 | 9.8 | 87 | 133 | 5 | 5709131039075 | 40 | 1 |
| 10502330 | 9.9 | 87 | 133 | 5 | 5709131039099 | 40 | 1 |
| 10502331 | 10.0 | 87 | 133 | 5 | 5709131039129 | 40 | 1 |
| 10502332 | 10.1 | 87 | 133 | 5 | 5709131184638 | 20 | 1 |
| 10502333 | 10.2 | 87 | 133 | 5 | 5709131039211 | 20 | 1 |
| 10502334 | 10.3 | 87 | 133 | 5 | 5709131039242 | 20 | 1 |
| 10502335 | 10.4 | 87 | 133 | 5 | 5709131039273 | 20 | 1 |
| 10502336 | 10.5 | 87 | 133 | 5 | 5709131039297 | 20 | 1 |
| 10502337 | 10.6 | 87 | 133 | 5 | 5709131039365 | 20 | 1 |
| 10502338 | 10.7 | 94 | 142 | 5 | 5709131039389 | 20 | 1 |
| 10502339 | 10.8 | 94 | 142 | 5 | 5709131163114 | 20 | 1 |
| 10502340 | 10.9 | 94 | 142 | 5 | 5709131039419 | 20 | 1 |
| 10502341 | 11.0 | 94 | 142 | 5 | 5709131039433 | 20 | 1 |
| 10502342 | 11.1 | 94 | 142 | 5 | 5709131039501 | 20 | 1 |
| 10502343 | 11.2 | 94 | 142 | 5 | 5709131039525 | 20 | 1 |
| 10502344 | 11.3 | 94 | 142 | 5 | 5709131039549 | 20 | 1 |
| 10502345 | 11.4 | 94 | 142 | 5 | 5709131039563 | 20 | 1 |
| 10502346 | 11.5 | 94 | 142 | 5 | 5709131039587 | 20 | 1 |
| 10502348 | 11.7 | 94 | 142 | 5 | 5709131039679 | 20 | 1 |
| 10502349 | 11.8 | 94 | 142 | 5 | 5709131039686 | 20 | 1 |
| 10502350 | 11.9 | 101 | 151 | 5 | 5709131039709 | 20 | 1 |
| 10502351 | 12.0 | 101 | 151 | 5 | 5709131039723 | 20 | 1 |
| 10502352 | 12.1 | 101 | 151 | 5 | 5709131039792 | 20 | 1 |
| 10502353 | 12.2 | 101 | 151 | 5 | 5709131039822 | 20 | 1 |
| 10502355 | 12.4 | 101 | 151 | 5 | 5709131039853 | 20 | 1 |
| 10502356 | 12.5 | 101 | 151 | 5 | 5709131039877 | 20 | 1 |
| 10502357 | 12.6 | 101 | 151 | 5 | 5709131039921 | 20 | 1 |
| 10502358 | 12.7 | 101 | 151 | 5 | 5709131039945 | 20 | 1 |
| 10502360 | 12.9 | 101 | 151 | 5 | 5709131039990 | 20 | 1 |
| 10502361 | 13.0 | 101 | 151 | 5 | 5709131040002 | 20 | 1 |
| 10502362 | 13.5 | 108 | 160 | 5 | 5709131281085 | 20 | 1 |
| 10502363 | 14.0 | 108 | 160 | 1 | 5709131040163 | 25 | 1 |
| 10502364 | 14.5 | 114 | 169 | 1 | 5709131040200 | 25 | 1 |
| 10502365 | 15.0 | 114 | 169 | 1 | 5709131040262 | 25 | 1 |
| 10502366 | 15.5 | 120 | 178 | 1 | 5709131040316 | 25 | 1 |

HSS PRO DRILL BITS - DIN 338 - BULK PACK



| ITEM NO. | DIAMETER mm | WORKING LENGTH mm | TOTAL LENGTH mm | PCS PER PACK | EAN | MASTER PACK | SHELF PACK |
|----------|-------------|-------------------|-----------------|--------------|---------------|-------------|------------|
| 10502367 | 16.0 | 120 | 178 | 1 | 5709131040354 | 25 | 1 |
| 10502368 | 16.5 | 125 | 184 | 1 | 5709131040408 | 25 | 1 |
| 10502369 | 17.0 | 125 | 184 | 1 | 5709131040460 | 25 | 1 |
| 10502370 | 17.5 | 130 | 191 | 1 | 5709131040507 | 25 | 1 |
| 10502371 | 18.0 | 130 | 191 | 1 | 5709131040545 | 25 | 1 |
| 10502372 | 18.5 | 135 | 198 | 1 | 5709131040583 | 25 | 1 |
| 10502373 | 19.0 | 135 | 198 | 1 | 5709131040620 | 25 | 1 |
| 10502374 | 19.5 | 140 | 205 | 1 | 5709131040675 | 25 | 1 |
| 10502375 | 20.0 | 140 | 205 | 1 | 5709131040712 | 25 | 1 |

HSS PRO LONG DRILL BITS - DIN 340



| ITEM NO. | DIAMETER mm | WORKING LENGTH mm | TOTAL LENGTH mm | PCS PER PACK | EAN | MASTER PACK | SHELF PACK |
|----------|-------------|-------------------|-----------------|--------------|---------------|-------------|------------|
| 1863347 | 3.0 | 70 | 110 | 1 | 5706918633471 | 200 | 10 |
| 1863348 | 4.0 | 80 | 120 | 1 | 5706918633488 | 200 | 10 |
| 1863349 | 5.0 | 90 | 135 | 1 | 5706918633495 | 200 | 10 |
| 1863350 | 6.0 | 95 | 140 | 1 | 5706918633501 | 200 | 10 |
| 1863361 | 8.0 | 105 | 160 | 1 | 5706918633617 | 100 | 10 |
| 1863362 | 10.0 | 115 | 175 | 1 | 5706918633624 | 100 | 10 |

MANUFACTURED TO DIN 340 STANDARDS for drilling deep holes or through hollow profiles
118° SPLIT POINT SHAPE for increased performance and very good centering
SURFACE FINISH is polished silver
PACKAGED in skin card

HSS PRO LONG DRILL BITS - DIN 340 - BULK PACK

| ITEM NO. | DIAMETER mm | WORKING LENGTH mm | TOTAL LENGTH mm | PCS PER PACK | EAN | MASTER PACK | SHELF PACK |
|----------|-------------|-------------------|-----------------|--------------|---------------|-------------|------------|
| 10502482 | 2.0 | 55 | 85 | 10 | 5709131061755 | 20 | 1 |
| 10502483 | 2.5 | 65 | 100 | 10 | 5709131041931 | 20 | 1 |
| 10502484 | 3.0 | 70 | 110 | 10 | 5709131041948 | 20 | 1 |
| 10503855 | 3.2 | 70 | 110 | 10 | 5706915938555 | 20 | 1 |
| 10502485 | 3.5 | 80 | 120 | 10 | 5709131041955 | 20 | 1 |
| 10502486 | 4.0 | 80 | 120 | 10 | 5709131041962 | 20 | 1 |
| 10503856 | 4.2 | 80 | 120 | 10 | 5706915938562 | 20 | 1 |
| 10502487 | 4.5 | 85 | 130 | 10 | 5709131041986 | 20 | 1 |
| 10504418 | 4.8 | 87 | 132 | 10 | 5706915944181 | 20 | 1 |
| 10502488 | 5.0 | 90 | 135 | 10 | 5709131041993 | 20 | 1 |
| 10504420 | 5.2 | 91 | 139 | 10 | 5706915944204 | 20 | 1 |
| 10502489 | 5.5 | 95 | 140 | 10 | 5709131042013 | 20 | 1 |
| 10502490 | 6.0 | 95 | 140 | 10 | 5709131042020 | 20 | 1 |
| 10502491 | 6.5 | 100 | 150 | 10 | 5709131111856 | 20 | 1 |
| 10502492 | 7.0 | 100 | 150 | 10 | 5709131042037 | 20 | 1 |
| 10502493 | 7.5 | 105 | 160 | 5 | 5709131061762 | 20 | 1 |
| 10502494 | 8.0 | 105 | 160 | 5 | 5709131042044 | 20 | 1 |
| 10502495 | 8.5 | 105 | 160 | 5 | 5709131111900 | 20 | 1 |
| 10502496 | 9.0 | 110 | 170 | 5 | 5709131061786 | 20 | 1 |
| 10502497 | 9.5 | 115 | 175 | 5 | 5709131061793 | 20 | 1 |
| 10502498 | 10.0 | 115 | 175 | 5 | 5709131042051 | 20 | 1 |
| 10503858 | 12.0 | 134 | 205 | 5 | 5706915938586 | 20 | 1 |

HSS PRO DOUBLE-ENDED DRILL BITS - BULK PACK



| ITEM NO. | DIAMETER mm | WORKING LENGTH mm | TOTAL LENGTH mm | PCS PER PACK | EAN | MASTER PACK | SHELF PACK |
|----------|-------------|-------------------|-----------------|--------------|---------------|-------------|------------|
| 1868262 | 3.0 | 11 | 46 | 10 | 5706918682622 | 50 | 1 |
| 1868263 | 3.1 | 12 | 49 | 10 | 5706918682639 | 50 | 1 |
| 1868264 | 3.2 | 12 | 49 | 10 | 5706918682646 | 50 | 1 |
| 10502479 | 3.3 | 12 | 49 | 10 | 5709131041559 | 50 | 1 |
| 1868265 | 3.5 | 14 | 52 | 10 | 5706918682653 | 50 | 1 |
| 1868266 | 4.0 | 14 | 56 | 10 | 5706918682660 | 50 | 1 |
| 10502480 | 4.1 | 14 | 56 | 10 | 5709131041634 | 50 | 1 |
| 1868267 | 4.2 | 14 | 56 | 10 | 5706918682677 | 50 | 1 |
| 10502481 | 4.5 | 18 | 62 | 10 | 5709131041702 | 50 | 1 |

118° SPLIT POINT SHAPE for increased performance and very good centering
PARTICULARLY SUITED for drilling thin materials, especially for car body work and tubular rivet holes
DOUBLE LIFETIME versus a single end drill bit
ADAPTED DIAMETERS for most common blind rivets
SURFACE FINISH is polished silver
PACKAGED in Quadro Pack

HSS PRO DRILL BITS - DIN 345 - TAPER SHANK



MANUFACTURED TO DIN 345 STANDARDS for use with stationary drilling machines
118° CHISEL POINT SHAPE for maximum service life
MORSE TAPER SHANK DESIGN for high breakage resistance
SURFACE FINISH is black oxide coating for added corrosion resistance
PACKAGED in Quadro Pack



10502434

| ITEM NO. | DIAMETER mm | WORKING LENGTH mm | TOTAL LENGTH mm | PCS PER PACK | SHANK SIZE | EAN | PACK | SHELF PACK |
|----------|-------------|-------------------|-----------------|--------------|------------|---------------|------|------------|
| 10502418 | 10.0 | 87 | 168 | 5 | MK 1 | 5709131039181 | 10 | 1 |
| 10502419 | 10.5 | 87 | 168 | 5 | MK 1 | 5709131039327 | 10 | 1 |
| 10502420 | 11.0 | 94 | 175 | 5 | MK 1 | 5709131039464 | 10 | 1 |
| 10502422 | 12.0 | 101 | 182 | 5 | MK 1 | 5709131039754 | 10 | 1 |
| 10502424 | 13.0 | 101 | 182 | 5 | MK 1 | 5709131040026 | 10 | 1 |
| 10502425 | 13.5 | 108 | 189 | 5 | MK 1 | 5709131040132 | 10 | 1 |
| 10502426 | 14.0 | 108 | 189 | 1 | MK 1 | 5709131040170 | 25 | 1 |
| 10502427 | 14.5 | 114 | 212 | 1 | MK 2 | 5709131040231 | 25 | 1 |
| 10502428 | 15.0 | 114 | 212 | 1 | MK 2 | 5709131040286 | 25 | 1 |
| 10502429 | 15.5 | 120 | 218 | 1 | MK 2 | 5709131040323 | 25 | 1 |
| 10502430 | 16.0 | 120 | 218 | 1 | MK 2 | 5709131040378 | 25 | 1 |
| 10502431 | 16.5 | 125 | 223 | 1 | MK 2 | 5709131040439 | 25 | 1 |
| 10502432 | 17.0 | 125 | 223 | 1 | MK 2 | 5709131040477 | 25 | 1 |
| 10502433 | 17.5 | 130 | 228 | 1 | MK 2 | 5709131040514 | 25 | 1 |
| 10502434 | 18.0 | 130 | 228 | 1 | MK 2 | 5709131040552 | 25 | 1 |
| 10502435 | 18.5 | 135 | 233 | 1 | MK 2 | 5709131040590 | 25 | 1 |
| 10502436 | 19.0 | 135 | 233 | 1 | MK 2 | 5709131040637 | 25 | 1 |
| 10502437 | 19.5 | 140 | 238 | 1 | MK 2 | 5709131040682 | 25 | 1 |
| 10502438 | 20.0 | 140 | 238 | 1 | MK 2 | 5709131040729 | 25 | 1 |
| 10502439 | 20.5 | 145 | 243 | 1 | MK 2 | 5709131040767 | 25 | 1 |
| 10502440 | 21.0 | 145 | 243 | 1 | MK 2 | 5709131040781 | 25 | 1 |
| 10502441 | 21.5 | 150 | 248 | 1 | MK 2 | 5709131040804 | 25 | 1 |
| 10502442 | 22.0 | 150 | 248 | 1 | MK 2 | 5709131040828 | 25 | 1 |
| 10502443 | 22.5 | 155 | 253 | 1 | MK 2 | 5709131040859 | 25 | 1 |
| 10502444 | 23.0 | 155 | 253 | 1 | MK 2 | 5709131040873 | 25 | 1 |
| 10502445 | 23.5 | 160 | 281 | 1 | MK 3 | 5709131040903 | 25 | 1 |
| 10502446 | 24.0 | 160 | 281 | 1 | MK 3 | 5709131040910 | 25 | 1 |
| 10502447 | 24.5 | 160 | 281 | 1 | MK 3 | 5709131040927 | 25 | 1 |
| 10502448 | 25.0 | 160 | 281 | 1 | MK 3 | 5709131040934 | 25 | 1 |
| 10502450 | 26.0 | 165 | 286 | 1 | MK 3 | 5709131040965 | 25 | 1 |
| 10502451 | 26.5 | 165 | 286 | 1 | MK 3 | 5709131040972 | 10 | 1 |
| 10502452 | 27.0 | 170 | 291 | 1 | MK 3 | 5709131040989 | 10 | 1 |
| 10502453 | 27.5 | 170 | 291 | 1 | MK 3 | 5709131040996 | 10 | 1 |
| 10502454 | 28.0 | 170 | 291 | 1 | MK 3 | 5709131041009 | 10 | 1 |
| 10502456 | 29.0 | 175 | 296 | 1 | MK 3 | 5709131041023 | 10 | 1 |
| 10502458 | 30.0 | 175 | 296 | 1 | MK 3 | 5709131041054 | 10 | 1 |
| 10502460 | 31.0 | 180 | 301 | 1 | MK 3 | 5709131041078 | 10 | 1 |
| 10502461 | 31.5 | 180 | 301 | 1 | MK 3 | 5709131041092 | 10 | 1 |
| 10502462 | 32.0 | 185 | 334 | 1 | MK 4 | 5709131041115 | 10 | 1 |
| 10502464 | 33.0 | 185 | 334 | 1 | MK 4 | 5709131041139 | 5 | 1 |
| 10502466 | 34.0 | 190 | 339 | 1 | MK 4 | 5709131041153 | 5 | 1 |
| 10502468 | 35.0 | 190 | 339 | 1 | MK 4 | 5709131041177 | 5 | 1 |
| 10502470 | 36.0 | 195 | 344 | 1 | MK 4 | 5709131041207 | 5 | 1 |
| 10502474 | 38.0 | 200 | 349 | 1 | MK 4 | 5709131041245 | 5 | 1 |
| 10502478 | 40.0 | 200 | 349 | 1 | MK 4 | 5709131041283 | 5 | 1 |



STEP DRILLS

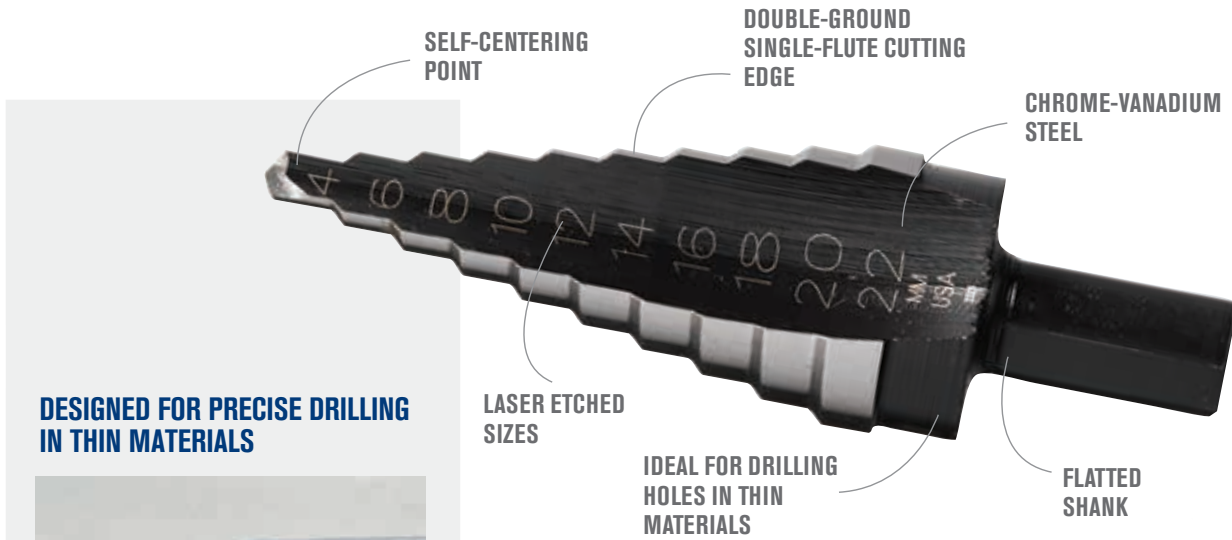

DESIGNED FOR PRECISE DRILLING IN THIN MATERIALS

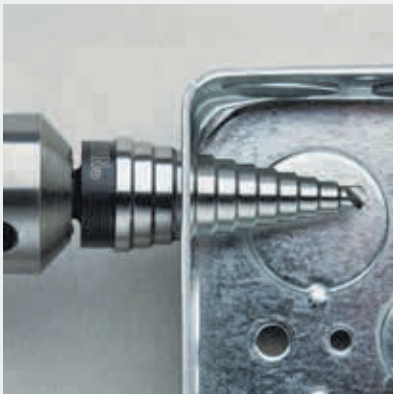

- 1. SELF CENTERING POINT**
Will not walk and eliminates the need for centre punching.
- 2. CHROME-VANADIUM STEEL**
Drill bit body is hardened to 56 HRC for durability.
- 3. DOUBLE-GROUND SINGLE-FLUTE CUTTING EDGE**
For extra chip capacity, drilling of true, round holes and provides maximum step control.
- 4. IDEAL FOR DRILLING HOLES IN THIN MATERIALS**
Including mild steel, copper, brass, aluminium, plexiglass, plastic, wood and laminates.
- 5. FLATTED SHANK**
Prevents the drill bit from slipping in the chuck.
- 6. LASER ETCHED SIZES**
Inside flute for easy and permanent hole size identification.

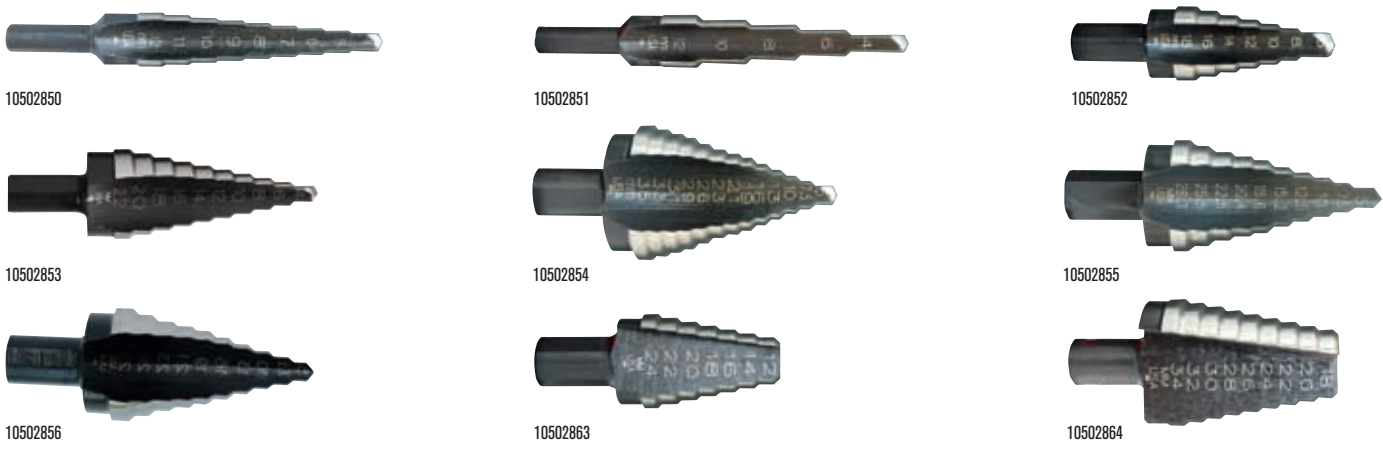

| ITEM NO. | DESCRIPTION | EAN | MASTER PACK | SHELF PACK |
|----------|-----------------------------------------------------------------------------------------------|-------------|-------------|------------|
| 10502850 | 1M 9 Hole sizes (4mm - 12mm), 1mm increments | 38548111018 | 5 | 1 |
| 10502851 | 2M 5 Hole sizes (4mm - 12mm), 2mm increments | 38548111025 | 5 | 1 |
| 10502852 | 3M 7 Hole sizes (6mm - 18mm), 2mm increments | 38548111032 | 5 | 1 |
| 10502853 | 4M 10 Hole sizes (4mm - 22mm), 2mm increments | 38548111049 | 5 | 1 |
| 10502854 | 5M 13 Hole sizes (5mm - 35mm), 2 - 3mm increments | 38548111056 | 5 | 1 |
| 10502855 | PG29M10 Hole sizes 5, 7.5, 10, 12.5, 15.2, 18.6, 20.4, 22.5, 25.5, 28.3mm | 38548111940 | 5 | 1 |
| 10502856 | 29MM 10 Hole sizes 5, 7.5, 10, 13, 16, 19, 21, 23, 26, 29mm | 38548111957 | 5 | 1 |
| 10502857 | ISO/PG13 Hole sizes 5, 7.5, 9.7, 12.7, 15.2, 16.2, 18.6, 20.4, 22.5, 25.4, 28.3, 30.5, 32.5mm | 38548111967 | 5 | 1 |
| 10502863 | 20M 6 Hole sizes (14 - 24mm) | 38548112206 | 5 | 1 |
| 10502864 | 21M 8 Hole sizes (20 - 34mm) | 38548112213 | 5 | 1 |



TCT DRILL BITS

Designed for drilling hard and abrasive materials



HSS PRO DRILL BITS - DIN 338

| | ITEM NO. | DIAMETER mm | WORKING LENGTH mm | TOTAL LENGTH mm | EAN | MASTER PACK | SHELF PACK |
|-----------------------------------------------------------------------------------------------------------------------------------------------------------------------------------------------------------------------------------------------------------------------------------------------------------------------------------------------------------------------------------------------------------------------------------------------------------|----------|----------------|----------------------|--------------------|---------------|-------------|------------|
| FOUR FACETED GROUND CARBIDE TIP for low drilling pressure and perfect centering EXTRA DEEP GROUND DOUBLE FLUTES for extra chip capacity REDUCED FLUTE for body clearance and less friction CHROME-VANADIUM STEEL BODY is hardened to 56 HRC for durability. ALWAYS USE COOLANT when drilling with TCT Twist Drill Bits to extend the life time of the drill bit. It is recommended to use a 3-6% emulsion. | 10502618 | 2.0 | 24 | 51 | 5709131042235 | 50 | 10 |
| | 10502619 | 2.5 | 30 | 57 | 5709131042372 | 50 | 10 |
| | 10502620 | 3.0 | 33 | 61 | 5709131042549 | 50 | 10 |
| | 10502621 | 3.1 | 39 | 70 | 5709131042570 | 50 | 10 |
| | 10502622 | 3.2 | 39 | 70 | 5709131042617 | 50 | 10 |
| | 10502624 | 3.3 | 39 | 70 | 5709131042662 | 50 | 10 |
| | 10502626 | 3.5 | 39 | 70 | 5709131042723 | 50 | 10 |
| | 10502627 | 3.6 | 43 | 75 | 5709131042761 | 50 | 10 |
| | 10502631 | 4.0 | 43 | 75 | 5709131042907 | 50 | 10 |
| | 10502633 | 4.2 | 47 | 80 | 5709131042976 | 50 | 10 |
| | 10502634 | 4.3 | 47 | 80 | 5709131043010 | 50 | 10 |
| | 10502636 | 4.5 | 47 | 80 | 5709131043089 | 50 | 10 |
| | 10502641 | 5.0 | 52 | 86 | 5709131043270 | 50 | 10 |
| | 10502642 | 5.1 | 57 | 93 | 5709131043324 | 50 | 10 |
| | 10502643 | 5.2 | 57 | 93 | 5709131043362 | 50 | 10 |
| | 10502644 | 5.3 | 57 | 93 | 5709131043409 | 50 | 10 |
| 10502646 | 5.5 | 57 | 93 | 5709131043461 | 50 | 10 | |
| 10502649 | 5.8 | 57 | 93 | 5709131043577 | 50 | 10 | |
| 10502651 | 6.0 | 57 | 93 | 5709131043645 | 50 | 10 | |
| 10502656 | 6.5 | 63 | 101 | 5709131043829 | 50 | 10 | |
| 10502658 | 6.7 | 69 | 109 | 5709131043881 | 50 | 10 | |
| 10502659 | 6.8 | 69 | 109 | 5709131043935 | 50 | 10 | |
| 10502661 | 7.0 | 69 | 109 | 5709131043980 | 50 | 10 | |
| 10502662 | 7.1 | 69 | 109 | 5709131044017 | 50 | 10 | |
| 10502666 | 7.5 | 69 | 109 | 5709131044147 | 50 | 10 | |
| 10502671 | 8.0 | 75 | 117 | 5709131044307 | 50 | 10 | |
| 10502676 | 8.5 | 75 | 117 | 5709131044475 | 50 | 10 | |
| 10502680 | 9.0 | 81 | 125 | 5709131044659 | 50 | 10 | |
| 10502685 | 9.5 | 81 | 125 | 5709131044772 | 50 | 10 | |
| 10502689 | 10.0 | 87 | 133 | 5709131044949 | 50 | 10 | |
| 10502690 | 10.5 | 87 | 133 | 5709131045137 | 30 | 10 | |
| 10502691 | 11.0 | 94 | 142 | 5709131045274 | 30 | 10 | |
| 10502692 | 11.5 | 94 | 142 | 5709131045397 | 30 | 10 | |
| 10502693 | 12.0 | 101 | 151 | 5709131045564 | 30 | 10 | |
| 10502694 | 12.5 | 101 | 151 | 5709131045700 | 30 | 10 | |
| 10502695 | 13.0 | 101 | 151 | 5709131045847 | 30 | 10 | |
| 10502696 | 13.5 | 108 | 160 | 5709131045892 | 30 | 10 | |
| 10502697 | 14.0 | 108 | 160 | 5709131045922 | 30 | 10 | |
| 10502699 | 15.0 | 114 | 169 | 5709131045991 | 15 | 10 | |
| 10502701 | 16.0 | 120 | 178 | 5709131046097 | 15 | 5 | |



10502671

WOOD DRILLING



IRWIN®

In 1885, Charles Irwin patented the Auger bit and, along with four business partners, formed the IRWIN® Auger Bit Company in Ohio, USA. Over 125 years later, IRWIN® is still the leading manufacturer of wood drilling bits and accessories. No matter what wood drilling project you face, IRWIN® Tools makes a drill bit that performs the job better. Our mark of quality is stamped right on the shank of our full range of bits. Whether the job requires quick, clean holes, or precise finish work, IRWIN® has a bit for every application and every need.

Professionals can now improve their productivity and accuracy with IRWIN®'s innovative ranges. IRWIN® Blue Groove 4X and Blue Groove 6X wood boring bits raise-the-bar on tool quality and performance. The cutting edge technology incorporates true "cutting edges" that glide through the wood versus scraping its way through. The latest generation Blue Groove Power is adding extreme durability thanks to Bi-Metal Technology.



TRI-FLUTE & FLAT BITS



BLUE GROOVE POWER



BLUE GROOVE 6X



BLUE GROOVE 4X

TRADITIONAL BITS



AUGER



BRAD POINT

EXTENSIONS



QUICK-CHANGE EXTENSIONS



STANDARD EXTENSIONS

BLUE GROOVE POWER WOOD BORING BITS

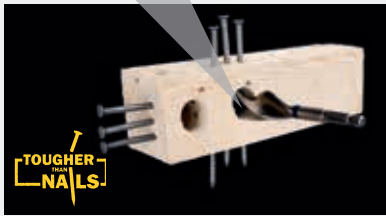
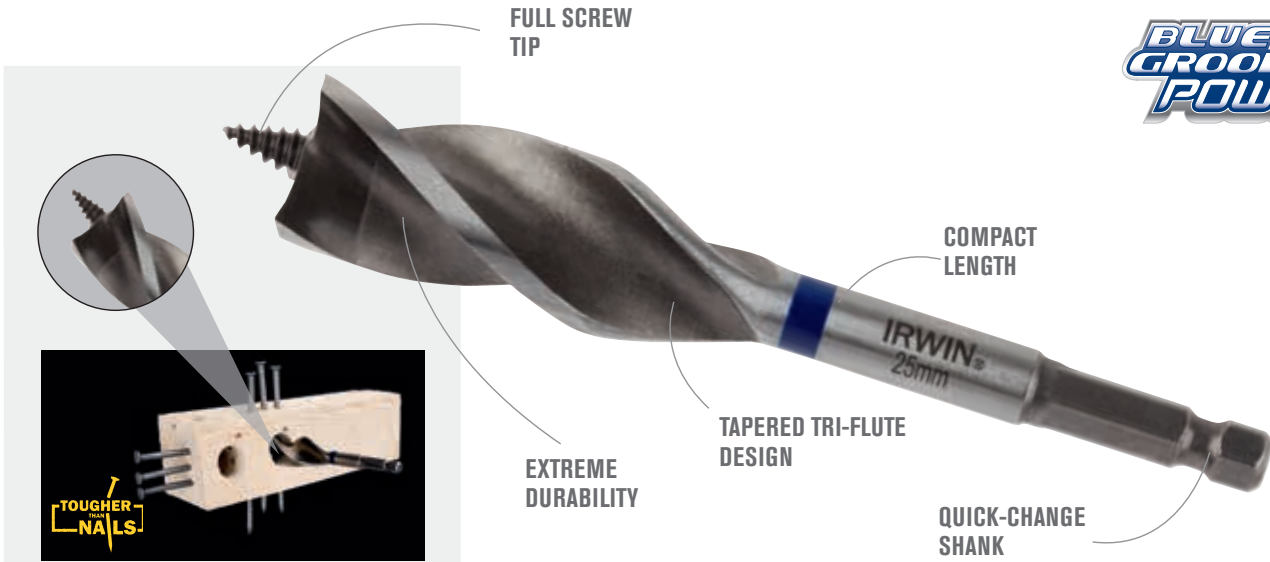

THE LONGEST LASTING WOOD BORING BIT



*Up to 6 times faster than competitor products



*Up to 50 times more durable than competitor products.



Quick Change Shank



Nail-Embedded Wood

1. EXTREME DURABILITY

HSS tip manufactured with Bi-Metal technology cutting edges provide long life in tough applications including nail-embedded wood

2. FULL SCREW TIP

For easy pull through and added accuracy

3. TAPERED TRI-FLUTE DESIGN

For faster chip ejection, less binding and ease of use

4. COMPACT LENGTH

Designed to fit between studs in most common applications

5. QUICK-CHANGE SHANK

1/4" Quick-Change shank on 14-16mm bits and 3/8" Quick-Change shank on 18-32mm bits



| ITEM NO. | DESCRIPTION | EAN | MASTER PACK | SHELF PACK |
|----------|-----------------------|---------------|-------------|------------|
| 10507712 | BlueGroove Power 14mm | 5706915077124 | 36 | 1 |
| 10507713 | BlueGroove Power 16mm | 5706915077131 | 36 | 1 |
| 10507714 | BlueGroove Power 18mm | 5706915077148 | 36 | 1 |
| 10507715 | BlueGroove Power 20mm | 5706915077155 | 36 | 1 |
| 10507716 | BlueGroove Power 22mm | 5706915077162 | 36 | 1 |
| 10507717 | BlueGroove Power 25mm | 5706915077179 | 36 | 1 |
| 10507718 | BlueGroove Power 28mm | 5706915077186 | 36 | 1 |
| 10507719 | BlueGroove Power 32mm | 5706915077193 | 36 | 1 |

ALSO AVAILABLE IN SETS SEE PAGE 137



10507713

BLUE GROOVE 6X WOOD BORING BITS

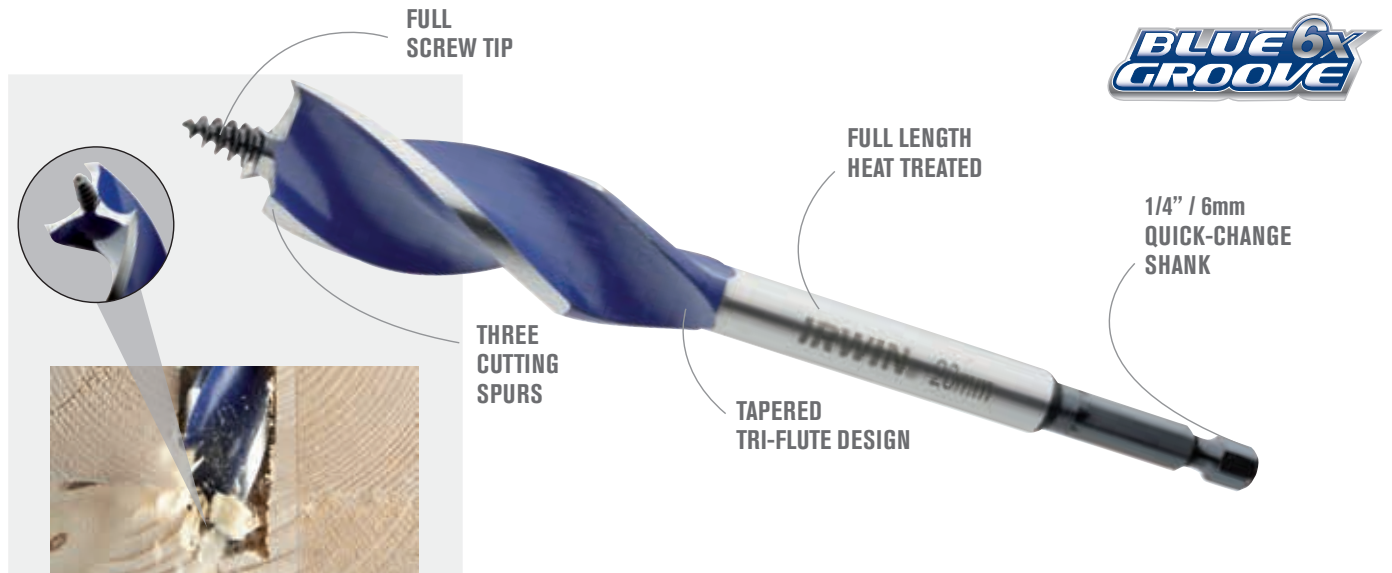

6 TIMES FASTER THAN STANDARD FLAT BITS



*Up to 6 times faster than competitor products



Quick Change Shank



Saves Battery Life



Wood

- 1. THREE CUTTING SPURS**
For clean holes with minimal break out
- 2. FULL SCREW TIP**
For easy pull through and added accuracy
- 3. TAPERED TRI-FLUTE DESIGN**
For faster chip ejection, less binding and ease of use
- 4. FULL LENGTH HEAT TREATED**
For extra durability
- 5. 1/4" / 6mm QUICK-CHANGE SHANK**
Reduces slipping in standard chucks and is compatible with 1/4" / 6mm quick-change chucks
- 6. MULTIPLE LENGTHS AVAILABLE - 4", 6" & 16"**
Short Length Bits for for drilling in tight spaces. Ideal for holes up to 2" (50mm) deep
Standard length bits ideal for holes up to 4" (100mm) deep
Extended length bits include hole in flute for easy wire pulling through walls, ceilings and floors

ALSO AVAILABLE IN SETS
SEE PAGE 138



| ITEM NO. | DESCRIPTION | EAN | MASTER PACK | SHELF PACK |
|-------------------------------------------|--------------------------------|---------------|-------------|------------|
| SHORT LENGTH BITS - 4" / 100mm | | | | |
| 1921930 | Blue Groove 6X 14mm x 4" Clam | 5706919219308 | 36 | 3 |
| 1921991 | Blue Groove 6X 16mm x 4" Clam | 5706919219919 | 36 | 3 |
| 1921992 | Blue Groove 6X 18mm x 4" Clam | 5706919219926 | 36 | 3 |
| 1921993 | Blue Groove 6X 20mm x 4" Clam | 5706919219933 | 36 | 3 |
| 1921994 | Blue Groove 6X 22mm x 4" Clam | 5706919219940 | 36 | 3 |
| 1921995 | Blue Groove 6X 25mm x 4" Clam | 5706919219957 | 36 | 3 |
| 1921996 | Blue Groove 6X 28mm x 4" Clam | 5706919219964 | 36 | 3 |
| 1921997 | Blue Groove 6X 32mm x 4" Clam | 5706919219971 | 36 | 3 |
| STANDARD LENGTH BITS - 6" / 165mm | | | | |
| 10507602 | Blue Groove 6X 14mm x 6" Clam | 5706915076028 | 36 | 6 |
| 10506620 | Blue Groove 6X 16mm x 6" Clam | 5706915066203 | 36 | 6 |
| 10506621 | Blue Groove 6X 18mm x 6" Clam | 5706915066210 | 36 | 6 |
| 10506622 | Blue Groove 6X 20mm x 6" Clam | 5706915066227 | 36 | 6 |
| 10506623 | Blue Groove 6X 22mm x 6" Clam | 5706915066234 | 36 | 6 |
| 10506624 | Blue Groove 6X 25mm x 6" Clam | 5706915066241 | 36 | 6 |
| 10506625 | Blue Groove 6X 28mm x 6" Clam | 5706915066258 | 36 | 6 |
| 10506626 | Blue Groove 6X 32mm x 6" Clam | 5706915066265 | 36 | 6 |
| EXTENDED LENGTH BITS - 16" / 400mm | | | | |
| 1921998 | Blue Groove 6X 14mm x 16" Clam | 5706919219988 | 36 | 3 |
| 1921999 | Blue Groove 6X 16mm x 16" Clam | 5706919219995 | 36 | 3 |
| 1922000 | Blue Groove 6X 18mm x 16" Clam | 5706919220007 | 36 | 3 |
| 1922001 | Blue Groove 6X 20mm x 16" Clam | 5706919220014 | 36 | 3 |
| 1922002 | Blue Groove 6X 22mm x 16" Clam | 5706919220021 | 36 | 3 |
| 1922003 | Blue Groove 6X 25mm x 16" Clam | 5706919220038 | 36 | 3 |
| 1922004 | Blue Groove 6X 28mm x 16" Clam | 5706919220045 | 36 | 3 |
| 1922005 | Blue Groove 6X 32mm x 16" Clam | 5706919220052 | 36 | 3 |

BLUE GROOVE 4X FLAT BITS



4 TIMES FASTER THAN STANDARD FLAT BITS



*Up to 4 times faster versus basic flat bits



Quick Change Shank



Saves Battery Life



Wood

- 1. DOUBLE CUTTING SPURS**
Scribe outside of the hole, reducing breakout
- 2. THICKER CUTTING EDGE**
For longer drilling life
- 3. BLUE GROOVE POINT & CUTTING EDGE**
For faster chip removal

- 4. 10% LARGER SHANK**
For added durability
- 5. 1/4" / 6mm HEX SHANK**
Prevents bit slipping in chuck

BLUE GROOVE 4X FLAT BITS - LENGTH 152mm

| ITEM NO. | DESCRIPTION | EAN | MASTER PACK | SHELF PACK |
|----------|-------------|---------------|-------------|------------|
| 10502803 | 6mm | 0024721013811 | 36 | 6 |
| 10502804 | 8mm | 0024721013828 | 36 | 6 |
| 10502805 | 10mm | 0024721013835 | 36 | 6 |
| 10502806 | 12mm | 0024721013842 | 36 | 6 |
| 10502807 | 13mm | 0024721013859 | 36 | 6 |
| 10502808 | 14mm | 0024721013866 | 36 | 6 |
| 10502809 | 16mm | 0024721013873 | 36 | 6 |
| 10502810 | 17mm | 0024721889171 | 36 | 6 |
| 10502811 | 18mm | 0024721013880 | 36 | 6 |
| 10502812 | 19mm | 0024721013897 | 36 | 6 |
| 10502813 | 20mm | 0024721013903 | 36 | 6 |
| 10502814 | 22mm | 0024721013910 | 36 | 6 |
| 10502815 | 24mm | 0024721013934 | 36 | 6 |
| 10502816 | 25mm | 0024721013941 | 36 | 6 |
| 10502817 | 26mm | 0024721013958 | 36 | 6 |
| 10502818 | 28mm | 0024721013965 | 36 | 3 |
| 10502819 | 30mm | 0024721013972 | 36 | 3 |
| 10502820 | 32mm | 0024721013989 | 36 | 3 |
| 10502821 | 35mm | 0024721014009 | 36 | 3 |
| 10502822 | 38mm | 0024721014016 | 36 | 3 |
| 10502823 | 40mm | 0024721889409 | 36 | 3 |



ALSO AVAILABLE IN SETS
SEE PAGE 138

10502813

BLUE GROOVE 4X FLAT BITS - LENGTH 400mm



| LONGER LENGTH for extended reach NOT FOR USE with bit extensions or drill presses | ITEM NO. | DESCRIPTION | EAN | MASTER PACK | SHELF PACK |
|--------------------------------------------------------------------------------------|----------|---------------|---------------|----------------|---------------|
| | 10502830 | 6mm | 0024721886064 | 36 | 6 |
| 10502831 | 8mm | 0024721886088 | 36 | 6 | |
| 10502832 | 10mm | 0024721013064 | 36 | 6 | |
| 10502833 | 12mm | 0024721014153 | 36 | 6 | |
| 10502834 | 13mm | 0024721014184 | 36 | 6 | |
| 10502835 | 14mm | 0024721013071 | 36 | 6 | |
| 10502836 | 16mm | 0024721014191 | 36 | 6 | |
| 10502837 | 18mm | 0024721014207 | 36 | 6 | |
| 10502838 | 19mm | 0024721013088 | 36 | 6 | |
| 10502839 | 20mm | 0024721014214 | 36 | 6 | |
| 10502840 | 22mm | 0024721014221 | 36 | 6 | |
| 10502842 | 25mm | 0024721014245 | 36 | 6 | |
| 10502843 | 28mm | 0024721014269 | 18 | 3 | |
| 10502844 | 30mm | 0024721014276 | 18 | 3 | |
| 10502845 | 32mm | 0024721014283 | 18 | 3 | |
| 10502846 | 35mm | 0024721014290 | 18 | 3 | |

BRAD POINT



SOLID CENTRE AUGER WITH CUTTING SPUR



| BRAD POINT TIP provides accurate positioning for starting the hole BIT IS PRECISION GROUND for use in furniture making, doweling, cabinetry and other woodworking applications where an exact hole size is required SPUR CUTTING EDGES reduce splintering and ensure a smooth, clean hole WIDE FLUTES provide a fast, continuous flow of chips | ITEM NO. | DIAMETER mm | WORKING LENGTH mm | TOTAL LENGTH mm | EAN | MASTER PACK | SHELF PACK |
|---------------------------------------------------------------------------------------------------------------------------------------------------------------------------------------------------------------------------------------------------------------------------------------------------------------------------------------------------------|----------|----------------|----------------------|--------------------|---------------|-------------|------------|
| | 10502792 | 3.0 | 37 | 67 | 5709131134534 | 200 | 10 |
| 10502793 | 4.0 | 52 | 88 | 5709131134558 | 200 | 10 | |
| 10502794 | 5.0 | 59 | 95 | 5709131134572 | 200 | 10 | |
| 10502795 | 6.0 | 67 | 103 | 5709131134596 | 200 | 10 | |
| 10502796 | 8.0 | 78 | 119 | 5709131134619 | 200 | 10 | |
| 10502797 | 10.0 | 87 | 136 | 5709131134633 | 200 | 10 | |
| 10502798 | 12.0 | 100 | 145 | 5709131134657 | 100 | 10 | |
| 10502799 | 13.0 | 104 | 149 | 5709131134671 | 100 | 10 | |
| 10502800 | 16.0 | 130 | 178 | 5709131134695 | 25 | 5 | |

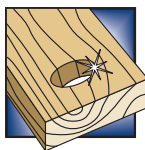







Perfect for all types of wood
Creates perfect and straight holes

LOCK-N-LOAD™ QUICK-CHANGE EXTENSIONS

6 TIMES FASTER THAN STANDARD FLAT BITS





LOCK-N-LOAD™ COMPATIBILITY

| 6,3 mm (1/4") | |
|-------------------------------------------------------------------------------------|--------------------------------|
|  | ALL POWER BITS |
|  | ALL INSERT BITS |
|  | ALL BLUE GROOVE 4X |
|  | ALL BLUE GROOVE 6X |
|  | BLUE GROOVE POWER 14 - 16mm |
|  | STEP DRILLS 1M - 2M |

LOCK-N-LOAD™ SYSTEM for one-handed quick release
JAW DESIGN holds bits securely on 6-flatted shanks, as well as ball detent bits
1/4" QUICK CHANGE RANGE now holds insert bits
CARBON STEEL CONSTRUCTION SLEEVE AND BODY for durability and life
LOCK-N-LOAD™ COMPATIBILITY



| 9,5 mm (3/8") | |
|-------------------------------------------------------------------------------------|--------------------------------|
|  | STEP DRILLS (SIZE 3M - 4M) |
|  | HOLE SAW ARBORS 9.5mm |
|  | BLUE GROOVE POWER 18 - 32mm |

| ITEM NO. | DESCRIPTION | EAN | MASTER PACK | SHELF PACK |
|----------|----------------------------------------------|---------------|-------------|------------|
| 10508166 | 1/4" Quick Change Bit Holder - 2,5" / 65 mm | 5706915081664 | 48 | 6 |
| 10508167 | 1/4" Quick Change Bit Holder - 6" / 150 mm | 5706915081671 | 48 | 6 |
| 10508168 | 1/4" Quick Change Bit Holder - 12" / 300 mm | 5706915081688 | 48 | 6 |
| 10508170 | 3/8" Quick Change Bit Holder - 5,5" / 140 mm | 5706915081701 | 24 | 3 |
| 10508171 | 3/8" Quick Change Bit Holder - 12" / 300 mm | 5706915081717 | 24 | 3 |



10508167

AUGER

SOLID CENTRE AUGER WITH CUTTING SPUR



The Original
AUGER

AUGER DRILL BITS

COARSE SCREW POINT for faster drilling into all types of wood
SINGLE SPUR DESIGN for smoother hole finish
EXTRA WIDE FLUTE for faster chip removal
FULLY HARDENED BODY from tip to shank for extra durability
HEX SHANK prevents bit slipping in chuck

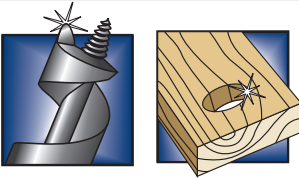

Perfect for all types of wood
 Creates perfect and straight holes



10502761

| ITEM NO. | DIAMETER mm | WORKING LENGTH mm | TOTAL LENGTH mm | HEX FACES mm | HEX FACES Inches | EAN | MASTER PACK | SHELF PACK |
|----------|-------------|-------------------|-----------------|--------------|------------------|---------------|-------------|------------|
| 10502738 | 5.0 | 73 | 150 | 3.9 | 5/32 | 5709131135579 | 24 | 1 |
| 10502739 | 6.0 | 114 | 191 | 4.8 | 3/16 | 5709131133490 | 24 | 1 |
| 10502740 | 6.0 | 323 | 400 | 4.8 | 3/16 | 5709131133957 | 24 | 1 |
| 10502741 | 8.0 | 114 | 191 | 5.6 | 7/32 | 5709131133513 | 24 | 1 |
| 10502742 | 8.0 | 323 | 400 | 5.6 | 7/32 | 5709131133971 | 24 | 1 |
| 10502744 | 10.0 | 114 | 191 | 7.9 | 5/16 | 5709131133537 | 24 | 1 |
| 10502745 | 10.0 | 323 | 400 | 7.9 | 5/16 | 5709131133995 | 24 | 1 |
| 10502747 | 11.0 | 114 | 191 | 7.9 | 5/16 | 5709131133551 | 24 | 1 |
| 10502748 | 12.0 | 114 | 191 | 7.9 | 5/16 | 5709131133575 | 24 | 1 |
| 10502749 | 12.0 | 323 | 400 | 7.9 | 5/16 | 5709131134015 | 24 | 1 |
| 10502751 | 13.0 | 114 | 191 | 7.9 | 5/16 | 5709131133599 | 24 | 1 |
| 10502752 | 13.0 | 323 | 400 | 7.9 | 5/16 | 5709131134039 | 24 | 1 |
| 10502754 | 14.0 | 126 | 191 | 7.9 | 5/16 | 5709131133612 | 24 | 1 |
| 10502755 | 14.0 | 335 | 400 | 7.9 | 5/16 | 5709131134053 | 24 | 1 |
| 10502756 | 15.0 | 126 | 191 | 7.9 | 5/16 | 5709131133636 | 24 | 1 |
| 10502757 | 16.0 | 126 | 191 | 7.9 | 5/16 | 5709131133650 | 24 | 1 |
| 10502758 | 16.0 | 335 | 400 | 7.9 | 5/16 | 5709131134077 | 24 | 1 |
| 10502760 | 17.0 | 126 | 191 | 7.9 | 5/16 | 5709131133674 | 24 | 1 |
| 10502761 | 18.0 | 126 | 191 | 7.9 | 5/16 | 5709131133698 | 24 | 1 |
| 10502762 | 18.0 | 335 | 400 | 7.9 | 5/16 | 5709131134091 | 24 | 1 |
| 10502764 | 19.0 | 126 | 191 | 7.9 | 5/16 | 5709131133711 | 24 | 1 |
| 10502765 | 19.0 | 335 | 400 | 7.9 | 5/16 | 5709131134114 | 24 | 1 |
| 10502766 | 20.0 | 126 | 191 | 7.9 | 5/16 | 5709131133735 | 24 | 1 |
| 10502767 | 20.0 | 335 | 400 | 7.9 | 5/16 | 5709131134138 | 24 | 1 |
| 10502769 | 22.0 | 126 | 191 | 7.9 | 5/16 | 5709131133759 | 24 | 1 |
| 10502770 | 22.0 | 335 | 400 | 7.9 | 5/16 | 5709131134152 | 24 | 1 |
| 10502772 | 24.0 | 126 | 191 | 7.9 | 5/16 | 5709131133773 | 24 | 1 |
| 10502773 | 24.0 | 335 | 400 | 7.9 | 5/16 | 5709131134176 | 24 | 1 |
| 10502774 | 25.0 | 126 | 191 | 7.9 | 5/16 | 5709131133797 | 24 | 1 |
| 10502775 | 25.0 | 335 | 400 | 7.9 | 5/16 | 5709131134190 | 24 | 1 |
| 10502776 | 26.0 | 126 | 191 | 11.1 | 7/16 | 5709131133810 | 24 | 1 |
| 10502777 | 26.0 | 335 | 400 | 11.1 | 7/16 | 5709131134213 | 24 | 1 |
| 10502778 | 28.0 | 175 | 240 | 11.1 | 7/16 | 5709131133834 | 24 | 1 |
| 10502779 | 28.0 | 335 | 400 | 11.1 | 7/16 | 5709131134237 | 24 | 1 |
| 10502780 | 30.0 | 175 | 240 | 11.1 | 7/16 | 5709131133858 | 24 | 1 |
| 10502781 | 30.0 | 335 | 400 | 11.1 | 7/16 | 5709131134251 | 16 | 1 |
| 10502782 | 32.0 | 175 | 240 | 11.1 | 7/16 | 5709131133872 | 24 | 1 |
| 10502783 | 32.0 | 335 | 400 | 11.1 | 7/16 | 5709131134275 | 16 | 1 |
| 10502784 | 35.0 | 175 | 240 | 11.1 | 7/16 | 5709131133896 | 24 | 1 |
| 10502785 | 35.0 | 335 | 400 | 11.1 | 7/16 | 5709131134312 | 16 | 1 |
| 10502786 | 36.0 | 335 | 400 | 11.1 | 7/16 | 5709131134336 | 16 | 1 |
| 10502787 | 38.0 | 175 | 240 | 11.1 | 7/16 | 5709131133919 | 24 | 1 |
| 10502788 | 40.0 | 175 | 240 | 11.1 | 7/16 | 5709131133933 | 24 | 1 |

AUGER DRILL BIT EXTENSIONS



10502790

| ITEM NO. | DESCRIPTION | EAN | MASTER PACK | SHELF PACK |
|----------|-----------------------------------------------------|---------------|-------------|------------|
| 10502789 | 5/16" / 7,9mm Extension 450mm for Auger Ø10 - 25mm | 5709131134756 | 25 | 5 |
| 10502790 | 7/16" / 11,1mm Extension 450mm for Auger Ø26 - 40mm | 5709131134756 | 25 | 5 |

MASONRY



SPEEDHAMMER™ POWER DRILL BIT SETS



10507538

| ITEM NO. | DESCRIPTION | EAN | MASTER PACK | SHELF PACK |
|----------|--------------------------------------------------------|---------------|-------------|------------|
| 10507538 | SPDH Power 9pc set: 6/6/8 x 110, 6/6/8/8/10/12 x 160mm | 5706915075380 | 6 | 1 |

SPEEDHAMMER™ PLUS DRILL BIT SETS



10502089



10507111

| ITEM NO. | DESCRIPTION | EAN | MASTER PACK | SHELF PACK |
|----------|-----------------------------------------------------------|---------------|-------------|------------|
| 10502089 | SPDH Plus 5pc set: 5/6/8/10/12 x 160mm | 5709131268871 | 48 | 16 |
| 10507110 | SPDH Plus 9pc set: 5/5,5/6 x 110, 5,5/6/6/8/10/12 x 160mm | 5706915071108 | 6 | 1 |
| 10507111 | SPDH Plus 9pc set: 5/6/6/8 x 110, 6/6/8/10/12 x 160mm | 5706915071115 | 6 | 1 |

SPEEDHAMMER™ PLUS DEMOLITION CHISELS



10502201

| ITEM NO. | DESCRIPTION | EAN | MASTER PACK | SHELF PACK |
|----------|---------------------------------------------------|---------------|-------------|------------|
| 10502201 | Demolition Chisels 3pc set: Pointed, Flat & Spade | 5709131285571 | - | 1 |



CORDLESS MULTI DRILL BIT CASSETTES

**CORDLESS
MULTI**



10501938



10501939



10501940

| ITEM NO. | DESCRIPTION | EAN | MASTER PACK | SHELF PACK |
|----------|-------------------------------------------|---------------|-------------|------------|
| 10501938 | Cordless Multi 5pc set: 4/5/6/8/10mm | 5709131247715 | 48 | 6 |
| 10501939 | Cordless Multi 5pc set: 5/5.5/6/8/10mm | 5709131247692 | 48 | 6 |
| 10501940 | Cordless Multi 7pc set: 4/5/6/7/8/10/12mm | 5709131247708 | 48 | 6 |

MASONRY DRILL BIT CASSETTES

MASONRY



10501892



10501893

| ITEM NO. | DESCRIPTION | EAN | MASTER PACK | SHELF PACK |
|----------|------------------------------------|---------------|-------------|------------|
| 10501892 | Masonry 5pc set: 4/5/6/8/10mm | 5709131248125 | 48 | 6 |
| 10501893 | Masonry 7pc set: 4/5/6/7/8/10/12mm | 5709131248149 | 48 | 6 |

GRANITE DRILL BIT CASSETTES

GRANITE



10501917



10501918

| ITEM NO. | DESCRIPTION | EAN | MASTER PACK | SHELF PACK |
|----------|------------------------------------|---------------|-------------|------------|
| 10501917 | Granite 5pc set: 4/5/6/8/10mm | 5709131248187 | 48 | 6 |
| 10501918 | Granite 7pc set: 4/5/6/7/8/10/12mm | 5709131248194 | 48 | 6 |

GLASS AND TILE DRILL BITS

GLASS & TILES



10507912

| ITEM NO. | DESCRIPTION | EAN | MASTER PACK | SHELF PACK |
|----------|-------------------------------------|---------------|-------------|------------|
| 10507912 | Glass & Tile 5 pc set: 4/5/6/8/11mm | 5706915079128 | 120 | 10 |

DIAMOND DRILL BITS

DIAMOND



10507900

| ITEM NO. | DESCRIPTION | EAN | MASTER PACK | SHELF PACK |
|----------|----------------------------|---------------|-------------|------------|
| 10507900 | Diamond 4pc set: 5/6/7/8mm | 5706915079005 | 60 | 1 |

TURBOMAX™ HSS DRILL BIT SETS

*TURBO
MAX*



10502234



10503992



10502233

| ITEM NO. | DESCRIPTION | EAN | MASTER PACK | SHELF PACK |
|----------|----------------------------------------------------------------------|---------------|-------------|------------|
| 10502234 | HSS Turbomax, 5pc set: 4/5/6/8/10mm | 5709131266167 | 48 | 6 |
| 10503992 | HSS Turbomax, 15pc set: 1,5 to 10,0mm | 5706915039924 | 6 | 1 |
| 10502233 | HSS Turbomax, 19pc set in metal case: 1,0 - 10,0mm in steps of 0,5mm | 5709131240693 | 5 | 1 |



METAL

HSS PRO COBALT DRILL BIT SETS



10502570



10503990



10502569



10503730

| ITEM NO. | DESCRIPTION | EAN | MASTER PACK | SHELF PACK |
|----------|--------------------------------------------------------------------|---------------|-------------|------------|
| 10502570 | HSS Cobalt, 5pc set: 4/5/6/8/10mm | 5709131282464 | 48 | 6 |
| 10503990 | HSS Cobalt, 15pc set: 1,5 to 10,0mm | 5706915039900 | 6 | 1 |
| 10502569 | HSS Cobalt, 19pc set in metal case: 1,0 - 10,0mm in steps of 0,5mm | 5709131282433 | 25 | 5 |
| 10503730 | HSS Cobalt, 25pc set in metal case: 1,0 - 13,0mm in steps of 0,5mm | 5706915037302 | 4 | 1 |

HSS TITANIUM DRILL BIT SETS



10502604



10503991



10502603

| ITEM NO. | DESCRIPTION | EAN | MASTER PACK | SHELF PACK |
|----------|----------------------------------------------------------------------|---------------|-------------|------------|
| 10502604 | HSS Titanium, 5pc set: 4/5/6/8/10mm | 5709131282471 | 48 | 6 |
| 10503991 | HSS Titanium, 15pc set: 1,5 to 10,0mm | 5706915039917 | 6 | 1 |
| 10502603 | HSS Titanium, 19pc set in metal case: 1,0 - 10,0mm in steps of 0,5mm | 5709131282440 | 25 | 5 |

HSS PRO DRILL BIT SETS



10502499



10503989



10502500



10502504

| ITEM NO. | DESCRIPTION | EAN | MASTER PACK | SHELF PACK |
|----------|-----------------------------------------------------------------|---------------|-------------|------------|
| 10502499 | HSS Pro, 5pc set: 4/5/6/8/10mm | 5709131282457 | 48 | 6 |
| 10503989 | HSS Pro, 15pc set: 1,5 to 10,0mm | 5706915039894 | 6 | 1 |
| 10502500 | HSS Pro, 19pc set in metal case: 1,0 - 10,0mm in steps of 0,5mm | 5709131284628 | 20 | 5 |
| 10502504 | HSS Pro, 25pc set in metal case: 1,0 - 13,0mm in steps of 0,5mm | 5709131284659 | 16 | 4 |

MIXED DRILL BIT SET



10503993

| ITEM NO. | DESCRIPTION | EAN | MASTER PACK | SHELF PACK |
|----------|-----------------------------------------------------------------------------------------------|---------------|-------------|------------|
| 10503993 | Combi, 15pc set: HSS Pro: 2/3/3,5/4/5/6/8mm; Cordless Multi: 4/5/6/8mm; Brad Point: 3/4/6/8mm | 5706915039931 | 6 | 1 |

BLUE GROOVE POWER WOOD BORING BIT SETS



10507720



10507764

| ITEM NO. | DESCRIPTION | EAN | MASTER PACK | SHELF PACK |
|----------|----------------------------------------|---------------|-------------|------------|
| 10507720 | Blue Groove Power, 3pc set: 14/16/18mm | 5706915077209 | 36 | 1 |
| 10507764 | Blue Groove Power, 3pc set: 20/22/25mm | 5706915077643 | 36 | 1 |



WOOD

BLUE GROOVE 6X WOOD BORING BIT SETS



10506627



10506628

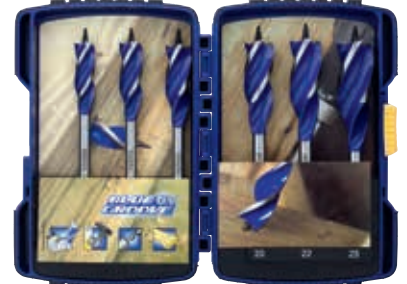

10507604

| ITEM NO. | DESCRIPTION | EAN | MASTER PACK | SHELF PACK |
|----------|----------------------------------------------|---------------|-------------|------------|
| 10506627 | Blue Groove 6X, 3pc set: 20/22/25mm | 5706915066272 | 6 | 1 |
| 10506628 | Blue Groove 6X, 6pc set: 16/18/20/22/25/32mm | 5706915066289 | 6 | 1 |
| 10507604 | Blue Groove 6X, 6pc set: 14/16/18/20/22/25mm | 5706915076042 | 6 | 1 |

BLUE GROOVE 4X FLAT DRILL BIT SETS



10502826



10506629



10507603

| ITEM NO. | DESCRIPTION | EAN | MASTER PACK | SHELF PACK |
|----------|----------------------------------------------------|---------------|-------------|------------|
| 10502826 | Blue Groove 4X, 6pc set: 10/13/16/19/22/25mm | 24721253149 | 6 | 1 |
| 10506629 | Blue Groove 4X, 8pc set: 12/16/18/20/22/25/28/32mm | 5706915066296 | 6 | 1 |
| 10507603 | Blue Groove 4X, 8pc set: 12/14/16/18/20/22/25/28mm | 5706915076035 | 6 | 1 |

FASTENER DRIVES & SCREWDRIVING



IMPACT PERFORMANCE SERIES™ FOR MAXIMUM DURABILITY AND LONG LIFE

Based on the increasing popularity and frequency of use of impact drivers on the jobsite, IRWIN® offers a broad range of impact fastener drive bits and accessories. While some screwdriving bits are simply compatible with impact drills and drivers, IRWIN® Impact Performance Series™ fastener drive bits are engineered for maximum durability and long life with impact drivers. These bits are designed with precision tip geometry so they fit fasteners more precisely, which reduces stripping and cam-out. Manufactured with heavy-duty, cold-forged, high-grade steel, they'll withstand extremely high torque output. Plus, a black oxide finish resists corrosion and increases the life of the bit.

DOUBLE-ENDED BITS

PRECISION TIP GEOMETRY

POWER GROOVE

BLACK OXIDE FINISH

DOUBLELOK TECHNOLOGY

PRECISION TIP
BETTER FIT. LESS STRIPPING.*

1923375

MANUFACTURED WITH HEAVY DUTY, HIGH-GRADE STEEL

IMPACT DOUBLE-ENDED BITS

- DOUBLELOK TECHNOLOGY**
Ensures both ends of the bit lock securely in impact drivers and quick-change chucks, enabling use of two tips from one bit for added convenience and extended life
- PRECISION TIP GEOMETRY**
Delivers superior fitment, reducing stripping and cam-out
- MANUFACTURED WITH HEAVY-DUTY, HIGH-GRADE STEEL**
To withstand high torque output
- BLACK OXIDE FINISH**
Resists corrosion and extends the life of the bit
- POWER GROOVE**
Designed for compatibility with IRWIN® Impact Performance Series™ Magnetic Screw-Hold Attachment



| ITEM NO. | DESCRIPTION | EAN | MASTER PACK | SHELF PACK |
|----------|---------------------------------------------------|---------------|-------------|------------|
| 1923372 | Impact Double-Ended Insert Bit - PH1 60mm - 2pcs | 5706919233724 | 25 | 5 |
| 1923373 | Impact Double-Ended Insert Bit - PH1 60mm - 10pcs | 5706919233731 | 60 | 10 |
| 1923375 | Impact Double-Ended Insert Bit - PH2 60mm - 2pcs | 5706919233755 | 25 | 5 |
| 1923376 | Impact Double-Ended Insert Bit - PH2 60mm - 10pcs | 5706919233762 | 60 | 10 |
| 1923377 | Impact Double-Ended Power Bit - PH2 100mm - 2pcs | 5706919233779 | 25 | 5 |
| 1923378 | Impact Double-Ended Insert Bit - PH3 60mm - 2pcs | 5706919233786 | 25 | 5 |
| 1923381 | Impact Double-Ended Insert Bit - T10 60mm - 2pcs | 5706919233816 | 25 | 5 |
| 1923383 | Impact Double-Ended Insert Bit - T15 60mm - 2pcs | 5706919233830 | 25 | 5 |
| 1923385 | Impact Double-Ended Insert Bit - T20 60mm - 2pcs | 5706919233854 | 25 | 5 |
| 1923386 | Impact Double-Ended Power Bit - T20 100mm - 2pcs | 5706919233861 | 25 | 5 |
| 1923387 | Impact Double-Ended Insert Bit - T25 60mm - 2pcs | 5706919233878 | 25 | 5 |
| 1923388 | Impact Double-Ended Power Bit - T25 100mm - 2pcs | 5706919233885 | 25 | 5 |
| 1923391 | Impact Double-Ended Insert Bit - T30 60mm - 2pcs | 5706919233915 | 25 | 5 |
| 1923392 | Impact Double-Ended Power Bit - T30 100mm - 2pcs | 5706919233922 | 25 | 5 |
| 1923405 | Impact Double-Ended Insert Bit - PZ1 60mm - 2pcs | 5706919234059 | 25 | 5 |
| 1923406 | Impact Double-Ended Insert Bit - PZ1 60mm - 10pcs | 5706919234066 | 60 | 10 |
| 1923407 | Impact Double-Ended Power Bit - PZ1 100mm - 2pcs | 5706919234073 | 25 | 5 |
| 1923408 | Impact Double-Ended Insert Bit - PZ2 60mm - 2pcs | 5706919234080 | 25 | 5 |
| 1923409 | Impact Double-Ended Insert Bit - PZ2 60mm - 10pcs | 5706919234097 | 60 | 10 |
| 1923410 | Impact Double-Ended Power Bit - PZ2 100mm - 2pcs | 5706919234103 | 25 | 5 |
| 1923411 | Impact Double-Ended Insert Bit - PZ3 60mm - 2pcs | 5706919234110 | 25 | 5 |
| 1923412 | Impact Double-Ended Insert Bit - PZ3 60mm - 10pcs | 5706919234127 | 60 | 10 |
| 1923227 | Impact Double-Ended Power Bit - PZ3 100mm - 2pcs | 5706919232277 | 25 | 5 |

Compatible with IRWIN® Impact Performance Series Magnetic Screw-Hold Attachment**

*vs. standard screwdriving bits **excludes T40, SL10-12, SL12-14, Hex 6 mm, Hex 8 mm, Hex 1/4"

FASTENER DRIVES & SCREWDRIVING

IMPACT SINGLE ENDED BITS

| ITEM NO. | DESCRIPTION | EAN | MASTER PACK | SHELF PACK |
|----------|-----------------------------------------------------------|---------------|-------------|------------|
| 1923286 | Impact Single-Ended Insert Bit - PH1 25mm - 2pcs | 5706919232864 | 25 | 5 |
| 1923287 | Impact Single-Ended Insert Bit - PH1 25mm - 10pcs | 5706919232871 | 25 | 5 |
| 1923289 | Impact Single-Ended Insert Bit - PH2 25mm - 2pcs | 5706919232895 | 25 | 5 |
| 1923290 | Impact Single-Ended Insert Bit - PH2 25mm - 10pcs | 5706919232901 | 25 | 5 |
| 1923322 | Impact Single-Ended Power Bit - PH2 50mm - 2pcs | 5706919233229 | 25 | 5 |
| 1923323 | Impact Single-Ended Insert Bit - PH3 25mm - 2pcs | 5706919233236 | 25 | 5 |
| 1923326 | Impact Single-Ended Insert Bit - T10 25mm - 2pcs | 5706919233267 | 25 | 5 |
| 1923328 | Impact Single-Ended Insert Bit - T15 25mm - 2pcs | 5706919233281 | 25 | 5 |
| 1923330 | Impact Single-Ended Insert Bit - T20 25mm - 2pcs | 5706919233304 | 25 | 5 |
| 1923332 | Impact Single-Ended Power Bit - T20 50mm - 2pcs | 5706919233328 | 25 | 5 |
| 1923333 | Impact Single-Ended Insert Bit - T25 25mm - 2pcs | 5706919233335 | 25 | 5 |
| 1923334 | Impact Single-Ended Power Bit - T25 50mm - 2pcs | 5706919233342 | 25 | 5 |
| 1923335 | Impact Single-Ended Insert Bit - T27 25mm - 2pcs | 5706919233359 | 25 | 5 |
| 1923337 | Impact Single-Ended Insert Bit - T30 25mm - 2pcs | 5706919233373 | 25 | 5 |
| 1923339 | Impact Single-Ended Power Bit - T30 50mm - 2pcs | 5706919233397 | 25 | 5 |
| 1923340 | Impact Single-Ended Insert Bit - T40 25mm - 2pcs | 5706919233403 | 25 | 5 |
| 1923342 | Impact Single-Ended Insert Bit - HEX3 25mm - 2pcs | 5706919233427 | 25 | 5 |
| 1923344 | Impact Single-Ended Insert Bit - HEX4 25mm - 2pcs | 5706919233441 | 25 | 5 |
| 1923346 | Impact Single-Ended Insert Bit - HEX5 25mm - 2pcs | 5706919233465 | 25 | 5 |
| 1923348 | Impact Single-Ended Insert Bit - HEX6 25mm - 2pcs | 5706919233489 | 25 | 5 |
| 1923350 | Impact Single-Ended Insert Bit - HEX8 25mm - 2pcs | 5706919233502 | 25 | 5 |
| 1923352 | Impact Single-Ended Insert Bit - P21 25mm - 2pcs | 5706919233526 | 25 | 5 |
| 1923353 | Impact Single-Ended Insert Bit - P21 25mm - 10pcs | 5706919233533 | 25 | 5 |
| 1923354 | Impact Single-Ended Power Bit - P21 50mm - 2pcs | 5706919233540 | 25 | 5 |
| 1923355 | Impact Single-Ended Insert Bit - P22 25mm - 2pcs | 5706919233557 | 25 | 5 |
| 1923356 | Impact Single-Ended Insert Bit - P22 25mm - 10pcs | 5706919233564 | 25 | 5 |
| 1923358 | Impact Single-Ended Power Bit - P22 50mm - 2pcs | 5706919233588 | 25 | 5 |
| 1923359 | Impact Single-Ended Insert Bit - P23 25mm - 2pcs | 5706919233595 | 25 | 5 |
| 1923360 | Impact Single-Ended Insert Bit - P23 25mm - 10pcs | 5706919233601 | 25 | 5 |
| 1923361 | Impact Single-Ended Power Bit - P23 50mm - 2pcs | 5706919233618 | 25 | 5 |
| 1923362 | Impact Single-Ended Insert Bit - SLOT 3mm - 25mm - 2pcs | 5706919233625 | 25 | 5 |
| 1923364 | Impact Single-Ended Insert Bit - SLOT 4.5mm - 25mm - 2pcs | 5706919233649 | 25 | 5 |
| 1923366 | Impact Single-Ended Insert Bit - SLOT 5.5mm - 25mm - 2pcs | 5706919233663 | 25 | 5 |
| 1923368 | Impact Single-Ended Insert Bit - SLOT 6.5mm - 25mm - 2pcs | 5706919233687 | 25 | 5 |
| 1923370 | Impact Single-Ended Insert Bit - SLOT 8mm - 25mm - 2pcs | 5706919233700 | 25 | 5 |

*vs. standard screwdriving bits **excludes T40, SL10-12, SL12-14, Hex 6 mm, Hex 8 mm & Hex 1/4"

PRECISION TIP GEOMETRY delivers superior fitment, reducing stripping and cam-out
MANUFACTURED WITH HEAVY-DUTY, HIGH-GRADE STEEL to withstand high torque output
POWER GROOVE designed for compatibility with IRWIN® Impact Performance Series™ Magnetic Screw-Hold Attachment



1923322

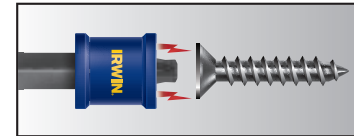
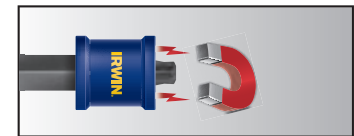
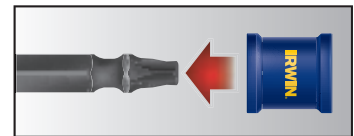

Compatible with IRWIN® Impact Performance Series Magnetic Screw-Hold Attachment**



BETTER FIT. LESS STRIPPING.*

20-PIECE PRO-PAK™ SETS

| ITEM NO. | DESCRIPTION | EAN | MASTER PACK | SHELF PACK |
|----------|---------------------------------------------------|---------------|-------------|------------|
| 1923321 | Impact Single-Ended Insert Bit - PH2 25mm - 20pcs | 5706919233321 | 10 | 1 |
| 1923331 | Impact Single-Ended Insert Bit - T20 25mm - 20pcs | 5706919233311 | 10 | 1 |
| 1923338 | Impact Single-Ended Insert Bit - T30 25mm - 20pcs | 5706919233380 | 10 | 1 |
| 1923357 | Impact Single-Ended Insert Bit - P22 25mm - 20pcs | 5706919233571 | 60 | 10 |



1923321

QUICK-CHANGE IMPACT BIT EXTENSIONS

Have a patented jaw design that is compatible with all 1/4" hex shank accessories including insert bits

| ITEM NO. | DESCRIPTION | EAN | MASTER PACK | SHELF PACK |
|----------|------------------------------------------------|---------------|-------------|------------|
| 1923502 | Impact Quick-Change Extension Bit - 2.5" - 1pc | 5706919235025 | 48 | 3 |
| 1923413 | Impact Quick-Change Extension Bit - 6" - 1pc | 5706919234134 | 48 | 3 |
| 1923414 | Impact Quick-Change Extension Bit - 12" - 1pc | 5706919234141 | 48 | 3 |



1923413

IMPACT BIT HOLDERS

Impact bit holders and attachments feature rare earth magnets which are four times more powerful than standard magnets to hold fasteners securely

| ITEM NO. | DESCRIPTION | EAN | MASTER PACK | SHELF PACK |
|----------|------------------------------------|---------------|-------------|------------|
| 1923228 | Impact Bit Holder - 3" - 1pc | 5706919232284 | 25 | 5 |
| 1923229 | Impact Bit Holder - 6" - 1pc | 5706919232291 | 25 | 5 |
| 1923501 | Impact Magnetic Screw Holder - 1pc | 5706919235018 | 25 | 5 |



1923228



1923501



IMPACT POCKET CASES

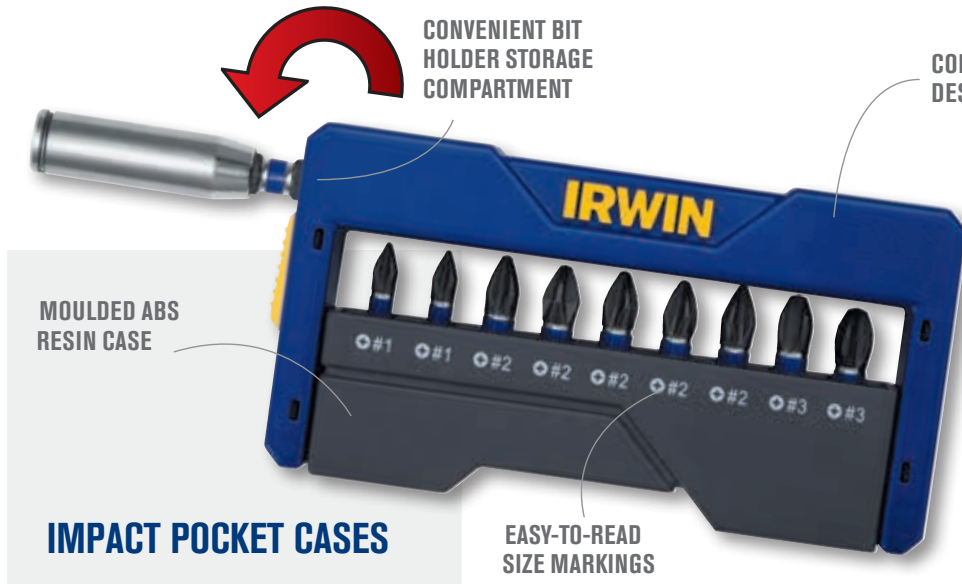

- 1. COMPACT, PORTABLE DESIGN**
Allows for easy transport to and from the worksite, and ease-of-use while on the job
- 2. MOULDED ABS RESIN CASE**
Moulded ABS resin case holds up to rigours of daily use
- 3. EASY-TO-READ SIZE MARKINGS**
Easy-to-read size markings provide simple identification of set contents
- 4. CONVENIENT BIT HOLDER STORAGE COMPARTMENT**
Incorporated into top of case I (insert bit cases only)

IMPACT POCKET CASES

IMPACT INSERT BIT 10 PIECE POCKET CASE SET

Holds (9) 1" insert bits and a bit holder



1923419

| ITEM NO. | DESCRIPTION | EAN | MASTER PACK | SHELF PACK |
|----------|---------------------------------------------------------------------------------------------|---------------|-------------|------------|
| 1923419 | Impact Insert Bit PH Set, 10pcs: 2 x PH1 / 5 x PH2 / 2 x PH3 + Bit Holder | 5706919234196 | 36 | 6 |
| 1923420 | Impact Insert Bit PZ Set, 10pcs: 2 x PZ1 / 5 x PZ2 / 2 x PZ3 + Bit Holder | 5706919234202 | 36 | 6 |
| 1923431 | Impact Insert Bit TX Set, 10pcs: T10 / 2 x T15 / 2 x T20 / 2 x T25 / T30 / T40 + Bit Holder | 5706919234318 | 36 | 6 |
| 1923432 | Impact Insert Bit Mixed Set, 10pcs: 4 x PZ2 / 4 x PH2 / T20 + Bit Holder | 5706919234325 | 36 | 6 |

IMPACT POWER BIT 5 PIECE POCKET CASE SET

Holds (5) 2" power bits



1923434

| ITEM NO. | DESCRIPTION | EAN | MASTER PACK | SHELF PACK |
|----------|------------------------------------------------------------------|---------------|-------------|------------|
| 1923433 | Impact Power Bit PZ / PH / TX Set, 5pcs: PZ2 x 2 / PH2 x 2 / T20 | 5706919234332 | 36 | 6 |
| 1923434 | Impact Power Bit PH Set, 5pcs: PH2 x 5 | 5706919234349 | 36 | 6 |
| 1923435 | Impact Power Bit PZ Set, 5pcs: PZ2 x 5 | 5706919234356 | 36 | 6 |

IMPACT POWER BIT 5 PIECE SET WITH MAGNETIC SCREW-HOLD ATTACHMENT



1923416

| ITEM NO. | DESCRIPTION | EAN | MASTER PACK | SHELF PACK |
|----------|------------------------------------------------------------------------|---------------|-------------|------------|
| 1923416 | Impact Power Bit PZ / PH Mag Set, 5pcs: 2 x PZ2 / 2 x PH2 plus 1903524 | 5706919234165 | 25 | 5 |
| 1923417 | Impact Power Bit PH Mag Set, 5pcs: 4 x PH2 plus 1903524 | 5706919234172 | 25 | 5 |
| 1923418 | Impact Power Bit PZ Mag Set, 5pcs: 4 x PZ2 plus 1903524 | 5706919234189 | 25 | 5 |

IMPACT PRO CASES



IMPACT PRO CASES

- 1. TWO-STEP EASY IN / OUT BIT STORAGE**
Holds bits securely in place until ready for use
- 2. MOULDED ABS RESIN CASE**
Moulded ABS resin case holds up to rigours of daily use
- 3. FULL-LENGTH METAL PIN IN HINGE**
For added durability and life
- 4. SECURE CLOSURE**
Easy-to-use sliding latch design keeps case securely closed when not in use

IMPACT BIT 22 PIECE PRO CASE SET

| ITEM NO. | DESCRIPTION | EAN | MASTER PACK | SHELF PACK |
|----------|-------------------------------------------------------------------------------------------|---------------|-------------|------------|
| 1923436 | PH1 X 2 / PH2 X 4 / PH3 X 1 / PZ1 X 2 / PZ2 X 4 / PZ3 X 1 / TX20 X 4 / TX30 X 3 / 1903524 | 5706919234363 | 6 | 1 |



IMPACT BIT 32 PIECE PRO CASE SET

| ITEM NO. | DESCRIPTION | EAN | MASTER PACK | SHELF PACK |
|----------|-----------------------------------------------------------------------------------------------------------------------------------------------------------------|---------------|-------------|------------|
| 1923437 | Insert Bits (25mm) - PH1 x 2 / PH2 x 3 / PH3 x 2 / PZ1 x 2 / PZ2 x 3 / PZ3 x 2 / TX20 x 3 / TX30 x 2 / TX25 x 2 Power Bit (50mm) - PH2 x 5 / PZ x 5 / 3" Holder | 5706919234370 | 6 | 1 |



SCREWDRIVING BITS

IRWIN® offers a full line of screwdriving bits designed for a number of applications. All bits are manufactured with industrial-grade S2 steel for long life and durability. Insert bits are engineered for use in hand-driving applications or with power tools when used with the IRWIN® insert bit holder. Power bits are specifically designed for the higher torque requirements of power tools. They are designed to provide more clearance between the power tool and the fastener.

PHILLIPS, INSERT BITS

| ITEM NO. | DESCRIPTION | EAN | MASTER PACK | SHELF PACK |
|-----------------------------------------------------------------------------------------------|-------------|-----------------------------------|---------------|------------|
|  10504388 | 10504387 | Phillips Ph1 - 1/4"/25mm - 2 pcs | 5706915043877 | 10 1 |
| | 10504388 | Phillips Ph2 - 1/4"/25mm - 2 pcs | 5706915043884 | 10 1 |
| | 10504389 | Phillips Ph3 - 1/4"/25mm - 2 pcs | 5706915043891 | 10 1 |
| | 10504390 | Phillips Ph1 - 1/4"/50mm - 2 pcs | 5706915043907 | 10 1 |
| | 10504391 | Phillips Ph2 - 1/4"/50mm - 2 pcs | 5706915043914 | 10 1 |
| | 10504396 | Phillips Ph2 - 1/4"/50mm - 5 pcs | 5706915043965 | 10 1 |
| | 10504330 | Phillips Ph1 - 1/4"/25mm - 10 pcs | 5706915043303 | 10 1 |
| | 10504331 | Phillips Ph2 - 1/4"/25mm - 10 pcs | 5706915043310 | 10 1 |
| | 10504332 | Phillips Ph3 - 1/4"/25mm - 10 pcs | 5706915043327 | 10 1 |

PHILLIPS, INSERT BITS - TITANIUM COATED

| ITEM NO. | DESCRIPTION | EAN | MASTER PACK | SHELF PACK |
|-------------------------------------------------------------------------------------------------|-------------|---------------------------------------|---------------|------------|
|  10504392 | 10504392 | Phillips Ph2 TiN - 1/4"/25mm - 2 pcs | 5706915043921 | 10 1 |
| | 10504333 | Phillips Ph1 TiN - 1/4"/25mm - 10 pcs | 5706915043334 | 10 1 |
| | 10504334 | Phillips Ph2 TiN - 1/4"/25mm - 10 pcs | 5706915043341 | 10 1 |
| | 10504335 | Phillips Ph3 TiN - 1/4"/25mm - 10 pcs | 5706915043358 | 10 1 |

PHILLIPS, POWER BITS

| ITEM NO. | DESCRIPTION | EAN | MASTER PACK | SHELF PACK |
|-------------------------------------------------------------------------------------------------|-------------|----------------------------------|---------------|------------|
|  10504396 | 10504395 | Phillips Ph1 - 1/4"/50mm - 2 pcs | 5706915043952 | 10 1 |
| | 10504396 | Phillips Ph2 - 1/4"/50mm - 2 pcs | 5706915043969 | 10 1 |
| | 10504363 | Phillips Ph1 - 1/4"/50mm - 5 pcs | 5706915043631 | 10 1 |
| | 10504364 | Phillips Ph2 - 1/4"/50mm - 5 pcs | 5706915043648 | 10 1 |
| | 10504365 | Phillips Ph2 - 1/4"/70mm - 1 pcs | 5706915043655 | 10 1 |
| | 10504366 | Phillips Ph2 - 1/4"/90mm - 1 pcs | 5706915043662 | 10 1 |
| | 10504367 | Phillips Ph3 - 1/4"/50mm - 5 pcs | 5706915043679 | 10 1 |

POZIDRIV, INSERT BITS

| ITEM NO. | DESCRIPTION | EAN | MASTER PACK | SHELF PACK |
|-------------------------------------------------------------------------------------------------|-------------|-----------------------------------|---------------|------------|
|  10504398 | 10504397 | Pozidriv Pz1 - 1/4"/25mm - 2 pcs | 5706915043976 | 10 1 |
| | 10504398 | Pozidriv Pz2 - 1/4"/25mm - 2 pcs | 5706915043983 | 10 1 |
| | 10504399 | Pozidriv Pz3 - 1/4"/25mm - 2 pcs | 5706915043990 | 10 1 |
| | 10504400 | Pozidriv Pz1 - 1/4"/50mm - 2 pcs | 5706915044003 | 10 1 |
| | 10504401 | Pozidriv Pz2 - 1/4"/50mm - 2 pcs | 5706915044010 | 10 1 |
| | 10504338 | Pozidriv Pz1 - 1/4"/25mm - 10 pcs | 5706915043389 | 10 1 |
| | 10504339 | Pozidriv Pz2 - 1/4"/25mm - 10 pcs | 5706915043396 | 10 1 |
| | 10504340 | Pozidriv Pz3 - 1/4"/25mm - 10 pcs | 5706915043402 | 10 1 |
| | 10504344 | Pozidriv Pz2 - 1/4"/50mm - 5 pcs | 5706915043440 | 10 1 |

POZIDRIV, INSERT BITS - TITANIUM COATED

| ITEM NO. | DESCRIPTION | EAN | MASTER PACK | SHELF PACK |
|-------------------------------------------------------------------------------------------------|-------------|---------------------------------------|---------------|------------|
|  10504402 | 10504402 | Pozidriv Pz2 TiN - 1/4"/25mm - 2 pcs | 5706915044027 | 10 1 |
| | 10504341 | Pozidriv Pz1 TiN - 1/4"/25mm - 10 pcs | 5706915043419 | 10 1 |
| | 10504342 | Pozidriv Pz2 TiN - 1/4"/25mm - 10 pcs | 5706915043426 | 10 1 |
| | 10504343 | Pozidriv Pz3 TiN - 1/4"/25mm - 10 pcs | 5706915043433 | 10 1 |

* Bulk packed products are priced per single item and can only be ordered in multiples of shelf pack quantity

FASTENER DRIVES & SCREWDRIVING

POZIDRIV, POWER BITS

| ITEM NO. | DESCRIPTION | EAN | MASTER PACK | SHELF PACK |
|----------|----------------------------------|---------------|-------------|------------|
| 10504406 | Pozidriv Pz2 - 1/4"/50mm - 2 pcs | 5706915044065 | 10 | 1 |
| 10504368 | Pozidriv Pz1 - 1/4"/50mm - 5 pcs | 5706915043686 | 50 | 1 |
| 10504369 | Pozidriv Pz2 - 1/4"/50mm - 5 pcs | 5706915043693 | 50 | 1 |
| 10504370 | Pozidriv Pz2 - 1/4"/70mm - 1 pcs | 5706915043709 | 10 | 1 |
| 10504371 | Pozidriv Pz2 - 1/4"/90mm - 1 pcs | 5706915043716 | 10 | 1 |
| 10504372 | Pozidriv Pz3 - 1/4"/50mm - 5 pcs | 5706915043723 | 10 | 1 |



PHILLIPS/POZIDRIV, DOUBLE-ENDED BITS

| ITEM NO. | DESCRIPTION | EAN | MASTER PACK | SHELF PACK |
|----------|--------------------------------------------|---------------|-------------|------------|
| 10504393 | Phillips Ph1/Ph2 - Double End 50mm - 2 pcs | 5706915043938 | 10 | 1 |
| 10504394 | Phillips Ph2/Ph2 - Double End 50mm - 2 pcs | 5706915043945 | 10 | 1 |
| 10504403 | Pozidriv Pz1/Pz2 - Double End 50mm - 2 pcs | 5706915044034 | 10 | 1 |
| 10504404 | Pozidriv Pz2/Pz2 - Double End 50mm - 2 pcs | 5706915044041 | 10 | 1 |



TORX, INSERT BITS

| ITEM NO. | DESCRIPTION | EAN | MASTER PACK | SHELF PACK |
|----------|-------------------------------|---------------|-------------|------------|
| 10504837 | Torx T15 - 1/4"/25mm - 2 pcs | 5706915048377 | 200 | 10 |
| 10504838 | Torx T20 - 1/4"/25mm - 2 pcs | 5706915048384 | 200 | 10 |
| 10504839 | Torx T25 - 1/4"/25mm - 2 pcs | 5706915048391 | 200 | 10 |
| 10504840 | Torx T30 - 1/4"/25mm - 2 pcs | 5706915048407 | 200 | 10 |
| 10504351 | Torx T10 - 1/4"/25mm - 10 pcs | 5706915043518 | 10 | 1 |
| 10504352 | Torx T15 - 1/4"/25mm - 10 pcs | 5706915043525 | 10 | 1 |
| 10504353 | Torx T20 - 1/4"/25mm - 10 pcs | 5706915043532 | 10 | 1 |
| 10504354 | Torx T25 - 1/4"/25mm - 10 pcs | 5706915043549 | 10 | 1 |
| 10504355 | Torx T27 - 1/4"/25mm - 10 pcs | 5706915043556 | 10 | 1 |
| 10504356 | Torx T30 - 1/4"/25mm - 10 pcs | 5706915043563 | 10 | 1 |
| 10504357 | Torx T40 - 1/4"/25mm - 10 pcs | 5706915043570 | 10 | 1 |



TORX, POWER BITS

| ITEM NO. | DESCRIPTION | EAN | MASTER PACK | SHELF PACK |
|----------|------------------------------|---------------|-------------|------------|
| 10504373 | Torx T20 - 1/4"/50mm - 5 pcs | 5706915043730 | 10 | 1 |
| 10504374 | Torx T25 - 1/4"/50mm - 5 pcs | 5706915043747 | 10 | 1 |
| 10504375 | Torx T30 - 1/4"/50mm - 5 pcs | 5706915043754 | 10 | 1 |
| 10504376 | Torx T40 - 1/4"/50mm - 5 pcs | 5706915043761 | 10 | 1 |



SLOTTED, INSERT BITS

| ITEM NO. | DESCRIPTION | EAN | MASTER PACK | SHELF PACK |
|----------|------------------------------------------|---------------|-------------|------------|
| 10504358 | Slotted 0,5 x 3,0mm - 1/4"/25mm - 10 pcs | 5706915043587 | 60 | 10 |
| 10504359 | Slotted 0,6 x 4,5mm - 1/4"/25mm - 10 pcs | 5706915043594 | 60 | 10 |
| 10504360 | Slotted 0,8 x 5,5mm - 1/4"/25mm - 10 pcs | 5706915043600 | 60 | 10 |
| 10504361 | Slotted 1,2 x 6,5mm - 1/4"/25mm - 10 pcs | 5706915043617 | 60 | 10 |
| 10504362 | Slotted 1,6 x 8,0mm - 1/4"/25mm - 10 pcs | 5706915043624 | 60 | 10 |



HEXAGONAL, INSERT BITS

| ITEM NO. | DESCRIPTION | EAN | MASTER PACK | SHELF PACK |
|----------|--------------------------------------|---------------|-------------|------------|
| 10504346 | Hexagonal 3,0mm - 1/4"/25mm - 10 pcs | 5706915043464 | 60 | 10 |
| 10504347 | Hexagonal 4,0mm - 1/4"/25mm - 10 pcs | 5706915043471 | 60 | 10 |
| 10504348 | Hexagonal 5,0mm - 1/4"/25mm - 10 pcs | 5706915043488 | 60 | 10 |
| 10504349 | Hexagonal 6,0mm - 1/4"/25mm - 10 pcs | 5706915043495 | 60 | 10 |
| 10504350 | Hexagonal 8,0mm - 1/4"/25mm - 10 pcs | 5706915043501 | 60 | 10 |



GRABIT JARS

| ITEM NO. | DESCRIPTION | EAN | MASTER PACK | SHELF PACK |
|----------|----------------------------------------------|---------------|-------------|------------|
| 10504383 | Grabit Jar Pozidriv Pz2 - 1/4"/25mm, 250 pcs | 5706915043839 | 4 | 1 |
| 10504384 | Grabit Jar Phillips Ph2 - 1/4"/25mm, 250 pcs | 5706915043846 | 4 | 1 |



POCKET CASES

CONVENIENT BIT HOLDER STORAGE COMPARTMENT

MOULDED ABS RESIN CASE

PORTABLE, DURABLE CASE THAT KEEPS BITS ORGANISED

IRWIN® Pocket Cases feature a compact, portable design that makes it simple to take the bits you need to get the job done. The convenient moulded ABS resin cases hold up to anything the jobsite can throw at them and include easy-to-read size markings for simple identification of the set contents. Plus, the 10-piece pocket case features an easy-to-access bit holder storage compartment right on top.



COMPACT, PORTABLE DESIGN

EASY-TO-READ SIZE MARKINGS

- 1. COMPACT, PORTABLE DESIGN**
Compact, portable design allows for easy transport to and from the worksite, and ease-of-use while on the job
- 2. MOULDED ABS RESIN CASE**
Moulded ABS resin case holds up to rigors of daily use
- 3. EASY-TO-READ SIZE MARKINGS**
Easy-to-read size markings provide simple identification of set contents
- 4. CONVENIENT BIT HOLDER STORAGE COMPARTMENT**
Incorporated into top of case (insert bit cases only)

SMALL POCKET CASES



1868194

| ITEM NO. | DESCRIPTION | EAN | MASTER PACK | SHELF PACK |
|----------|--------------------------------------------------------------------------------------|---------------|-------------|------------|
| 1868193 | IR 5PC PB Pocket Set (PH-PZ-TX): PB assorted, 5pc set: PH2 / PZ2 / T15 / T20 / T25 | 5706918681939 | - | 6 |
| 1868194 | IR 5PC PB Pocket Set (PH-PZ-SL): PB assorted, 5pc set: PH1 / PH2 / PZ1 / PZ2 / SL6.5 | 5706918681946 | - | 6 |

LARGE POCKET CASES



1868195

| ITEM NO. | DESCRIPTION | EAN | MASTER PACK | SHELF PACK |
|----------|-----------------------------------------------------------------------------------------------------------|---------------|-------------|------------|
| 1868195 | IR 10PC IB Pocket Set (PH): IB Philips, 10pc set: 2xPH1 / 5xPH2 / 2xPH3 + Bit Holder | 5706918681953 | - | 6 |
| 1868196 | IR 10PC IB Pocket Set (PZ): IB Pozidriv, 10pc set: 2xPZ1 / 5xPZ2 / 2xPZ3 + Bit Holder | 5706918681960 | - | 6 |
| 1868197 | IR 10PC IB Pocket Set (TX): IB Torx, 10pc set: T10/2xT15/2xT20/2xT25/T30/T40 + Bit Holder | 5706918681977 | - | 6 |
| 1868198 | IR 10PC IB Pocket Set (PH2-PZ2-T20): IB assorted, 10pc set: 4xPZ2 / 4xPH2 / T20 + Bit Holder | 5706918681984 | - | 6 |
| 1868199 | IR 10PC IB Pocket Set (PH-PZ-TX): IB assorted, 10pc set: PZ1/PZ2/PZ3/PH1/PH2/PH3/T15/T20/T25 + Bit Holder | 5706918681991 | - | 6 |
| 1868200 | IR 10PC IB Pocket Set (PH-PZ): IB assorted, 10pc set: PZ1 / 4xPZ2 / PZ3 / 3xPH2 + Bit Holder | 5706918682004 | - | 6 |

DRAWER CASES



COMPACT, EASY-TO-STORE CASE THAT CAN ORGANISE A WIDE VARIETY OF BITS

IRWIN® Drawer Cases feature a compact, flat design for enhanced portability and convenient storage in drawers and tool cabinets. The durable moulded ABS resin cases hold up to the daily rigors of shop-life and anything the jobsite can throw at them. The easy-to-read size markings make for simple identification of the set contents, and when not in use, the case stays securely closed with an easy-to-use sliding latch.

- 1. COMPACT, PORTABLE DESIGN**
Compact, flat design for convenient storage in drawers and tool cabinets
- 2. MOULDED ABS RESIN CASE**
Moulded ABS resin case holds up to rigors of daily use
- 3. EASY-TO-READ SIZE MARKINGS**
Easy-to-read size markings provide simple identification of set contents
- 4. SECURE CLOSURE**
Easy-to-use sliding latch design keeps case securely close when not in use

SMALL DRAWER CASES

| ITEM NO. | DESCRIPTION | EAN | MASTER PACK | SHELF PACK |
|----------|-----------------------------------------------------------------------------------------------------------------------------------------------------------------------------------|---------------|-------------|------------|
| 1868251 | IR 30PC SL DRAWER SET ASSORTED: IB assorted, 31pc small drawer case: PH1/2xPH2/PH3/PZ1/2xPZ2/PZ3/SL4-5/SL6-8/SL8-10/HEX4/HEX5/HEX6/2xT10/4xT15/4xT20/3xT25/2xT30/T40 + Bit Holder | 5706918682516 | - | 6 |

LARGE DRAWER CASES

| ITEM NO. | DESCRIPTION | EAN | MASTER PACK | SHELF PACK |
|----------|-----------------------------------------------------------------------------------------------------------------------------------------------------------------------------------------------------------------------------------------------------|---------------|-------------|------------|
| 1868252 | IR 58PC LG DRAWER SET ASSORTED: IB/PB assorted, 58pc large drawer case: 3xPH1/10xPH2/2xPH3/3xPZ1/10xPZ2/2xPZ3/SL3-4/SL4-5/SL6-8/SL8-10/HEX3/HEX4/HEX5/HEX6/2xT10/2xT15/2xT20/2xT25/2xT30/2xT40 + Powerbits PH2/PZ1/PZ2/PZ3/T15/T20/T25 + Bit Holder | 5706918682523 | - | 6 |



1868252



LARGE BIT SETS



10504385



10504386



10504382

| ITEM NO. | DESCRIPTION | EAN | MASTER PACK | SHELF PACK |
|----------|--------------------------------------------------------------------------------------------------------------------------------------------------------------------------|---------------|-------------|------------|
| 10504385 | SCB, 30pc set: PH1, 5xPH2, PH3, PZ1, 5xPZ2, PZ3, T20, T25, T30, T40, SL6-8, SL8-10, SL10-12, Nut Set: 6, 8, 10, 12, Double ends: PH2/PH2, PZ2/PZ1, 2xPZ2/PZ2, Bit Holder | 5706915043853 | 12 | 6 |
| 10504386 | SCB, 31pc set: PH1, 5xPH2, PH3, PZ1, 5xPZ2, PZ3, 2xPH2TiN, 2xPZ2TiN, SL6-8, SL8-10, SL10-12, Powerbits: 3xPH2, 3xPZ2, Double ends: PH2/PH2, PZ2/PZ1, PZ2/PZ2, Bit Holder | 5706915043860 | 12 | 6 |
| 10504382 | Bit Dispenser, 270pc set: PZ2 50mm, PZ1 50mm, PH2 50mm, PH1 50mm, 1/4" Bit Holder, PZ2 TiN, PZ3, PZ2, PZ1, PH2 TiN, PH3, PH2, PH1 | 5706915043822 | 4 | 1 |
| 1840465 | 21pcs Fastener Drive Set: 10x PH2, 5x SQ2, 5x SL8-10, Magnetic Drive Guide | 5706918404651 | 6 | 1 |

BIT HOLDERS



10504377



10504378



10504379



10504380



10504381

| ITEM NO. | DESCRIPTION | EAN | MASTER PACK | SHELF PACK |
|----------|---------------------------------------|---------------|-------------|------------|
| 10504377 | 50mm Magnetic Bit Holder 1/4" | 5706915043778 | 200 | 10 |
| 10504378 | 75mm Magnetic Bit Holder 1/4" | 5706915043785 | 200 | 10 |
| 10504379 | SDS Magnetic Bit Holder | 5706915043792 | 200 | 10 |
| 10504380 | Quick-Release Bit Holder 1/4" | 5706915043808 | 200 | 10 |
| 10504381 | 80mm Screw Drive Guide 9.5mm diameter | 5706915043815 | 200 | 10 |

BOLT-GRIP™ BOLT EXTRACTORS

Professionals don't waste time fighting rounded-off, rusted tight or painted-over bolts. They reach for the BOLT-GRIP. A unique, reverse spiral flute design securely grips and removes stubborn nuts and bolts.



54125



10504634



10504635



394100

| ITEM NO. | DESCRIPTION | EAN | MASTER PACK | SHELF PACK |
|----------|-------------------------------------------------------------------------------------------|---------------|-------------|------------|
| 10504634 | 5 Piece Base Set: 3/8", 7/16" (11mm), 1/2", 9/16" (14mm), 5/8" (16mm) | 0024721012579 | - | 5 |
| 10504635 | 5 Piece Expansion Set: 5/16" (8mm), 10mm, 13mm, 11/16", 3/4" (19mm) | 0024721016126 | - | 5 |
| 394100 | Powergrip Set: 3/16" - 1/2", 7 pcs | 0024721037633 | - | 5 |
| 54125 | 5 Piece Speciality Set: 3/4" (19mm), 13/16" (21mm), 7/8" (22mm), 15/16" (24mm), 1" (25mm) | 0024721541253 | - | 1 |
| 10504381 | 80mm Screw Drive Guide 9.5mm diameter | 5706915043815 | 200 | 10 |

MAXIMUM GRIPPING POWER reverse spiral flutes are designed to bite down
HIGH CARBON STEEL is tougher than tool steel, ensuring longer life and greater durability
WORKS WITH MOST TOOLS with a 3/8" square drive for use with hand ratchets, impact wrenches & air ratchets; hexagonal flats for use with flat wrench, pliers, adjustable wrench, sockets or VISE-GRIP® locking pliers
UNIVERSAL LOBULAR DESIGN fits all types of fasteners



IRWIN®



CIRCULAR SAW BLADES

IRWIN® now offers a comprehensive line-up of circular saw blades for professional tool users. From the jobsite, to the fine woodworking shop, IRWIN® offers a blade for every user need.

Marples®

At the heart of quality craftsmanship lies the rich heritage of Marples® woodworking tools. Originating in 1828 in Sheffield, England, the Marples® brand has consistently stood for superior performance and ultimate precision in fine woodworking.

Marples® is traditionally famous for chisels and synonymous with high-quality woodworking tools. The new range of Circular Saw Blades made in Udine, Italy uses best-in-class manufacturing capabilities and processes giving a range fitting of the Marples® brand.



The WeldTec™ platform redefines excellence with a range of construction saw blades that combines various attributes to deliver long lasting performance.

WeldTec Technology is the welding of teeth to the circular saw blade as opposed to the traditional brazing method. This is ideal for handheld corded and cordless blades as the weld provides a stronger tooth bond in case of unexpected nail strikes or foreign objects embedded in wood.



HAND-HELD

STATIONARY

CORDLESS

CORDED

MITRE

TABLE



ONLINE CIRCULAR SAW BLADE SELECTOR

Not sure which is the right blade for the job?

Visit: www.circularsawbladeselector.irwin.eu

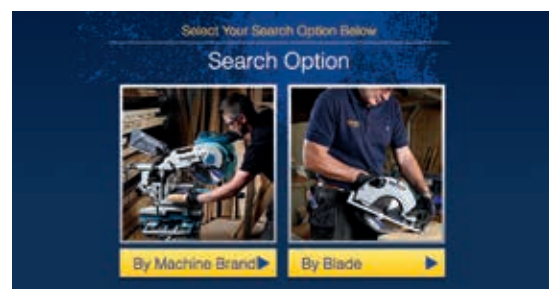

MARPLES® CIRCULAR SAW BLADES

LASER CUT BLADE BODY

PRECISION TENSIONING

EXTRA-SHARP, OVERSIZED CARBIDE TEETH

SPECIAL PTFE COATING WITH ALUMINIUM FLAKES

MARPLES® CIRCULAR SAW BLADES

PTFE NON-STICK
MADE IN ITALY PRODUCT

- EXTRA-SHARP, OVERSIZED CARBIDE TEETH**
Carbide is larger and tougher than standard carbide for 3X longer life and are re-sharpenable
- LASER CUT BLADE BODY**
For straighter, cleaner cuts
- PRECISION TENSIONING**
For greater accuracy
- SPECIAL PTFE COATING WITH ALUMINIUM FLAKES**
Helps to dissipate heat to prevent binding for smooth, cool cuts

1897459

| | ITEM NO. | DESCRIPTION | CATEGORY | MACHINES | DIAMETER | TOOTH COUNT | ARBOR/BORE | KERF THICKNESS | TOOTH CONFIG. | |
|----------------------------------|-----------------------------------------------------------------------------------------------------------------------------------------------------------------------|----------------|---------------|---------------|----------|-------------|------------|----------------|---------------|----------|
| TEETH GRIND CONFIGURATION | ATB ALTERNATE TOP BEVEL | | | | | | | | | |
| | | | | | | | | | | |
| | FEATURES | | | | | | | | | |
| | • Teeth alternate between a right- and left-hand bevel to form a knife-like edge on either side for a cleaner cut. | | | | | | | | | |
| | HI-ATB HIGH ALTERNATE TOP BEVEL | | | | | | | | | |
| | | | | | | | | | | |
| | FEATURES | | | | | | | | | |
| | • Used for extra-fine cross-cutting • High bevel angle increases the knife-like action at the edge of the blade | | | | | | | | | |
| | TCG TRIPLE CHIP GROUND | | | | | | | | | |
| | | | | | | | | | | |
| | FEATURES | | | | | | | | | |
| | • Excels at cutting hard materials like laminates, MDF, plastics and non-ferrous metals • Teeth alternate between a flat raking tooth and a trapezoid shaped tooth | | | | | | | | | |
| | | 1897453 | HPP 216mm/24T | Stationary | Mitre | 216 | 24 | 30 | 2.5 | ATB/N |
| | | 1897454 | HPP 216mm/48T | Stationary | Mitre | 216 | 48 | 30 | 2.5 | ATB/N |
| | | 1897455 | HPP 216mm/60T | Stationary | Mitre | 216 | 60 | 30 | 2.5 | ATB/N |
| | | 1897456 | HPP 250mm/48T | Stationary | Mitre | 250 | 48 | 30 | 2.5 | ATB/N |
| | | 1897457 | HPP 250mm/60T | Stationary | Mitre | 250 | 60 | 30 | 2.5 | ATB/N |
| | | 1897458 | HPP 250mm/80T | Stationary | Mitre | 250 | 80 | 30 | 2.5 | HI-ATB/N |
| | | 1897459 | HPP 254mm/48T | Stationary | Mitre | 254 | 48 | 30 | 2.5 | ATB/N |
| | | 1897460 | HPP 254mm/60T | Stationary | Mitre | 254 | 60 | 30 | 2.5 | ATB/N |
| | | 1897461 | HPP 254mm/80T | Stationary | Mitre | 254 | 80 | 30 | 2.5 | HI-ATB/N |
| | | 1897462 | HPP 260mm/48T | Stationary | Mitre | 260 | 48 | 30 | 2.5 | ATB/N |
| | | 1897463 | HPP 260mm/60T | Stationary | Mitre | 260 | 60 | 30 | 2.5 | ATB/N |
| | | 1897464 | HPP 260mm/80T | Stationary | Mitre | 260 | 80 | 30 | 2.5 | HI-ATB/N |
| | 1897465 | HPP 305mm/48T | Stationary | Mitre | 305 | 48 | 30 | 2.5 | ATB/N | |
| | 1897466 | HPP 305mm/60T | Stationary | Mitre | 305 | 60 | 30 | 2.5 | ATB/N | |
| | 1897467 | HPP 305mm/96T | Stationary | Mitre | 305 | 96 | 30 | 2.5 | HI-ATB/N | |
| | 1897474 | HPP 250mm/24T | Stationary | Table & Mitre | 250 | 24 | 30 | 3.2 | ATB | |
| | 1897475 | HPP 250mm/40T | Stationary | Table & Mitre | 250 | 40 | 30 | 3.2 | ATB | |
| | 1897476 | HPP 250mm/60T | Stationary | Table & Mitre | 250 | 60 | 30 | 3.2 | ATB | |
| | 1897477 | HPP 250mm/80T | Stationary | Table & Mitre | 250 | 80 | 30 | 3.2 | ATB | |
| | 1897478 | HPP 300mm/24T | Stationary | Table & Mitre | 300 | 24 | 30 | 3.2 | ATB | |
| | 1897479 | HPP 300mm/48T | Stationary | Table & Mitre | 300 | 48 | 30 | 3.2 | ATB | |
| | 1897480 | HPP 300mm/60T | Stationary | Table & Mitre | 300 | 60 | 30 | 3.2 | ATB | |
| | 1897468 | HPP 216mm/84T | Multi | Multi | 216 | 84 | 30 | 2.5 | TCG/N | |
| | 1897469 | HPP 250mm/84T | Multi | Multi | 250 | 84 | 30 | 2.5 | TCG/N | |
| | 1897470 | HPP 254mm/84T | Multi | Multi | 254 | 84 | 30 | 2.5 | TCG/N | |
| | 1897471 | HPP 260mm/84T | Multi | Multi | 260 | 84 | 30 | 2.5 | TCG/N | |
| | 1897472 | HPP 300mm/96T | Multi | Multi | 300 | 96 | 30 | 3.2 | TCG | |
| | 1897473 | HPP 305mm/100T | Multi | Multi | 305 | 100 | 30 | 2.5 | TCG/N | |

STATIONARY CIRCULAR SAW BLADES

CONSTRUCTION CIRCULAR SAW BLADES

| ITEM NO. | DESCRIPTION | CATEGORY | MACHINES | DIAMETER | TOOTH COUNT | ARBOR/BORE | KERF THICKNESS | TOOTH CONFIG. |
|----------|--------------------------|------------|-------------------------|----------|-------------|------------|----------------|---------------|
| 1897395 | Construction 216mm/24T M | Stationary | Mitre | 216 | 24 | 30 | 2.0 | ATB |
| 1897396 | Construction 216mm/48T M | Stationary | Mitre | 216 | 48 | 30 | 2.0 | ATB |
| 1897397 | Construction 216mm/60T M | Stationary | Mitre | 216 | 60 | 30 | 2.0 | ATB |
| 1897398 | Construction 250mm/48T M | Stationary | Mitre | 250 | 48 | 30 | 2.8 | ATB |
| 1897426 | Construction 250mm/60T M | Stationary | Mitre | 250 | 60 | 30 | 2.8 | ATB |
| 1897427 | Construction 250mm/80T M | Stationary | Mitre | 250 | 80 | 30 | 2.8 | ATB |
| 1897428 | Construction 254mm/48T M | Stationary | Mitre | 254 | 48 | 30 | 2.8 | ATB |
| 1897429 | Construction 254mm/60T M | Stationary | Mitre | 254 | 60 | 30 | 2.8 | ATB |
| 1897430 | Construction 254mm/80T M | Stationary | Mitre | 254 | 80 | 30 | 2.8 | ATB |
| 1897431 | Construction 260mm/48T M | Stationary | Mitre | 260 | 48 | 30 | 2.8 | ATB |
| 1897432 | Construction 260mm/60T M | Stationary | Mitre | 260 | 60 | 30 | 2.8 | ATB |
| 1897433 | Construction 260mm/80T M | Stationary | Mitre | 260 | 80 | 30 | 2.8 | ATB |
| 1897434 | Construction 305mm/48T M | Stationary | Mitre | 305 | 48 | 30 | 3.2 | ATB |
| 1897435 | Construction 305mm/60T M | Stationary | Mitre | 305 | 60 | 30 | 3.2 | ATB |
| 1897436 | Construction 305mm/80T M | Stationary | Mitre | 305 | 96 | 30 | 3.2 | ATB |
| 1897448 | Construction 250mm/24T | Stationary | Table & Mitre | 250 | 24 | 30 | 3.2 | ATB |
| 1897449 | Construction 250mm/40T | Stationary | Table & Mitre | 250 | 40 | 30 | 3.2 | ATB |
| 1897450 | Construction 250mm/60T | Stationary | Table & Mitre | 250 | 60 | 30 | 3.2 | ATB |
| 1897451 | Construction 300mm/48T | Stationary | Table & Mitre | 300 | 48 | 30 | 3.2 | ATB |
| 1897452 | Construction 300mm/60T | Stationary | Table & Mitre | 300 | 60 | 30 | 3.2 | ATB |
| 1897437 | MM CSB 160mm/48T | Multi | Handheld (corded) | 160 | 48 | 20 | 2 | TCG |
| 1897438 | MM CSB 165mm/48T | Multi | Handheld (corded) | 165 | 48 | 30 | 2 | TCG |
| 1897439 | MM CSB 184mm/48T | Multi | Handheld (corded) | 184 | 48 | 30 | 2 | TCG |
| 1897440 | MM CSB 190mm/48T | Multi | Handheld (corded) | 190 | 48 | 30 | 2 | TCG |
| 1897441 | MM CSB 210mm/84T | Multi | Handheld (corded)/Mitre | 210 | 60 | 30 | 3 | TCG |
| 1897442 | MM CSB 216mm/84T | Multi | Mitre | 216 | 84 | 30 | 3 | TCG |
| 1897443 | MM CSB 250mm/84T | Multi | Sliding Mitre/Mitre | 250 | 84 | 30 | 3 | TCG |
| 1897444 | MM CSB 254mm/84T | Multi | Sliding Mitre/Mitre | 254 | 84 | 30 | 3 | TCG |
| 1897445 | MM CSB 260mm/84T | Multi | Sliding Mitre/Mitre | 260 | 84 | 30 | 3 | TCG |
| 1897446 | MM CSB 300mm/96T | Multi | Table | 300 | 96 | 30 | 3 | TCG |
| 1897447 | MM CSB 305mm/84T | Multi | Sliding Mitre/Mitre | 305 | 84 | 30 | 3 | TCG |

CONSTRUCTION GRADE TUNGSTEN CARBIDE TIPS for longer life and are resharpenable
#400 GRIT DIAMOND GROUND TEETH for a smooth finish
EXPANSION SLOTS to dissipate heat and prevent warping
THIN KERF for fast cuts and longer motor life
CORROSION-RESISTANT COATING for longer, quality performance
ALTERNATE TOP BEVEL TOOTH CONFIGURATION (ATB) for cross cutting and ripping in all woods
TRIPLE CHIP GRIND TOOTH CONFIGURATION (TCG) for cutting hard materials like laminates, MDF, plastics and non-ferrous metals



1897448

GENERAL PURPOSE CIRCULAR SAW BLADES

| ITEM NO. | DESCRIPTION | CATEGORY | MACHINES | DIAMETER | TOOTH COUNT | ARBOR/BORE | KERF THICKNESS | TOOTH CONFIG. |
|----------|-----------------|------------|---------------|----------|-------------|------------|----------------|---------------|
| 1897209 | CSB 216mm/24T M | Stationary | Mitre | 216 | 48 | 30 | 2.5 | ATB |
| 1897210 | CSB 250mm/24T | Stationary | Table & Mitre | 250 | 24 | 30 | 3.0 | ATB |
| 1897211 | CSB 250mm/40T | Stationary | Table & Mitre | 250 | 40 | 30 | 3.0 | ATB |
| 1907700 | CSB 250mm/60T | Stationary | Table & Mitre | 250 | 60 | 30 | 3.0 | ATB |
| 1897212 | CSB 300mm/48T | Stationary | Table & Mitre | 300 | 48 | 30 | 3.2 | ATB |
| 1897213 | CSB 300mm/60T | Stationary | Table & Mitre | 300 | 60 | 30 | 3.2 | ATB |
| 1897214 | CSB 315mm/40T | Stationary | Table & Mitre | 315 | 40 | 30 | 3.2 | ATB |
| 1897215 | CSB 350mm/40T | Stationary | Table & Mitre | 350 | 40 | 30 | 3.5 | ATB |
| 1897346 | CSB 350mm/84T | Stationary | Table & Mitre | 350 | 84 | 30 | 3.5 | ATB |
| 1897347 | CSB 400mm/40T | Stationary | Table & Mitre | 400 | 40 | 30 | 3.8 | ATB |
| 1897348 | CSB 400mm/60T | Stationary | Table & Mitre | 400 | 60 | 30 | 3.8 | ATB |

BEST VALUE for an economy blade
PRECISION GROUND TEETH for smooth, accurate cuts
EXPANSION SLOTS for straighter cuts
CORROSION-RESISTANT COATING for longer, quality performance
ALTERNATE TOP BEVEL TOOTH CONFIGURATION (ATB) for cross cutting and ripping in all woods



1907700

IRWIN®

WELDTEC™



HAND-HELD & SPECIALITY CIRCULAR SAW BLADES

WELDTEC CIRCULAR SAW BLADES



WELDTEC CIRCULAR SAW BLADES



- 1. WELDED CARBIDE TEETH**
Up to 30% stronger tooth bond and for 50% longer life
- 2. ULTRA-COMPACT (UC2) CARBIDE**
70% tougher than standard carbide for superior sharpness and cut quality
- 3. INNOVATIVE HEAT VENTS & EXPANSION SLOTS**
For straighter cuts
- 4. FULLY HARDENED PLATE & REINFORCED SHOULDER**
For blade durability and truer, longer running with more accuracy
- 5. ALTERNATE TOP BEVEL (ATB) TOOTH CONFIGURATION**
For cross cutting and ripping in all woods

| SKU CODE | DESCRIPTION | CATEGORY | MACHINES | DIAMETER | TOOTH COUNT | ARBOR/BORE | REDUCTIONS | KERF THICKNESS | TOOTH CONFIG. |
|----------|----------------------------|----------|----------|----------|-------------|------------|------------|----------------|---------------|
| 1897349 | Weldtec CSB 150mm/24T | Handheld | Corded | 150 | 24 | 20 | 16 | 2.4 | ATB |
| 1897350 | Weldtec CSB 150mm/40T | Handheld | Corded | 150 | 40 | 20 | 16 | 2.4 | ATB |
| 1897361 | Weldtec CSB 160mm/18T | Handheld | Corded | 160 | 18 | 20 | 16 | 2.4 | ATB |
| 1897362 | Weldtec CSB 160mm/24T | Handheld | Corded | 160 | 24 | 20 | 16 | 2.4 | ATB |
| 1897363 | Weldtec CSB 160mm/40T | Handheld | Corded | 160 | 40 | 20 | 16 | 2.4 | ATB |
| 1897364 | Weldtec CSB 165mm/18T | Handheld | Corded | 165 | 18 | 30 | 20 | 2.4 | ATB |
| 1897365 | Weldtec CSB 165mm/24T | Handheld | Corded | 165 | 24 | 30 | 20 | 2.4 | ATB |
| 1897366 | Weldtec CSB 165mm/40T | Handheld | Corded | 165 | 40 | 30 | 20 | 2.4 | ATB |
| 1897368 | Weldtec CSB 184mm/24T AR30 | Handheld | Corded | 184 | 24 | 30 | 20 | 2.4 | ATB |
| 1897369 | Weldtec CSB 184mm/24T AR16 | Handheld | Corded | 184 | 24 | 16 | - | 2.4 | ATB |
| 1897370 | Weldtec CSB 184mm/40T AR30 | Handheld | Corded | 184 | 40 | 30 | 20 | 2.4 | ATB |
| 1897381 | Weldtec CSB 184mm/40T AR16 | Handheld | Corded | 184 | 40 | 16 | - | 2.4 | ATB |
| 1897382 | Weldtec CSB 190mm/18T | Handheld | Corded | 190 | 18 | 30 | 20 | 2.4 | ATB |
| 1897383 | Weldtec CSB 190mm/24T | Handheld | Corded | 190 | 24 | 30 | 20 | 2.4 | ATB |
| 1897384 | Weldtec CSB 190mm/40T | Handheld | Corded | 190 | 40 | 30 | 20 | 2.4 | ATB |
| 1897385 | Weldtec CSB 210mm/24T | Handheld | Corded | 210 | 24 | 30 | 20 | 2.4 | ATB |
| 1897386 | Weldtec CSB 210mm/40T | Handheld | Corded | 210 | 40 | 30 | 20 | 2.4 | ATB |
| 1897387 | Weldtec CSB 235mm/20T | Handheld | Corded | 235 | 20 | 30 | 20 | 2.4 | ATB |
| 1897388 | Weldtec CSB 235mm/40T | Handheld | Corded | 235 | 40 | 30 | 20 | 2.4 | ATB |
| 1897389 | Weldtec CSB 235mm/60T | Handheld | Corded | 235 | 60 | 30 | 20 | 2.4 | ATB |
| 1897390 | Weldtec CSB 136mm/18T C | Handheld | Cordless | 136 | 18 | 10 | - | 1.8 | ATB |
| 1897391 | Weldtec CSB 136mm/24T C | Handheld | Cordless | 136 | 24 | 10 | - | 1.8 | ATB |
| 1897392 | Weldtec CSB 165mm/18T C | Handheld | Cordless | 165 | 18 | 20 | 16 | 1.8 | ATB |
| 1897393 | Weldtec CSB 165mm/24T C | Handheld | Cordless | 165 | 24 | 20 | 16 | 1.8 | ATB |
| 1897394 | Weldtec CSB 165mm/40T C | Handheld | Cordless | 165 | 40 | 20 | 16 | 1.8 | ATB |

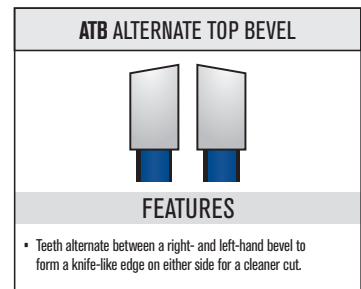

HAND-HELD CONSTRUCTION

THIN KERF WITH EVO ALTERNATING GRIND for fast cutting speed
HEAT VENTS & EXPANSION SLOTS reduce heat build-up and warping
CONSTRUCTION GRADE TUNGSTEN CARBIDE TIPS retain their edge and deliver longer life
CORROSION-RESISTANT COATING for longer, quality performance
ALTERNATE TOP BEVEL TOOTH CONFIGURATION (ATB) for cross cutting and ripping in all woods



1897200

| ITEM NO | DESCRIPTION | CATEGORY | MACHINES | DIAMETER | TOOTH COUNT | ARBOR/BORE | KERF THICKNESS | TOOTH CONFIG. |
|---------|-------------|----------|----------|----------|-------------|------------|----------------|---------------|
| 1897086 | 125mm/16T | Handheld | Corded | 125 | 16 | 20 | 2.5 | ATB |
| 1897087 | 130mm/20T | Handheld | Corded | 130 | 20 | 20 | 2.5 | ATB |
| 1897088 | 140mm/20T | Handheld | Corded | 140 | 20 | 20 | 2.5 | ATB |
| 1897089 | 150mm/18T | Handheld | Corded | 150 | 18 | 20 | 2.5 | ATB |
| 1897090 | 150mm/30T | Handheld | Corded | 150 | 30 | 20 | 2.5 | ATB |
| 1897191 | 160mm/18T | Handheld | Corded | 160 | 18 | 20 | 2.5 | ATB |
| 1897192 | 160mm/30T | Handheld | Corded | 160 | 30 | 20 | 2.5 | ATB |
| 1907698 | 160mm/24T | Handheld | Corded | 160 | 24 | 30 | 2.5 | ATB |
| 1897193 | 165mm/18T | Handheld | Corded | 165 | 18 | 30 | 2.5 | ATB |
| 1897194 | 165mm/30T | Handheld | Corded | 165 | 30 | 30 | 2.5 | ATB |
| 1897195 | 180mm/24T | Handheld | Corded | 180 | 24 | 30 | 2.5 | ATB |
| 1897196 | 180mm/36T | Handheld | Corded | 180 | 36 | 30 | 2.5 | ATB |
| 1907699 | 184mm/24T | Handheld | Corded | 184 | 24 | 16 | 2.5 | ATB |
| 1897197 | 184mm/24T | Handheld | Corded | 184 | 24 | 30 | 2.5 | ATB |
| 1897198 | 184mm/40T | Handheld | Corded | 184 | 40 | 30 | 2.5 | ATB |
| 1897199 | 190mm/24T | Handheld | Corded | 190 | 24 | 30 | 2.5 | ATB |
| 1897200 | 190mm/40T | Handheld | Corded | 190 | 40 | 30 | 2.5 | ATB |
| 1897201 | 200mm/24T | Handheld | Corded | 200 | 24 | 30 | 2.5 | ATB |
| 1897202 | 200mm/40T | Handheld | Corded | 200 | 40 | 30 | 2.5 | ATB |
| 1897203 | 210mm/20T | Handheld | Corded | 210 | 20 | 30 | 2.5 | ATB |
| 1897204 | 210mm/40T | Handheld | Corded | 210 | 40 | 30 | 2.5 | ATB |
| 1897205 | 230mm/24T | Handheld | Corded | 230 | 24 | 30 | 2.8 | ATB |
| 1897206 | 230mm/40T | Handheld | Corded | 230 | 40 | 30 | 2.8 | ATB |
| 1897207 | 235mm/20T | Handheld | Corded | 235 | 20 | 30 | 2.8 | ATB |
| 1897208 | 235mm/40T | Handheld | Corded | 235 | 40 | 30 | 2.8 | ATB |

SPECIALITY BLADES FOR NON-FERROUS METAL

EXPANSION SLOTS help keep the blade flat
TRIPLE CHIP GROUND TOOTH (TCG) for excellent finish of the cut
SPECIALLY DESIGNED for cutting all types of non-ferrous metals such as aluminium, copper, lead and plastics



1907778

| ITEM NO | DESCRIPTION | CATEGORY | MACHINES | DIAMETER | TOOTH COUNT | ARBOR/BORE | KERF THICKNESS | TOOTH CONFIG. |
|---------|--------------------------|------------|------------|----------|-------------|------------|----------------|---------------|
| 1907772 | Aluminium 160 x 56 x 20 | Speciality | Speciality | 160 | 56 | 20 | 2.5 | TCG |
| 1907773 | Aluminium 184 x 48 x 30 | Speciality | Speciality | 184 | 48 | 30 | 2.5 | TCG |
| 1907774 | Aluminium 200 x 60 x 30 | Speciality | Speciality | 200 | 60 | 30 | 2.5 | TCG |
| 1907775 | Aluminium 210 x 60 x 30 | Speciality | Speciality | 210 | 60 | 30 | 2.5 | TCG |
| 1907777 | Aluminium 216 x 60 x 30 | Speciality | Speciality | 216 | 60 | 30 | 2.5 | TCG |
| 1907778 | Aluminium 250 x 80 x 30 | Speciality | Speciality | 250 | 80 | 30 | 2.5 | TCG |
| 1907779 | Aluminium 250 x 100 x 30 | Speciality | Speciality | 250 | 100 | 30 | 2.5 | TCG |
| 1907781 | Aluminium 300 x 96 x 30 | Speciality | Speciality | 300 | 96 | 30 | 2.5 | TCG |
| 1907782 | Aluminium 350 x 84 x 30 | Speciality | Speciality | 350 | 84 | 30 | 2.5 | TCG |

CIRCULAR SAW BLADES

SELECTION CHART

| | DIAMETER | TOOTH | BORE | BLADE | SKU | HARDWOODS | SOFTWOODS | NAIL EMBEDDED | PLYWOOD | LAMINATED PLYWOOD | PARTICLE BOARD | DELICATE MOULDING | LAMINATES | BILAMINATE PANELS (DOUBLE-SIDED LAMINATES) | CONGLOMERATES (COMPOSITES) | MDF | MELAMINE | NON-FERROUS METALS (ALUMINUM) | PLASTICS | CORIAN |
|--------------------|----------|-------|---------|---------|---------|-----------|-----------|---------------|---------|-------------------|----------------|-------------------|-----------|--------------------------------------------|----------------------------|-----|----------|-------------------------------|----------|--------|
| | | | | | | | | | | | | | | | | | | | | |
| HANDHELD CORDED | 150mm | 24T | 20mm | WELDTEC | 1897349 | 5 | 5 | 5 | 5 | 3 | 5 | 2 | 3 | 3 | 4 | 4 | 2 | N/A | 4 | 2 |
| | 150mm | 30T | 20mm | IRWIN® | 1897090 | 4 | 4 | 2 | 4 | 2 | 4 | 1 | 2 | 2 | 3 | 3 | 1 | N/A | 3 | 1 |
| | 150mm | 40T | 20mm | WELDTEC | 1897350 | 5 | 5 | 5 | 5 | 3 | 5 | 2 | 3 | 3 | 4 | 4 | 2 | N/A | 4 | 2 |
| | 160mm | 18T | 20mm | IRWIN® | 1897191 | 4 | 4 | 2 | 4 | 2 | 4 | N/A | 2 | 2 | 3 | 3 | 1 | N/A | 3 | 1 |
| | | | | WELDTEC | 1897361 | 5 | 5 | 5 | 5 | 3 | 5 | 2 | 3 | 3 | 4 | 4 | 2 | N/A | 4 | 2 |
| | 160mm | 24T | 30mm | IRWIN® | 1907698 | 4 | 4 | 4 | 4 | 2 | 4 | 1 | 2 | 2 | 3 | 3 | 1 | N/A | 3 | 1 |
| | | | | WELDTEC | 1897362 | 5 | 5 | 5 | 5 | 3 | 5 | 2 | 3 | 3 | 4 | 4 | 2 | N/A | 4 | 2 |
| | 160mm | 30T | 20mm | IRWIN® | 1897192 | 4 | 4 | 2 | 4 | 2 | 4 | 1 | 2 | 2 | 3 | 3 | 1 | N/A | 3 | 1 |
| | 160mm | 40T | 20mm | WELDTEC | 1897363 | 5 | 5 | 5 | 5 | 3 | 5 | 2 | 3 | 3 | 4 | 4 | 2 | N/A | 4 | 2 |
| | 165mm | 18T | 30mm | IRWIN® | 1897193 | 4 | 4 | 2 | 4 | 2 | 4 | N/A | 2 | 2 | 3 | 3 | 1 | N/A | 3 | 1 |
| | | | | WELDTEC | 1897364 | 5 | 5 | 5 | 5 | 3 | 5 | 2 | 3 | 3 | 4 | 4 | 2 | N/A | 4 | 2 |
| | 165mm | 30T | 30mm | IRWIN® | 1897194 | 4 | 4 | 2 | 4 | 2 | 4 | 1 | 2 | 2 | 3 | 3 | 1 | N/A | 3 | 1 |
| | 165mm | 40T | 30mm | WELDTEC | 1897366 | 5 | 5 | 5 | 5 | 3 | 5 | 2 | 3 | 3 | 4 | 4 | 2 | N/A | 4 | 2 |
| | 180mm | 24T | 30mm | IRWIN® | 1897195 | 4 | 4 | 2 | 4 | 2 | 4 | N/A | 2 | 2 | 3 | 3 | 1 | N/A | 3 | 1 |
| | 180mm | 36T | 30mm | IRWIN® | 1897196 | 4 | 4 | 2 | 4 | 2 | 4 | 1 | 2 | 2 | 3 | 3 | 1 | N/A | 3 | 1 |
| | 184mm | 24T | 16mm | IRWIN® | 1907699 | 4 | 4 | 2 | 4 | 2 | 4 | N/A | 2 | 2 | 3 | 3 | 1 | N/A | 3 | 1 |
| | | | | WELDTEC | 1897369 | 5 | 5 | 5 | 5 | 3 | 5 | 2 | 3 | 3 | 4 | 4 | 2 | N/A | 4 | 2 |
| | 184mm | 24T | 30mm | IRWIN® | 1897197 | 4 | 4 | 2 | 4 | 2 | 4 | N/A | 2 | 2 | 3 | 3 | 1 | N/A | 3 | 1 |
| | | | | WELDTEC | 1897368 | 5 | 5 | 5 | 5 | 3 | 5 | 2 | 3 | 3 | 4 | 4 | 2 | N/A | 4 | 2 |
| | 184mm | 40T | 16mm | WELDTEC | 1897381 | 5 | 5 | 5 | 5 | 3 | 5 | 2 | 3 | 3 | 4 | 4 | 2 | N/A | 4 | 2 |
| | 184mm | 40T | 30mm | IRWIN® | 1897198 | 4 | 4 | 2 | 4 | 2 | 4 | 1 | 2 | 2 | 3 | 3 | 1 | N/A | 3 | 1 |
| | | | | WELDTEC | 1897370 | 5 | 5 | 5 | 5 | 3 | 5 | 2 | 3 | 3 | 4 | 4 | 2 | N/A | 4 | 2 |
| | 190mm | 18T | 30mm | WELDTEC | 1897382 | 5 | 5 | 5 | 5 | 3 | 5 | 2 | 3 | 3 | 4 | 4 | 2 | N/A | 4 | 2 |
| | 190mm | 24T | 30mm | IRWIN® | 1897199 | 4 | 4 | 2 | 4 | 2 | 4 | 1 | 2 | 2 | 3 | 3 | 1 | N/A | 3 | 1 |
| | | | | WELDTEC | 1897383 | 5 | 5 | 5 | 5 | 3 | 5 | 2 | 3 | 3 | 4 | 4 | 2 | N/A | 4 | 2 |
| | 190mm | 40T | 30mm | IRWIN® | 1897200 | 4 | 4 | 2 | 4 | 2 | 4 | 1 | 2 | 2 | 3 | 3 | 1 | N/A | 3 | 1 |
| | | | | WELDTEC | 1897384 | 5 | 5 | 5 | 5 | 3 | 5 | 2 | 3 | 3 | 4 | 4 | 2 | N/A | 4 | 2 |
| | 200mm | 24T | 30mm | IRWIN® | 1897201 | 4 | 4 | 2 | 4 | 2 | 4 | N/A | 2 | 2 | 3 | 3 | 1 | N/A | 3 | 1 |
| | 200mm | 40T | 30mm | IRWIN® | 1897202 | 4 | 4 | 2 | 4 | 2 | 4 | 1 | 2 | 2 | 3 | 3 | 1 | N/A | 3 | 1 |
| | 210mm | 20T | 30mm | IRWIN® | 1897203 | 4 | 4 | 2 | 4 | 2 | 4 | N/A | 2 | 2 | 3 | 3 | 1 | N/A | 3 | 1 |
| | 210mm | 24T | 30mm | WELDTEC | 1897385 | 5 | 5 | 5 | 5 | 3 | 5 | 2 | 3 | 3 | 4 | 4 | 2 | N/A | 4 | 2 |
| | 210mm | 40T | 30mm | IRWIN® | 1897204 | 4 | 4 | 2 | 4 | 2 | 4 | 1 | 2 | 2 | 3 | 3 | 1 | N/A | 3 | 1 |
| | | | | WELDTEC | 1897386 | 5 | 5 | 5 | 5 | 3 | 5 | 2 | 3 | 3 | 4 | 4 | 2 | N/A | 4 | 2 |
| | 235mm | 20T | 30mm | WELDTEC | 1897387 | 5 | 5 | 5 | 5 | 3 | 5 | 2 | 3 | 3 | 4 | 4 | 2 | N/A | 4 | 2 |
| | 230mm | 24T | 30mm | IRWIN® | 1897205 | 4 | 4 | 2 | 4 | 2 | 4 | N/A | 2 | 2 | 3 | 3 | 1 | N/A | 3 | 1 |
| | 230mm | 40T | 30mm | IRWIN® | 1897206 | 4 | 4 | 2 | 4 | 2 | 4 | 1 | 2 | 2 | 3 | 3 | 1 | N/A | 3 | 1 |
| WELDTEC | | | | 1897388 | 5 | 5 | 5 | 5 | 3 | 5 | 2 | 3 | 3 | 4 | 4 | 2 | N/A | 4 | 2 | |
| 235mm | 40T | 30mm | WELDTEC | 1897389 | 5 | 5 | 5 | 5 | 3 | 5 | 2 | 3 | 3 | 4 | 4 | 2 | N/A | 4 | 2 | |
| CORDLESS | 136mm | 18T | 10mm | WELDTEC | 1897390 | 5 | 5 | 5 | 5 | 3 | 5 | 2 | 3 | 3 | 4 | 4 | 2 | N/A | 4 | 2 |
| | 136mm | 24T | 10mm | WELDTEC | 1897391 | 5 | 5 | 5 | 5 | 3 | 5 | 2 | 3 | 3 | 4 | 4 | 2 | N/A | 4 | 2 |
| | 165mm | 18T | 20mm | WELDTEC | 1897392 | 5 | 5 | 5 | 5 | 3 | 5 | 2 | 3 | 3 | 4 | 4 | 2 | N/A | 4 | 2 |
| | 165mm | 24T | 20mm | WELDTEC | 1897393 | 5 | 5 | 5 | 5 | 3 | 5 | 2 | 3 | 3 | 4 | 4 | 2 | N/A | 4 | 2 |
| 165mm | 40T | 20mm | WELDTEC | 1897394 | 5 | 5 | 5 | 5 | 3 | 5 | 2 | 3 | 3 | 4 | 4 | 2 | N/A | 4 | 2 | |

RATING SCALE: (1=FAIR, 3=GOOD, 5=BEST)

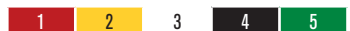

SELECTION CHART

| | | DIAMETER | TOOTH | BORE | BLADE | SKU | HARDWOODS | SOFTWOODS | NAIL EMBEDDED | PLYWOOD | LAMINATED PLYWOOD | PARTICLE BOARD | DELICATE MOULDING | LAMINATES | BILAMINATE PANELS (DOUBLE-SIDED LAMINATES) | CONGLOMERATES (COMPOSITES) | MDF | MELAMINE | NON-FERROUS METALS (ALUMINUM) | PLASTICS | CORIAN | |
|------------|---------|----------|--------------|---------|--------------|---------|-----------|-----------|---------------|---------|-------------------|----------------|-------------------|-----------|--------------------------------------------|----------------------------|-----|----------|-------------------------------|----------|--------|---|
| STATIONARY | TABLE | 235mm | 20T | 30mm | IRWIN® | 1897207 | 4 | 4 | 2 | 4 | 2 | 4 | N/A | 2 | 2 | 3 | 3 | 1 | N/A | 3 | 1 | |
| | | 235mm | 40T | 30mm | IRWIN® | 1897208 | 4 | 4 | 2 | 4 | 2 | 4 | 1 | 2 | 2 | 3 | 3 | 1 | N/A | 3 | 1 | |
| | | 250mm | 24T | 30mm | IRWIN® | 1897210 | 4 | 4 | 2 | 4 | 2 | 4 | N/A | 2 | 2 | 3 | 3 | 1 | N/A | 3 | 3 | |
| | | | | | Construction | 1897448 | 5 | 5 | 2 | 5 | 2 | 5 | 2 | 5 | 2 | 2 | 2 | 4 | 4 | 1 | N/A | 3 |
| | | | | | MARPLES® | 1897474 | 5 | 5 | 2 | 5 | 2 | 5 | N/A | 2 | 2 | 4 | 4 | 1 | N/A | 3 | 3 | |
| | | 250mm | 40T | 30mm | IRWIN® | 1897211 | 4 | 4 | 2 | 4 | 2 | 4 | N/A | 2 | 2 | 3 | 3 | 1 | N/A | 3 | 3 | |
| | | | | | Construction | 1897449 | 5 | 5 | 2 | 5 | 2 | 5 | 3 | 2 | 2 | 4 | 4 | 1 | N/A | 3 | 3 | |
| | | | | | MARPLES® | 1897475 | 5 | 5 | 2 | 5 | 2 | 5 | 3 | 2 | 2 | 4 | 4 | 1 | N/A | 3 | 3 | |
| | | 250mm | 60T | 30mm | IRWIN® | 1907700 | 3 | 3 | 1 | 3 | 1 | 3 | 3 | 3 | 1 | 1 | 3 | 3 | N/A | N/A | 2 | 2 |
| | | | | | Construction | 1897450 | 4 | 4 | 2 | 4 | 2 | 4 | 4 | 2 | 4 | 4 | 2 | 4 | 4 | 1 | N/A | 3 |
| | | | | | MARPLES® | 1897476 | 5 | 5 | 2 | 5 | 2 | 5 | 4 | 2 | 2 | 4 | 4 | 1 | N/A | 3 | 3 | |
| | | 250mm | 80T | 30mm | MARPLES® | 1897477 | 5 | 5 | 2 | 5 | 2 | 5 | 5 | 2 | 2 | 4 | 4 | 1 | N/A | 3 | 3 | |
| | | 300mm | 24T | 30mm | MARPLES® | 1897478 | 5 | 5 | 2 | 5 | 2 | 5 | N/A | 2 | 2 | 4 | 4 | 1 | N/A | 3 | 3 | |
| | | 300mm | 48T | 30mm | IRWIN® | 1897212 | 4 | 4 | 2 | 4 | 2 | 4 | N/A | 2 | 2 | 3 | 3 | 1 | N/A | 3 | 3 | |
| | | | | | Construction | 1897451 | 5 | 5 | 2 | 5 | 2 | 5 | 3 | 2 | 2 | 4 | 4 | 1 | N/A | 3 | 3 | |
| | | | | | MARPLES® | 1897479 | 5 | 5 | 2 | 5 | 2 | 5 | 3 | 2 | 2 | 4 | 4 | 1 | N/A | 3 | 3 | |
| | | 300mm | 60T | 30mm | IRWIN® | 1897213 | 4 | 4 | 2 | 4 | 2 | 4 | N/A | 2 | 2 | 3 | 3 | 1 | N/A | 3 | 3 | |
| | | | | | Construction | 1897452 | 5 | 5 | 2 | 5 | 2 | 5 | 4 | 2 | 2 | 4 | 4 | 1 | N/A | 3 | 3 | |
| | | | | | MARPLES® | 1897480 | 5 | 5 | 2 | 5 | 2 | 5 | 4 | 2 | 2 | 4 | 4 | 1 | N/A | 3 | 3 | |
| | | 315mm | 40T | 30mm | IRWIN® | 1897214 | 4 | 4 | 2 | 4 | 2 | 4 | N/A | 2 | 2 | 3 | 3 | 1 | N/A | 3 | 3 | |
| 350mm | 40T | 30mm | IRWIN® | 1897215 | 4 | 4 | 2 | 4 | 2 | 4 | N/A | 2 | 2 | 3 | 3 | 1 | N/A | 3 | 3 | | | |
| 350mm | 84T | 30mm | IRWIN® | 1897346 | 4 | 4 | 2 | 4 | 2 | 4 | N/A | 2 | 2 | 3 | 3 | 1 | N/A | 3 | 3 | | | |
| 400mm | 40T | 30mm | IRWIN® | 1897347 | 4 | 4 | 2 | 4 | 2 | 4 | N/A | 2 | 2 | 3 | 3 | 1 | N/A | 3 | 3 | | | |
| 400mm | 60T | 30mm | IRWIN® | 1897348 | 4 | 4 | 2 | 4 | 2 | 4 | N/A | 2 | 2 | 4 | 4 | 1 | N/A | 3 | 3 | | | |
| MITRE | TABLE | 216mm | 24T | 30mm | Construction | 1897395 | 5 | 5 | 1 | 5 | 3 | 4 | 1 | 3 | 2 | 4 | 4 | 2 | N/A | 4 | 2 | |
| | | | | | MARPLES® | 1897453 | 5 | 5 | 1 | 5 | 3 | 4 | 1 | 3 | 2 | 4 | 5 | 2 | N/A | 4 | 2 | |
| | | | | | IRWIN® | 1897209 | 4 | 4 | 2 | 4 | 2 | 3 | 1 | 2 | 2 | 3 | 3 | 1 | N/A | 3 | 1 | |
| | | 216mm | 48T | 30mm | Construction | 1897396 | 5 | 5 | 1 | 5 | 3 | 4 | 3 | 3 | 2 | 4 | 4 | 2 | N/A | 4 | 2 | |
| | | | | | MARPLES® | 1897454 | 5 | 5 | 1 | 5 | 3 | 4 | 4 | 3 | 2 | 4 | 5 | 2 | N/A | 4 | 2 | |
| | | 216mm | 60T | 30mm | Construction | 1897397 | 5 | 5 | 1 | 5 | 3 | 4 | 4 | 3 | 2 | 4 | 4 | 2 | N/A | 4 | 2 | |
| | | | | | MARPLES® | 1897455 | 5 | 5 | 1 | 5 | 3 | 4 | 5 | 3 | 2 | 4 | 5 | 2 | N/A | 4 | 2 | |
| | | 250mm | 48T | 30mm | Construction | 1897398 | 5 | 5 | 1 | 5 | 3 | 4 | 2 | 3 | 2 | 4 | 4 | 2 | N/A | 4 | 2 | |
| | | | | | MARPLES® | 1897456 | 5 | 5 | 1 | 5 | 3 | 4 | 3 | 3 | 2 | 4 | 5 | 2 | N/A | 4 | 2 | |
| | | 250mm | 60T | 30mm | Construction | 1897426 | 5 | 5 | 1 | 5 | 3 | 4 | 3 | 3 | 2 | 4 | 4 | 2 | N/A | 4 | 2 | |
| | | | | | MARPLES® | 1897457 | 5 | 5 | 1 | 5 | 3 | 4 | 4 | 3 | 2 | 4 | 5 | 2 | N/A | 4 | 2 | |
| | | 250mm | 80T | 30mm | Construction | 1897427 | 5 | 5 | 1 | 5 | 3 | 4 | 4 | 3 | 2 | 4 | 4 | 2 | N/A | 4 | 2 | |
| | | | | | MARPLES® | 1897458 | 5 | 5 | 1 | 5 | 3 | 4 | 5 | 3 | 2 | 4 | 5 | 2 | N/A | 4 | 2 | |
| | | 254mm | 48T | 30mm | Construction | 1897428 | 5 | 5 | 1 | 5 | 3 | 4 | 2 | 3 | 2 | 4 | 4 | 2 | N/A | 4 | 2 | |
| | | | | | MARPLES® | 1897459 | 5 | 5 | 1 | 5 | 3 | 4 | 3 | 3 | 2 | 4 | 5 | 2 | N/A | 4 | 2 | |
| | | 254mm | 60T | 30mm | Construction | 1897429 | 5 | 5 | 1 | 5 | 3 | 4 | 3 | 3 | 2 | 4 | 4 | 2 | N/A | 4 | 2 | |
| | | | | | MARPLES® | 1897460 | 5 | 5 | 1 | 5 | 3 | 4 | 4 | 3 | 2 | 4 | 5 | 2 | N/A | 4 | 2 | |
| | | 254mm | 80T | 30mm | Construction | 1897430 | 5 | 5 | 1 | 5 | 3 | 4 | 4 | 3 | 2 | 4 | 4 | 2 | N/A | 4 | 2 | |
| | | | | | MARPLES® | 1897461 | 5 | 5 | 1 | 5 | 3 | 4 | 5 | 3 | 2 | 4 | 5 | 2 | N/A | 4 | 2 | |
| | | 260mm | 48T | 30mm | Construction | 1897431 | 5 | 5 | 1 | 5 | 3 | 4 | 2 | 3 | 2 | 4 | 4 | 2 | N/A | 4 | 2 | |
| MARPLES® | 1897462 | | | | 5 | 5 | 1 | 5 | 3 | 4 | 3 | 3 | 2 | 4 | 5 | 2 | N/A | 4 | 2 | | | |
| 260mm | 60T | 30mm | Construction | 1897432 | 5 | 5 | 1 | 5 | 3 | 4 | 3 | 3 | 2 | 4 | 4 | 2 | N/A | 4 | 2 | | | |
| | | | MARPLES® | 1897463 | 5 | 5 | 1 | 5 | 3 | 4 | 3 | 3 | 2 | 4 | 5 | 2 | N/A | 4 | 2 | | | |
| 260mm | 80T | 30mm | Construction | 1897433 | 5 | 5 | 1 | 5 | 3 | 4 | 4 | 3 | 2 | 4 | 4 | 2 | N/A | 4 | 2 | | | |
| | | | MARPLES® | 1897464 | 5 | 5 | 1 | 5 | 3 | 4 | 4 | 3 | 2 | 4 | 5 | 2 | N/A | 4 | 2 | | | |
| 305mm | 48T | 30mm | Construction | 1897434 | 5 | 5 | 1 | 5 | 3 | 4 | 2 | 3 | 2 | 4 | 4 | 2 | N/A | 4 | 2 | | | |
| | | | MARPLES® | 1897465 | 5 | 5 | 1 | 5 | 3 | 4 | 3 | 3 | 2 | 4 | 5 | 2 | N/A | 4 | 2 | | | |
| 305mm | 60T | 30mm | Construction | 1897435 | 5 | 5 | 1 | 5 | 3 | 4 | 3 | 3 | 2 | 4 | 4 | 2 | N/A | 4 | 2 | | | |
| | | | MARPLES® | 1897466 | 5 | 5 | 1 | 5 | 3 | 4 | 4 | 3 | 2 | 4 | 5 | 2 | N/A | 4 | 2 | | | |
| 305mm | 96T | 30mm | Construction | 1897436 | 5 | 5 | 1 | 5 | 3 | 4 | 4 | 3 | 2 | 4 | 4 | 2 | N/A | 4 | 2 | | | |
| | | | MARPLES® | 1897467 | 5 | 5 | 1 | 5 | 3 | 4 | 5 | 3 | 2 | 4 | 5 | 2 | N/A | 4 | 2 | | | |

CIRCULAR SAW BLADES

SELECTION CHART

| | | DIAMETER | TOOTH | BORE | BLADE | SKU | HARDWOODS | SOFTWOODS | NAIL EMBEDDED | PLYWOOD | LAMINATED PLYWOOD | PARTICLE BOARD | DELICATE MOULDING | LAMINATES | BILAMINATE PANELS (DOUBLE-SIDED LAMINATES) | CONGLOMERATES (COMPOSITES) | MDF | MELAMINE | NON-FERROUS METALS (ALUMINIUM) | PLASTICS | CORIAN |
|------------|-------|-------------------|-----------|-------|--------------|---------|-----------|-----------|---------------|---------|-------------------|----------------|-------------------|-----------|--------------------------------------------|----------------------------|-----|----------|--------------------------------|----------|--------|
| STATIONARY | MULTI | 160mm | 48T | 20mm | Construction | 1897437 | 4 | 3 | 2 | 3 | 4 | 3 | 5 | 5 | 4 | 4 | 4 | 5 | 4 | 4 | 5 |
| | | 165mm | 48T | 30mm | Construction | 1897438 | 4 | 3 | 2 | 3 | 4 | 3 | 5 | 5 | 4 | 4 | 4 | 5 | 4 | 4 | 5 |
| | | 184mm | 48T | 30mm | Construction | 1897439 | 4 | 3 | 2 | 3 | 4 | 3 | 5 | 5 | 4 | 4 | 4 | 5 | 4 | 4 | 5 |
| | | 190mm | 48T | 30mm | Construction | 1897440 | 4 | 3 | 2 | 3 | 4 | 3 | 5 | 5 | 4 | 4 | 4 | 5 | 4 | 4 | 5 |
| | | 210mm | 60T | 30mm | Construction | 1897441 | 4 | 3 | 2 | 3 | 4 | 3 | 5 | 5 | 4 | 4 | 4 | 5 | 4 | 4 | 5 |
| | | 216mm | 84T | 30mm | Construction | 1897442 | 4 | 3 | 2 | 3 | 4 | 3 | 5 | 5 | 4 | 4 | 4 | 5 | 4 | 4 | 5 |
| | | | | | MARPLES® | 1897468 | 4 | 3 | 2 | 3 | 4 | 3 | 5 | 5 | 4 | 4 | 4 | 5 | 4 | 4 | 5 |
| | | 250mm | 84T | 30mm | Construction | 1897443 | 4 | 3 | 2 | 3 | 4 | 3 | 5 | 5 | 4 | 4 | 4 | 5 | 4 | 4 | 5 |
| | | | | | MARPLES® | 1897469 | 4 | 3 | 2 | 3 | 4 | 3 | 5 | 5 | 4 | 4 | 4 | 5 | 4 | 4 | 5 |
| | | 254mm | 84T | 30mm | Construction | 1897444 | 4 | 3 | 2 | 3 | 4 | 3 | 5 | 5 | 4 | 4 | 4 | 5 | 4 | 4 | 5 |
| | | | | | MARPLES® | 1897470 | 4 | 3 | 2 | 3 | 4 | 3 | 5 | 5 | 4 | 4 | 4 | 5 | 4 | 4 | 5 |
| | | 260mm | 84T | 30mm | Construction | 1897445 | 4 | 3 | 2 | 3 | 4 | 3 | 5 | 5 | 4 | 4 | 4 | 5 | 4 | 4 | 5 |
| | | | | | MARPLES® | 1897471 | 4 | 3 | 2 | 3 | 4 | 3 | 5 | 5 | 4 | 4 | 4 | 5 | 4 | 4 | 5 |
| | | 300mm | 96T | 30mm | Construction | 1897446 | 4 | 3 | 2 | 3 | 4 | 3 | 5 | 5 | 4 | 4 | 4 | 5 | 4 | 4 | 5 |
| | | | | | MARPLES® | 1897472 | 4 | 3 | 2 | 3 | 4 | 3 | 5 | 5 | 4 | 4 | 4 | 5 | 4 | 4 | 5 |
| | | 305mm | 84T | 30mm | Construction | 1897447 | 4 | 3 | 2 | 3 | 4 | 3 | 5 | 5 | 4 | 4 | 4 | 5 | 4 | 4 | 5 |
| | | | | | MARPLES® | 1897473 | 4 | 3 | 2 | 3 | 4 | 3 | 5 | 5 | 4 | 4 | 4 | 5 | 4 | 4 | 5 |
| | | MATERIAL SPECIFIC | ALUMINIUM | 160mm | 56T | 20mm | IRWIN® | 1907772 | N/A | N/A | N/A | N/A | N/A | N/A | N/A | N/A | N/A | N/A | N/A | N/A | 5 |
| 184mm | 48T | | | 30mm | IRWIN® | 1907773 | N/A | N/A | N/A | N/A | N/A | N/A | N/A | N/A | N/A | N/A | N/A | N/A | 5 | N/A | N/A |
| 200mm | 60T | | | 30mm | IRWIN® | 1907774 | N/A | N/A | N/A | N/A | N/A | N/A | N/A | N/A | N/A | N/A | N/A | N/A | 5 | N/A | N/A |
| 210mm | 60T | | | 30mm | IRWIN® | 1907775 | N/A | N/A | N/A | N/A | N/A | N/A | N/A | N/A | N/A | N/A | N/A | N/A | 5 | N/A | N/A |
| 216mm | 60T | | | 30mm | IRWIN® | 1907777 | N/A | N/A | N/A | N/A | N/A | N/A | N/A | N/A | N/A | N/A | N/A | N/A | 5 | N/A | N/A |
| 250mm | 80T | | | 30mm | IRWIN® | 1907778 | N/A | N/A | N/A | N/A | N/A | N/A | N/A | N/A | N/A | N/A | N/A | N/A | 5 | N/A | N/A |
| 250mm | 100T | | | 30mm | IRWIN® | 1907779 | N/A | N/A | N/A | N/A | N/A | N/A | N/A | N/A | N/A | N/A | N/A | N/A | 5 | N/A | N/A |
| 300mm | 96T | | | 30mm | IRWIN® | 1907781 | N/A | N/A | N/A | N/A | N/A | N/A | N/A | N/A | N/A | N/A | N/A | N/A | 5 | N/A | N/A |
| 250mm | 84T | | | 30mm | IRWIN® | 1907782 | N/A | N/A | N/A | N/A | N/A | N/A | N/A | N/A | N/A | N/A | N/A | N/A | 5 | N/A | N/A |

RATING SCALE: (1=FAIR, 3=GOOD, 5=BEST)

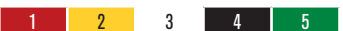

IRWIN®



LONG ESTABLISHED MANUFACTURING EXCELLENCE LEADS TO PERFECTION

IRWIN® manufactures and distributes high quality cutting tools for trade professionals who demand superior performance and durability on the job. Our engineers have been working for almost over a century on constant product improvement, resulting in a state-of-the-art in-house electron beam welding process to create the highest quality bi-metal blades that out-perform the competition, stay sharper and last longer.

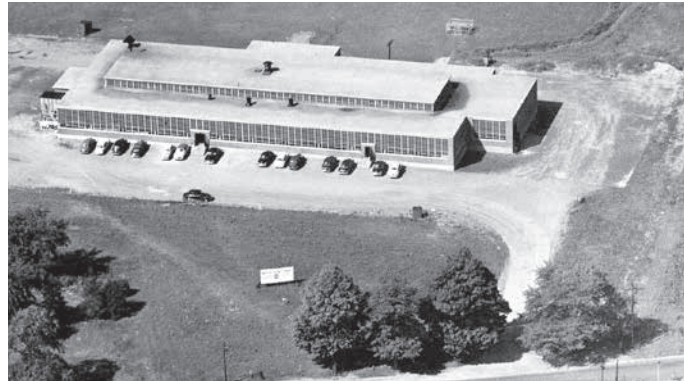

The WeldTec™ platform combines various attributes to deliver long lasting cutting performance. A revolutionary tooth geometry and an updated tooth set enables faster and smoother cuts, as well as improved longevity.

HOLE SAWS



RECIPROCATING BLADES



JIGSAW BLADES



BI-METAL HOLE SAWS

IRWIN® Bi-Metal Hole Saws cut through a variety of materials, including: Aluminium, Copper, Iron, Stainless Steel, Wood and Zinc.

The electron beam welded High Speed Steel (HSS) cutting edge ensures stronger, longer lasting teeth. Precision set teeth provide faster penetration and cutting. And, the bi-metal construction delivers toughness and long life.

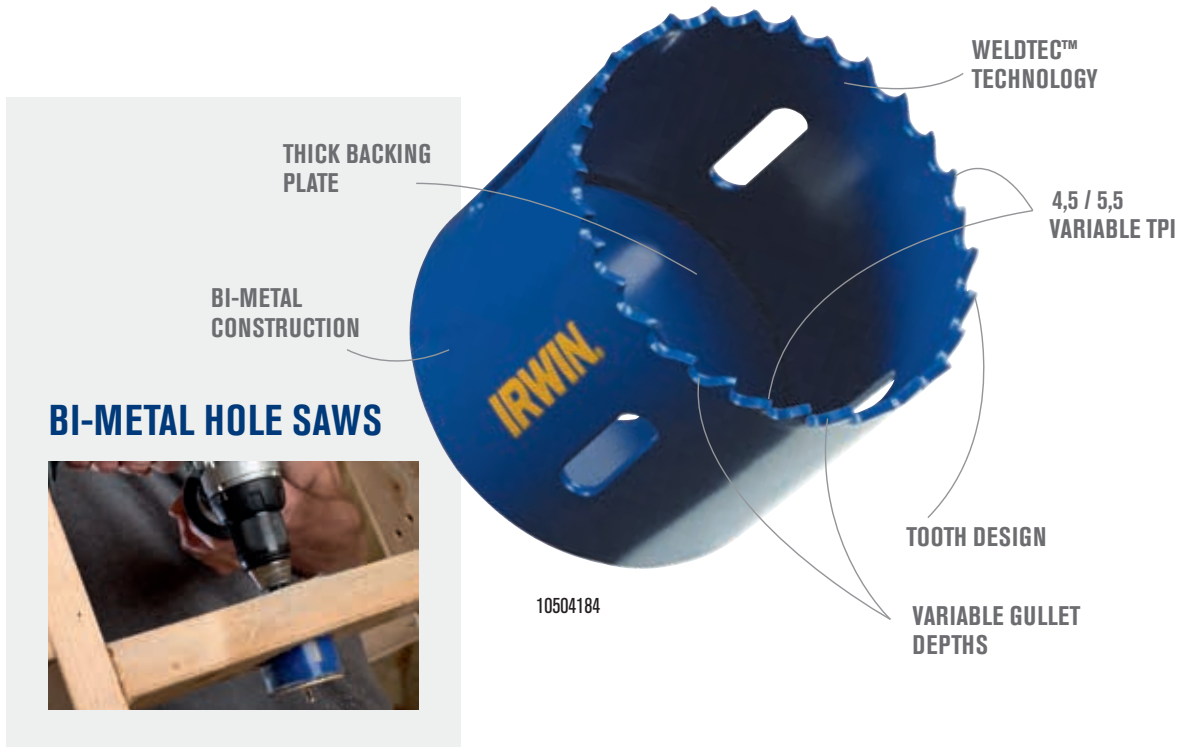

BI-METAL HOLE SAWS



1. **WELDTEC™ TECHNOLOGY**
Delivers enhanced durability and higher cutting speed
2. **TOOTH DESIGN**
For up to 100% longer life and 50% faster cutting*
3. **4,5 / 5,5 VARIABLE TPI**
For faster cuts, less torque build-up and enhanced chip removal
4. **VARIABLE GULLET DEPTHS**
For more efficient chip clearance
5. **THICK BACKING PLATE**
Gives robustness for the toughest jobs
6. **BI-METAL CONSTRUCTION**
For increased life and durability

*vs. previous model

| ITEM NO. | HOLE SAW DIAMETER | EAN | MASTER PACK | SHELF PACK |
|----------|-------------------|---------------|-------------|------------|
| 10504161 | Ø 14mm | 5706915041613 | 160 | 1 |
| 10504162 | Ø 16mm | 5706915041620 | 160 | 1 |
| 10504163 | Ø 17mm | 5706915041637 | 160 | 1 |
| 10504164 | Ø 19mm | 5706915041644 | 160 | 1 |
| 10504165 | Ø 20mm | 5706915041651 | 160 | 1 |
| 10504166 | Ø 21mm | 5706915041668 | 160 | 1 |
| 10504167 | Ø 22mm | 5706915041675 | 160 | 1 |
| 10504168 | Ø 24mm | 5706915041682 | 160 | 1 |
| 10504169 | Ø 25mm | 5706915041699 | 160 | 1 |
| 10504170 | Ø 27mm | 5706915041705 | 160 | 1 |
| 10504171 | Ø 29mm | 5706915041712 | 160 | 1 |
| 10504172 | Ø 30mm | 5706915041729 | 160 | 1 |
| 10504173 | Ø 32mm | 5706915041736 | 120 | 1 |
| 10504174 | Ø 33mm | 5706915041743 | 120 | 1 |
| 10504175 | Ø 35mm | 5706915041750 | 120 | 1 |
| 10504176 | Ø 37mm | 5706915041767 | 120 | 1 |
| 10504177 | Ø 38mm | 5706915041774 | 120 | 1 |
| 10504178 | Ø 40mm | 5706915041781 | 120 | 1 |
| 10504179 | Ø 41mm | 5706915041798 | 120 | 1 |
| 10504180 | Ø 43mm | 5706915041804 | 120 | 1 |
| 10504181 | Ø 44mm | 5706915041811 | 120 | 1 |

BI-METAL HOLE SAWS

BI-METAL HOLE SAWS

| ITEM NO. | HOLE SAW DIAMETER | EAN | MASTER PACK | SHELF PACK |
|----------|-------------------|---------------|-------------|------------|
| 10504182 | Ø 46mm | 5706915041828 | 120 | 1 |
| 10504183 | Ø 48mm | 5706915041835 | 100 | 1 |
| 10504184 | Ø 51mm | 5706915041842 | 100 | 1 |
| 10504185 | Ø 52mm | 5706915041859 | 100 | 1 |
| 10504186 | Ø 54mm | 5706915041866 | 100 | 1 |
| 10507366 | Ø 56mm | 5706915073669 | 100 | 1 |
| 10504187 | Ø 57mm | 5706915041873 | 100 | 1 |
| 10504188 | Ø 59mm | 5706915041880 | 100 | 1 |
| 10504189 | Ø 60mm | 5706915041897 | 100 | 1 |
| 10507367 | Ø 62mm | 5706915073676 | 100 | 1 |
| 10504190 | Ø 64mm | 5706915041903 | 50 | 1 |
| 10504191 | Ø 65mm | 5706915041910 | 50 | 1 |
| 10504192 | Ø 67mm | 5706915041927 | 50 | 1 |
| 10504193 | Ø 68mm | 5706915041934 | 50 | 1 |
| 10504194 | Ø 70mm | 5706915041941 | 50 | 1 |
| 10504195 | Ø 73mm | 5706915041958 | 50 | 1 |
| 10504196 | Ø 76mm | 5706915041965 | 50 | 1 |
| 10504197 | Ø 79mm | 5706915041972 | 50 | 1 |
| 10504198 | Ø 83mm | 5706915041989 | 50 | 1 |
| 10504199 | Ø 86mm | 5706915041996 | 50 | 1 |
| 10504200 | Ø 89mm | 5706915042009 | 50 | 1 |
| 10504201 | Ø 92mm | 5706915042016 | 40 | 1 |
| 10504202 | Ø 95mm | 5706915042023 | 40 | 1 |
| 10504203 | Ø 98mm | 5706915042030 | 40 | 1 |
| 10504204 | Ø 102mm | 5706915042047 | 40 | 1 |
| 10504205 | Ø 105mm | 5706915042054 | 40 | 1 |
| 10504206 | Ø 108mm | 5706915042061 | 40 | 1 |
| 10504207 | Ø 111mm | 5706915042078 | 40 | 1 |
| 10504208 | Ø 114mm | 5706915042085 | 40 | 1 |
| 10504209 | Ø 117mm | 5706915042092 | 20 | 1 |
| 10504210 | Ø 121mm | 5706915042108 | 20 | 1 |
| 10504211 | Ø 127mm | 5706915042115 | 20 | 1 |
| 10505818 | Ø 133mm | 5706915058185 | 20 | 1 |
| 10504212 | Ø 140mm | 5706915042122 | 20 | 1 |
| 10504213 | Ø 152mm | 5706915042139 | 20 | 1 |
| 10505819 | Ø 168mm | 5706915058192 | 20 | 1 |
| 10505820 | Ø 177mm | 5706915058208 | 20 | 1 |
| 10505821 | Ø 210mm | 5706915058215 | 20 | 1 |



10504184

ARBORS / PILOT DRILL BITS FOR BI-METAL HOLE SAW KITS

| ITEM NO. | DESCRIPTION | EAN | MASTER PACK | SHELF PACK |
|----------|-----------------------------------------------------------------|---------------|-------------|------------|
| 10504532 | Pilot Drill | 5706915945324 | 20 | 1 |
| 10504536 | Arbor (Mandrel) 9,5mm chuck diameter, fits Hole Saws 14 - 30mm | 5706915945362 | 20 | 1 |
| 10504533 | Arbor (Mandrel) 13mm chuck diameter, fits Hole Saws 14 - 30mm | 5706915945331 | 20 | 1 |
| 10504534 | Arbor (Mandrel) 9,5mm chuck diameter, fits Hole Saws 32 - 210mm | 5706915945348 | 20 | 1 |
| 10504535 | Arbor (Mandrel) 13mm chuck diameter, fits Hole Saws 32 - 210mm | 5706915945355 | 20 | 1 |
| 10507368 | Extension Rod, 300mm, Chuck size 13+mm | 5706915073683 | 20 | 1 |



10504535

BI-METAL HOLE SAW KITS

IRWIN® Hole Saw Kits are available in a unique attractive soft storage case that incorporates an unbreakable hinge and internal padding that protects the contents. The case has an integrated handle and has a cardboard sleeve that contains important product information.

| ITEM NO. | DESCRIPTION | EAN | MASTER PACK | SHELF PACK |
|----------|---------------------------------------------------------------------------------------------------------------------|---------------|-------------|------------|
| 10507235 | Hole Saw Kit 400SE: 22, 35, 65, 67mm, Arbors 10504535 & 10504536, Pilot drill | 5706915072358 | 144 | 1 |
| 10506439 | Hole Saw Kit 600L: 22, 29, 35, 44, 51, 64mm, Arbors 10504535 & 10504536, Pilot drill | 5706915064391 | 144 | 1 |
| 10506440 | Hole Saw Kit 600L SE: 22, 29, 35, 44, 51, 65mm, Arbors 10504535 & 10504536, Pilot drill | 5706915064407 | 144 | 1 |
| 10506441 | Hole Saw Kit INT600L: 16, 20, 25, 32, 38, 51mm, Arbors 10504535 & 10504536, Pilot drill | 5706915064414 | 144 | 1 |
| 10506442 | Hole Saw Kit 600P: 19, 22, 29, 38, 44, 57mm, Arbors 10504535 & 10504536, Pilot drill | 5706915064421 | 144 | 1 |
| 10506444 | Hole Saw Kit 1200G: 16, 19, 22, 25, 29, 32, 35, 38, 44, 51, 64, 76mm, Arbors 10504533 & 10504535, 3 Pilot drills | 5706915064445 | 96 | 1 |
| 10506445 | Hole Saw Kit 1200G SE: 16, 19, 22, 25, 29, 32, 35, 38, 44, 51, 65, 76mm, Arbors 10504533 & 10504535, 3 Pilot drills | 5706915064452 | 96 | 1 |



10507235

IRWIN®



RECIPROCATING SAW BLADES

BI-METAL RECIPROCATING BLADES

This comprehensive reciprocating saw blade offering has a blade for every application. IRWIN® blades offer superior construction and design making them faster cutting and longer lasting, therefore giving the user a superior cost-per-cut value.

BI-METAL RECIP BLADES

- 1. INCREASED TANG ANGLE**
For up to 50% faster cuts vs. previous model
- 2. BI-METAL CONSTRUCTION**
For a faster cutting, longer lasting blade that can bend without breaking
- 3. WELDTEC™ TECHNOLOGY**
For stronger, longer lasting teeth
- 4. 8% COBALT**
Keeps teeth sharper, longer
- 5. IMPROVED TOOTH CONFIGURATION**
For up to 100% longer life and 50% faster cutting*

LONG-LASTING
BiMetal
TECHNOLOGY

WITH **WELDTEC™**

METAL CUTTING BI-METAL RECIPROCATING SAW BLADES

| ITEM NO. | DESCRIPTION | BLADES PER PACK | EAN | MASTER PACK | SHELF PACK | CUTS ALL METALS including non ferrous, pipe conduit, stainless & sheet metal SUITABLE for use with materials 1.5 to 10mm (1/16" to 3/8") thick, dependent on the TPI of the blade AVAILABLE IN 10, 14, 18 and 24TPI on metal cutting recipcs |
|----------|--------------------------------------|-----------------|---------------|-------------|------------|-------------------------------------------------------------------------------------------------------------------------------------------------------------------------------------------------------------------------------------------------------------------------|
| 10506424 | 614R 6" / 150mm 14TPI, Metal Cutting | 2 | 5706915064247 | 150 | 1 | |
| 10506425 | 624R 6" / 150mm 24TPI, Metal Cutting | 2 | 5706915064254 | 150 | 1 | |
| 10506426 | 818R 8" / 200mm 18TPI, Metal Cutting | 2 | 5706915064261 | 90 | 1 | |
| 10504147 | 414R 4" / 100mm 14TPI, Metal Cutting | 5 | 5706915041477 | 100 | 1 | |
| 10504148 | 418R 4" / 100mm 18TPI, Metal Cutting | 5 | 5706915041484 | 100 | 1 | |
| 10504152 | 614R 6" / 150mm 14TPI, Metal Cutting | 5 | 5706915041521 | 100 | 1 | |
| 10504153 | 618R 6" / 150mm 18TPI, Metal Cutting | 5 | 5706915041538 | 100 | 1 | |
| 10504154 | 624R 6" / 150mm 24TPI, Metal Cutting | 5 | 5706915041545 | 100 | 1 | |
| 10504156 | 818R 8" / 200mm 18TPI, Metal Cutting | 5 | 5706915041569 | 50 | 1 | |
| 10504143 | 614R 6" / 150mm 14TPI, Metal Cutting | 25 | 5706915041439 | 20 | 1 | |
| 10504140 | 818R 8" / 200mm 18TPI, Metal Cutting | 25 | 5706915041408 | 10 | 1 | |



METAL & WOOD CUTTING BI-METAL RECIPROCATING BLADES



| CUTS COMPOSITION MATERIALS such as plastic, wood, pipe, carbon steel & stainless steel SUITABLE for use with materials 3.2mm (1/8") & thicker AVAILABLE IN 10 TPI in 150, 200 & 300mm (6", 8" & 12") sizes | ITEM NO. | DESCRIPTION | BLADES PER PACK | EAN | MASTER PACK | SHELF PACK |
|------------------------------------------------------------------------------------------------------------------------------------------------------------------------------------------------------------------|----------|----------------------------------------------|---------------------------------------------|---------------|---------------|------------|
| | | 10506427 | 610R 6" / 150mm 10TPI, Metal & Wood Cutting | 2 | 5706915064278 | 150 |
| | 10506428 | 810R 8" / 200mm 10TPI, Metal & Wood Cutting | 2 | 5706915064285 | 90 | 1 |
| | 10504151 | 610R 6" / 150mm 10TPI, Metal & Wood Cutting | 5 | 5706915041514 | 100 | 1 |
| | 10504157 | 810R 8" / 200mm 10TPI, Metal & Wood Cutting | 5 | 5706915041576 | 50 | 1 |
| | 10504159 | 110R 12" / 300mm 10TPI, Metal & Wood Cutting | 5 | 5706915041590 | 50 | 1 |
| | 10504141 | 810R 8" / 200mm 10TPI, Metal & Wood Cutting | 25 | 5706915041415 | 10 | 1 |
| | 10504142 | 110R 12" / 300mm 10TPI, Metal & Wood Cutting | 25 | 5706915041422 | 25 | 1 |

NAIL-EMBEDDED BI-METAL RECIPROCATING BLADES



| CUTS NAIL EMBEDDED WOOD SUITABLE for use with materials 5mm (3/16") & thicker AVAILABLE IN 6TPI in 150, 225 & 300mm (6", 9" & 12") sizes | ITEM NO. | DESCRIPTION | BLADES PER PACK | EAN | MASTER PACK | SHELF PACK |
|------------------------------------------------------------------------------------------------------------------------------------------------|----------|---------------------------------------------------|--------------------------------------------------|---------------|---------------|------------|
| | | 10506429 | 656R 6" / 150mm 6TPI, Nail-Embedded Wood Cutting | 2 | 5706915064292 | 150 |
| | 10506430 | 956R 9" / 225mm 6TPI, Nail-Embedded Wood Cutting | 2 | 5706915064308 | 90 | 1 |
| | 10504155 | 656R 6" / 150mm 6TPI, Nail-Embedded Wood Cutting | 5 | 5706915041552 | 100 | 1 |
| | 10504158 | 956R 9" / 225mm 6TPI, Nail-Embedded Wood Cutting | 5 | 5706915041583 | 50 | 1 |
| | 10504160 | 156R 12" / 300mm 6TPI, Nail-Embedded Wood Cutting | 5 | 5706915041606 | 50 | 1 |
| | 10504146 | 656R 6" / 150mm 6TPI, Nail-Embedded Wood Cutting | 25 | 5706915041460 | 20 | 1 |
| | 10504149 | 956R 9" / 225mm 6TPI, Nail-Embedded Wood Cutting | 25 | 5706915041491 | 10 | 1 |
| | 10504144 | 156R 12" / 300mm 6TPI, Nail-Embedded Wood Cutting | 25 | 5706915041446 | 10 | 1 |

DEMOLITION BI-METAL RECIPROCATING BLADES



| HEAVY-DUTY & DEMOLITION applications in wood & metal SUITABLE for use with materials 5mm (3/16") & thicker AVAILABLE IN 6 or 10 TPI in 225mm (9") | ITEM NO. | DESCRIPTION | BLADES PER PACK | EAN | MASTER PACK | SHELF PACK |
|---------------------------------------------------------------------------------------------------------------------------------------------------------|----------|------------------------------------------------|-----------------------------------------------|---------------|---------------|------------|
| | | 10504138 | 966R 9" / 225mm 6TPI, Demolition Applications | 5 | 5706915041385 | 50 |
| | 10504139 | 960R 9" / 225mm 10TPI, Demolition Applications | 5 | 5706915041392 | 50 | 1 |

WOOD CUTTING BI-METAL RECIPROCATING BLADES



| FAST CUTTING in wood SUITABLE for use with materials 5mm (3/16") & thicker AVAILABLE IN 6 TPI in 150mm (6") | ITEM NO. | DESCRIPTION | BLADES PER PACK | EAN | MASTER PACK | SHELF PACK |
|-------------------------------------------------------------------------------------------------------------------|----------|-------------|------------------------------------|-----|---------------|------------|
| | | 10504150 | 606R 6" / 150mm 6TPI, Wood Cutting | 5 | 5706915041507 | 100 |

RECIPROCATING SAW BLADES

MASTER-GRIT RECIPROCATING BLADES



| ITEM NO. | DESCRIPTION | BLADES PER PACK | EAN | MASTER PACK | SHELF PACK |
|----------|-------------------------------|-----------------|---------------|-------------|------------|
| 10507365 | 80ORG 8" / 200mm Carbide Grit | 2 | 5706915073652 | 80 | 1 |

CARBIDE GRIT EDGE MATERIAL for smooth, quick cuts
CUTS ABRASIVE MATERIALS including cast iron, fiberglass, plaster and marble

WOOD, COMPOSITION MATERIAL & PLASTIC CUTTING HCS RECIPROCATING BLADES



| ITEM NO. | DESCRIPTION | BLADES PER PACK | EAN | MASTER PACK | SHELF PACK |
|----------|------------------------------------------------------|-----------------|---------------|-------------|------------|
| 10506431 | S617K, HCS, 6" / 150mm 3TPI, Wood Cutting | 2 | 5706915064315 | 100 | 1 |
| 10506432 | S2345X, HCS, 8" / 200mm PROG 4/2,4 TPI, Wood Cutting | 2 | 5706915064322 | 100 | 1 |
| 10505812 | S617K, HCS, 6" / 150mm, 3TPI, Wood Cutting | 5 | 5706915058123 | 50 | 1 |
| 10505813 | S1131L, HCS, 9" / 225mm, 5TPI, Wood Cutting | 5 | 5706915058130 | 50 | 1 |
| 10505814 | S2345X, HCS, 8" / 200mm PROG 4/2.4TPI, Wood Cutting | 5 | 5706915058147 | 50 | 1 |

FAST CUTTING in wood composition material & plastic
RANGE of regular (10505812 and 10505813) and progressive teeth (10505814)
AVAILABLE in 3 tooth configurations 3TPI / 5TPI & 4/2.4TPI

MASONRY RECIPROCATING BLADES



| ITEM NO. | DESCRIPTION | BLADES PER PACK | EAN | MASTER PACK | SHELF PACK |
|----------|----------------------------------------|-----------------|---------------|-------------|------------|
| 10507846 | MRB 235 x 20mm 2,5TPI, Masonry Cutting | - | 5706915078466 | 25 | 1 |
| 10507847 | MRB 300 x 50mm 2,5TPI, Masonry Cutting | - | 5706915078473 | 25 | 1 |
| 10507848 | MRB 450 x 50mm 2,5TPI, Masonry Cutting | - | 5706915078480 | 25 | 1 |

FAST, DURABLE AND PRECISE CUTTING in many masonry materials like clay bricks, limestone or gas concrete.
UNIVERSAL 1/2" SHANK



JIGSAW BLADES

This comprehensive jigsaw blade offering has a blade for every application. The range includes both T-shank and U-shank to fit all of today's most popular jigsaw machines.

IRWIN® Jigsaw Blades are manufactured from the following high quality materials:

HCS Carbon steel for use in softer materials such as wood, laminated chipboard, and plastics.

HSS Fully hardened high-speed steel for use in metal, aluminium, and non-ferrous metal.

WOOD CUTTING HCS JIGSAW BLADES - T-SHANK



| 3-SIDED, FLEAM GROUND TEETH for fast cut and clean finishes FAST AND SMOOTH CUTS in all wood applications | ITEM NO. | DESCRIPTION | BLADES PER PACK | EAN | MASTER PACK | SHELF PACK |
|--------------------------------------------------------------------------------------------------------------|----------|----------------------------------------------------------------------|--------------------------------------------------|---------------|---------------|------------|
| | | 10504218 | HCS, 100mm, 6 TPI, T144D, Standard, Wood Cutting | 5 | 5706915042184 | 100 |
| | 10504219 | HCS, 100mm, 10 TPI, T101B, Side Ground, Wood Cutting | 5 | 5706915042191 | 100 | 1 |
| | 10504221 | HCS, 100mm, 8 TPI, T111C, Standard, Wood Cutting | 5 | 5706915042214 | 100 | 1 |
| | 10504222 | HCS, 100mm, 6 TPI, T101D, Side Ground, Wood Cutting | 5 | 5706915042221 | 100 | 1 |
| | 10504223 | HCS, 100mm, 10 TPI, T101BR, Side Ground Reverse, Wood Cutting | 5 | 5706915042238 | 100 | 1 |
| | 10504224 | HCS, 100mm, 6 TPI, T244D, Standard Contour, Wood Cutting | 5 | 5706915042245 | 100 | 1 |
| | 10504226 | HCS, 83mm, 20 TPI, T101AQ, Side Ground Narrow Contour, Wood Cutting | 5 | 5706915042269 | 100 | 1 |
| | 10504227 | HCS, 83mm, 12 TPI, T119BQ, Standard Narrow Contour, Wood Cutting | 5 | 5706915042276 | 100 | 1 |
| | 10504228 | HCS, 115mm, Progressive 8-13TPI, T234X, Side Ground, Wood Cutting | 5 | 5706915042283 | 100 | 1 |
| | 10504229 | HCS, 115mm, 8 TPI, T301CD, Side Ground, Wood Cutting | 5 | 5706915042290 | 100 | 1 |
| | 10504410 | HCS, 100mm, 6 TPI, T144DP, Standard Extra Thick 1.68mm, Wood Cutting | 5 | 5706915044102 | 100 | 1 |
| | 10504545 | HCS, 100mm, 6 TPI, T144D, Standard, Wood Cutting | 100 | 5706915945454 | 10 | 1 |

METAL CUTTING HSS JIGSAW BLADES - T-SHANK



| HSS MILLED TEETH for longer life and fast cuts in metal EXTENDED LIFE for fast and even cuts in thin and thick metal | ITEM NO. | DESCRIPTION | BLADES PER PACK | EAN | MASTER PACK | SHELF PACK |
|-------------------------------------------------------------------------------------------------------------------------|----------|--------------------------------------------------------|-----------------|---------------|-------------|------------|
| | 10504220 | HSS, 92mm, Progressive 17-23TPI, T118A, Metal Cutting | 5 | 5706915042207 | 100 | 1 |
| | 10504225 | HSS, 92mm, Progressive 11-13TPI, T118B, Metal Cutting | 5 | 5706915042252 | 100 | 1 |
| | 10504234 | HSS, 92mm, 36 TPI, T118G, Metal Cutting | 5 | 5706915042344 | 100 | 1 |
| | 10504231 | HSS, 100mm, 8 TPI, T127D, Metal Cutting | 5 | 5706915042313 | 100 | 1 |
| | 10504233 | HSS, 100mm, Progressive 10-20TPI, T123X, Metal Cutting | 5 | 5706915042337 | 100 | 1 |
| | 10504230 | HSS, 132mm, 24 TPI, T318A, Metal Cutting | 5 | 5706915042306 | 100 | 1 |

METAL & WOOD CUTTING BI-METAL JIGSAW BLADES - T-SHANK



| PROGRESSIVE TOOTH FORM for all-purpose cutting in wood and metal BI-METAL CONSTRUCTION for extended life in wood and metal | ITEM NO. | DESCRIPTION | BLADES PER PACK | EAN | MASTER PACK | SHELF PACK |
|-------------------------------------------------------------------------------------------------------------------------------|----------|---------------------------------------------------------------|-----------------|---------------|-------------|------------|
| | 10504232 | BIM, 132mm, Progressive 5-10TPI, T345XF, Metal & Wood Cutting | 5 | 5706915042320 | 100 | 1 |

JIGSAW BLADES

FIBER & PLASTER CARBIDE TIPPED JIGSAW BLADES - T-SHANK



| ITEM NO. | DESCRIPTION | BLADES PER PACK | EAN | MASTER PACK | SHELF PACK |
|----------|-------------------------------------------------------------|-----------------|---------------|-------------|------------|
| 10505815 | T141HM Carbide Tipped, 100mm, 6TPI, Fiber & Plastic Cutting | 1 | 5706915058154 | 100 | 1 |
| 10505816 | T341HM Carbide Tipped, 132mm, 6TPI | 1 | 5706915058161 | 100 | 1 |

CARBIDE TIPPED for long lifetime, especially for abrasive materials

METAL & WOOD CUTTING JIGSAW BLADE SETS - T-SHANK

| ITEM NO. | DESCRIPTION | BLADES PER PACK | EAN | MASTER PACK | SHELF PACK |
|----------|---------------------------------------------------------------------------------------------------------------------------------------------------------------------------------------------------------------------------------------------------------------------------------------------------|-----------------|---------------|-------------|------------|
| 10505817 | Jigsaw Set T-Shank: 2 x 10504221 Wood, 100mm, 8 TPI 2 x 10504218 Wood, 100mm, 6 TPI (fast cut) 2 x 10504219 Wood, 100mm, 10 TPI 1 x 10504222 Wood, 100mm, 6 TPI (clean cut) 2 x 10504220 Metal, 92mm, Progressive 17 - 23 TPI 1 x 10504225 Metal, 92mm, Progressive 11 - 13 TPI | 10 | 5706915058178 | 50 | 1 |



WOOD CUTTING HCS JIGSAW BLADES - U-SHANK



| ITEM NO. | DESCRIPTION | BLADES PER PACK | EAN | MASTER PACK | SHELF PACK |
|----------|-------------------------------------------------------------------|-----------------|---------------|-------------|------------|
| 10504235 | HCS, 100mm, 6 TPI, U144D, Standard, Wood Cutting | 5 | 5706915042351 | 100 | 1 |
| 10504288 | HCS, 100mm, 10 TPI, U101B, Side Ground, Wood Cutting | 5 | 5706915042887 | 100 | 1 |
| 10504290 | HCS, 100mm, 8 TPI, U111C, Standard, Wood Cutting | 5 | 5706915042900 | 100 | 1 |
| 10504291 | HCS, 100mm, 6 TPI, U101D, Side Ground, Wood Cutting | 5 | 5706915042917 | 100 | 1 |
| 10504292 | HCS, 100mm, 6 TPI, U244D, Standard Contour, Wood Cutting | 5 | 5706915042924 | 100 | 1 |
| 10504295 | HCS, 115mm, Progressive 8-13TPI, U234X, Side Ground, Wood Cutting | 5 | 5706915042955 | 100 | 1 |

3-SIDED, FLEAM GROUND TEETH for fast cut and clean finishes
FAST AND SMOOTH CUTS in all wood applications

METAL CUTTING HSS JIGSAW BLADES - U-SHANK



| ITEM NO. | DESCRIPTION | BLADES PER PACK | EAN | MASTER PACK | SHELF PACK |
|----------|--------------------------------------------------------|-----------------|---------------|-------------|------------|
| 10504289 | HSS, 70mm, 24 TPI, U118A, Metal Cutting | 5 | 5706915042894 | 100 | 1 |
| 10504293 | HSS, 70mm, 12 TPI, U118B, Metal Cutting | 5 | 5706915042931 | 100 | 1 |
| 10504294 | HSS, 70mm, 36 TPI, U118G, Metal Cutting | 5 | 5706915042948 | 100 | 1 |
| 10504297 | HSS, 100mm, Progressive 10-20TPI, U123X, Metal Cutting | 5 | 5706915042979 | 100 | 1 |

HSS MILLED TEETH for longer life and fast cuts in metal
EXTENDED LIFE for fast and even cuts in thin and thick metal

METAL & WOOD CUTTING BI-METAL JIGSAW BLADES - U-SHANK



| ITEM NO. | DESCRIPTION | BLADES PER PACK | EAN | MASTER PACK | SHELF PACK |
|----------|---------------------------------------------------------------|-----------------|---------------|-------------|------------|
| 10504296 | BIM, 132mm, Progressive 5-10TPI, U345XF, Metal & Wood Cutting | 5 | 5706915042962 | 100 | 1 |



PROGRESSIVE TOOTH FORM for all-purpose cutting in wood and metal
BI-METAL CONSTRUCTION for extended life in wood and metal

| ITEM NO. | PAGE | ITEM NO. | PAGE | ITEM NO. | PAGE | ITEM NO. | PAGE | ITEM NO. | PAGE | ITEM NO. | PAGE | ITEM NO. | PAGE | ITEM NO. | PAGE |
|----------|------|----------|------|-----------|------|---------------|------|---------------|------|------------|------|----------|------|-----------|------|
| T10T | 6 | 10507640 | 14 | T35010E | 22 | TG24510 | 28 | 10505707 | 36 | TM444S6 | 40 | 1988934 | 49 | 10507771 | 59 |
| T13T | 6 | 10507641 | 14 | T240 | 22 | TG24512 | 28 | 10503532 | 36 | 10507932 | 40 | 1988936 | 49 | T41211000 | 59 |
| T11T | 6 | 10505498 | 14 | T23112 | 22 | TG24514 | 28 | 10503533 | 36 | 10503543 | 41 | 1988936 | 49 | T3TON3VS | 59 |
| 10508019 | 6 | 10505500 | 14 | T23212 | 22 | TG2468 | 28 | 10507424 | 36 | 10503544 | 41 | 1988935 | 49 | 4935505 | 59 |
| 10508018 | 6 | 10505502 | 14 | T233C | 22 | TG24610 | 28 | 10503534 | 36 | 10503545 | 41 | 1988934 | 49 | T6TON6VS | 59 |
| 10508017 | 6 | 1910231 | 15 | T234C | 22 | TG24612 | 28 | 10503535 | 36 | TM22006 | 41 | 10503574 | 53 | 8ZR | 59 |
| T03T | 7 | 10505877 | 15 | T235C | 22 | TG56 | 28 | 10505162 | 36 | TM220012 | 41 | 10503575 | 53 | T52ED | 60 |
| T01T | 7 | 10505876 | 15 | T233CDB | 22 | TG056 | 28 | 10505163 | 36 | TMR22089 | 41 | 10503576 | 53 | T5212ED | 60 |
| T0302EL4 | 7 | 10505493 | 15 | T234CDB | 22 | TG67 | 28 | 10505164 | 36 | TMR2210 | 41 | 10503577 | 53 | T53ED | 60 |
| T0102EL4 | 7 | 10505494 | 15 | 10504523 | 24 | TG69 | 28 | 10505165 | 36 | 10503546 | 41 | 10503578 | 53 | T52PD | 60 |
| T09T | 7 | 10505495 | 15 | 10504524 | 24 | TG691 | 28 | TNA2059343000 | 36 | 10503547 | 41 | 10503579 | 53 | T5212PD | 60 |
| T07T | 7 | 10505517 | 15 | 10504525 | 24 | TG950 | 28 | TNA2072330000 | 36 | TM2226 | 41 | 10503569 | 53 | T53PD | 60 |
| T05T | 7 | 10505518 | 15 | 10507929 | 24 | TG69NB | 28 | TXP1211300000 | 36 | TM22261012 | 41 | 10503570 | 53 | TV149B | 60 |
| T1002EL4 | 7 | 10505503 | 16 | 10505897 | 24 | 10504309N | 29 | 10501671 | 38 | TM1838W | 41 | 10503571 | 53 | TV150B | 60 |
| T0902EL4 | 7 | 10505504 | 16 | 10505898 | 24 | 10504310N | 29 | 10501673 | 38 | TM2153 | 41 | 10503572 | 53 | TV175B | 60 |
| T0702EL4 | 7 | 10505505 | 16 | 10505899 | 24 | 10504311N | 29 | 10501674 | 38 | TM2154 | 41 | 10503573 | 53 | TV75B | 61 |
| T0502EL4 | 7 | 10505506 | 16 | 10504520 | 24 | 10504313N | 29 | 10501675 | 38 | TMR2049 | 41 | 10503564 | 53 | T414 | 61 |
| T14T | 7 | 10508153 | 16 | 10504521 | 24 | 10504315N | 30 | 10501676 | 38 | TM2083 | 41 | 10503565 | 53 | T1SB | 61 |
| T15T | 7 | 10508152 | 16 | 10504522 | 24 | 10504316N | 30 | 10501678 | 38 | TM2450 | 41 | 10503566 | 53 | T3SB | 61 |
| T1602EL4 | 7 | 10508151 | 16 | 10504530 | 24 | 10504314N | 30 | 10501679 | 38 | TM2451 | 41 | 10503567 | 53 | T4SB | 61 |
| T1402EL4 | 7 | 10508154 | 16 | 10504531 | 24 | 10503621 | 33 | 10501680 | 38 | T04 | 42 | 10503568 | 53 | T6SB | 61 |
| T1502EL4 | 7 | 10508156 | 16 | 10504407 | 25 | 10503622 | 33 | 10501681 | 38 | TSP4 | 42 | T1365 | 54 | T843423SB | 61 |
| 10507190 | 7 | 10506437 | 16 | 10506437 | 25 | 10503623 | 33 | 10501683 | 38 | T05 | 42 | T1366 | 54 | 10507772 | 61 |
| 10507189 | 7 | 10505483 | 16 | 10504408 | 25 | 10503624 | 33 | 10501684 | 38 | TSP5 | 42 | T1367 | 54 | FG3 | 61 |
| T17EL4 | 7 | 10505486 | 17 | 10504409 | 25 | 10503625 | 33 | 10501685 | 38 | T07 | 42 | T1369 | 54 | FG4 | 61 |
| T19EL4 | 7 | 10505488 | 17 | T914H | 26 | 1909432 | 34 | 10501686 | 38 | T778 | 42 | T13611 | 54 | FG412 | 61 |
| T18R | 7 | 10505490 | 17 | T918H | 26 | 1912454 | 34 | 10501687 | 38 | T06012 | 42 | TL1366 | 54 | FG5 | 61 |
| T24R | 7 | 10505492 | 17 | T924H | 26 | 1912455 | 34 | 10501688 | 38 | T0912 | 42 | T136D | 54 | FG6 | 61 |
| T18DR | 7 | 10508161 | 17 | T930H | 26 | 10503628 | 34 | 10501689 | 38 | TA151 | 42 | T1352 | 54 | T181C | 61 |
| T165EL4 | 8 | 10508160 | 17 | T936H | 26 | 10503626 | 34 | 10501690 | 38 | TA151R | 42 | T1353 | 54 | T182C | 61 |
| T18EL4 | 8 | 10508159 | 17 | T942H | 26 | 10503623 | 34 | 10501691 | 38 | TS12 | 42 | T1354 | 54 | T183C | 61 |
| T9SP | 8 | 10508158 | 17 | TBC914H | 26 | 1912456 | 34 | 10501693 | 38 | TS1238 | 42 | T1355 | 54 | T92C | 61 |
| T20EL4 | 8 | 10505872 | 18 | TBC918H | 26 | 1909433 | 34 | 10504711 | 38 | T0220D | 42 | T1356 | 54 | T9212C | 61 |
| T18SP | 8 | 10505873 | 18 | TBC924H | 26 | 10503630 | 34 | 10504712 | 38 | T778D | 42 | T1357 | 54 | T9312C | 61 |
| T24SP | 8 | 10505874 | 18 | TBC930H | 26 | 10503631 | 34 | 10503733 | 38 | TA151B | 42 | T1359 | 54 | T96 | 61 |
| 8 | 8 | 10505868 | 18 | TBC936H | 26 | 10505538 | 35 | 10501768 | 39 | 10505942 | 45 | TL1354 | 54 | TS10 | 61 |
| 4 | 8 | 10505869 | 18 | TTBC914 | 26 | 10505539 | 35 | 10501698 | 39 | 10505943 | 45 | T135D | 54 | T23C | 62 |
| 2 | 8 | 10505870 | 18 | TTBC918 | 26 | 10505540 | 35 | 10501699 | 39 | 10505944 | 45 | T135E | 54 | T25C | 62 |
| 12L3 | 8 | 10505865 | 19 | TTBC924 | 26 | 10505541 | 35 | 10501700 | 39 | 10505945 | 45 | TM130 | 54 | T112C | 62 |
| 23 | 8 | 10505866 | 19 | TTBC930 | 26 | 10505555 | 35 | 10501701 | 39 | 10505946 | 45 | TM140 | 54 | T114C | 62 |
| 29 | 8 | 10505867 | 19 | TTBC936 | 26 | 10505556 | 35 | 10501703 | 39 | 10505947 | 45 | TM141 | 54 | T36C | 62 |
| 251 | 8 | 10505871 | 19 | TBC924E | 26 | 10505543 | 35 | 10501704 | 39 | T506QCEL7 | 46 | TMFC153 | 54 | 84C | 62 |
| 25ZR | 8 | 10505519 | 19 | TWC6 | 27 | 10505542 | 35 | 10501705 | 39 | TA12QCEL7 | 46 | T1213 | 55 | T23DK | 62 |
| 27ZR | 9 | 10503642 | 21 | TWC16 | 27 | 10503530 | 35 | 10503666 | 39 | T518QCEL7 | 46 | T1214 | 55 | T25DK | 62 |
| 2071910 | 9 | T3008 | 21 | TCC26 | 27 | 10503531 | 35 | 10501707 | 39 | T524QCEL7 | 46 | T1216 | 55 | T112DK | 62 |
| 4092 | 9 | T30010 | 21 | TJ914H | 27 | 10505548 | 35 | 10503667 | 39 | T536QCEL7 | 46 | T1218 | 55 | T114DK | 62 |
| 4935309 | 9 | T30012 | 21 | TJ918H | 27 | 10505549 | 35 | 10501708 | 39 | T546EL7 | 47 | T12110 | 55 | T36DK | 62 |
| 4008 | 9 | T30014 | 21 | TJ924H | 27 | 10505550 | 35 | 10501709 | 39 | T5462EL7 | 47 | T12112 | 55 | T84DK | 62 |
| 4022ZR | 9 | T30018 | 21 | TJ930H | 27 | 10505544 | 35 | 10503668 | 39 | T5412EL7 | 47 | T1224 | 55 | T23L | 62 |
| 4052ZR | 9 | T30024 | 21 | TJ936H | 27 | 10505545 | 35 | 10501710 | 39 | T54122EL7 | 47 | T1192 | 55 | T25L | 62 |
| T77T | 9 | T30036 | 21 | TJ942H | 27 | 10505546 | 35 | 10503669 | 39 | T53006EL7 | 47 | T1193 | 55 | T112L | 62 |
| T214T | 9 | T30018A | 21 | TJ918F | 27 | 10505602 | 35 | 10503423 | 39 | T530062EL7 | 47 | T1194 | 55 | T114L | 62 |
| T76KBT | 9 | T30036A | 21 | TJ924F | 27 | 10505603 | 35 | 10503670 | 39 | T59100ECD | 47 | T1196 | 55 | T36L | 62 |
| 10508020 | 9 | T30018C | 21 | TJ930F | 27 | 10505547 | 35 | 10503425 | 39 | T59200ECD | 47 | T1203 | 55 | T84L | 62 |
| T71 | 9 | T30036C | 21 | TJ924E | 27 | TXP1624533000 | 35 | 10503835 | 39 | T59400ECD | 47 | T1204 | 55 | T230 | 62 |
| 4052ZR | 9 | T30024F | 21 | T914UEFGT | 27 | TXP1124610000 | 35 | 10503836 | 39 | T58100EL7 | 47 | T1206 | 55 | T250 | 62 |
| 10507626 | 13 | T30036F | 21 | T918UEFGT | 27 | TXP1124762000 | 35 | 10503429 | 39 | T58200EL7 | 47 | T1208 | 55 | T1120 | 62 |
| 10507627 | 13 | T3508 | 22 | T924UEFGT | 27 | TXP3011300000 | 35 | 10503876 | 39 | T58300EL7 | 47 | T12010 | 55 | T1140 | 62 |
| 10507628 | 13 | T35010 | 22 | T930UEFGT | 27 | TXP3020533000 | 35 | 10503431 | 39 | 1826576 | 47 | T12012 | 55 | T360 | 62 |
| 4935097 | 13 | T35012 | 22 | T936UEFGT | 27 | TXP3020610000 | 35 | 10503541 | 39 | 1826577 | 47 | T8434 | 57 | T840 | 62 |
| 10507629 | 13 | T35014 | 22 | T942UEFGT | 27 | TXP3020762000 | 35 | TM44418 | 40 | 1826578 | 47 | T36 | 57 | T1C | 62 |
| 10507630 | 13 | T35018 | 22 | T914KIT | 27 | TXP3024533000 | 35 | TM44414 | 40 | 1826579 | 47 | 112 | 57 | T3C | 62 |
| 10507631 | 13 | T35024 | 22 | T918KIT | 27 | TXP3024610000 | 35 | TM44438 | 40 | 1988919 | 48 | 114ZR | 57 | T4C | 62 |
| 10507632 | 13 | T35036 | 22 | T924KIT | 27 | TXP3024762000 | 35 | TM44412 | 40 | 1988931 | 48 | 23ZR | 57 | T5C | 62 |
| 10507633 | 13 | T35048 | 22 | T930KIT | 27 | TXP1124762000 | 35 | TM44458 | 40 | 1988920 | 48 | T25 | 57 | T6C | 62 |
| 2078116 | 13 | T35018A | 22 | T936KIT | 27 | TXP3011300000 | 35 | TM44434 | 40 | 1988932 | 48 | 1978271 | 58 | T8C | 62 |
| 2078120 | 13 | T35024A | 22 | T942KIT | 27 | TXP3020533000 | 35 | TM44441 | 40 | 1988933 | 48 | 1978272 | 58 | T1D | 62 |
| 10507634 | 14 | T35036A | 22 | TBC914KIT | 27 | TXP3024533000 | 35 | TM444114 | 40 | 1988919 | 48 | 1ZR | 59 | T3D | 62 |
| 10507635 | 14 | T35048A | 22 | TBC918KIT | 27 | 10507858 | 36 | TM444112 | 40 | 1988920 | 48 | 3 | 59 | T4D | 62 |
| 10507636 | 14 | T35010C | 22 | TBC924KIT | 27 | 10507860 | 36 | TM4442 | 40 | 1988931 | 48 | 4ZR | 59 | T5D | 62 |
| 10507637 | 14 | T35018C | 22 | TBC930KIT | 27 | 1965487 | 36 | TM44433 | 40 | 1988932 | 48 | 5 | 59 | T6D | 62 |
| 10507638 | 14 | T35024C | 22 | TBC936KIT | 27 | 10505705 | 36 | TM44434 | 40 | 1988933 | 48 | 6 | 59 | T8D | 62 |
| 10507639 | 14 | T35048C | 22 | TG2458 | 28 | T106150 | 36 | TM44435 | 40 | 1988935 | 49 | 8ZR | 59 | T661053 | 62 |

CATALOGUE INDEX

| ITEM NO. | PAGE | ITEM NO. | PAGE | ITEM NO. | PAGE | ITEM NO. | PAGE | ITEM NO. | PAGE | ITEM NO. | PAGE | ITEM NO. | PAGE | ITEM NO. | PAGE |
|-----------|------|----------|------|----------|------|----------|------|----------|------|----------|------|----------|------|----------|------|
| T52EDA | 63 | 1951859 | 66 | 10508135 | 77 | T591057 | 89 | 10507164 | 96 | 10502014 | 99 | 10502099 | 102 | 10501927 | 105 |
| T5212EDA | 63 | 1951860 | 66 | 10508136 | 77 | T660032 | 89 | 10507166 | 96 | 10502015 | 99 | 10502100 | 102 | 10501928 | 105 |
| T53EDA | 63 | 1951861 | 66 | 10507843 | 77 | T676810 | 89 | 10507167 | 96 | 10502016 | 99 | 10502101 | 102 | 10501929 | 105 |
| T52EDC | 63 | 1951867 | 67 | 10506543 | 77 | T202 | 90 | 10501941 | 98 | 10502017 | 99 | 10502102 | 102 | 10501930 | 105 |
| T5212EDC | 63 | 1951866 | 67 | 10506546 | 77 | T2020F | 90 | 10507574 | 98 | 10502018 | 99 | 10502103 | 102 | 10501931 | 105 |
| T53EDC | 63 | 1951865 | 67 | 10506544 | 77 | T202EF | 90 | 10501942 | 98 | 10502019 | 99 | 10502104 | 102 | 10501932 | 105 |
| T52EDD | 63 | 1951862 | 67 | 10506547 | 77 | T20030C | 90 | 10507575 | 98 | 10502020 | 99 | 10502105 | 102 | 10501933 | 105 |
| T5212EDD | 63 | 1951863 | 67 | 10507446 | 77 | T20045 | 90 | 10501943 | 98 | 10502021 | 99 | 10502106 | 102 | 10501934 | 105 |
| T52EDJN | 63 | 1951864 | 67 | 10507790 | 79 | T20030CD | 90 | 10501944 | 98 | 10502022 | 99 | 10502107 | 102 | 10501935 | 105 |
| T5212EDJN | 63 | 1951868 | 67 | 10507791 | 79 | T20045D | 90 | 10503844 | 98 | 10502023 | 99 | 10502108 | 102 | 10501936 | 105 |
| T52EDL | 63 | 1951869 | 67 | 10507792 | 79 | T850026 | 90 | 10501945 | 98 | 10502024 | 99 | 10502109 | 102 | 10501937 | 105 |
| T52EDO | 63 | 1951870 | 67 | 10508059 | 79 | 10507485 | 90 | 10501946 | 98 | 10502025 | 99 | 10502110 | 102 | 10501812 | 106 |
| T5212EDO | 63 | 1951881 | 67 | 10508060 | 79 | T210 | 90 | 10501947 | 98 | 10502027 | 99 | 10502111 | 102 | 10501813 | 106 |
| T52EDT | 63 | 1951882 | 68 | 10507793 | 79 | T090700 | 91 | 10501948 | 98 | 10502028 | 99 | 10502112 | 102 | 10501814 | 106 |
| T52PDC | 63 | 1951883 | 68 | 10507794 | 79 | T090700B | 91 | 10501949 | 98 | 10502029 | 99 | 10502113 | 102 | 10501815 | 106 |
| T5212PDC | 63 | 1951884 | 68 | 10507795 | 79 | T113100D | 91 | 10501950 | 98 | 10502030 | 99 | 10502115 | 102 | 10501816 | 106 |
| T53PDC | 63 | 1951885 | 68 | 10508062 | 79 | T090751 | 91 | 10501951 | 98 | 10502031 | 99 | 10502116 | 102 | 10501817 | 106 |
| T5212PDO | 63 | 1953963 | 68 | 10507784 | 80 | T620103 | 91 | 10501952 | 98 | 10502033 | 99 | 10502117 | 102 | 10501818 | 106 |
| T92CC | 63 | T10771 | 69 | 10507785 | 80 | T120422 | 91 | 10501953 | 98 | 10502035 | 99 | 10502118 | 102 | 10501819 | 106 |
| T9212CC | 63 | T10755 | 69 | 10507786 | 80 | T113112 | 91 | 10501954 | 98 | 10502036 | 99 | 10502119 | 102 | 10501820 | 106 |
| T92CD | 63 | T10756 | 69 | 10508052 | 80 | T102010 | 91 | 10501955 | 98 | 10502038 | 99 | 10502120 | 102 | 10501821 | 106 |
| T9212CD | 63 | T10757 | 69 | 10508053 | 80 | T120465 | 91 | 10501956 | 98 | 10502040 | 99 | 10502121 | 102 | 10501822 | 106 |
| T92CE | 63 | T10758 | 69 | 10508054 | 80 | T090757 | 91 | 10501957 | 98 | 10502041 | 99 | 10502122 | 102 | 10501823 | 106 |
| T9312CE | 63 | T10765 | 69 | 10507787 | 80 | T529827 | 91 | 10501958 | 98 | 10502042 | 99 | 10502123 | 102 | 10501824 | 106 |
| T92CF | 63 | T10767 | 69 | 10507788 | 80 | T702025 | 91 | 10501959 | 98 | 10502043 | 99 | 10502124 | 102 | 10501826 | 106 |
| T9312CF | 63 | T10769 | 69 | 10507789 | 80 | T660084 | 91 | 10501960 | 98 | 10502044 | 99 | 10502125 | 102 | 10501827 | 106 |
| T96F | 63 | T10768 | 69 | 10507681 | 81 | T620100A | 91 | 10501961 | 98 | 10502046 | 99 | 10502126 | 102 | 10501830 | 106 |
| T92CG | 63 | T10745 | 69 | 10507684 | 81 | T620100J | 91 | 10501962 | 98 | 10502047 | 99 | 10502127 | 102 | 10501831 | 106 |
| T9312CG | 63 | T10747 | 69 | 10507676 | 82 | T630500A | 91 | 10501963 | 98 | 10502048 | 99 | 10502128 | 102 | 10501834 | 106 |
| T96G | 63 | 10504240 | 71 | 10507677 | 82 | T620103 | 91 | 10501964 | 98 | 10502049 | 99 | 10502129 | 102 | 10501835 | 106 |
| T183CA | 63 | 10504241 | 71 | 10507682 | 82 | T120422 | 91 | 10501965 | 98 | 10502050 | 99 | 10502130 | 102 | 10501836 | 106 |
| T182CB | 63 | 10504243 | 71 | 10507678 | 82 | T630519 | 91 | 10501966 | 98 | 10502052 | 99 | 10502194 | 103 | 10501837 | 106 |
| T183CB | 63 | 10505823 | 71 | 10507679 | 82 | T090757 | 91 | 10501967 | 98 | 10502053 | 99 | 10502195 | 103 | 10501838 | 106 |
| T182CC | 63 | 10505824 | 71 | 10507680 | 82 | T529827 | 91 | 10501968 | 98 | 10502054 | 99 | 10502196 | 103 | 10501841 | 106 |
| T183CC | 63 | 10507102 | 71 | 10507683 | 82 | T201030 | 91 | 10501969 | 98 | 10502056 | 99 | 10502197 | 103 | 10501846 | 106 |
| T183CD | 63 | 10507103 | 71 | 648012R | 83 | TUL223 | 91 | 10501970 | 98 | 10502057 | 99 | 10502198 | 103 | 10501847 | 106 |
| 1951676 | 65 | 10507104 | 71 | 64802 | 83 | T620103 | 91 | 10501971 | 98 | 10502059 | 99 | 10502200 | 103 | 10501848 | 106 |
| 1951677 | 65 | 10507105 | 71 | 64901 | 83 | T220D | 91 | 10501972 | 98 | 10502060 | 99 | 10503643 | 103 | 10501849 | 106 |
| 1951678 | 65 | 10508107 | 72 | 64902 | 83 | 10507124 | 96 | 10501973 | 98 | 10502061 | 99 | 10502184 | 103 | 10501850 | 106 |
| 1951679 | 65 | 10508108 | 72 | 65201 | 83 | 10507125 | 96 | 10501974 | 98 | 10502069 | 99 | 10502185 | 103 | 10501853 | 106 |
| 1951680 | 65 | 10508110 | 72 | 1932892 | 83 | 10507126 | 96 | 10501975 | 98 | 10502070 | 99 | 10502186 | 103 | 10501854 | 106 |
| 1951801 | 65 | 10504245 | 72 | 1932893 | 83 | 10507127 | 96 | 10501976 | 98 | 10503603 | 100 | 10502187 | 103 | 10501855 | 106 |
| 1951802 | 65 | 10504246 | 72 | 1932894 | 83 | 10507128 | 96 | 10501978 | 98 | 10503605 | 100 | 10502188 | 103 | 10501856 | 106 |
| 1951803 | 65 | 10504247 | 72 | 664012R | 83 | 10507129 | 96 | 10501979 | 98 | 10503606 | 100 | 10502189 | 103 | 10501859 | 106 |
| 1951814 | 65 | 10504249 | 72 | 66404 | 83 | 10507131 | 96 | 10501980 | 98 | 10503607 | 100 | 10502190 | 103 | 10501862 | 106 |
| 1951807 | 65 | 10504250 | 72 | 66406 | 83 | 10507132 | 96 | 10501981 | 98 | 10503609 | 100 | 10502191 | 103 | 10501863 | 106 |
| 1951808 | 65 | 10504251 | 72 | 666012 | 83 | 10507133 | 96 | 10501982 | 98 | 10503610 | 100 | 10502192 | 103 | 10501864 | 106 |
| 1951810 | 65 | 10504558 | 72 | 666042 | 83 | 10507134 | 96 | 10501984 | 98 | 10503611 | 100 | 10503644 | 103 | 10501866 | 106 |
| 1951811 | 65 | 10504559 | 72 | 666062 | 83 | 10507135 | 96 | 10501985 | 98 | 10503612 | 100 | 10507198 | 104 | 10501867 | 106 |
| 1951812 | 65 | 10504561 | 72 | 233250 | 83 | 10507136 | 96 | 10501986 | 98 | 10503613 | 100 | 10507199 | 104 | 10501869 | 106 |
| 1951813 | 65 | 10504562 | 72 | 66300 | 83 | 10507137 | 96 | 10501987 | 98 | 10502071 | 100 | 10507200 | 104 | 10501873 | 106 |
| 1951816 | 65 | 10504563 | 72 | 66305SL | 83 | 10507138 | 96 | 10501988 | 98 | 10502072 | 100 | 10507211 | 104 | 10501874 | 106 |
| 1951818 | 66 | 10504567 | 72 | 10505369 | 85 | 10507139 | 96 | 10501989 | 98 | 10502073 | 100 | 10507212 | 104 | 10501877 | 106 |
| 1951819 | 66 | 10506456 | 72 | 10506529 | 85 | 10507140 | 96 | 10501991 | 98 | 10502074 | 100 | 10507213 | 104 | 10501878 | 106 |
| 1951820 | 66 | 1888437 | 73 | 10506531 | 85 | 10507142 | 96 | 10501992 | 98 | 10502075 | 100 | 10507214 | 104 | 10501880 | 106 |
| 1951821 | 66 | 1888438 | 73 | 10506532 | 85 | 10507143 | 96 | 10501993 | 98 | 10502076 | 100 | 10507215 | 104 | 10501882 | 106 |
| 1951824 | 66 | 1888439 | 73 | 10503820 | 85 | 10507144 | 96 | 10501994 | 98 | 10502077 | 100 | 10507216 | 104 | 10501884 | 106 |
| 1951825 | 66 | 10507695 | 73 | 10503818 | 85 | 10507145 | 96 | 10501995 | 98 | 10502080 | 100 | 10507217 | 104 | 10501885 | 106 |
| 1951826 | 66 | 10508104 | 74 | 10503819 | 86 | 10507146 | 96 | 10501996 | 98 | 10503845 | 100 | 10507218 | 104 | 10501886 | 106 |
| 1951827 | 66 | 10507404 | 74 | 10506534 | 86 | 10507147 | 96 | 10501997 | 98 | 10502082 | 100 | 10507219 | 104 | 10501888 | 106 |
| 1951828 | 66 | 10504236 | 74 | 10506535 | 86 | 10507148 | 96 | 10501998 | 98 | 10502083 | 100 | 10507220 | 104 | 10501894 | 107 |
| 1951842 | 66 | 10508105 | 74 | 10503817 | 86 | 10507149 | 96 | 10501999 | 98 | 10502084 | 100 | 10507221 | 104 | 10501895 | 107 |
| 1951843 | 66 | 10504238 | 75 | 10503830 | 87 | 10507150 | 96 | 10502000 | 98 | 10502085 | 100 | 10507222 | 104 | 10501896 | 107 |
| 1951844 | 66 | 10504238 | 75 | 10503831 | 87 | 10507151 | 96 | 10502002 | 98 | 10502086 | 100 | 10507224 | 104 | 10501897 | 107 |
| 1951845 | 66 | 10504237 | 75 | 10503832 | 87 | 10507152 | 96 | 10502004 | 98 | 10502087 | 100 | 10507225 | 104 | 10501898 | 107 |
| 1951846 | 66 | 10508103 | 75 | 10503822 | 87 | 10507153 | 96 | 10502005 | 98 | 10502088 | 100 | 10501919 | 105 | 10501899 | 107 |
| 1951848 | 66 | 10504239 | 75 | 10503823 | 87 | 10507154 | 96 | 10502006 | 98 | 10502092 | 101 | 10501920 | 105 | 10501901 | 107 |
| 1951849 | 66 | 10507449 | 75 | 10503824 | 87 | 10507156 | 96 | 10502007 | 98 | 10502093 | 101 | 10501921 | 105 | 10501902 | 107 |
| 1951850 | 66 | 10505822 | 75 | 10503825 | 87 | 10507157 | 96 | 10502008 | 99 | 10502094 | 101 | 10501922 | 105 | 10501903 | 107 |
| 1951855 | 66 | 10507106 | 76 | 10503826 | 87 | 10507159 | 96 | 10502010 | 99 | 10502095 | 101 | 10501923 | 105 | 10501905 | 107 |
| 1951856 | 66 | 10504553 | 76 | 10503827 | 87 | 10507160 | 96 | 10502011 | 99 | 10502096 | 101 | 10501924 | 105 | 10501906 | 107 |
| 1951857 | 66 | 10504555 | 76 | 10503828 | 87 | 10507161 | 96 | 10502012 | 99 | 10502097 | 101 | 10501925 | 105 | 10501907 | 107 |
| 1951858 | 66 | 10507580 | 76 | 10503829 | 87 | 10507163 | 96 | 10502013 | 99 | 10502098 | 101 | 10501926 | 105 | 10501908 | 107 |

| ITEM NO. | PAGE | ITEM NO. | PAGE | ITEM NO. | PAGE | ITEM NO. | PAGE | ITEM NO. | PAGE | ITEM NO. | PAGE | ITEM NO. | PAGE | ITEM NO. | PAGE |
|----------|------|----------|------|----------|------|----------|------|----------|------|----------|------|----------|------|----------|------|
| 10501910 | 107 | 10502547 | 114 | 10502592 | 116 | 10502252 | 119 | 10502326 | 120 | 10502498 | 121 | 10502626 | 124 | 10502810 | 129 |
| 10501911 | 107 | 10502548 | 114 | 10502593 | 116 | 10502253 | 119 | 10502327 | 120 | 10503858 | 121 | 10502627 | 124 | 10502811 | 129 |
| 10501912 | 107 | 10502549 | 114 | 10502594 | 116 | 10502254 | 119 | 10502328 | 120 | 1868262 | 121 | 10502631 | 124 | 10502812 | 129 |
| 10501913 | 107 | 10502550 | 114 | 10502595 | 116 | 10502255 | 119 | 10502329 | 120 | 1868263 | 121 | 10502633 | 124 | 10502813 | 129 |
| 10501914 | 107 | 10502551 | 114 | 10502596 | 116 | 10502256 | 119 | 10502330 | 120 | 1868264 | 121 | 10502634 | 124 | 10502814 | 129 |
| 10501915 | 107 | 10502552 | 114 | 10502597 | 116 | 10502257 | 119 | 10502331 | 120 | 10502479 | 121 | 10502636 | 124 | 10502815 | 129 |
| 10501916 | 107 | 10502553 | 114 | 10502598 | 116 | 10502258 | 119 | 10502332 | 120 | 1868265 | 121 | 10502641 | 124 | 10502816 | 129 |
| 10507903 | 108 | 10502554 | 114 | 10502599 | 116 | 10502259 | 119 | 10502333 | 120 | 1868266 | 121 | 10502642 | 124 | 10502817 | 129 |
| 10507904 | 108 | 10502555 | 114 | 10502600 | 116 | 10502260 | 119 | 10502334 | 120 | 10502480 | 121 | 10502643 | 124 | 10502818 | 129 |
| 10507905 | 108 | 10502556 | 114 | 10502601 | 116 | 10502261 | 119 | 10502335 | 120 | 1868267 | 121 | 10502644 | 124 | 10502819 | 129 |
| 10507906 | 108 | 10502557 | 114 | 10502602 | 116 | 10502262 | 119 | 10502336 | 120 | 10502481 | 121 | 10502646 | 124 | 10502820 | 129 |
| 10507907 | 108 | 10502558 | 114 | 10502376 | 118 | 10502263 | 119 | 10502337 | 120 | 10502434 | 122 | 10502649 | 124 | 10502821 | 129 |
| 10507909 | 108 | 10502559 | 114 | 10502377 | 118 | 10502264 | 119 | 10502338 | 120 | 10502418 | 122 | 10502651 | 124 | 10502822 | 129 |
| 10507892 | 108 | 10502560 | 114 | 10502378 | 118 | 10502265 | 119 | 10502339 | 120 | 10502419 | 122 | 10502656 | 124 | 10502823 | 129 |
| 10507893 | 108 | 10502561 | 114 | 10502379 | 118 | 10502266 | 119 | 10502340 | 120 | 10502420 | 122 | 10502658 | 124 | 10502830 | 130 |
| 10507894 | 108 | 10502562 | 114 | 10502380 | 118 | 10502267 | 119 | 10502341 | 120 | 10502422 | 122 | 10502659 | 124 | 10502831 | 130 |
| 10507895 | 108 | 10502563 | 114 | 10502381 | 118 | 10502268 | 119 | 10502342 | 120 | 10502424 | 122 | 10502661 | 124 | 10502832 | 130 |
| 10507896 | 108 | 10502564 | 114 | 10502382 | 118 | 10502269 | 119 | 10502343 | 120 | 10502425 | 122 | 10502662 | 124 | 10502833 | 130 |
| 10507897 | 108 | 10502565 | 114 | 10502383 | 118 | 10502270 | 119 | 10502344 | 120 | 10502426 | 122 | 10502666 | 124 | 10502834 | 130 |
| 10507898 | 108 | 10502566 | 114 | 10502384 | 118 | 10502271 | 119 | 10502345 | 120 | 10502427 | 122 | 10502671 | 124 | 10502835 | 130 |
| 10507229 | 109 | 10502567 | 114 | 1863343 | 118 | 10502272 | 119 | 10502346 | 120 | 10502428 | 122 | 10502676 | 124 | 10502836 | 130 |
| 10507230 | 109 | 10502568 | 114 | 10502385 | 118 | 10502273 | 119 | 10502348 | 120 | 10502429 | 122 | 10502680 | 124 | 10502837 | 130 |
| 10507231 | 109 | 10502511 | 115 | 10502386 | 118 | 10502274 | 119 | 10502349 | 120 | 10502430 | 122 | 10502685 | 124 | 10502838 | 130 |
| 10507232 | 109 | 10502512 | 115 | 1863344 | 118 | 10502275 | 119 | 10502350 | 120 | 10502431 | 122 | 10502689 | 124 | 10502839 | 130 |
| 10507233 | 109 | 10502513 | 115 | 10502387 | 118 | 10502276 | 119 | 10502351 | 120 | 10502432 | 122 | 10502690 | 124 | 10502840 | 130 |
| 10507234 | 109 | 10502514 | 115 | 1863345 | 118 | 10502277 | 119 | 10502352 | 120 | 10502433 | 122 | 10502691 | 124 | 10502842 | 130 |
| 10502890 | 109 | 10502515 | 115 | 1863346 | 118 | 10502278 | 119 | 10502353 | 120 | 10502434 | 122 | 10502692 | 124 | 10502843 | 130 |
| 10507267 | 109 | 10502516 | 115 | 10502388 | 118 | 10502279 | 119 | 10502355 | 120 | 10502435 | 122 | 10502693 | 124 | 10502844 | 130 |
| 10507268 | 109 | 10502517 | 115 | 10502389 | 118 | 10502280 | 119 | 10502356 | 120 | 10502436 | 122 | 10502694 | 124 | 10502845 | 130 |
| 10507590 | 109 | 10502518 | 115 | 10502390 | 118 | 10502281 | 119 | 10502357 | 120 | 10502437 | 122 | 10502695 | 124 | 10502846 | 130 |
| 10502865 | 109 | 10502519 | 115 | 10502391 | 118 | 10502282 | 119 | 10502358 | 120 | 10502438 | 122 | 10502696 | 124 | 10502792 | 130 |
| 10503476 | 109 | 10502520 | 115 | 10502392 | 118 | 10502283 | 119 | 10502360 | 120 | 10502439 | 122 | 10502697 | 124 | 10502793 | 130 |
| 10507937 | 109 | 10502521 | 115 | 10502393 | 118 | 10502284 | 119 | 10502361 | 120 | 10502440 | 122 | 10502699 | 124 | 10502794 | 130 |
| 10502202 | 113 | 10502522 | 115 | 10502394 | 118 | 10502285 | 119 | 10502362 | 120 | 10502441 | 122 | 10502701 | 124 | 10502795 | 130 |
| 10502203 | 113 | 10502523 | 115 | 10502395 | 118 | 10502286 | 119 | 10502363 | 120 | 10502442 | 122 | 10507712 | 127 | 10502796 | 130 |
| 10502204 | 113 | 10502524 | 115 | 10502396 | 118 | 10502287 | 119 | 10502364 | 120 | 10502443 | 122 | 10507713 | 127 | 10502797 | 130 |
| 10502205 | 113 | 10502525 | 115 | 10502397 | 118 | 10502288 | 119 | 10502365 | 120 | 10502444 | 122 | 10507714 | 127 | 10502798 | 130 |
| 10502206 | 113 | 10502526 | 115 | 10502398 | 118 | 10502289 | 119 | 10502366 | 120 | 10502445 | 122 | 10507715 | 127 | 10502799 | 130 |
| 10502207 | 113 | 10502527 | 115 | 10502399 | 118 | 10502290 | 119 | 10502367 | 121 | 10502446 | 122 | 10507716 | 127 | 10502800 | 130 |
| 10502208 | 113 | 10502528 | 115 | 10502400 | 118 | 10502291 | 119 | 10502368 | 121 | 10502447 | 122 | 10507717 | 127 | 10508166 | 131 |
| 10502209 | 113 | 10502529 | 115 | 10502401 | 118 | 10502292 | 119 | 10502369 | 121 | 10502448 | 122 | 10507718 | 127 | 10508167 | 131 |
| 10502210 | 113 | 10502530 | 115 | 10502402 | 118 | 10502293 | 119 | 10502370 | 121 | 10502450 | 122 | 10507719 | 127 | 10508168 | 131 |
| 10502211 | 113 | 10502531 | 115 | 10502403 | 118 | 10502294 | 119 | 10502371 | 121 | 10502451 | 122 | 1921930 | 128 | 10508170 | 131 |
| 10502212 | 113 | 10502532 | 115 | 10502404 | 118 | 10502295 | 119 | 10502372 | 121 | 10502452 | 122 | 1921991 | 128 | 10508171 | 131 |
| 10502213 | 113 | 10502533 | 115 | 10502405 | 118 | 10502296 | 119 | 10502373 | 121 | 10502453 | 122 | 1921992 | 128 | 10502738 | 132 |
| 10502214 | 113 | 10502534 | 115 | 10502406 | 118 | 10502297 | 119 | 10502374 | 121 | 10502454 | 122 | 1921993 | 128 | 10502739 | 132 |
| 10502215 | 113 | 10502535 | 115 | 10502407 | 118 | 10502298 | 120 | 10502375 | 121 | 10502456 | 122 | 1921994 | 128 | 10502740 | 132 |
| 10502216 | 113 | 10502536 | 115 | 10502408 | 118 | 10502300 | 120 | 1863347 | 121 | 10502458 | 122 | 1921995 | 128 | 10502741 | 132 |
| 10502217 | 113 | 10502537 | 115 | 10502409 | 118 | 10502301 | 120 | 1863348 | 121 | 10502460 | 122 | 1921996 | 128 | 10502742 | 132 |
| 10502218 | 113 | 10502538 | 115 | 10502410 | 118 | 10502302 | 120 | 1863349 | 121 | 10502461 | 122 | 1921997 | 128 | 10502744 | 132 |
| 10502219 | 113 | 10502539 | 115 | 10502411 | 118 | 10502303 | 120 | 1863350 | 121 | 10502462 | 122 | 10507602 | 128 | 10502745 | 132 |
| 10502220 | 113 | 10502540 | 115 | 10502412 | 118 | 10502304 | 120 | 1863361 | 121 | 10502464 | 122 | 10506620 | 128 | 10502747 | 132 |
| 10502221 | 113 | 10502541 | 115 | 10502413 | 118 | 10502305 | 120 | 1863362 | 121 | 10502466 | 122 | 10506621 | 128 | 10502748 | 132 |
| 10502222 | 113 | 10502572 | 116 | 10502414 | 118 | 10502306 | 120 | 10502482 | 121 | 10502468 | 122 | 10506622 | 128 | 10502749 | 132 |
| 10502223 | 113 | 10502573 | 116 | 10502415 | 118 | 10502307 | 120 | 10502483 | 121 | 10502470 | 122 | 10506623 | 128 | 10502751 | 132 |
| 10502224 | 113 | 10502574 | 116 | 10502416 | 118 | 10502308 | 120 | 10502484 | 121 | 10502474 | 122 | 10506624 | 128 | 10502752 | 132 |
| 10502225 | 113 | 10502575 | 116 | 10502417 | 118 | 10502309 | 120 | 10503855 | 121 | 10502478 | 122 | 10506625 | 128 | 10502754 | 132 |
| 10502226 | 113 | 10502576 | 116 | 10502236 | 119 | 10502310 | 120 | 10502485 | 121 | 10502850 | 123 | 10506626 | 128 | 10502755 | 132 |
| 10502227 | 113 | 10502577 | 116 | 10502237 | 119 | 10502311 | 120 | 10502486 | 121 | 10502851 | 123 | 1921998 | 128 | 10502756 | 132 |
| 10502228 | 113 | 10502578 | 116 | 10502238 | 119 | 10502312 | 120 | 10503856 | 121 | 10502852 | 123 | 1921999 | 128 | 10502757 | 132 |
| 10502229 | 113 | 10502579 | 116 | 10502239 | 119 | 10502313 | 120 | 10502487 | 121 | 10502853 | 123 | 1922000 | 128 | 10502758 | 132 |
| 10502230 | 113 | 10502580 | 116 | 10502240 | 119 | 10502314 | 120 | 10504418 | 121 | 10502854 | 123 | 1922001 | 128 | 10502760 | 132 |
| 10502231 | 113 | 10502581 | 116 | 10502241 | 119 | 10502315 | 120 | 10502488 | 121 | 10502855 | 123 | 1922002 | 128 | 10502761 | 132 |
| 10502232 | 113 | 10502582 | 116 | 10502242 | 119 | 10502316 | 120 | 10504420 | 121 | 10502856 | 123 | 1922003 | 128 | 10502762 | 132 |
| 10502507 | 114 | 10502583 | 116 | 10502243 | 119 | 10502317 | 120 | 10502489 | 121 | 10502857 | 123 | 1922004 | 128 | 10502764 | 132 |
| 10502508 | 114 | 10502584 | 116 | 10502244 | 119 | 10502318 | 120 | 10502490 | 121 | 10502863 | 123 | 1922005 | 128 | 10502765 | 132 |
| 10502509 | 114 | 10502585 | 116 | 10502245 | 119 | 10502319 | 120 | 10502491 | 121 | 10502864 | 123 | 10502803 | 129 | 10502766 | 132 |
| 10502510 | 114 | 10502586 | 116 | 10502246 | 119 | 10502320 | 120 | 10502492 | 121 | 10502618 | 124 | 10502804 | 129 | 10502767 | 132 |
| 10502542 | 114 | 10502587 | 116 | 10502247 | 119 | 10502321 | 120 | 10502493 | 121 | 10502619 | 124 | 10502805 | 129 | 10502769 | 132 |
| 10502543 | 114 | 10502588 | 116 | 10502248 | 119 | 10502322 | 120 | 10502494 | 121 | 10502620 | 124 | 10502806 | 129 | 10502770 | 132 |
| 10502544 | 114 | 10502589 | 116 | 10502249 | 119 | 10502323 | 120 | | | | | | | | |

CATALOGUE INDEX

| ITEM NO. | PAGE | ITEM NO. | PAGE | ITEM NO. | PAGE | ITEM NO. | PAGE | ITEM NO. | PAGE | ITEM NO. | PAGE | ITEM NO. | PAGE | ITEM NO. | PAGE |
|----------|------|----------|------|----------|------|----------|------|----------|------|----------|------|----------|------|----------|------|
| 10502775 | 132 | 1923411 | 140 | 10504395 | 144 | 10504379 | 148 | 1897214 | 153 | 10504170 | 162 | 10504140 | 165 | | |
| 10502776 | 132 | 1923412 | 140 | 10504396 | 144 | 10504380 | 148 | 1897215 | 153 | 10504171 | 162 | 10506427 | 166 | | |
| 10502777 | 132 | 1923227 | 140 | 10504363 | 144 | 10504381 | 148 | 1897346 | 153 | 10504172 | 162 | 10506428 | 166 | | |
| 10502778 | 132 | 1923286 | 141 | 10504364 | 144 | 10504634 | 149 | 1897347 | 153 | 10504173 | 162 | 10504151 | 166 | | |
| 10502779 | 132 | 1923287 | 141 | 10504365 | 144 | 10504635 | 149 | 1897348 | 153 | 10504174 | 162 | 10504157 | 166 | | |
| 10502780 | 132 | 1923289 | 141 | 10504366 | 144 | 394100 | 149 | 1897349 | 155 | 10504175 | 162 | 10504159 | 166 | | |
| 10502781 | 132 | 1923290 | 141 | 10504367 | 144 | 54125 | 149 | 1897350 | 155 | 10504176 | 162 | 10504141 | 166 | | |
| 10502782 | 132 | 1923322 | 141 | 10504397 | 144 | 10504381 | 149 | 1897361 | 155 | 10504177 | 162 | 10504142 | 166 | | |
| 10502783 | 132 | 1923323 | 141 | 10504398 | 144 | 1897453 | 152 | 1897362 | 155 | 10504178 | 162 | 10506429 | 166 | | |
| 10502784 | 132 | 1923326 | 141 | 10504399 | 144 | 1897454 | 152 | 1897363 | 155 | 10504179 | 162 | 10506430 | 166 | | |
| 10502785 | 132 | 1923328 | 141 | 10504400 | 144 | 1897455 | 152 | 1897364 | 155 | 10504180 | 162 | 10504155 | 166 | | |
| 10502786 | 132 | 1923330 | 141 | 10504401 | 144 | 1897456 | 152 | 1897365 | 155 | 10504181 | 162 | 10504158 | 166 | | |
| 10502787 | 132 | 1923332 | 141 | 10504338 | 144 | 1897457 | 152 | 1897366 | 155 | 10504182 | 163 | 10504160 | 166 | | |
| 10502788 | 132 | 1923333 | 141 | 10504339 | 144 | 1897458 | 152 | 1897368 | 155 | 10504183 | 163 | 10504146 | 166 | | |
| 10502789 | 132 | 1923334 | 141 | 10504340 | 144 | 1897459 | 152 | 1897369 | 155 | 10504184 | 163 | 10504149 | 166 | | |
| 10502790 | 132 | 1923335 | 141 | 10504344 | 144 | 1897460 | 152 | 1897370 | 155 | 10504185 | 163 | 10504144 | 166 | | |
| 10507538 | 133 | 1923337 | 141 | 10504402 | 144 | 1897461 | 152 | 1897381 | 155 | 10504186 | 163 | 10504138 | 166 | | |
| 10502089 | 133 | 1923339 | 141 | 10504341 | 144 | 1897462 | 152 | 1897382 | 155 | 10507366 | 163 | 10504139 | 166 | | |
| 10507110 | 133 | 1923340 | 141 | 10504342 | 144 | 1897463 | 152 | 1897383 | 155 | 10504187 | 163 | 10504150 | 166 | | |
| 10507111 | 133 | 1923342 | 141 | 10504343 | 144 | 1897464 | 152 | 1897384 | 155 | 10504188 | 163 | 10507365 | 167 | | |
| 10502201 | 133 | 1923344 | 141 | 10504406 | 145 | 1897465 | 152 | 1897385 | 155 | 10504189 | 163 | 10506431 | 167 | | |
| 10501938 | 134 | 1923346 | 141 | 10504368 | 145 | 1897466 | 152 | 1897386 | 155 | 10507367 | 163 | 10506432 | 167 | | |
| 10501939 | 134 | 1923348 | 141 | 10504369 | 145 | 1897467 | 152 | 1897387 | 155 | 10504190 | 163 | 10505812 | 167 | | |
| 10501940 | 134 | 1923350 | 141 | 10504370 | 145 | 1897474 | 152 | 1897388 | 155 | 10504191 | 163 | 10505813 | 167 | | |
| 10501892 | 134 | 1923352 | 141 | 10504371 | 145 | 1897475 | 152 | 1897389 | 155 | 10504192 | 163 | 10505814 | 167 | | |
| 10501893 | 134 | 1923353 | 141 | 10504372 | 145 | 1897476 | 152 | 1897390 | 155 | 10504193 | 163 | 10507846 | 167 | | |
| 10501917 | 134 | 1923354 | 141 | 10504393 | 145 | 1897477 | 152 | 1897391 | 155 | 10504194 | 163 | 10507847 | 167 | | |
| 10501918 | 134 | 1923355 | 141 | 10504394 | 145 | 1897478 | 152 | 1897392 | 155 | 10504195 | 163 | 10507848 | 167 | | |
| 10507912 | 135 | 1923356 | 141 | 10504403 | 145 | 1897479 | 152 | 1897393 | 155 | 10504196 | 163 | 10504218 | 168 | | |
| 10507900 | 135 | 1923358 | 141 | 10504404 | 145 | 1897480 | 152 | 1897394 | 155 | 10504197 | 163 | 10504219 | 168 | | |
| 10502234 | 135 | 1923359 | 141 | 10504837 | 145 | 1897468 | 152 | 1897086 | 156 | 10504198 | 163 | 10504221 | 168 | | |
| 10503992 | 135 | 1923360 | 141 | 10504838 | 145 | 1897469 | 152 | 1897087 | 156 | 10504199 | 163 | 10504222 | 168 | | |
| 10502233 | 135 | 1923361 | 141 | 10504839 | 145 | 1897470 | 152 | 1897088 | 156 | 10504200 | 163 | 10504223 | 168 | | |
| 10502570 | 136 | 1923362 | 141 | 10504840 | 145 | 1897471 | 152 | 1897089 | 156 | 10504201 | 163 | 10504224 | 168 | | |
| 10503990 | 136 | 1923364 | 141 | 10504351 | 145 | 1897472 | 152 | 1897090 | 156 | 10504202 | 163 | 10504226 | 168 | | |
| 10502569 | 136 | 1923366 | 141 | 10504352 | 145 | 1897473 | 152 | 1897191 | 156 | 10504203 | 163 | 10504227 | 168 | | |
| 10503730 | 136 | 1923368 | 141 | 10504353 | 145 | 1897395 | 153 | 1897192 | 156 | 10504204 | 163 | 10504228 | 168 | | |
| 10502604 | 136 | 1923370 | 141 | 10504354 | 145 | 1897396 | 153 | 1907698 | 156 | 10504205 | 163 | 10504229 | 168 | | |
| 10503991 | 136 | 1923321 | 141 | 10504355 | 145 | 1897397 | 153 | 1897193 | 156 | 10504206 | 163 | 10504410 | 168 | | |
| 10502603 | 136 | 1923331 | 141 | 10504356 | 145 | 1897398 | 153 | 1897194 | 156 | 10504207 | 163 | 10504545 | 168 | | |
| 10502499 | 137 | 1923338 | 141 | 10504357 | 145 | 1897426 | 153 | 1897195 | 156 | 10504208 | 163 | 10504220 | 168 | | |
| 10503989 | 137 | 1923357 | 141 | 10504373 | 145 | 1897427 | 153 | 1897196 | 156 | 10504209 | 163 | 10504225 | 168 | | |
| 10502500 | 137 | 1923502 | 141 | 10504374 | 145 | 1897428 | 153 | 1907699 | 156 | 10504210 | 163 | 10504234 | 168 | | |
| 10502504 | 137 | 1923413 | 141 | 10504375 | 145 | 1897429 | 153 | 1897197 | 156 | 10504211 | 163 | 10504231 | 168 | | |
| 10503993 | 137 | 1923414 | 141 | 10504376 | 145 | 1897430 | 153 | 1897198 | 156 | 10505818 | 163 | 10504233 | 168 | | |
| 10507720 | 137 | 1923228 | 141 | 10504358 | 145 | 1897431 | 153 | 1897199 | 156 | 10504212 | 163 | 10504230 | 168 | | |
| 10507764 | 137 | 1923229 | 141 | 10504359 | 145 | 1897432 | 153 | 1897200 | 156 | 10504213 | 163 | 10504232 | 168 | | |
| 10506627 | 138 | 1923501 | 141 | 10504360 | 145 | 1897433 | 153 | 1897201 | 156 | 10505819 | 163 | 10505815 | 169 | | |
| 10506628 | 138 | 1923419 | 142 | 10504361 | 145 | 1897434 | 153 | 1897202 | 156 | 10505820 | 163 | 10505816 | 169 | | |
| 10507604 | 138 | 1923420 | 142 | 10504362 | 145 | 1897435 | 153 | 1897203 | 156 | 10505821 | 163 | 10505817 | 169 | | |
| 10502826 | 138 | 1923431 | 142 | 10504346 | 145 | 1897436 | 153 | 1897204 | 156 | 10504532 | 163 | 10504235 | 169 | | |
| 10506629 | 138 | 1923432 | 142 | 10504347 | 145 | 1897448 | 153 | 1897205 | 156 | 10504536 | 163 | 10504288 | 169 | | |
| 10507603 | 138 | 1923433 | 142 | 10504348 | 145 | 1897449 | 153 | 1897206 | 156 | 10504533 | 163 | 10504290 | 169 | | |
| 1923372 | 140 | 1923434 | 142 | 10504349 | 145 | 1897450 | 153 | 1897207 | 156 | 10504534 | 163 | 10504291 | 169 | | |
| 1923373 | 140 | 1923435 | 142 | 10504350 | 145 | 1897451 | 153 | 1897208 | 156 | 10504535 | 163 | 10504292 | 169 | | |
| 1923375 | 140 | 1923416 | 142 | 10504383 | 145 | 1897452 | 153 | 1907772 | 156 | 10507368 | 163 | 10504295 | 169 | | |
| 1923376 | 140 | 1923417 | 142 | 10504384 | 145 | 1897437 | 153 | 1907773 | 156 | 10507235 | 163 | 10504289 | 169 | | |
| 1923377 | 140 | 1923418 | 142 | 1868193 | 146 | 1897438 | 153 | 1907774 | 156 | 10506439 | 163 | 10504293 | 169 | | |
| 1923378 | 140 | 1923436 | 143 | 1868194 | 146 | 1897439 | 153 | 1907775 | 156 | 10506440 | 163 | 10504294 | 169 | | |
| 1923381 | 140 | 1923437 | 143 | 1868195 | 146 | 1897440 | 153 | 1907777 | 156 | 10506441 | 163 | 10504297 | 169 | | |
| 1923383 | 140 | 10504387 | 144 | 1868196 | 146 | 1897441 | 153 | 1907778 | 156 | 10506442 | 163 | 10504296 | 169 | | |
| 1923385 | 140 | 10504388 | 144 | 1868197 | 146 | 1897442 | 153 | 1907779 | 156 | 10506444 | 163 | | | | |
| 1923386 | 140 | 10504389 | 144 | 1868198 | 146 | 1897443 | 153 | 1907781 | 156 | 10506445 | 163 | | | | |
| 1923387 | 140 | 10504390 | 144 | 1868199 | 146 | 1897444 | 153 | 1907782 | 156 | 10506424 | 165 | | | | |
| 1923388 | 140 | 10504391 | 144 | 1868200 | 146 | 1897445 | 153 | 10504161 | 162 | 10506425 | 165 | | | | |
| 1923391 | 140 | 10504336 | 144 | 1868251 | 147 | 1897446 | 153 | 10504162 | 162 | 10506426 | 165 | | | | |
| 1923392 | 140 | 10504330 | 144 | 1868252 | 147 | 1897447 | 153 | 10504163 | 162 | 10504147 | 165 | | | | |
| 1923405 | 140 | 10504331 | 144 | 10504385 | 148 | 1897209 | 153 | 10504164 | 162 | 10504148 | 165 | | | | |
| 1923406 | 140 | 10504332 | 144 | 10504386 | 148 | 1897210 | 153 | 10504165 | 162 | 10504152 | 165 | | | | |
| 1923407 | 140 | 10504392 | 144 | 10504382 | 148 | 1897211 | 153 | 10504166 | 162 | 10504153 | 165 | | | | |
| 1923408 | 140 | 10504333 | 144 | 1840465 | 148 | 1907700 | 153 | 10504167 | 162 | 10504154 | 165 | | | | |
| 1923409 | 140 | 10504334 | 144 | 10504377 | 148 | 1897212 | 153 | 10504168 | 162 | 10504156 | 165 | | | | |
| 1923410 | 140 | 10504335 | 144 | 10504378 | 148 | 1897213 | 153 | 10504169 | 162 | 10504143 | 165 | | | | |





MERCHANDISING SOLUTIONS TO DRIVE YOUR SALES



Leverage your store environment and maximise your sell-out with flexible in-store solutions from IRWIN®.

Ask your sales representative - NOW!

IRWIN® TOOLS

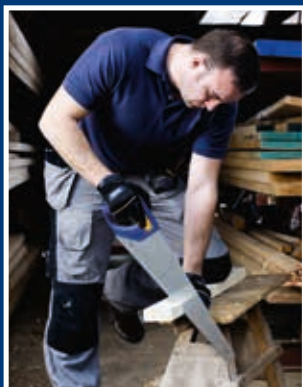

NWL Austria GmbH
Schottenring 14,
A-1010 Vienna
Austria
Tel: +43 (0)1206 09 1075

NWL Belgium B.V.B.A
Industriepark-Noord 30
Sint-Niklaas 9100
Belgium
Tel :+3227006672
Netherlands: +31707703978

**Newell Rubbermaid
Czech Republic s.r.o.**
Perlova 371/5
Prague 1, Stare Mesto 110 00
Czech Republic
Tel: +420239014996

NWL Denmark Aps
Stamholmen 155, 2nd floor
2650 Hvidovre
Denmark
Tel: +4543314956

NWL Finland Oy
c/o Asianajotoimisto DLA Piper
Finland OY Fabianinkatu 23
Helsinki 00130
Finland
Tel: +358972519252

NWL France S.A.S
738, rue Yves Kermen
Boulogne-Billancourt 92100
France
Tel: +33 (0)805 542 537

NWL Germany GmbH
Albert-Einstein-Ring 17-21
22761 Hamburg
Germany
Tel: +49 (0) 69 170 776 615

**Newell Rubbermaid
Hungary Trading Ltd.**
Csorsz u. 49-51
Budapest H-1124
Hungary
Tel: +3617779880

NWL Italy Srl
Via Benigno Crespi, 19
Palazzo Mac 4
20159 Milano
Italy
Tel: +39 (0) 029 129 4744

NWL Luxembourg S.à r.l
412F route d'Esch
L-1030
Luxembourg
Tel: +35 (0) 224 871 609

NWL Norway AS
c/o Advokatfirma DLA Piper
Norway DA
Olav Vs gate 4
Oslo 0114
Norway
Tel: + 47 (0) 23024713

Newell Poland Services Sp. z o.o.
61-894 Poznań
Plac Andersa 7
Poland
Tel: +48223060213

Rubbermaid Portugal Lda
ALargo S. Carlos, No. 3
1200-410 Lisbon
Portugal
Tel: + 351 213 665 471

Newell Spain, S.L.
Av. Burgos 12, 2ª izquienda
28036 Madrid
Spain
Tel: +34 910 507 251

Newell Rubbermaid Sweden AB
c/o DLA Nordic Box 7315
Stockholm 1039
Sweden
Tel: +0859366363

NWL Switzerland Sàrl
Chemin de Blandonnet 10
1214 Vernier
Switzerland
Tel: +41445118342/43

Newell Rubbermaid UK Limited
Halifax Avenue - Fradley Park
Lichfield Staffordshire WS 13 8SS UK
Main Tel: +44 (0) 1543 44 70 01
Customer Service Tel: 0844 412 1190,
0344 4121190
Customer Service Fax: 0844 412 1184,
0344 4121184

Sanford LLC
Letnikovskaya Street 2, Building 1,
Moscow 115114
Russian Federation
Tel: +48 61 63 98 153

**Newell Rubbermaid Kırtasiye Ticaret
ve Sanayi Limited Sirketi**
Huzur Mah Fazil Kaftanoglu Cad.
No. 7/1 Seha Is Merkezi, Seyrantepe Sisli
Istanbul, Turkey
Tel: +48 61 63 98 160

Newell Rubbermaid Middle East FZE
Dubai Airport Free Zone Building 6W
Block B, Office 640, P O Box 54554
Dubai, United Arab Emirates
Tel: +48 61 63 98 160

NWL South Africa (Pty) Limited
150 Fleming St.,
Meadowdale Gauteng 1614
South Africa
Tel: +48 61 63 98 160