



QUICK INDEX

PLIERS:

	Page No.
Angle Nose	6, 8
Battery	10
Belt Plier Pouch	12
Bent Nose Slip Joint	7
Brake Adjusting Tools	11
Brake Spring	11
Convertible Retaining Ring	14, 15
Electrical Wire Stripper	16
Hose Clamp Plier	7
Lock Ring	11
Pipe Wrench Plier	5
Plier Sets	12, 13
Retaining Ring	14, 15, 16
Slip Joint (Straight Nose)	7
Snap Ring Set	16
Solid Joint (Diagonal's, Lineman's, Needle Nose, End Nipper)	9
Toggle Lock (Standard and Long Nose)	10
Tongue & Groove (C-Joints)	4

PUNCHES & CHISELS:

Cape Chisel	19
Center Punch	21
Cold Chisel	18
Diamond Point Chisel	18
Lining Up Bar	21
Long Cold Chisel	18
Long Pin Punch	20
Long Taper Punch	20
Pin Punch	20
Prick Punch	21
Pry Bars	22
Punch & Chisel Sets	23, 24
Rivet Buster	19
Roll Spring Punch	25
Round Nose Chisel	19
Solid Punch	21

WRENCHES:

Adjustables	40
Battery Wrench	37
Combination (Fractional and Metric)	34
Ignition	35
OFF-SET Ratcheting Box	38, 39
Ratcheting Box	36, 37
Refrigeration Ratchets	37
Sockets	28, 29, 30, 31, 32, 33

SCREWDRIVERS:

4 in 1 (Miniature and Standard Size)	43
Nut Driver (Fractional and Metric)	44
Phillips	42
Screw Starters	45
Sets	43
Slotted	42
Spark Testing Screwdriver (In Wrench Section)	35
Torx®	45
Wooden Handle Slotted & Phillips	43

PLUMBING & INDUSTRIAL TOOLS:

Page No.

Aviation Snips	55
Ball Tip L-Hex Key Wrench	52
Extractors	53
Faucet Handle Pullers	48
Flaring	50
Hack Saw	51
Hammers (Claw, Ball Pein, BRASS)	53
Hex Key Sets (+Fold-up Set)	52
Hex Key Wrenches	52
Internal Pipe Wrenches	49
Metal Cutting Snips	55
Pipe Wrenches	49
Sledges	54
T-Handle Hex Key Wrench	52
Tape Measures	48
Torch Lighter	51
Tubing Cutters	50

AUTOMOTIVE TOOLS:

Ball Joint Separator	63
Feeler Gauges	35, 65
Glaze Breakers	59
Hones	58
Oil Filter Wrenches	61
Piston Ring Expander	64
Pullers	62, 63
Ring Compressors	64
Ring Groove Cleaner	64
Tie Rod End Puller	63
Valve Lifters	60, 61

SERVICE TOOLS:

Awls	71
Axle Rethreading Die	72
Battery Carrier	72
Blow Guns	68
Contact Point File	72
Cotter Key Extractors	71
Dust Cap Plier	72
Flexible Drivers	72
Headlight Spring Tool	71
Hook and Pick Set	70
Hose Clamp Pliers	72
Inspection Mirrors	69
Magnetic Pick-Up Tools	70
Mechanical Finger	70
Scrapers	71

DISPLAY BOARDS

FORMS:

Conversion Table	75
Literature Order Form	77
Logo	74
Tool Order Form	76

INDEX:

Numerical	79-80
-----------	-------

PLIERS
PUNCHES, CHISELS & PRY BARS
WRENCHES
SCREWDRIVERS
PLUMBING & INDUSTRIAL
AUTOMOTIVE
SERVICE TOOLS
DISPLAYS

THE ORIGINAL ANGLE NOSE PLIER

Some 75 years ago in Kansas City, Missouri two brothers, Paul and Otto Froeschl, thought of a new idea for the ordinary straight nose plier; angle the nose 32 degrees to create the greater leverage and gripping power that a straight nose plier is unable to give. Thus was born the original WILDE WRENCH, the first angle nose plier, granted U.S. Patent No. 1,800,447, and the beginning for the two brothers of over forty years experience in the designing and manufacturing of pliers and other quality hand tools.

During this time, the name WILDE has become synonymous with fine quality hand tools and for many years our trademark was



"THE PLIERSMITHS™". The original WILDE WRENCH is as practical and useful today as it was over fifty years ago, a testimony to the soundness of the idea and the design which produced the first angle nose plier.

Today, the third and fourth generation offspring of the founders are still in the business of producing quality pliers and other hand tools. The original WILDE WRENCH is still available, together now with a wide variety of other pliers and hand tools shown in this catalog.

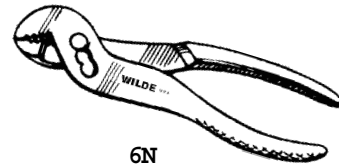

6N

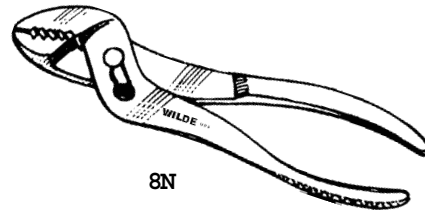

8N

THE **WILDE**® LINE
THE **WITCO**® LINE



Wilde Tool offers a complete line of Slip Joint Pliers. All pliers are drop forged from our own special alloy steel. Precision heat treating assures the toughest tool available. Some pliers are also available in Industrial Black.

Our pliers are finished with one of two finishes. The **WILDE**® line is full polished. The **WITCO**® line is the same precision pliers as the **WILDE**® line with polishing operations eliminated to make these pliers attractive in price without sacrificing quality. Comfortable plastic fluorescent orange grips are standard equipment on all **WITCO**® pliers.



PLIERS

WILDE® WITCO® UNDERCUT TONGUE & GROOVE PLIERS

Jaws are milled with deep, self-gripping pipe wrench style teeth. Accurately machined tongue fits and pivots in any of the precision machine grooves eliminating strain and wear on the bolt.

See page 4. Plier Set Page 12.

WILDE® WITCO® SLIP JOINT PLIERS BENT, THIN & STRAIGHT NOSE

Extra hard, deep, sharply cut teeth for greater grip and longer wear.

Lobster claw teeth design provides two gripping sections, one is extra wide for large objects, the other for small work. All pliers have hardened alloy steel bolt and all have shear wire cutters.

See Page 7. Plier Set Page 12.

WILDE® WITCO® ANGLE NOSE PLIERS

Jaws are milled with deep, self-gripping pipe wrench style teeth. Hardened bolts. The 10" and 11" are equipped with Grip Tight Clips™ which pull the bolt into positive alignment in slot when plier is under pressure. The 11" has notch in teeth which fits vertical rib on basket strainer nut as well as hub caps and dust covers.

Includes Wilde Wrench, the original angle nose plier.

See Pages 6, 8. Plier Set Page 12.

LOCK RING PLIERS

These solid joint pliers spread snap lock rings on brakes, transmissions, farm equipment and machine tools. Drop forged and polished jaws. Jaws are scored on outside to hold rings securely. Points are not guaranteed.

See Page 11.

BELT PLIER POUCH. See Page 12.

LOCKING PLIERS. See Page 10.

BRAKE SPRING PLIERS. See Page 11.

BRAKE ADJUSTERS. See Page 11.



NEW HEAVY DUTY PIPE WRENCH PLIER®

UNDERCUT Tongue & Grooves. Jaws are offset 90°. 20% more leverage. Forged from alloy steel. Heavy duty construction. Fully heat treated. Reach where other pliers will not go.

See Page 5. DISPLAY SETS - Page 13.

HOSE CLAMP PLIER

Produced from our 8" style slip joint plier. Plastic grips. Lobster claw style offers gripping section and has shear type cutter. 3 tools in one.

See Page 7.

SOLID JOINT PLIERS

Forged from selected steel, individually paired tempered, adjusted and tested. Keen cutting edge. Polished face with plastic grips.

See Page 9.

BATTERY PLIERS

Fixed joint self-gripping plier. Three sets of teeth engage the work giving additional holding power on round rods or worn battery bolts. Plastic grips. Polished jaw.

See Page 10.

RETAINING RING PLIERS

For easy removal or installing retaining rings over shafts or in boxes. Internal or external. Straight tips or bent.

See Pages 14, 15, & 16.

CONVERTIBLE RETAINING RING PLIER

Accurate alignment for tough alloy steel replaceable tips. Precision plier jaws and pivot. Push button convertible from ext. to int. action. Spring return plier handles. Five color coded pairs of tips in sizes .036, .047, and .070 straight and bent 90° in a small durable plastic pouch with hex wrench. Master pouch for convenient storage. Heavy duty cushion grips.

See Page 15. Plier Sets Page 16.

PLIERS

PUNCHES, CHISELS & PRY BARS

WRENCHES

SCREWDRIVERS

PLUMBING & INDUSTRIAL

AUTOMOTIVE

SERVICE TOOLS

DISPLAYS

WILDE® WITCO® TONGUE & GROOVE PLIERS

PLASTIC GRIPPED HANDLES ARE INTENDED FOR COMFORT & FIRM GRIP. THEY ARE NOT INTENDED FOR PROTECTION AGAINST ELECTRIC SHOCK.

MACHINED UNDERCUT TONGUE & GROOVES RE-ENFORCEMENT WEBS

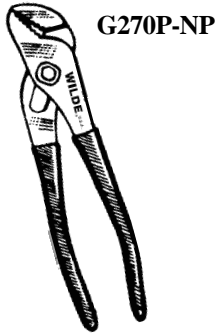

G270P-NP

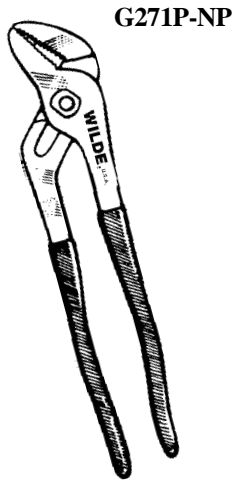

G271P-NP

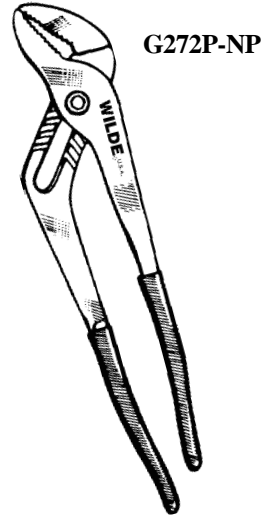

G272P-NP

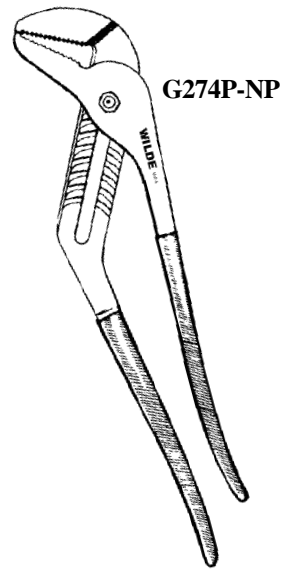

G274P-NP

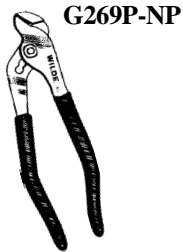

G269P-NP

WILDE® NATURAL FINISH. FULL POLISHED.

CAT. NO.	OAL	# OF ADJUST- MENTS	MAX. PAR. JAW OPENING	INFORMATION	GRIPS	# OF MAX. PAR. STD. CARDED PACK	
						PACK	STD.
G269P-NP	5"	3	1/2"	T&G Ignition Plier	Red	X	10
G270P-NP	7"	5	7/8"	General Purpose	Red	X	10
G271P-NP	10"	5	1-1/2"	Most Popular	Red	X	5
G272P-NP	12-3/4"	7	2-5/8"	When size is needed	Red	X	4
G274P-NP	16"	11	4-1/4"	Even more size	Red		1
G276P-NP	20-1/4"	14	5-3/4"	3-1/4" Throat Depth	Red		Available Soon

WITCO® INDUSTRIAL BLACK. SATIN FINISHED.



G269B

G269B	5"	3	1/2"	T&G Ignition Plier	Flourescent Orange	X	10
G270B	7"	5	7/8"	General Purpose	Flourescent Orange	X	10
G271B	10"	5	1-1/2"	Most Popular	Flourescent Orange	X	5
G272B	12-3/4"	7	2-5/8"	When size is needed	Flourescent Orange	X	4
G274B	16"	11	4-1/4"	Even more size	Flourescent Orange	X	1
G276B	20-1/4"	14	5-3/4"	3-1/4" Throat Depth	Flourescent Orange		Available Soon



G270B



G271B



G272B

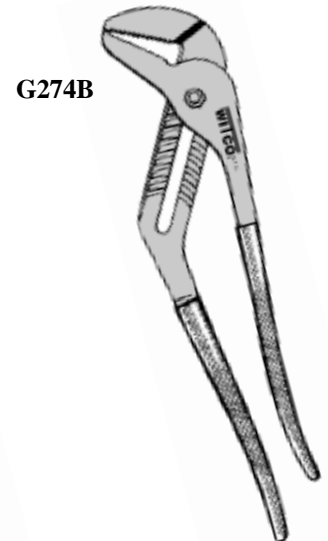

G274B

PLIERS
PUNCHES, CHISELS & PRY BARS
WRENCHES
SCREWDRIVERS
PLUMBING & INDUSTRIAL
AUTOMOTIVE
SERVICE TOOLS
DISPLAYS

WILDE® WITCO® PIPE WRENCH PLIERS®

PLASTIC GRIPPED HANDLES ARE INTENDED FOR COMFORT & FIRM GRIP. THEY ARE NOT INTENDED FOR PROTECTION AGAINST ELECTRIC SHOCK.

Pipe Wrench Plier®

MACHINED UNDERCUT TONGUE & GROOVES RE-ENFORCEMENT WEBS

G295P-NP

G295's are with Smooth Jaws

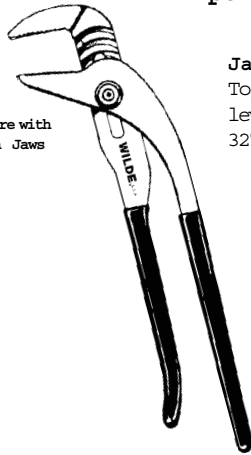

Pipe Wrench Style Teeth

Jaws Angle 90°
To Create up to 20% more leverage than conventional 32° angled jaws.

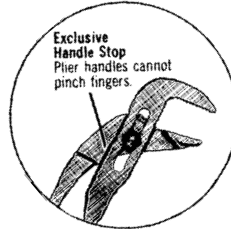

Exclusive Handle Stop
Plier handles cannot pinch fingers.

G297P-NP

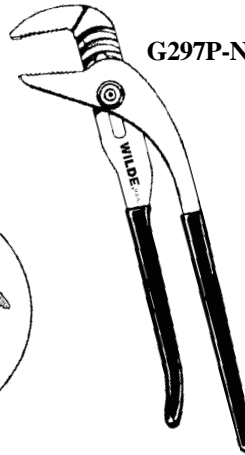

G299P-NP

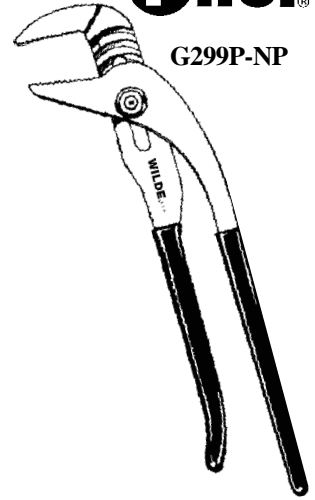

G293P-NP



WILDE® NATURAL FINISH. FULL POLISHED.

CAT. NO.	OAL	# OF ADJUST- MENTS	MAX. PAR. JAW OPENING	MACHINED T&G GRIPS		STD. CARDED	PACK
				Undercut	Red		
G293P-NP	7"	4	7/8"	Undercut	Red	X	10
G295P-NP	10"	7	2-1/8"	Undercut-Smooth Jaw	Red	X	5
G297P-NP	10"	7	2-1/8"	Undercut	Red	X	5
G299P-NP	12-3/4"	7	2-5/8"	Undercut	Red	X	5

WITCO® INDUSTRIAL BLACK. SATIN FINISHED.

G293B



G293B
G295B
G297B
G299B

7"
10"
10"
12-3/4"

4
5
5
7

7/8"
2-1/8"
2-1/8"
2-5/8"

Undercut
Undercut-Smooth Jaw
Undercut
Undercut

Flourescent Orange
Flourescent Orange
Flourescent Orange
Flourescent Orange

X
X
X
X

10
5
5
5

G295B



G295's are with Smooth Jaws

G297B



G299B



PLIERS
PUNCHES, CHISELS & PRY BARS
WRENCHES
SCREWDRIVERS
PLUMBING & INDUSTRIAL
SERVICE TOOLS
AUTOMOTIVE
DISPLAYS

WILDE® WITCO® ANGLE NOSE SLIP JOINT PLIERS

PLASTIC GRIPPED HANDLES ARE INTENDED FOR COMFORT & FIRM GRIP. THEY ARE NOT INTENDED FOR PROTECTION AGAINST ELECTRIC SHOCK.

NOTCHED:
Fits Vertical Rib Basket Strainer Nut.

Also Auto Hub Dust Covers & Hub Caps.

GRIP TIGHT CLIP™

G251P-NP

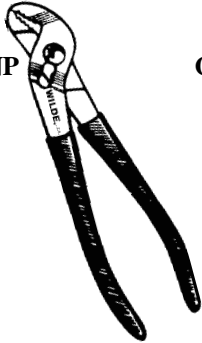

G252P-NP

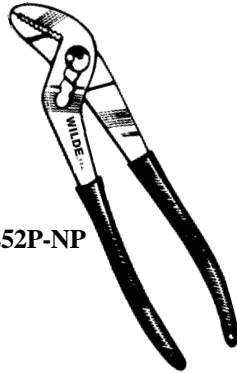

G253P-NP

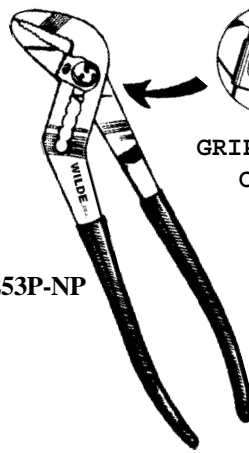

G254P-NP

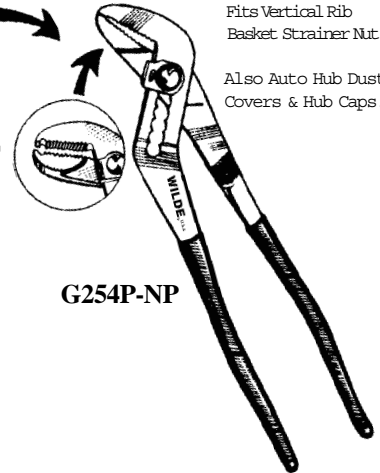

WILDE® NATURAL FINISH. FULL POLISHED.

G250P-NP

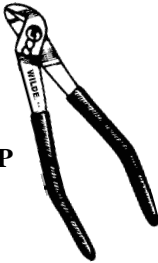

CAT NO.	# OF ADJUST- MENTS	MAX. PAR. JAW OPENING	PLIERS: ANGLE		STD. CARDED PACK
			NOSE SLIP JOINT	GRIPS	
G250P-NP	5"	3	1/2"	Ignition.	Red X 10
G251P-NP	6-3/4"	3	3/4"	All Purpose.	Red X 10
G252P-NP	8"	4	1-1/8"	All Purpose.	Red X 10
G253P-NP	10"	7	2-1/8"	Water Pump.	Red X 5
G254P-NP	11"	7	2-1/8"	Notched Nose.	Red X 5

WITCO® INDUSTRIAL BLACK. SATIN FINISHED.

G250B



G250B	5"	3	1/2"	Ignition.	Flourescent Orange	X	10
G251B	6-3/4"	3	3/4"	All Purpose.	Flourescent Orange	X	10
G252B	8"	4	1-1/8"	All Purpose.	Flourescent Orange	X	10
G253B	10"	7	2-1/8"	Water Pump.	Flourescent Orange	X	5
G254B	11"	7	2-1/8"	Notched Nose.	Flourescent Orange	X	5

GRIP TIGHT CLIP™

G251B



G252B



G253B

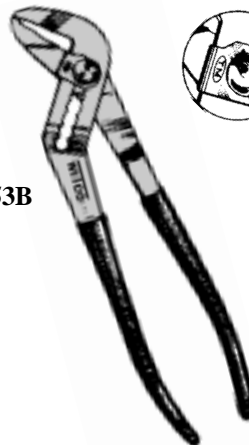

G254B

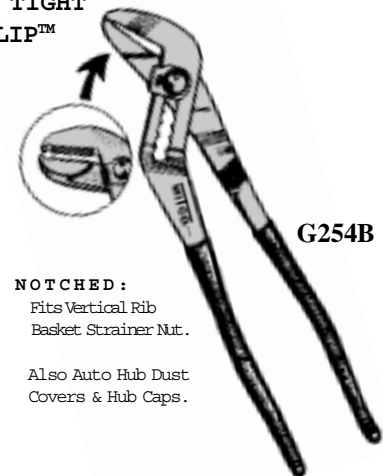

NOTCHED:
Fits Vertical Rib Basket Strainer Nut.

Also Auto Hub Dust Covers & Hub Caps.

WILDE® WITCO® COMBINATION/SLIP JOINT PLIERS

PLASTIC GRIPPED HANDLES ARE INTENDED FOR COMFORT & FIRM GRIP.
THEY ARE NOT INTENDED FOR PROTECTION AGAINST ELECTRIC SHOCK.

All pliers with
SHEAR TYPE CUTTERS



On all pliers on this page



G261BP-NP

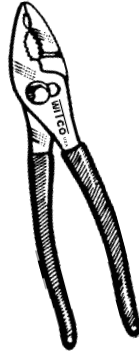

G262P-NP

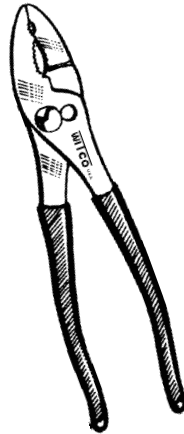

G263P-NP

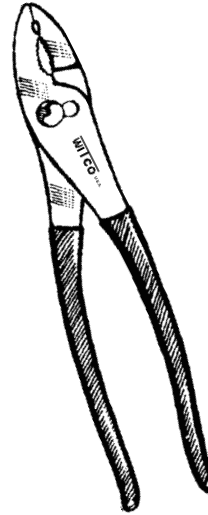

G264P-NP

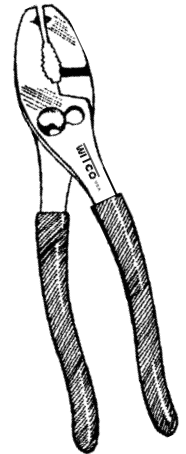

G260P-NP

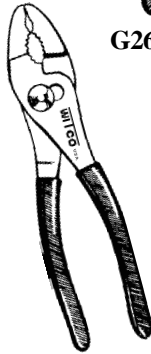

G261TP-NP

WILDE® NATURAL FINISH. FULL POLISHED.

CAT NO.	OAL	# OF ADJUST-MENTS	ADDITIONAL INFORMATION	GRIPS	STANDARD CARDED	PACK
G261TP-NP	6-1/2"	2	THIN NOSE.	Red	X	10
G261BP-NP	6-1/2"	2	BENT NOSE.	Red	X	10
G262P-NP	6-1/2"	2	Shear Type Cutter.	Red	X	10
G263P-NP	8"	2	Shear Type Cutter	Red	X	10
G264P-NP	10"	2	Shear Type Cutter	Red	X	5
G260P-NP	8"	2	HOSE CLAMP.	Red	X	10

WITCO® INDUSTRIAL BLACK. SATIN FINISHED.



G261TB

G261TB	6-1/2"	2	THIN NOSE.	Flourescent Orange	X	10
G261BB	6-1/2"	2	BENT NOSE.	Flourescent Orange	X	10
G262B	6-1/2"	2	Shear Type Cutter.	Flourescent Orange	X	10
G263B	8"	2	Shear Type Cutter	Flourescent Orange	X	10
G264B	10"	2	Shear Type Cutter	Flourescent Orange	X	5
G260B	8"	2	HOSE CLAMP.	Flourescent Orange	X	10



G261BB



G262B



G263B



G264B



G260B



WILDE® KNURLED HANDLE & SMOOTH JAW ANGLED NOSE SLIP JOINT PLIERS

PLASTIC GRIPPED HANDLES ARE INTENDED FOR COMFORT & FIRM GRIP.
THEY ARE NOT INTENDED FOR PROTECTION AGAINST ELECTRIC SHOCK.

PLIERS
PUNCHES, CHISELS & PRY BARS
WRENCHES
SCREWDRIVERS
PLUMBING & INDUSTRIAL
AUTOMOTIVE
SERVICE TOOLS
DISPLAYS

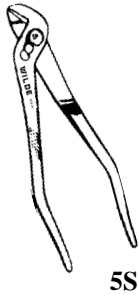

5S

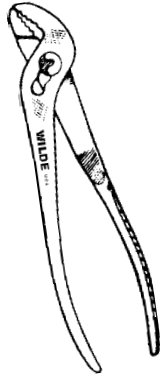

7G

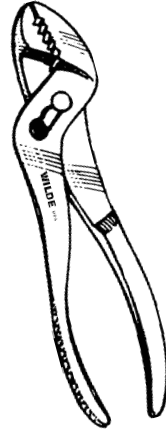

8N
G8N

ORIGINAL WILDE WRENCH

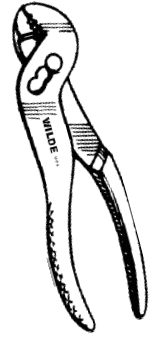

6N
G6N

WILDE® NATURAL FINISH.

CAT NO.	OAL	# OF ADJUST- MENTS	MAX. PAR. JAW OPENING	INFORMATION	HANDLE	STD. CARDED	PACK
5S	5"	3	1/2"	Full Polish. Ignition.	Plain Handle	X	10
7G	6-3/4"	3	3/4"	Full Polish.	Knurled	X	10
				All Purpose Plier.			
6N	6"	3	7/8"	Full Polish.	Knurled	X	10
G6N	6"	3	7/8"	Full Polish.	Gripped	X	10
8N	8"	3	1-1/8"	Full Polish.	Knurled	X	10
G8N	8"	3	1-1/8"	Full Polish.	Gripped	X	10
10S	10"	7	2-1/8"	Satin Finish.	Knurled	X	5
				Water Pump Plier w/ GRIP TIGHT CLIP™			
11S	11"	7	2-1/8"	Satin Finish.	Knurled	X	5
				Water Pump Plier w/ GRIP TIGHT CLIP™			
G428N-NP	10"	7	2-1/8"	Smooth Jaw.	Red Grips	X	5
				Full Polish.			
				Water Pump Plier w/ GRIP TIGHT CLIP™			

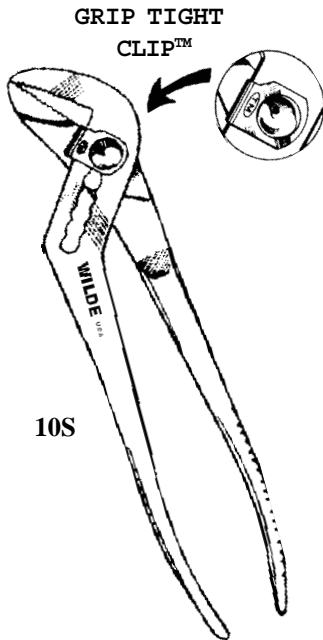

10S

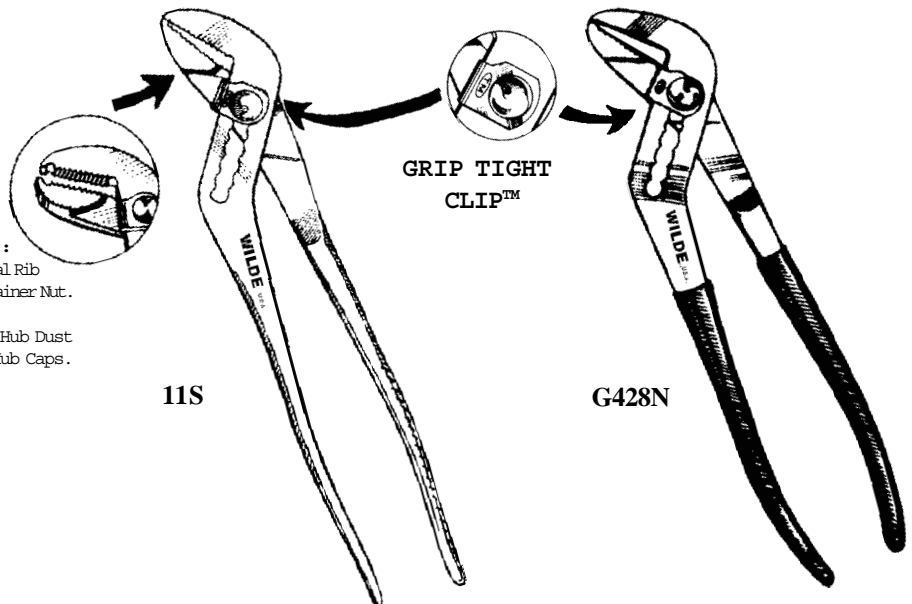

11S

G428N

NOTCHED :
Fits Vertical Rib
Basket Strainer Nut.

Also Auto Hub Dust
Covers & Hub Caps.

WILDE® SOLID JOINT PLIERS

PLASTIC GRIPPED HANDLES ARE INTENDED FOR COMFORT & FIRM GRIP.
THEY ARE NOT INTENDED FOR PROTECTION AGAINST ELECTRIC SHOCK.

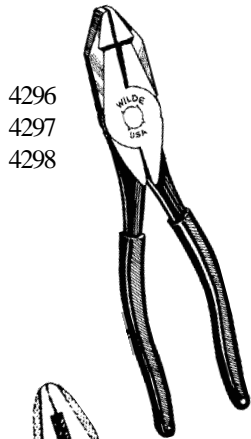

4296
4297
4298

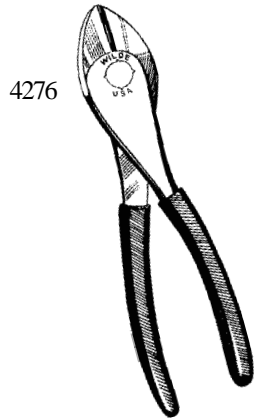

4276

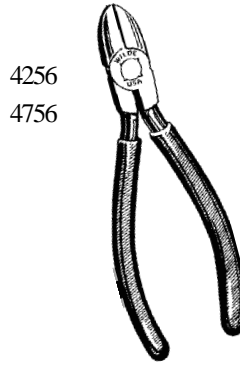

4256
4756

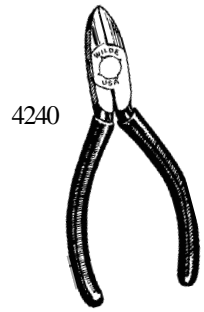

4240

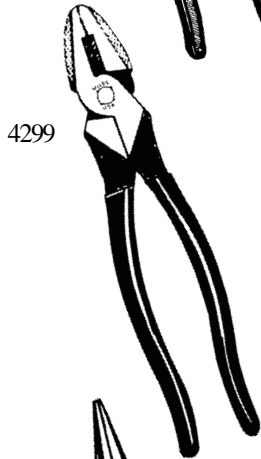

4299



4225



4227



4226

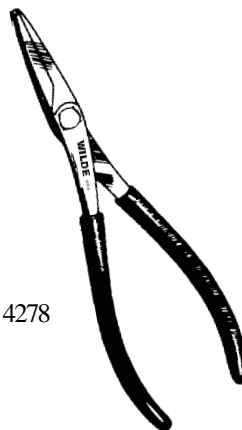

4278

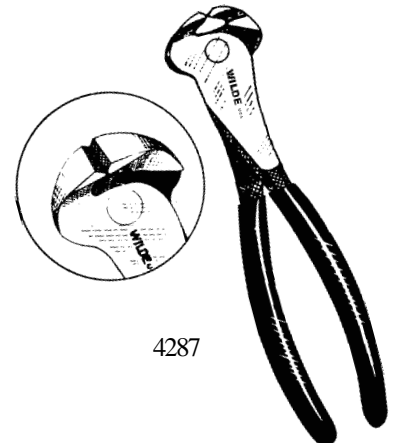

4287

WILDE® NATURAL FINISH.

CAT NO.	OAL	INFORMATION	GRIPS	STANDARD	STD. CARDED PACK	STD. 10
4240	4-3/4"	Diagonal Cutting Plier.	Red	X	10	10
4256	6"	Diagonal Cutting Plier.	Red	X	10	10
4756	7-1/2"	Diagonal Cutting Plier.	Red	X	10	10
4276	7"	Heavy Duty Diagonal Cutting Plier.	Red	X	10	10
4296	6-1/2"	Lineman's Plier.	Red	X	10	10
4297	7-1/4"	Lineman's Plier.	Red	X	10	10
4298	8-1/2"	Lineman's Plier	Red	X	10	10
4299	9"	Lineman's NEW ENGLAND style High Leverage.	Red	X	10	10
4225	5"	Short Needle Nose Plier w/ Cutter .	Red	X	10	10
4227	6-1/2"	Needle Nose Plier w/ Cutter .	Red	X	10	10
4226	6"	CURVED Needle Nose Plier.	Red	X	10	10
4278	7-3/4"	Duck Bill Plier.	Red	X	10	10
4287	7"	End Nippers.	Red	X	10	10

PLIERS
PUNCHES, CHISELS & PRY BARS
WRENCHES
SCREWDRIVERS
PLUMBING & INDUSTRIAL
AUTOMOTIVE
SERVICE TOOLS
DISPLAYS



WILDE® BATTERY & LOCKING PLIERS

PLASTIC GRIPPED HANDLES ARE INTENDED FOR COMFORT & FIRM GRIP.
THEY ARE NOT INTENDED FOR PROTECTION AGAINST ELECTRIC SHOCK.

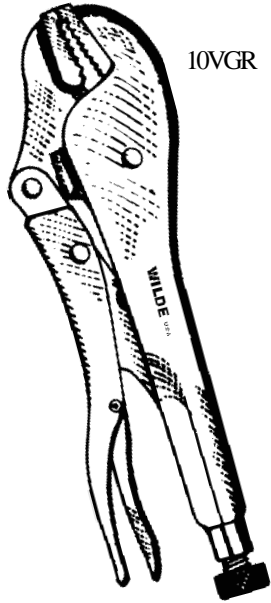

10VGR

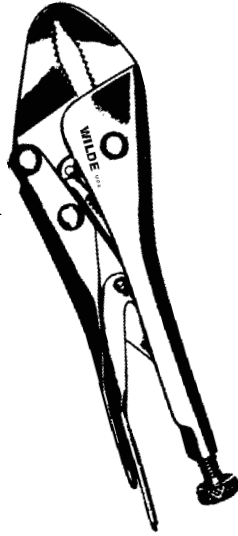

7VGR



G410B

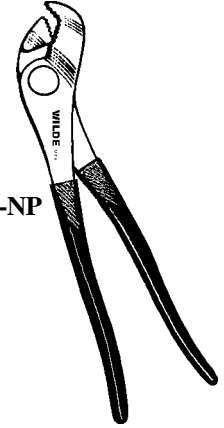

G410P-NP

WILDE®

CAT. NO.	OAL	INFORMATION	GRIPS	STANDARD	STOCKED
				PACK	
G410P-NP	7-1/2"	Battery Plier. Fixed Joint. 3 Sets of Teeth. Full Polished. Natural Finish.	Red	X	10
G410B	7-1/2"	Battery Plier. Fixed Joint. 3 Sets of Teeth. Full Polished. Industrial Black.	Red	X	10
7VGR	7"	Locking Toggle Loc Plier. Plated. Thin involute jaws will grip rounds up to 1" diameter.		X	5
10VGR	10"	Locking Toggle Loc Plier. Plated. 1-1/4" Maximum Opening.		X	5
4VGR	4"	Long Nose Locking Toggle Loc Plier w/Cutter. Plated. Reaches into close quarters.		X	5
6VGR	6"	Long Nose Locking Toggle Loc Plier w/Cutter. Plated. Reaches into close quarters.		X	5
9VGR	9"	Long Nose Locking Toggle Loc Plier w/Cutter. Plated. Reaches into close quarters.		X	5

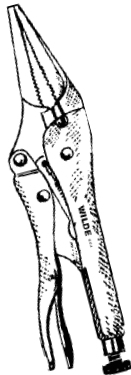

4VGR

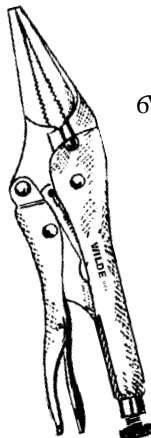

6VGR

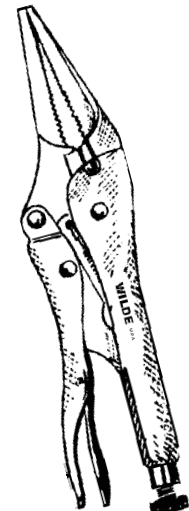

9VGR

PLIERS

PUNCHES, CHISELS & PRY BARS

WRENCHES

SCREWDRIVERS

PLUMBING & INDUSTRIAL

AUTOMOTIVE

SERVICE TOOLS

DISPLAYS

WILDE® LOCK RING PLIERS & BRAKE TOOLS

PLASTIC GRIPPED HANDLES ARE INTENDED FOR COMFORT & FIRM GRIP.
THEY ARE NOT INTENDED FOR PROTECTION AGAINST ELECTRIC SHOCK.

Heavy Duty with parallel action jaws feature compound leverage action. Spring action closes jaws. Thin jaws are notched to securely hold snap lock rings as they open in a parallel plane. Used on transmissions, brakes and machine tools.

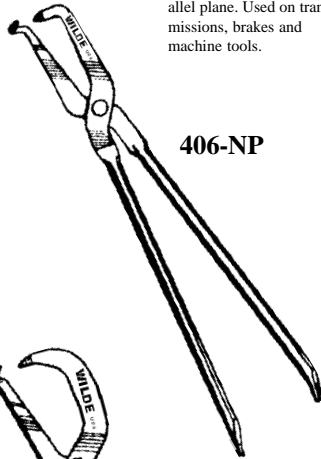

406-NP

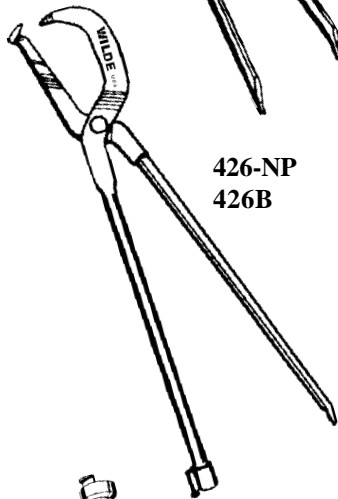

426-NP
426B

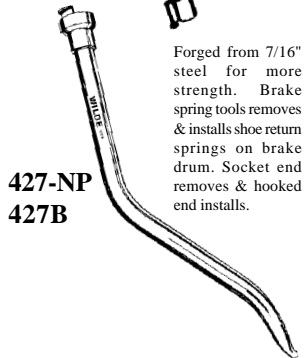

427-NP
427B

Forged from 7/16" steel for more strength. Brake spring tool removes & installs shoe return springs on brake drum. Socket end removes & hooked end installs.

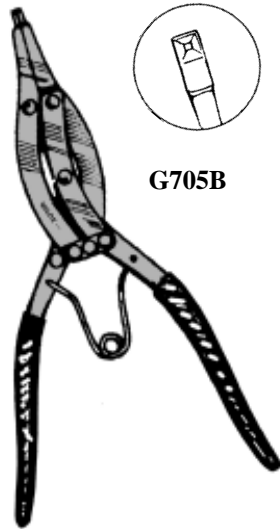

G705B

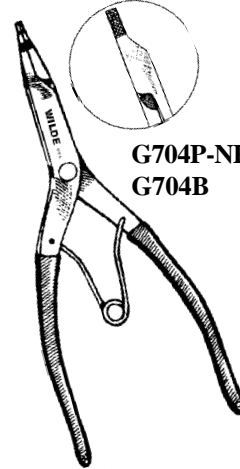

G704P-NP
G704B

Lock Ring Pliers are single piece drop forging for strength. Spreads, removes & installs ring w/o holes. Deep knurled jaws hold rings. Spring action closes jaw used on brakes, transmissions, pedal shifts, clutch shafts & machine tools. Can also be used to spread piston rings.

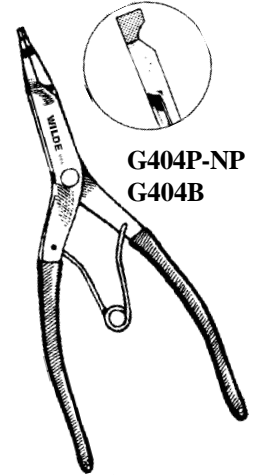

G404P-NP
G404B

WILDE® NATURAL FINISH.

CAT NO.	OAL	OPENING	INFORMATION	GRIPS	CARDED	STD. PACK
G404P-NP	9"	1-1/2"	Right Angle Tip Lock Ring Plier.	Red	X	5
G704P-NP	9"	1-1/2"	Straight Tip Lock Ring Plier.	Red	X	5
406-NP	13-1/2"		Brake Spring Plier		X	5
426-NP	14"		Bendix Brake Spring Plier.		X	5
427-NP	9"		Brake Spring Tool. Socket & Spoon End.		X	10
587T-NP	8"		Brake Adjuster.		X	10
577-NP	8"		Brake Adjuster.		X	10
577T-NP	6-3/4"		Brake Adjuster w/Notch Portion.		X	10

INDUSTRIAL BLACK

G404B	9"	1-1/2"	Right Angle Tip Lock Ring Plier.	Flourescent Orange	X	5
G704B	9"	1-1/2"	Straight Tip Lock Ring Plier.	Flourescent Orange	X	5
G705B	10"		Compound Lev. Lock Ring Plier.	Red	X	5
426B	14"		Bendix Brake Spring Plier.		X	5
427B	9"		Brake Spring Tool. Socket & Spoon End.		X	10
587TB	8"		Brake Adjuster.		X	10
577B	8"		Brake Adjuster.		X	10
577TB	6-3/4"		Brake Adjuster w/Notch Portion.		X	10

Adjusts clearance between brake drum & brake shoe. Fits through slot in backing plate & turns star wheel. Heads are offset for hard to reach areas.

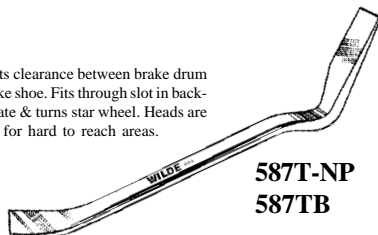

587T-NP
587TB

Angled blade with NOTCHED portion. Heads are offset for hard to reach areas.

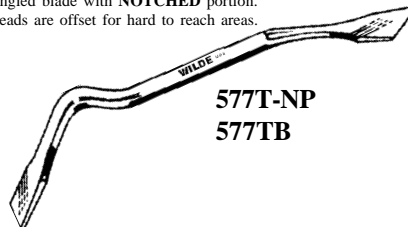

577T-NP
577TB

Designed to adjust brakes where space is limited.

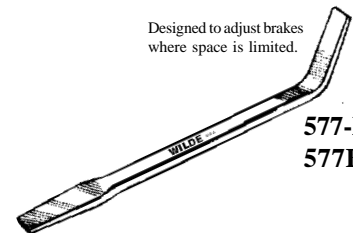

577-NP
577B



WORK SAFELY WITH HAND TOOLS — WEAR SAFETY GOGGLES —

PLIERS
PUNCHES, CHISELS & PRY BARS
WRENCHES
SCREWDRIVERS
PLUMBING & INDUSTRIAL
AUTOMOTIVE
SERVICE TOOLS
DISPLAYS

WILDE® PLIER SETS

Cat.
No.

Description

St.
Pk.

PLASTIC GRIPPED HANDLES ARE INTENDED FOR COMFORT & FIRM GRIP.
THEY ARE NOT INTENDED FOR PROTECTION AGAINST ELECTRIC SHOCK.



G259SPD

2-Piece Clear Hang-Up Vinyl Pouch Set. This All-Purpose set consists of one each G271P-NP Tongue and Groove Plier & G262P-NP Combination/Slip Joint Plier. **NATURAL FINISH.**

2 Pcs.
10/Pk.

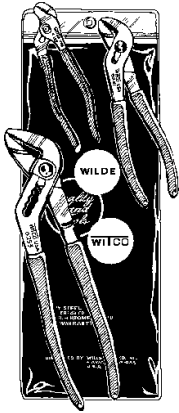

G256SPD

3-Piece Clear Hang-Up Vinyl Pouch Set. Set consists of one each G250P-NP, G251P-NP and G253P-NP Slip Joint Angle Nose Pliers. **NATURAL FINISH.**

3 Pcs.
10/Pk.

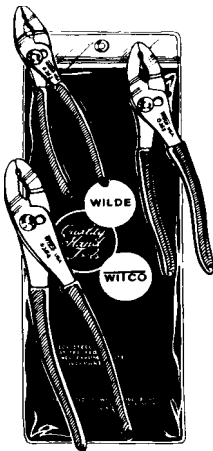

G258SPD

3-Piece Clear Hang-Up Vinyl Pouch Set. Set consists of one each G262P-NP, G263P-NP & G264P-NP Combination/Slip Joint Pliers. **NATURAL FINISH.**

3 Pcs.
10/Pk.

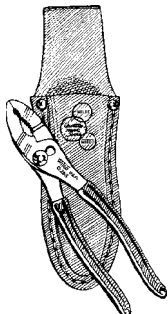

A67

Belt Plier Pouch Only. **Heavy Duty** top grain leather. Tunnel belt loop fits 2-1/8" belt. Double rivet reinforcement.

10

#A67 Pouch Fits All Tools On Page 7.

PLIERS

PUNCHES, CHISELS
& PRY BARS

WRENCHES

SCREWDRIVERS

PLUMBING &
INDUSTRIAL

AUTOMOTIVE

SERVICE TOOLS

DISPLAYS



PIPE WRENCH PLIER® SETS

Cat. No.

Description

St. Pk.

PLASTIC GRIPPED HANDLES ARE INTENDED FOR COMFORT & FIRM GRIP.
THEY ARE NOT INTENDED FOR PROTECTION AGAINST ELECTRIC SHOCK.

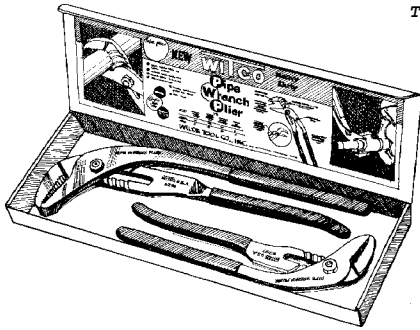

G292SPB

2-Piece Display Box.
Set consists of one
G297P-NP and G299P-NP
PIPE WRENCH PLIER®
NATURAL FINISH.

2 Pcs.
10/Pk.

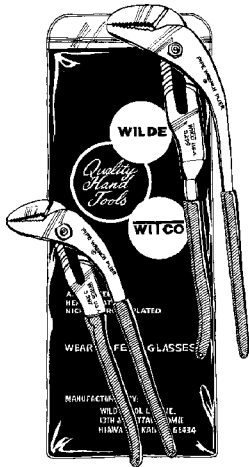

G292SPD

2-Piece Clear Hang-Up.
Vinyl Pouch Set.
Set consists of one
G297P-NP and G299P-NP
PIPE WRENCH PLIER®
NATURAL FINISH.

2 Pcs.
10/Pk.



G297SP

20-Piece Display Box.
10"-90° Pipe Wrench Plier® .
7 Machined Tongue & Groove
adjustments. Maximum
parallel jaw opening 2-1/8".
Plastic Grips.
NATURAL FINISH.

20
Pcs.



G299SP

15-Piece Display Box.
12-3/4"-90° Pipe Wrench
Plier® . 7 Machined
Tongue & Groove adjustments.
Maximum parallel jaw
opening 2-5/8".
Plastic Grips.
NATURAL FINISH

20
Pcs.

PLIERS

PUNCHES, CHISELS
& PRY BARS

WRENCHES

SCREWDRIVERS

PLUMBING &
INDUSTRIAL

AUTOMOTIVE

SERVICE TOOLS

DISPLAYS



PLIERS- WILDE®

Cat. No.	Description	St. Pk.
----------	-------------	---------

PLIERS
PUNCHES, CHISELS & PRY BARS
WRENCHES
SCREWDRIVERS
PLUMBING & INDUSTRIAL
AUTOMOTIVE
SERVICE TOOLS
DISPLAYS

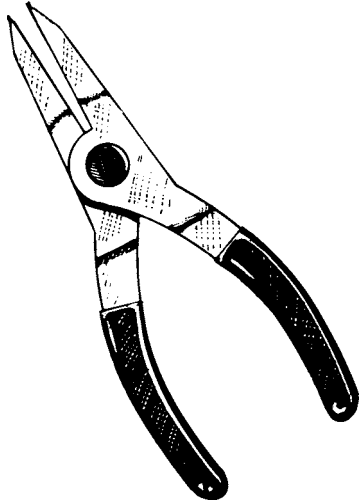

520	Internal Retaining Ring Plier. .022 Tip dia.	5
520A	Internal Retaining Ring Plier. .022 Tip dia. 45°	5
520B	Internal Retaining Ring Plier. .022 Tip dia. 90°	5
521	Internal Retaining Ring Plier. .038 Tip dia.	5
521A	Internal Retaining Ring Plier. .038 Tip dia. 45°	5
521B	Internal Retaining Ring Plier. .038 Tip dia. 90°	5
522	External Retaining Ring Plier. .038 Tip dia.	5
522A	External Retaining Ring Plier. .038 Tip dia. 45°	5
522B	External Retaining Ring Plier. .038 Tip dia. 90°	5
523	Internal Retaining Ring Plier. .070 Tip dia.	5
523A	Internal Retaining Ring Plier. .070 Tip dia. 45°	5
523B	Internal Retaining Ring Plier. .070 Tip dia. 90°	5
524	External Retaining Ring Plier. .070 Tip dia.	5
524A	External Retaining Ring Plier. .070 Tip dia. 45°	5
524B	External Retaining Ring Plier. .070 Tip dia. 90°	5
525	Internal Retaining Ring Plier. .090 Tip dia.	5
525A	Internal Retaining Ring Plier. .090 Tip dia. 45°	5
525B	Internal Retaining Ring Plier. .090 Tip dia. 90°	5
526	External Retaining Ring Plier. .115 Tip dia.	5
526A	External Retaining Ring Plier. .115 Tip dia. 45°	5
526B	External Retaining Ring Plier. .115 Tip dia. 90°	5

Convertible Retaining Ring Pliers

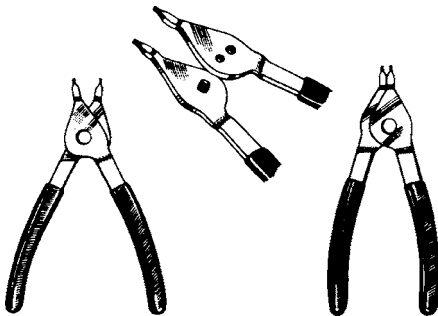

	Tip Size	Tip Angle	OAL	
527	.038	Straight	6"	5
527A	.038	45°	6"	5
527B	.038	90°	6"	5
528	.047	Straight	6"	5
528A	.047	45°	6"	5
528B	.047	90°	6"	5
534	.070	Straight	7-3/4"	5
534A	.070	45°	7-3/4"	5
534B	.070	90°	7-3/4"	5
535	.090	Straight	9-1/2"	5
535A	.090	45°	9-1/2"	5
535B	.090	90°	9-1/2"	5

PLIERS- WILDE®

Cat. No.	Description	St. Pk.
----------	-------------	---------

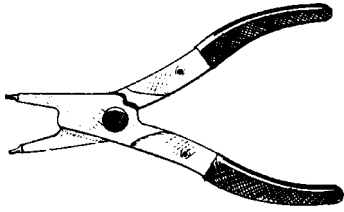

542	External Retaining Ring Plier. Spring loaded. Angle tips, size .045.	10
-----	--	----

TO BE DISCONTINUED
WHEN STOCK
IS DEPLETED

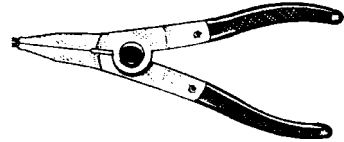

563	Internal Retaining Ring Plier. Spring loaded. Straight tips, size .060.	10
-----	---	----

564	External Retaining Ring Plier. Spring loaded. Straight tips, size .060.	10
-----	---	----

PLIERS

PUNCHES, CHISELS & PRY BARS

WRENCHES

SCREWDRIVERS

PLUMBING & INDUSTRIAL

AUTOMOTIVE

SERVICE TOOLS

DISPLAYS

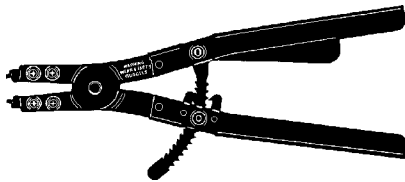

517	Internal Retaining Ring Plier 15-11/16" long. Tip dia. .120. Tips opened 3-3/16". Tips closed 11/16".	3
-----	---	---

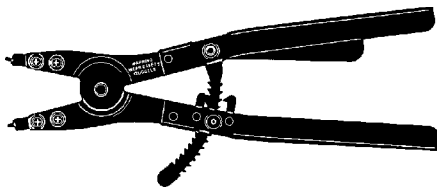

518	External Retaining Ring Plier 15-3/4" long. Tip dia. .120. Tips opened 3-1/8". Tips closed 1/2".	3
-----	--	---

517TS	Replacement Tips-Straight	5
517T-45	Replacement Tips-45°	5
517T-90	Replacement Tips-90°	5

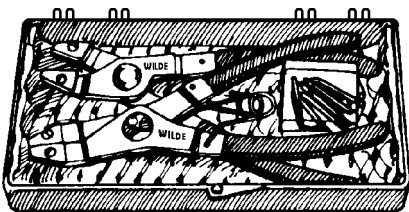

444K	Snap Ring Plier Set. 1 Pair Tips Each .038 Black-Straight, 15°, 45° & 90°. .047 Silver-Straight, 45° & 90°. .070 Gold-Straight.	10
------	--	----

444T	Tips Only for 444K	5
------	--------------------	---

444I	Internal Plier with tips.	5
------	---------------------------	---

444E	External Plier with tips.	5
------	---------------------------	---

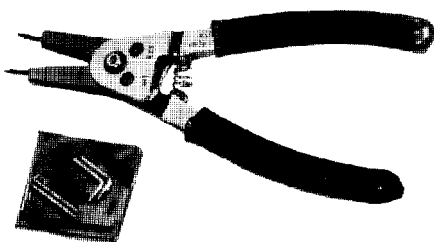

1234	Convertible Retaining Ring Plier. Ext. sizes 1/4" thru 2". Int. sizes 3/8" thru 2".	5
------	---	---

1214	Replacement Tips for #1234 .036 Black-Straight & 90°. .047 Silver-Straight & 90°. .070 Copper-Straight.	5
------	--	---



PLIERS

Cat.
No.

Description

St.
Pk.

540

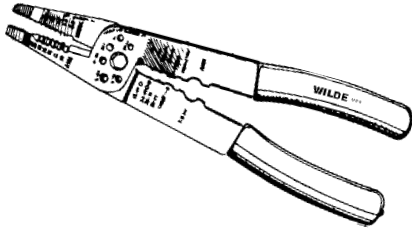

Electrical Wire Stripper - AWG 5 & Metric, Full 1/2" Scissor Type Cutting Blades - Stripping Stations for 22 to 10 and .5MM to 5.3MM - Perfect Rethread Bolt Cutting on 6/32 - 8/32 - 10/32 plus 3.5MM, 4MM, 5MM. Crimping of both Insulated and Non-insulated Terminals - also 7-8MM Auto Ignition - Overall Length of 9-1/2" provides proper leverage - complete with air cushion vinyl grips.

541



Electrical Wire Stripper. AWG & Metric. Automatic return spring. Convenient handle lock. Hardened Steel pivot bushing. Wire sizes are embossed in metal. Strip sizes: AWG 20 to 10 Metric 0.8 to 2.6

537

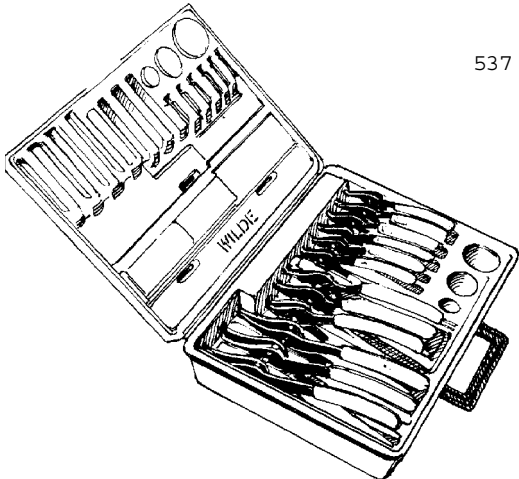

Professional Dozen - Retaining Ring Plier Kit. Kit covers complete range of rings from approximately 1/4" to 3-1/2" of both Internal and External types - 12 convertible pliers tip diameters .038 - .047 - .070 - .090 with straight - 45° and 90° bend. (Takes the place of 24 individual models.) Comfortable vinyl grips - packed in shock resistant plastic case with storage space for spare rings complete with carrying handle. Weight - 5-1/2 pounds.

538

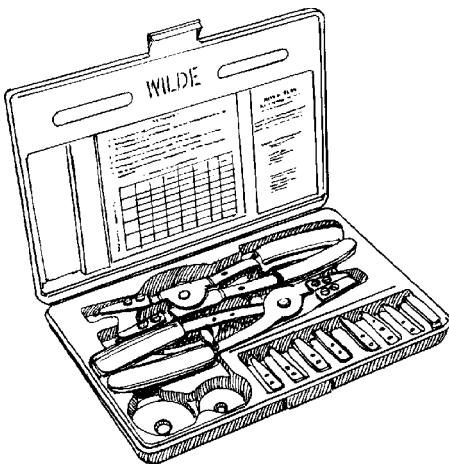

Heavy Duty Plier Set. Includes Replaceable Tip Retaining Ring Pliers with spring, ratchet lock assembly, 27R (Internal) and 28R (External) in form fit plastic storage case with spaces for spare rings. Kit contains eight (8) pairs of tips - Diameter .108 Black: Straight - 15° - 45° - 90°; also .120 Silver: Straight - 15° - 45° - 90° - tips are mounted directly to the pliers for maximum stability - Pliers 9-1/2" long, black oxide finish and red air cushion grips - two pliers take the place of sixteen (16) separate pliers. Weight - 2-1/2 pounds.

PLIERS

PUNCHES, CHISELS & PRY BARS

WRENCHES

SCREWDRIVERS

PLUMBING & INDUSTRIAL

AUTOMOTIVE

SERVICE TOOLS

DISPLAYS



HEX STOCK PUNCHES & CHISELS

NEW NATURAL FINISH & INDUSTRIAL BLACK PLATE

COLD CHISELS
LONG COLD CHISELS
CAPE CHISELS
ROUND NOSE CHISELS
DIAMOND POINT CHISELS

RIVET BUSTER
PIN PUNCHES
LONG PIN PUNCHES
CENTER PUNCHES
PRICK PUNCHES

SOLID PUNCHES
LONG TAPER PUNCHES
LINING UP BARS
PRY BARS

PRY BARS with Handles (Industrial Black)
AND A
COMPLETE LINE OF
PUNCH & CHISEL SETS

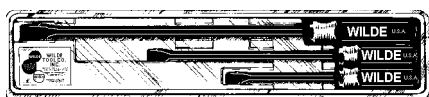

ROLL SPRING PUNCHES

Each Wilde Roll Spring Punch has a pilot point that fits into the hollow center of the pin, holding the driving shoulder of the punch in perfect contact position. Pins are quickly and easily removed without damage to wall of hole or pin.

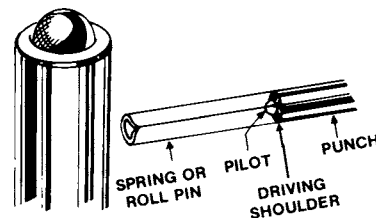

PUNCHES, CHISELS & PRY BARS

All punches and chisels are forged from High Carbon Molybdenum Tool Steel. Properly heat treated to make these tools the toughest on the market. Punches and Chisels are hardened the entire length with tempered striking end. The heads and points are full polished, stock is satin finished for positive grip. The cutting edges are sharpened and re-sharpened to give the keenest points available. The punches are centerless ground to ensure complete accuracy. **Pin punches have a reverse taper point which eliminates the punch from sticking in the work piece.**

Thirteen popular sets are available packaged in sturdy vinyl pouches.

When looking for quality punches and chisels, professionals look for **WILDE**.

PROPER USE

Punches and Chisels are designed to be resharpened once they become dull. Care should be taken that excessive heat is not obtained when re-sharpening. If the grinding temperature is not controlled the hardness can be taken out of the immediate area. More importantly a hard, brittle surface can be set up which is very susceptible to fracture.

Always wear **safety goggles** when using punches and chisels.

Pin punches are designed to drive a work piece out only after the work piece has been started out with a solid or long taper punch - avoid side pressure.

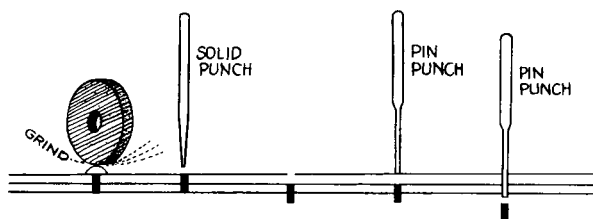

PLIERS
PUNCHES, CHISELS & PRY BARS
WRENCHES
SCREWDRIVERS
PLUMBING & INDUSTRIAL
AUTOMOTIVE
SERVICE TOOLS
DISPLAYS

CHISELS

HEX STOCK

Cat. No.

Cut

Length Approx.

Stock Size

St. Pk.

COLD CHISELS

NATURAL FINISH

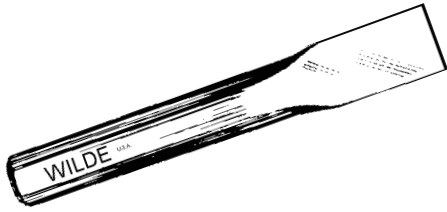

CC832	1/4	4-3/4	1/4	20
CC1032	5/16	5	5/16	20
CC1232	3/8	5-1/4	5/16	20
CC1432	7/16	5-1/2	3/8	20
CC1632	1/2	6	3/8	20
CC2032	5/8	6-1/2	1/2	15
CC2432	3/4	7	5/8	10
CC2832	7/8	7-1/2	3/4	10
CC3232	1	8	7/8	5
CC3632	1-1/8	8	7/8	5

INDUSTRIAL BLACK

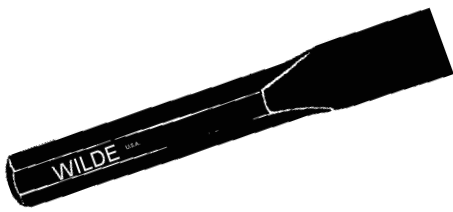

CC832B	1/4	4-3/4	1/4	20
CC1032B	5/16	5	5/16	20
CC1232B	3/8	5-1/4	5/16	20
CC1432B	7/16	5-1/2	3/8	20
CC1632B	1/2	6	3/8	20
CC2032B	5/8	6-1/2	1/2	15
CC2432B	3/4	7	5/8	10
CC2832B	7/8	7-1/2	3/4	10
CC3232B	1	8	7/8	5
CC3632B	1-1/8	8	7/8	5

EXTRA LENGTH COLD CHISELS

NATURAL FINISH

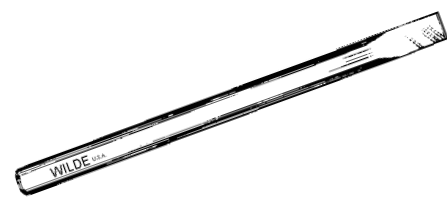

CCL1632	1/2	12	3/8	10
CCL2032	5/8	12	1/2	10
CCL2432	3/4	12	5/8	5
CCL2432-14	3/4	14	5/8	5
CCL2432-18	3/4	18	5/8	5
CCL2832	7/8	12	3/4	5
CCL3232	1	12	7/8	5
CCL3232-18	1	18	7/8	5

INDUSTRIAL BLACK

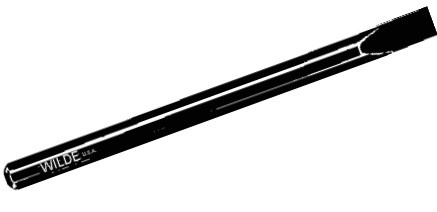

CCL1632B	1/2	12	3/8	10
CCL2032B	5/8	12	1/2	10
CCL2432B	3/4	12	5/8	5
CCL2432-14B	3/4	14	5/8	5
CCL2432-18B	3/4	18	5/8	5
CCL2832B	7/8	12	3/4	5
CCL3232B	1	12	7/8	5
CCL3232-18B	1	18	7/8	5

DIAMOND POINT CHISEL

NATURAL FINISH

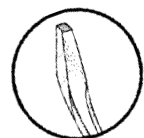

CD432	1/8	4-1/2	1/4	20
CD532	5/32	5	5/16	20
CD632	3/16	5	3/8	20
CD832	1/4	6	3/8	20
CD1032	5/16	6	1/2	20
CD1232	3/8	6-1/2	5/8	10
CD1632	1/2	7	3/4	10
CD2032	5/8	8	7/8	5

INDUSTRIAL BLACK

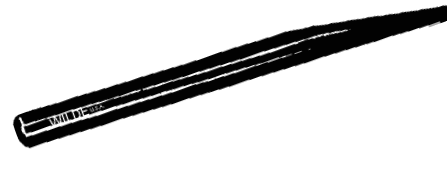

CD432B	1/8	4-1/2	1/4	20
CD532B	5/32	5	5/16	20
CD632B	3/16	5	3/8	20
CD832B	1/4	6	3/8	20
CD1032B	5/16	6	1/2	20
CD1232B	3/8	6-1/2	5/8	10
CD1632B	1/2	7	3/4	10
CD2032B	5/8	8	7/8	5

Diamond Point Chisels

Designed to cut V-grooves & clean out inside corners.

PLIERS
PUNCHES, CHISELS & PRY BARS
WRENCHES
SCREWDRIVERS
PLUMBING & INDUSTRIAL
AUTOMOTIVE
SERVICE TOOLS
DISPLAYS

CHISELS	HEX STOCK	Cat. No.	Cut	Length Approx.	Stock Size	St. Pk.
----------------	------------------	-----------------	------------	-----------------------	-------------------	----------------

CAPE CHISELS

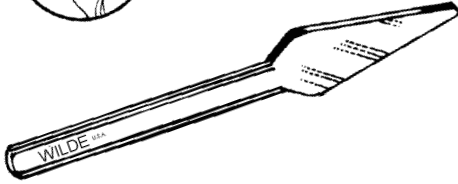

NATURAL FINISH

CP632	3/16	5	1/4	20
CP732	7/32	5	5/16	20
CP832	1/4	5-1/2	3/8	20
CP1032	5/16	6	3/8	20
CP1232	3/8	6-1/2	1/2	20

Cape Chisels
Designed for cutting keyways, slots, and grooves in metal.

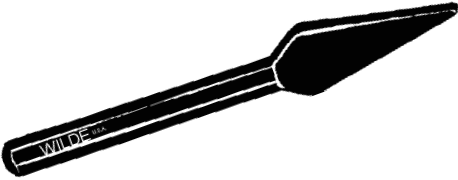

INDUSTRIAL BLACK

CP632B	3/16	5	1/4	20
CP732B	7/32	5	5/16	20
CP832B	1/4	5-1/2	3/8	20
CP1032B	5/16	6	3/8	20
CP1232B	3/8	6-1/2	1/2	20

ROUND NOSE CHISELS

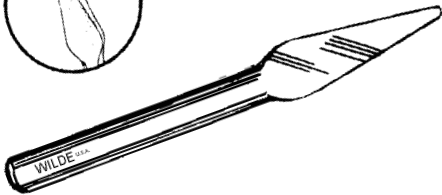
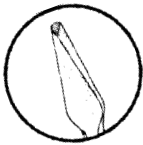

NATURAL FINISH

CR432	1/8	4-1/2	1/4	20
CR632	3/16	5	1/4	20
CR732	7/32	5	5/16	20
CR832	1/4	5-1/2	3/8	20
CR1032	5/16	6	3/8	10
CR1232	3/8	6-1/2	1/2	10
CR1632	1/2	8	3/4	10

Round Nose Chisels
aka Half Round Chisels.
Designed for cutting grooves in metal where an oval or U shape is desired.



INDUSTRIAL BLACK

CR432B	1/8	4-1/2	1/4	20
CR632B	3/16	5	1/4	20
CR732B	7/32	5	5/16	20
CR832B	1/4	5-1/2	3/8	20
CR1032B	5/16	6	3/8	10
CR1232B	3/8	6-1/2	1/2	10
CR1632B	1/2	8	3/4	10

RIVET BUSTER



NATURAL FINISH

RB2432	3/4	12	5/8	10
--------	-----	----	-----	----



INDUSTRIAL BLACK

RB2432B	3/4	12	5/8	10
---------	-----	----	-----	----



PUNCHES

HEX STOCK

Cat. No.

Cut

Length Approx.

Stock Size

St. Pk.

PIN PUNCHES

NATURAL FINISH

PP232	1/16	4-1/4	5/16	20
PP564	5/64	4-1/2	5/16	20
PP332	3/32	4-3/4	5/16	20
PP432	1/8	5	5/16	20
PP532	5/32	5-1/4	5/16	20
PP632	3/16	5-1/2	5/16	20
PP732	7/32	7	3/8	20
PP832	1/4	7	3/8	20
PP1032	5/16	7	1/2	20
PP1232	3/8	7	1/2	20

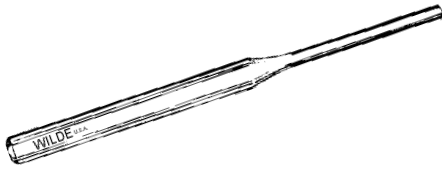

INDUSTRIAL BLACK

PP232B	1/16	4-1/4	5/16	20
PP564B	5/64	4-1/2	5/16	20
PP332B	3/32	4-3/4	5/16	20
PP432B	1/8	5	5/16	20
PP532B	5/32	5-1/4	5/16	20
PP632B	3/16	5-1/2	5/16	20
PP732B	7/32	7	3/8	20
PP832B	1/4	7	3/8	20
PP1032B	5/16	7	1/2	20
PP1232B	3/8	7	1/2	20

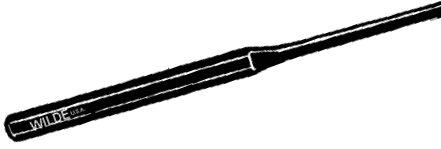

LONG PIN PUNCHES

NATURAL FINISH

PPL432	1/8	8	5/16	20
PPL532	5/32	8	5/16	20
PPL632	3/16	9	1/2	20
PPL732	7/32	9	1/2	20
PPL832	1/4	9	1/2	20
PPL1032	5/16	9	1/2	20
PPL1232	3/8	9	1/2	20

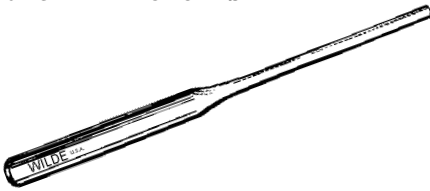

INDUSTRIAL BLACK

PPL432B	1/8	8	5/16	20
PPL532B	5/32	8	5/16	20
PPL632B	3/16	9	1/2	20
PPL732B	7/32	9	1/2	20
PPL832B	1/4	9	1/2	20
PPL1032B	5/16	9	1/2	20
PPL1232B	3/8	9	1/2	20

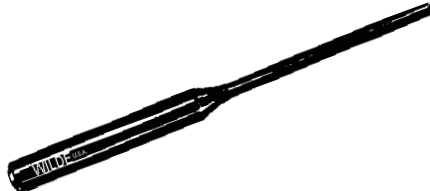

LONG TAPER PUNCHES

NATURAL FINISH

PLT232	1/16	7	3/8	20
PLT332	3/32	7-1/2	3/8	20
PLT432	1/8	8	3/8	20
PLT532	5/32	8-1/2	1/2	20
PLT632	3/16	9	1/2	20
PLT732	7/32	9-1/2	1/2	20
PLT832	1/4	11	5/8	10
PLT932	9/32	11	5/8	10
PLT1032	5/16	11	5/8	10
PLT1232	3/8	11	3/4	5

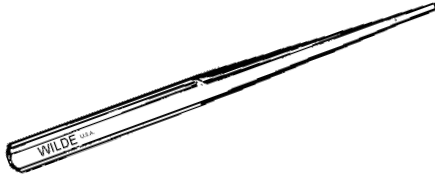

INDUSTRIAL BLACK

PLT232B	1/16	7	3/8	20
PLT332B	3/32	7-1/2	3/8	20
PLT432B	1/8	8	3/8	20
PLT532B	5/32	8-1/2	1/2	20
PLT632B	3/16	9	1/2	20
PLT732B	7/32	9-1/2	1/2	20
PLT832B	1/4	11	5/8	10
PLT932B	9/32	11	5/8	10
PLT1032B	5/16	11	5/8	10
PLT1232B	3/8	11	3/4	5

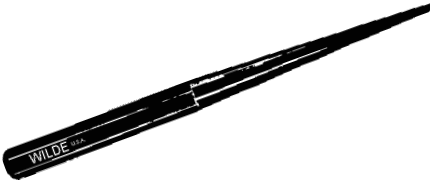

PLIERS
PUNCHES, CHISELS & PRY BARS
WRENCHES
SCREWDRIVERS
PLUMBING & INDUSTRIAL
AUTOMOTIVE
SERVICE TOOLS
DISPLAYS

PUNCHES

HEX STOCK

Cat. No.

Cut

Length Approx.

Stock Size

St. Pk.

CENTER PUNCHES

NATURAL FINISH



PC832		4-1/4	1/4	20
PC1032		4-1/2	5/16	20
PC1232		5	3/8	20
PC1432		5-1/2	7/16	20
PC1632		6	1/2	10
PC2032		7	5/8	10

INDUSTRIAL BLACK

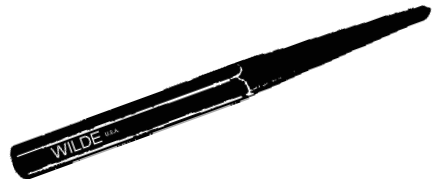

PC832B		4-1/4	1/4	20
PC1032B		4-1/2	5/16	20
PC1232B		5	3/8	20
PC1432B		5-1/2	7/16	20
PC1632B		6	1/2	10
PC2032B		7	5/8	10

PRICK PUNCHES

NATURAL FINISH

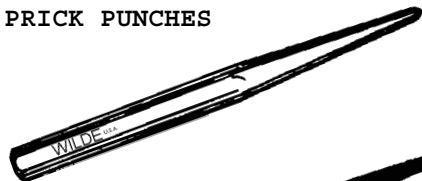

PR832		4-1/4	1/4	20
PR1032		4-1/2	5/16	20
PR1232		5	3/8	20
PR1632		6	1/2	10

INDUSTRIAL BLACK

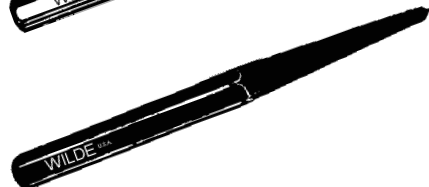

PR832B		4-1/4	1/4	20
PR1032B		4-1/2	5/16	20
PR1232B		5	3/8	20
PR1632B		6	1/2	10

SOLID PUNCHES

NATURAL FINISH

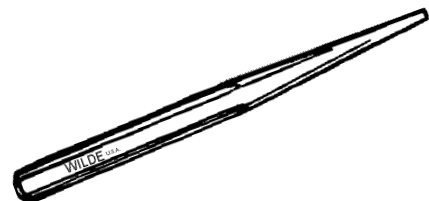

PS232	1/16	4-1/2	5/16	20
PS332	3/32	4-1/2	5/16	20
PS432	1/8	4-1/2	5/16	20
PS532	5/32	5	3/8	20
PS632	3/16	5	3/8	20
PS732	7/32	5-1/2	1/2	20
PS832	1/4	6	1/2	20
PS1032	5/16	7	5/8	10
PS1232	3/8	8	3/4	10

INDUSTRIAL BLACK

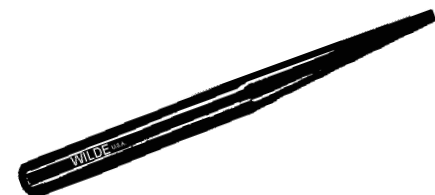

PS232B	1/16	4-1/2	5/16	20
PS332B	3/32	4-1/2	5/16	20
PS432B	1/8	4-1/2	5/16	20
PS532B	5/32	5	3/8	20
PS632B	3/16	5	3/8	20
PS732B	7/32	5-1/2	1/2	20
PS832B	1/4	6	1/2	20
PS1032B	5/16	7	5/8	10
PS1232B	3/8	8	3/4	10

LINING UP BAR

NATURAL FINISH

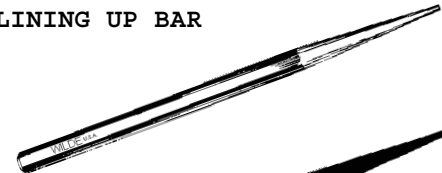

LB632	3/16	12	3/8	20
LB732	7/32	14	1/2	20
LB832	1/4	16	5/8	20
LB1032	5/16	18	3/4	5

INDUSTRIAL BLACK



LB632B	3/16	12	3/8	20
LB732B	7/32	14	1/2	20
LB832B	1/4	16	5/8	20
LB1032B	5/16	18	3/4	5

PLIERS
PUNCHES, CHISELS & PRY BARS
WRENCHES
SCREWDRIVERS
PLUMBING & INDUSTRIAL
AUTOMOTIVE
SERVICE TOOLS
DISPLAYS



PRY BARS	HEX STOCK	Cat. No.	Length Approx.	Stock Size	St. Pk.
----------	-----------	----------	----------------	------------	---------

JIMMY PRY BARS

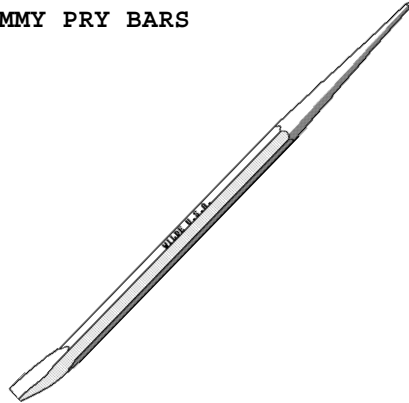

NATURAL FINISH	
JB1632	14 1/2 5
JB2032	16 5/8 5
JB2432	20 3/4 5
JB2432-24	24 3/4 5
JB2832	30 7/8 5
INDUSTRIAL BLACK	
JB1632B	14 1/2 5
JB2032B	16 5/8 5
JB2432B	20 3/4 5
JB2432-24B	24 3/4 5
JB2832	30 7/8 5

PLIERS

PUNCHES, CHISELS & PRY BARS

WRENCHES

PRY BARS

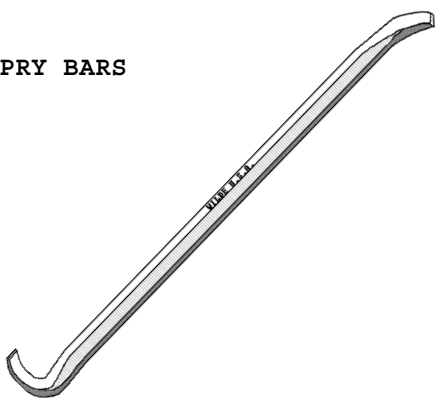

NATURAL FINISH	
PB2032	18 5/8 1
PB2432	24 3/4 1
INDUSTRIAL BLACK	
PB2032B	18 5/8 1
PB2432B	24 3/4 1

SCREWDRIVERS

ROLLING HEAD PRY BARS

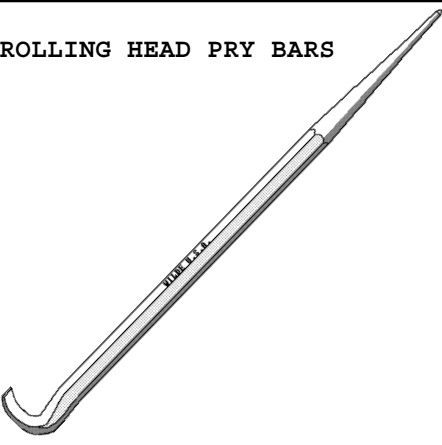

NATURAL FINISH	
RH1232-9	9 3/8 5
RH1632-12	12 1/2 5
RH1632	15 1/2 5
RH2032	18 5/8 5
INDUSTRIAL BLACK	
RH1232-9B	9 3/8 5
RH1632-12B	12 1/2 5
RH1632B	15 1/2 5
RH2032B	18 5/8 5

PLUMBING & INDUSTRIAL

AUTOMOTIVE

PRY BARS with HANDLE INDUSTRIAL BLACK



	CUT	EXPOSED	OVERALL	STOCK	
HPB1232-7B	5/8	7	12	3/8	3
HPB1232-12B	5/8	12	17	3/8	3
HPB1632-18B	11/16	18	25	1/2	3
HPB1632-24B	11/16	24	31	1/2	3
HPB2032-28B	7/8	28	36	5/8	3

SERVICE TOOLS

PRY BAR SET

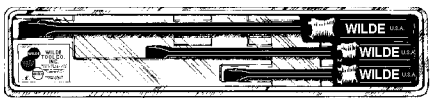

HPB3B	3-Piece Pry Bar Set with Handle. Packaged in molded tray with clear lid. Set consists of 1 each:	1
HPB1232-7B	HPB1232-12B	HPB1632-18B

DISPLAYS

PUNCH & CHISEL SETS - HEX STOCK



CC5

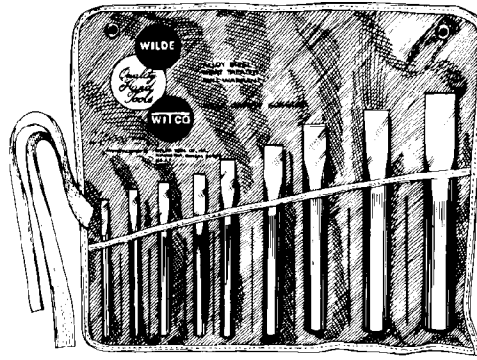

CC9



CCL4



PP5



PPL4



PLT5

Cat. No.	Description	St. Pk.
CC5	5-Piece Cold Chisel Set in a clear, sturdy, zipper seal hang-up vinyl pouch. Set consists of 1 each: CC1032 CC1232 CC1632 CC2032 CC2432	5
CC9	9-Piece Cold Chisel Set in a sturdy roll kit vinyl pouch. Set consists of 1 each: CC832 CC1032 CC1232 CC1432 CC1632 CC2032 CC2432 CC2832 CC3232	1
CCL4	4-Piece Long Cold Chisel Set in a clear, sturdy, zipper seal hang-up vinyl pouch. Set consists of 1 each: CCL2032 CCL2432 CCL2832 CCL3232	5
PP5	5-Piece Pin Punch Set in a clear, sturdy, zipper seal hang-up vinyl pouch. Set consists of 1 each: PP332 PP432 PP532 PP632 PP832	5
PPL4	4-Piece Long Pin Punch Set in a clear, sturdy, zipper seal hang-up vinyl pouch. Set consists of 1 each: PPL632 PPL832 PPL1032 PPL1232	5
PLT5	5-Piece Long Taper Punch Set in a clear, sturdy, zipper seal hang-up vinyl pouch. Set consists of 1 each: PLT432 PLT532 PLT632 PLT732 PLT832	5

PLIERS
PUNCHES, CHISELS & PRY BARS
WRENCHES
SCREWDRIVERS
PLUMBING & INDUSTRIAL
AUTOMOTIVE
SERVICE TOOLS
DISPLAYS



PUNCH & CHISEL SETS - HEX STOCK



G6



K5

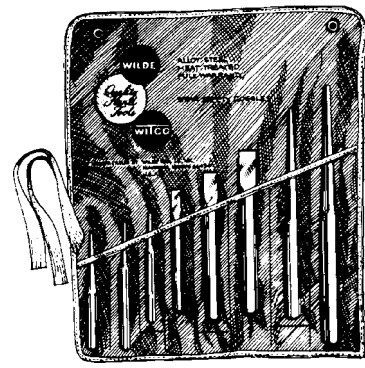

K8

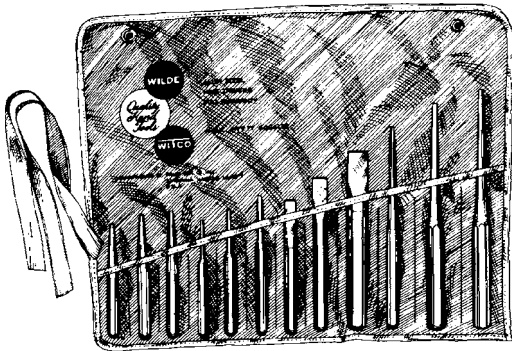

K12

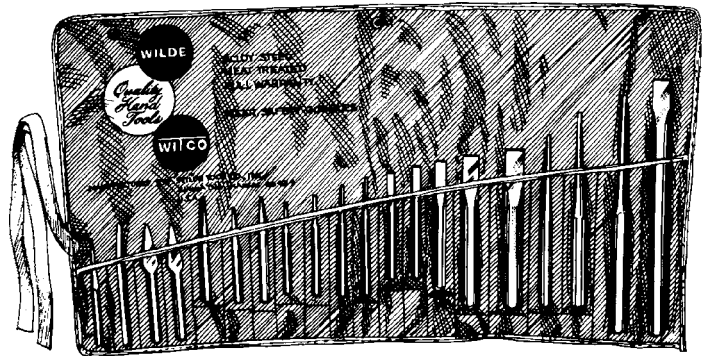

K20

Cat. No.	Description	St. Pk.
G6	6-Piece GUNSMITH Set in a clear, sturdy, zipper seal hang-up vinyl pouch. Set consists of 1 each: PC832 PP232 PP564 PP332 PP432 PS332	5
K5	5-Piece Punch & Chisel Set in a clear, sturdy, zipper seal hang-up vinyl pouch. Set consists of 1 each: CC1232 CC2032 PC1232 PP632 PS632	5
K8	8-Piece Punch & Chisel Set in a sturdy roll kit vinyl pouch. Set consists of 1 each: CC1232 CC2032 CC2432 PC1232 PP432 PP632 PLT632 PLT832	1
K12	12-Piece Punch & Chisel Set in a sturdy roll kit vinyl pouch. Set consists of 1 each: CC1232 CC1632 CC2432 PC1232 PP332 PP432 PP632 PLT432 PLT632 PLT732 PR1232 PS432	1
K20	20-Piece Master Mechanics Punch & Chisel Set in a sturdy roll kit vinyl pouch. Set consists of 1 each: CC1032 CC1232 CC1632 CC2432 CC2832 CCL2432 CD832 CP832 CR832 PC1232 PP332 PP432 PP532 PP632 PLT432 PLT632 PLT832 PR1232 PS332 PS632	1

PLIERS
PUNCHES, CHISELS & PRY BARS
WRENCHES
SCREWDRIERS
PLUMBING & INDUSTRIAL
AUTOMOTIVE
SERVICE TOOLS
DISPLAYS

Each **WILDE®** Roll Spring Punch has a pilot point that fits into the hollow center of the pin, holding the driving shoulder of the punch in perfect contact position. Pins are quickly and easily removed without damage to wall of hole or pin.

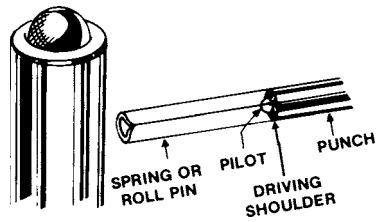

	Point Size	Pin Length	Overall Length	
RS232	1/16	1	2-3/4	10
RS564	5/64	1-1/2	3-1/4	10
RS332	3/32	1-1/2	3-1/2	10
RS432	1/8	2	4	10
RS532	5/32	2-1/2	4-1/2	10
RS632	3/16	2-1/2	4-1/2	10
RS732	7/32	3	5	10
RS832	1/4	3-1/2	5-1/2	10
RS1032	5/16	4	6	10
RS1232	3/8	4	6	10
RS1432	7/16	4	6	10
RS1632	1/2	4	6	10



RS906	6-Piece Roll Spring Punch Set in clear, zipper seal, hang-up vinyl pouch.	5	Set of 1 each: RS432 RS532 RS632 RS732 RS832 RS1032
-------	---	---	--

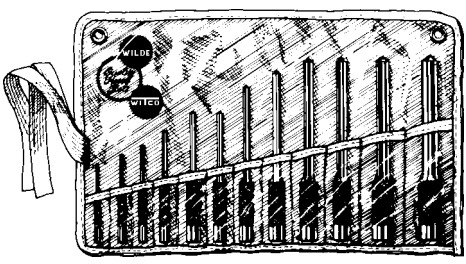

RS912	12-Piece Roll Spring Punch Set in a sturdy roll kit vinyl pouch.	5	Set of 1 each: RS232 RS564 RS332 RS432 RS532 RS632 RS732 RS832 RS1032 RS1232 RS1432 RS1632
-------	--	---	--

PLIERS
 PUNCHES, CHISELS & PRY BARS
 WRENCHES
 SCREWDRIVERS
 PLUMBING & INDUSTRIAL
 AUTOMOTIVE
 SERVICE TOOLS
 DISPLAYS



NOTES



WRENCHES

WILDE ADJUSTABLE WRENCHES

Drop-forged alloy steel. Properly heat treated with jaws accurately machined. Extra strong, extra thin jaws to get into tight places. All parts are subjected to the most modern scientific process of heat treating. Every handle uses a husky I-Beam construction and has a hole for hanging up the wrench. Wrenches are finished in either plated or industrial black finish. See Page 40.

S.A.E. & METRIC

WILDE COMBINATION WRENCHES

Quality combination wrenches, drop forged from alloy steel, precision heat treated, with polished heads and double plating of nickel and chrome. Box end for easy tightening of nuts, open end of the same size for fast turning. Box end is offset 15° to clear obstructions and the 15° open end needs only 30° of handle movement. All wrenches are 12 point. See Page 34. Sets Page 34.

RATCHETING BOX WRENCHES

Ideal when working in limited space. Sturdy and thin, they reach into extremely close places. They are open faced and reversible by merely turning the wrench over. The 5/8" by 3/4" is practically a must for installing and removing oil filters on late model Ford, Mercury, Lincoln, Oldsmobile, Dodge cars. High grade alloy steel. Plated. Sizes to and including 9/16" are six point, larger sizes are twelve point.

Standard, Metric and Refrigeration sizes available. See Pages 36 & 37. Sets Page 36 & 37.

WILDE IGNITION WRENCHES

Drop forged from special alloy steel. Thin, light weight but amazingly strong. Open end wrenches have a 15° angled head. Box end wrenches are 6 point with a 45° offset. See Page 35. Sets page 35.

SOCKET WRENCHES

A full line of 1/4", 3/8" and 1/2" SAE and METRIC sockets and accessories. Sets are furnished in either heavy duty molded storage cases or metal boxes. See Pages 28, 29, 30, 31, 32 & 33.

WILDE'S IMPROVED AIR CONDITIONING AND REFRIGERATION RATCHETS

For servicing automotive, commercial, and home air-conditioners, refrigerators and freezers. Heavy duty fully reversible. Wide size ranges. See Page 37.



A NEW ANGLE ON AN ESTABLISHED HAND TOOL

To be precise, it's a 25° offset angle on our line of Ratcheting Box Wrenches. These new wrenches allow you to reach those tight situations without scraping your knuckles and still provides you the speed and convenience of a Ratcheting Box Wrench.

In addition, you can reverse directions by simply flipping the reversing lever with your thumb or finger.

Anytime you need a wrench, the work goes faster with a Ratcheting Box Wrench. See Pages 38 & 39. Sets Page 38 & 39..

METRIC IGNITION WRENCHES

Open end wrenches which have 15° and 60° openings. All included in a 12-piece ignition set which includes gauge and spark testing screwdriver. See Page 35. Set Page 35.

SPARK TESTING SCREWDRIVER

5-1/4" Spark Testing Screwdriver. 1/8" x 2-1/2". Clear plastic handle with replaceable charge testing bulb. See Page 35.

PLIERS

PUNCHES, CHISELS & PRY BARS

WRENCHES

SCREWDRIVERS

PLUMBING & INDUSTRIAL

AUTOMOTIVE

SERVICE TOOLS

DISPLAYS



SOCKET SETS

Cat. No.	Description	St. Pk.	Sets Consists of 1 each:
----------	-------------	---------	--------------------------

PLIERS

PUNCHES, CHISELS & PRY BARS

WRENCHES

SCREWDRIVERS

PLUMBING & INDUSTRIAL

AUTOMOTIVE

SERVICE TOOLS

DISPLAYS

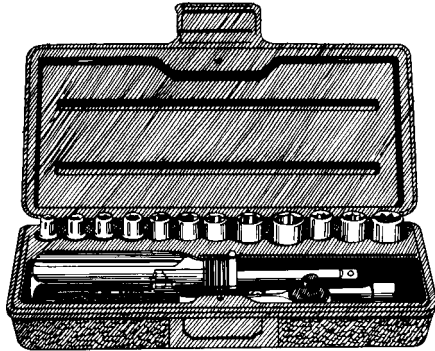

12000	15-Piece Socket Set. 1/4" Square Drive Standard. 9-6 Pt. Sockets: 3/16", 7/32", 1/4", 9/32", 5/16", 11/32", 3/8", 7/16", 1/2". 3-8 Pt. Sockets: 1/4", 5/16", 3/8". 1-Reversible Ratchet. 1-3" Extension. 1-Spinner Handle. In Molded Storage Case.	5	12103 12150 12180 12206 12207 12208 12209 12210 12211 12212 12214 12216 12908 12910 12912
-------	---	---	---

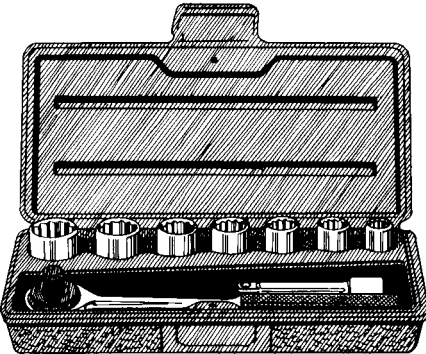

12001	9-Piece Socket Set. 3/8" Square Drive Standard. 7-12 Pt. Sockets: 3/8", 7/16", 1/2", 9/16", 5/8", 11/16", 3/4". 1-Reversible Ratchet. 1-3" Extension. In Metal Box.	5	13103 13150 13312 13314 13316 13318 13320 13322 13324
-------	--	---	---

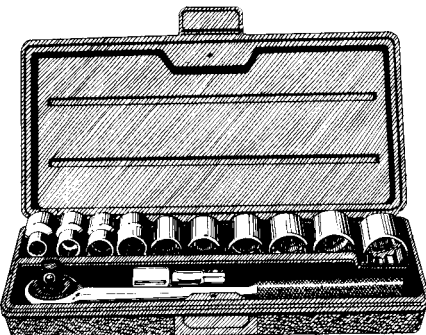

12003	12-Piece Socket Set. 1/2" Square Drive Standard. 10-12 Pt. Sockets: 3/8", 7/16", 1/2", 9/16", 5/8", 11/16", 3/4", 13/16", 7/8", 15/16". 1-Reversible Ratchet. 1- 2-1/2" Extension. In Molded Storage Case.	5	14102 14150 14312 14314 14316 14318 14320 14322 14324 14326 14328 14330
-------	--	---	--

SOCKET SETS

Cat. No. Description St. Pk. Sets Consists of 1 each:

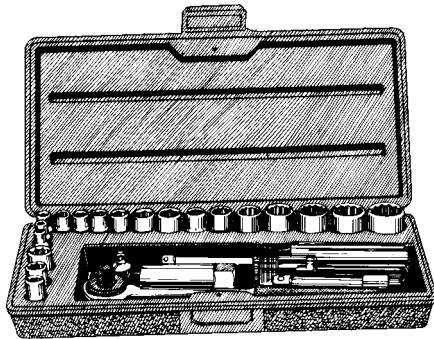

12004 24-Piece Standard Set. 5

1/4" & 3/8" Square Drive Standard.

1/4" = 9-6 Pt. Sockets:
 3/16", 7/32", 1/4",
 9/32", 5/16", 11/32",
 3/8", 7/16", 1/2".

3-8 Pt. Sockets:
 1/4", 5/16", 3/8".

1-Spinner Handle.

3/8" = 7-12 Pt. Sockets:
 3/8", 7/16", 1/2",
 9/16", 5/8", 11/16",
 3/4".

1-Reversible Ratchet.
 1-3" Extension.
 1-3/8"F to 1/4"M Adaptor.
 1-5/8" Spark Plug Socket.
 In Metal Box.

12180
 13103
 13150
 13181
 12206
 12207
 12208
 12209
 12210
 12211
 12212
 12214
 12216
 12908
 12910
 12912
 13312
 13314
 13316
 13318
 13320
 13322
 13324
 13620

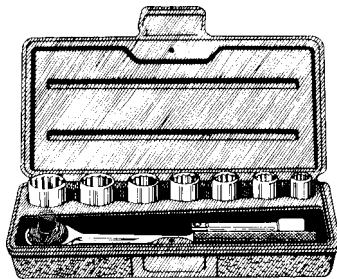

12002 9-Piece Socket Set. 5

3/8" Square Drive **Metric**.

7-12 Pt. Sockets:
 10mm, 12mm, 13mm,
 14mm, 15mm, 17mm,
 19mm.

1-Reversible Ratchet.
 1-3" Extension.
 In Metal Box.

13103
 13150
 53310
 53312
 53313
 53314
 53315
 53317
 53319

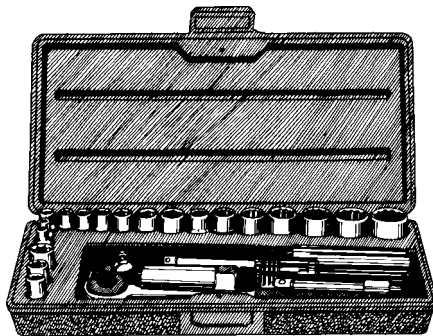

12005 24-Piece Socket Set. 5

1/4" & 3/8" Square Drive **Metric**.

1/4" = 9-6 Pt. Sockets:
 4mm, 4.5mm, 5mm,
 5.5mm, 6mm, 7mm,
 8mm, 9mm, 10mm.

3-8 Pt. Sockets:
 1/4", 5/16", 3/8".

1- Spinner Handle.

3/8" = 7-12 Pt. Sockets:
 10mm, 12mm, 13mm,
 14mm, 15mm, 17mm,
 19mm.

1-Reversible Ratchet.
 1-3" Extension.
 1-3/8"F to 1/4"M Adaptor.
 1-5/8" Spark Plug Socket.
 In Metal Box.

12180
 13103
 13150
 13181
 12908
 12910
 12912
 13620
 52204
 52245
 52205
 52255
 52206
 52207
 52208
 52209
 52210
 53310
 53312
 53313
 53314
 53315
 53317
 53319

PLIERS
 PUNCHES, CHISELS & PRY BARS
 WRENCHES
 SCREWDRIVERS
 PLUMBING & INDUSTRIAL
 AUTOMOTIVE
 SERVICE TOOLS
 DISPLAYS



SOCKETS 1/4" DRIVE

Cat. No.	Description	St. Pk.
12102	2" Extension	10
12103	3" Extension	10
12106	6" Extension	10
903121	3-Pc. Set of #'s 12102-12106	5



PLIERS



12150	5-1/2" Reversible Ratchet	10
-------	---------------------------	----

PUNCHES, CHISELS & PRY BARS



12606	5-1/2" Flex Handle	10
-------	--------------------	----

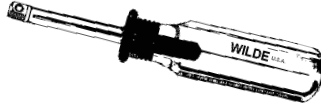

12180	Spinner Handle	5
-------	----------------	---

WRENCHES



12170	Universal Joint	10
-------	-----------------	----

Cat. No.	Size	St. Pk.	Cat. No.	Size	St. Pk.
----------	------	---------	----------	------	---------

6 POINT REGULAR SOCKETS



12206	3/16"	10	12211	11/32"	10
12207	7/32"	10	12212	3/8"	10
12208	1/4"	10	12214	7/16"	10
12209	9/32"	10	12216	1/2"	10
12210	5/16"	10			

909122	9-Piece Set of #'s 12206-12216	10
--------	--------------------------------	----

PLUMBING & INDUSTRIAL

6 POINT DEEP SOCKETS

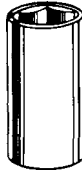

12406	3/16"	10	12411	11/32"	10
12407	7/32"	10	12412	3/8"	10
12408	1/4"	10	12414	7/16"	10
12409	9/32"	10	12416	1/2"	10
12410	5/16"	10			

909124	9-Piece Set of #'s 12406-12416	10
--------	--------------------------------	----

AUTOMOTIVE

6 POINT REGULAR SOCKETS - METRIC



52204	4mm	10	52207	7mm	10
52245	4.5mm	10	52208	8mm	10
52205	5mm	10	52209	9mm	10
52255	5.5mm	10	52210	10mm	10
52206	6mm	10			

909522	9-Piece Set of #'s 52204-52210	10
--------	--------------------------------	----

SERVICE TOOLS

8 POINT SOCKETS

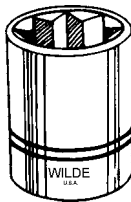



12908	1/4"	10
12910	5/16"	10
12912	3/8"	10

903129	3-Piece Set of #'s 12908-12912	10
--------	--------------------------------	----

DISPLAYS

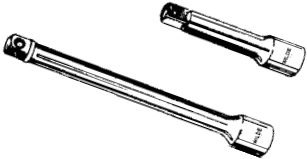
SOCKETS 3/8" DRIVE

	Cat. No.	Description	St. Pk.
	13103	3" Extension	10
	13104	5" Extension	10
	13106	6" Extension	10
	13107	10" Extension	10
	904131	4-Pc. Set of #'s 13103-13107	5

	13150	8" Reversible Ratchet	10
---	-------	-----------------------	----

	13160	8" Flex Handle	10
---	-------	----------------	----

	13170	Universal Joint	10
---	-------	-----------------	----

	13181	3/8"F x 1/4"M Adaptor	10
	13182	3/8"F x 1/2"M Adaptor	10
	902131	2-Pc. Set of #'s 13181-13182	5

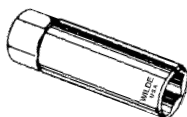
	13620	5/8" Spark Plug Socket	10
	13626	13/16" Spark Plug Socket	10
	902136	2-Pc. Set of #'s 13620-13626	5

Cat. No.	Size	St. Pk.	Cat. No.	Size	St. Pk.
----------	------	---------	----------	------	---------

6 POINT REGULAR SOCKETS

	13212	3/8"	10	13220	5/8"	10
	13214	7/16"	10	13222	11/16"	10
	13216	1/2"	10	13224	3/4"	10
	13218	9/16"	10	13226	13/16"	10
	908132	8-Piece Set of #'s 13212-13226				5

12 POINT REGULAR SOCKETS

	13312	3/8"	10	13322	11/16"	10
	13314	7/16"	10	13324	3/4"	10
	13316	1/2"	10	13326	13/16"	10
	13318	9/16"	10	13328	7/8"	10
	13320	5/8"	10			
	911133	9-Piece Set of #'s 13312-13328				5

3/8" Drive continued next page



PLIERS

PUNCHES, CHISELS & PRY BARS

WRENCHES

SCREWDRIVERS

PLUMBING & INDUSTRIAL

AUTOMOTIVE

SERVICE TOOLS

DISPLAYS

SOCKETS 3/8" DRIVE

Cat. No.	Size	St. Pk.	Cat. No.	Size	St. Pk.
----------	------	---------	----------	------	---------



12 POINT FLEX SOCKETS

TO BE DISCONTINUED
WHEN STOCK
DEPLETED

13312X	3/8"	10	13320X	5/8"	10
13314X	7/16"	10	13322X	11/16"	10
13316X	1/2"	10	13324X	3/4"	10
13318X	9/16"	10			
907133X	7-Piece Set of #'s 13312X-13324X				5



6 POINT DEEP SOCKETS

13412	3/8"	10	13422	11/16"	10
13414	7/16"	10	13424	3/4"	10
13416	1/2"	10	13426	13/16"	10
13418	9/16"	10	13428	7/8"	10
13420	5/8"	10			
909134	9-Piece Set of #'s 13412-13428				5



12 POINT DEEP SOCKETS

13512	3/8"	10	13522	11/16"	10
13514	7/16"	10	13524	3/4"	10
13516	1/2"	10	13526	13/16"	10
13518	9/16"	10	13528	7/8"	10
13520	5/8"	10			
909135	9-Piece Set of #'s 13512-13528				5



6 POINT REGULAR SOCKETS - METRIC

53207	7mm	10	53214	14 mm	10
53208	8mm	10	53215	15 mm	10
53209	9mm	10	53216	16 mm	10
53210	10 mm	10	53217	17 mm	10
53211	11 mm	10	53218	18 mm	10
53212	12 mm	10	53219	19 mm	10
53213	13 mm	10			
913532	13-Piece Set of #'s 53207-53219				



12 POINT REGULAR SOCKETS - METRIC

53307	7mm	10	53314	14 mm	10
53308	8mm	10	53315	15 mm	10
53309	9mm	10	53316	16 mm	10
53310	10 mm	10	53317	17 mm	10
53311	11 mm	10	53318	18 mm	10
53312	12 mm	10	53319	19 mm	10
53313	13 mm	10			
913533	13-Piece Set of #'s 53307-53319				5

PLIERS

PUNCHES, CHISELS
& PRY BARS

WRENCHES

SCREWDRIVERS





PLUMBING &
INDUSTRIAL

AUTOMOTIVE

SERVICE TOOLS

DISPLAYS

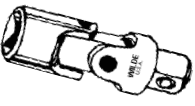
SOCKETS 1/2" DRIVE

	Cat. No.	Description	St. Pk.			
	14102	2-1/2" Extension	10			
	14105	5" Extension	10			
	14110	10" Extension	5			
	903141	3-Pc. Set of #'s 14102-14110	5			
<hr/>						
	14150	10" Reversible Ratchet	5			
<hr/>						
	14160	10" Flex Handle	5			
	14161	17" Flex Handle	5			
	902141	2-Pc. Set of #'s 14160-14161	5			
<hr/>						
	14170	Universal Joint	10			
<hr/>						
	14181	1/2"F x 3/8"M Adaptor	10			
<hr/>						
	Cat. No.	Size	St. Pk.	Cat. No.	Size	St. Pk.

12 POINT REGULAR SOCKETS

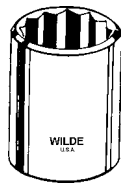

14312	3/8"	10	14328	7/8"	10
14314	7/16"	10	14330	15/16"	10
14316	1/2"	10	14332	1"	10
14318	9/16"	10	14334	1-1/16"	10
14320	5/8"	10	14336	1-1/8"	10
14322	11/16"	10	14338	1-3/16"	10
14324	3/4"	10	14340	1-1/4"	10
14326	13/16"	10			
915143	15-Piece Set of #'s 14312-14340				1

PLIERS

PUNCHES, CHISELS
& PRY BARS

WRENCHES

SCREWDRIVERS

PLUMBING &
INDUSTRIAL

AUTOMOTIVE

SERVICE TOOLS

DISPLAYS



**FRACTIONAL & METRIC
COMBINATION WRENCHES**

Cat. No.	Description	OAL	St. Pk.
189	3/8" Combination Wrench.	4-7/8"	20
190	7/16" Combination Wrench.	5-1/2"	20
191	1/2" Combination Wrench.	6"	10
192	9/16" Combination Wrench.	6-7/8"	10
193	5/8" Combination Wrench.	7-1/2"	10
194	11/16" Combination Wrench.	8-5/16"	10
195	3/4" Combination Wrench.	9-1/4"	10
196	13/16" Combination Wrench.	10-1/4"	10
197	7/8" Combination Wrench.	11-1/4"	10
198	15/16" Combination Wrench.	12-3/8"	10
199	1" Combination Wrench.	13-1/2"	10
201	1-1/16" Combination Wrench.	14-3/4"	5
202	1-1/8" Combination Wrench.	15-3/4"	5
203	1-1/4" Combination Wrench.	17-1/2"	5
MC10	10mm Combination Wrench.	4-3/8"	10
MC11	11mm Combination Wrench.	5-1/2"	10
MC12	12mm Combination Wrench.	5-3/4"	10
MC13	13mm Combination Wrench.	6"	10
MC14	14mm Combination Wrench.	6-7/8"	10
MC15	15mm Combination Wrench.	7-1/4"	10
MC16	16mm Combination Wrench.	7-1/2"	10
MC17	17mm Combination Wrench.	8-1/4"	10
MC18	18mm Combination Wrench.	9"	10
MC19	19mm Combination Wrench.	9-1/4"	10

- 12 POINT BOX ENDS
- PRECISION BROACHED
- CHAMFERED BOX ENDS
- FULL POLISHED SIDES & FACES OF OPEN ENDS
- PLATED FOR DURABILITY

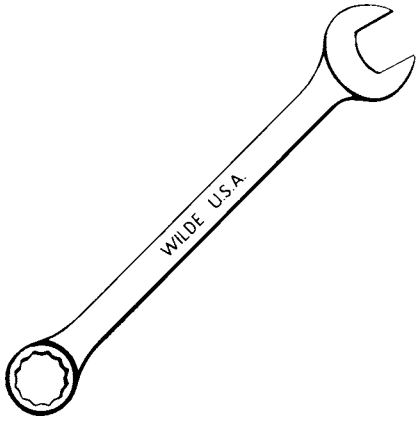

PLIERS
PUNCHES, CHISELS & PRY BARS
WRENCHES
SCREWDRIERS
PLUMBING & INDUSTRIAL
AUTOMOTIVE
SERVICE TOOLS
DISPLAYS

208	6-Pc. Fractional Combination Wrench Set. 1 ea. 190-195 in roll kit.	1
208B	#208 in a box instead of roll kit.	1

208
SMC6

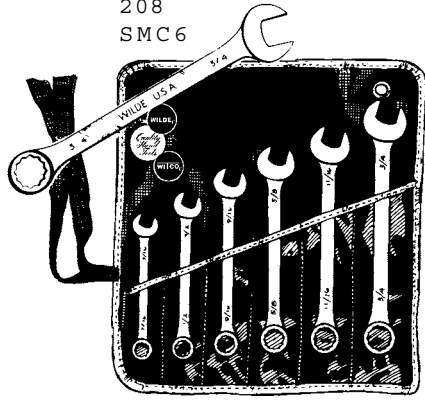

209	10-Pc. Fractional Combination Wrench Set. 1 ea. 189-195 & 197-199 in roll kit.	1
209B	#209 in a box instead of roll kit.	1

210	14-Pc. Fractional Combination Wrench Set. 1 ea. 189-203 in roll kit.	1
210B	#210 in a box instead of roll kit.	1

- 12 POINT BOX ENDS
- PRECISION BROACHED
- CHAMFERED BOX ENDS

SMC6	6-Pc. Metric Combination Wrench Set. 1 ea. MC10-MC15 in roll kit.	1
SMC6B	#SMC6 in a box instead of roll kit.	1

- FULL POLISHED SIDES & FACES OF OPEN ENDS
- PLATED FOR DURABILITY

SMC10	10-Pc. Metric Combination Wrench Set. 1 ea. MC10-MC19 in roll kit.	1
SMC10B	#SMC10 in a box instead of roll kit.	1

209
SMC10

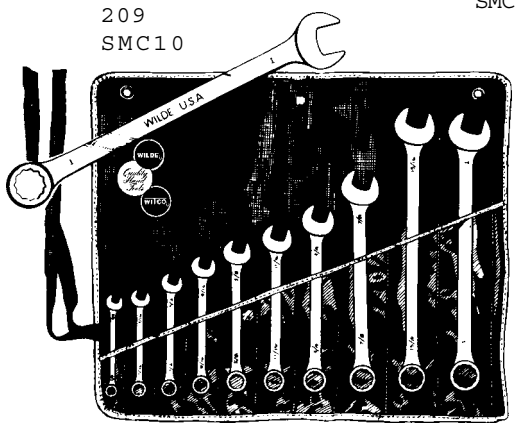

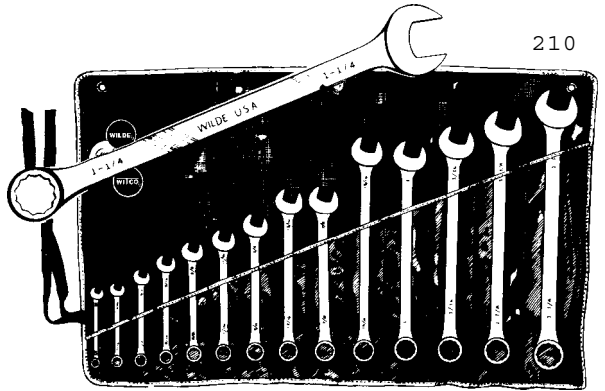

210



IGNITION WRENCHES

	Cat. No.	Box Sizes	Length	Std. Pk.
	204	3/16"x13/64"	2-13/16"	20
	205	7/32"x15/64"	3-3/32"	20
	206	1/4"x9/32"	3-3/8"	20
	205	5/16"x11/32"	3-3/4"	20

		Sizes	Length	Thickness	Std. Pk.
	1718	13/64"x7/32"	3"	7/64"	20
	1719	15/64"x1/4"	3-1/4"	7/64"	20
	1720	9/32"x11/32"	3-1/2"	1/8"	20
	1721	5/16"x3/8"	3-3/4"	9/64"	20

		Openings		Length	Head Thickness	Std. Pk.
		15°	60°			
	1722	6mm	5mm	3.00"	.125	20
	1723	7mm	8mm	3.315"	.156	20
	1724	8mm	7mm	3.315"	.156	20
	1725	10mm	9mm	3.565"	.156	20
	1726	9mm	10mm	3.565"	.156	20
	1727	11mm	12mm	4.128"	.188	20
	1728	12mm	11mm	4.128"	.188	20

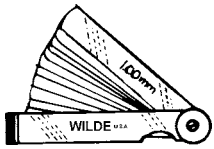

499 Metric Ignition Gauge. Contains thirteen 1/2" x 3" blades of the following thickness: .050, .100, .150, .200, .250, .300, .400, .500, .600, .700, .800, .900, 1.000mm's.



21900 5-1/4" Spark Testing Screw driver. 1/8" x 2-1/2". Clear plastic handle with replaceable charge testing bulb.

Cat. No.	Description	Std. Pk.
156R	4-pc Ignition Wrench Set. Contains one each 1718, 1719, 1720, 1721 in plastic kit.	5
158R	5-pc. Ignition Set. Contains one each 1718, 1719, 1720, 1721, 5S in plastic kit.	5
159R	4-pc. Min. Box Wrench Set. Contains one each 204, 205, 206, 207 in plastic kit.	5
160R	8-pc. Ignition Wrench Set. Contains one each 1718, 1719, 1720, 1721, 204, 205, 206, 207 in plastic kit.	5
164R	7-pc. Ignition Set. Contains one each 1718, 1719, 1720, 1721, 5S, 504, 770 in plastic kit.	5
8954	12-pc. Ignition Set. Contains one each 1722-1728, 5S, 499, 21900, 175, 770 in plastic kit.	1

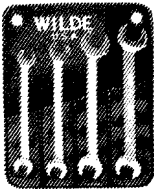

156R

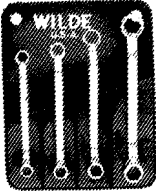

158R

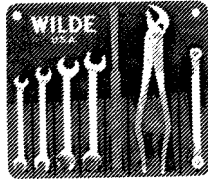

159R



160R

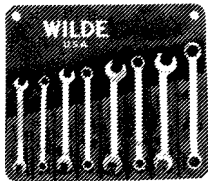

164R

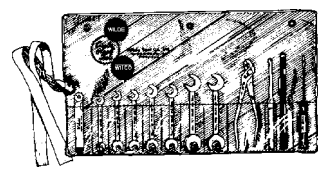

8954



PLIERS

PUNCHES, CHISELS & PRY BARS

WRENCHES

SCREWDRIVERS

PLUMBING & INDUSTRIAL

AUTOMOTIVE

SERVICE TOOLS

DISPLAYS

RATCHETING WRENCHES

Cat. No.

Description

Std. Pk.

RATCHET BOX WRENCH

- PLIERS
- PUNCHES, CHISELS & PRY BARS
- WRENCHES
- SCREWDRIERS
- PLUMBING & INDUSTRIAL
- AUTOMOTIVE
- SERVICE TOOLS
- DISPLAYS

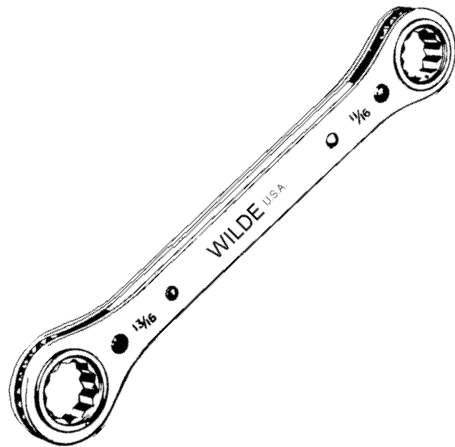

Box Sizes Point Length Thickness

873	1/4" x 5/16"	6	4-1/8"	3/8"	6
874	3/8" x 7/16"	6	5-1/2"	3/8"	6
875B	1/2" x 7/16"	6	6-3/4"	1/2"	6
875	1/2" x 9/16"	6	6-3/4"	1/2"	6
876	5/8" x 11/16"	12	8"	1/2"	6
877	5/8" x 3/4"	12	8"	1/2"	6
878	11/16" x 13/16"	12	9-1/4"	1/2"	6
879	3/4" x 7/8"	12	9-1/4"	1/2"	6
880	13/16" x 15/16"	12	9-1/4"	1/2"	6

NOTE:
#873 IS NOT FOR USE ON
BATTERY TERMINAL NUTS.
SEE #871 PAGES 37.

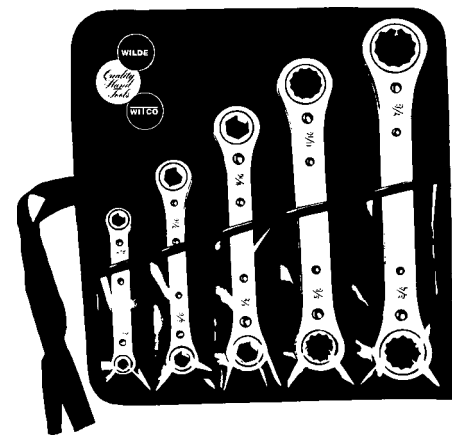

883	3-Pc. Ratchet Box Wrench Set. Contains one each 874, 875 and 876 in a handy plastic kit.	5
885	5-Pc. Ratchet Box Wrench Set. Contains one each 873, 874, 875, 876 and 879 in a handy plastic kit.	5

RATCHETING WRENCHES

Cat. No.	Description	Std. Pk.
----------	-------------	----------

METRIC RATCHET BOX WRENCH

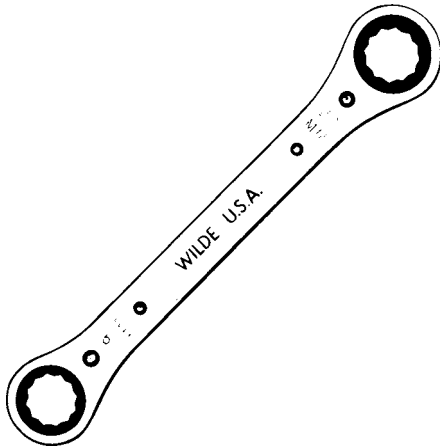

Cat. No.	Box Sizes	Point	Length	Std. Pk.
862	7mm x 8mm	6	4-1/4"	6
863	9mm x 10mm	6	5-1/2"	6
864	11mm x 12mm	6	6-7/8"	6
865	13mm x 14mm	6	6-7/8"	6
866	15mm x 17mm	12	8"	6
867	16mm x 18mm	12	8"	6
868	19mm x 21mm	12	9-1/4"	6

PLIERS
PUNCHES, CHISELS & PRY BARS
WRENCHES

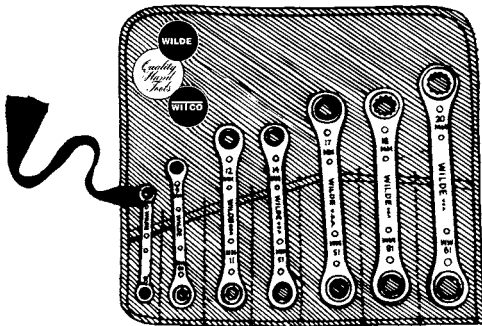

870	7-Pc. Metric Ratchet Box Wrench Set. Contains one each 862, 863, 864, 865, 866, 867 and 868 in a plastic kit.	5
-----	--	---

SCREWDRIVERS
PLUMBING & INDUSTRIAL

Air Conditioning & Refrigeration RATCHETS

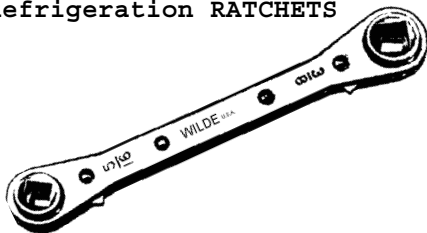

900	3/8" x 5/16" Square 1/4" x 3/16" Square	6
990	1/4" x 3/16" Square 9/16 x 1/2" Hex	6

AUTOMOTIVE
SERVICE TOOLS

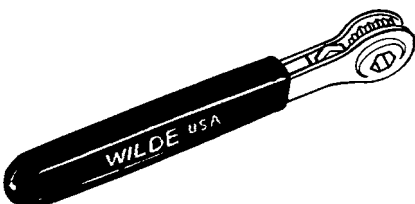

871	5/16" Reversible Side Terminal Battery Wrench. Insulated vinyl handle prevents electrical shock. Heat-treated and nickel-chrome plated.	6
-----	---	---



DISPLAYS



RATCHET BOX WRENCH

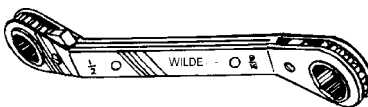
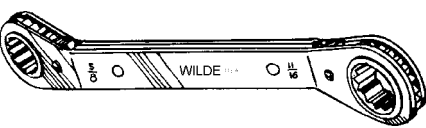
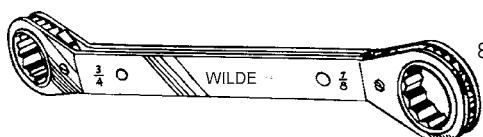

- PLIERS
- PUNCHES, CHISELS & PRY BARS
- WRENCHES
- SCREWDRIVERS
- PLUMBING & INDUSTRIAL
- AUTOMOTIVE
- SERVICE TOOLS
- DISPLAYS

		Box Sizes	Point	Length	
	800	1/4" x 5/16"	12	4-3/32"	6
	801	3/8" x 7/16"	12	5-7/32"	6
	802	1/2" x 9/16"	12	6-15/32"	6
	803	5/8" x 11/16"	12	7-21/32"	6
	804	3/4" x 7/8"	12	8-3/4"	6

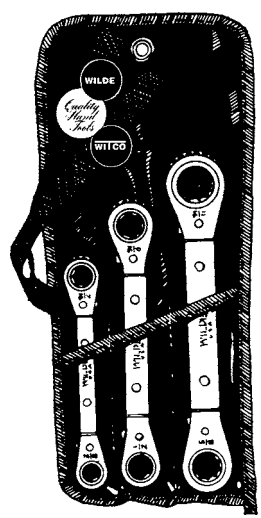

805 3-Pc. OFF/SET Ratchet Box Wrench Set. Contains one each 801, 802 and 803 in a handy plastic kit. 5



806 5-Pc. OFF/SET Ratchet Box Wrench Set. Contains one each 800, 801, 802, 803 and 804 in a handy plastic kit. 5

METRIC RATCHET BOX WRENCH



Box Sizes Point Length



810 7mm x 8mm 6 4-3/32" 6



811 9mm x 10mm 6 5-7/32" 6

812 11mm x 12mm 6 6-15/32" 6

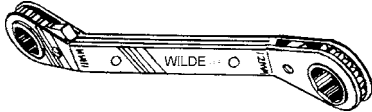

813 13mm x 14mm 6 6-15/32" 6

814 15mm x 17mm 12 7-27/32" 6

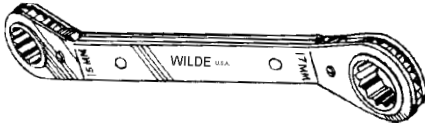

815 16mm x 18mm 12 7-27/32" 6

816 19mm x 21mm 12 8-3/4" 6

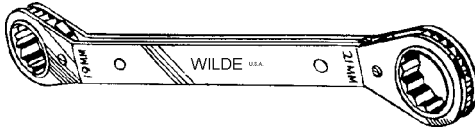

PLIERS
PUNCHES, CHISELS & PRY BARS
WRENCHES
SCREWDRIVERS
PLUMBING & INDUSTRIAL
AUTOMOTIVE
SERVICE TOOLS
DISPLAYS

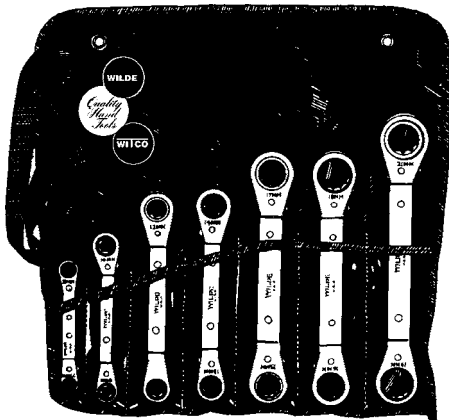

817 7-Pc. OFF/SET Ratchet Box Wrench Set. Contains one each 810, 811, 812, 813, 814, 815 and 816 in a handy plastic kit. 5



PLATED

Length Jaw Capacity

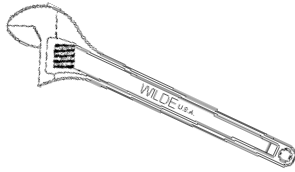

AWC 4 4" 1/2" 5

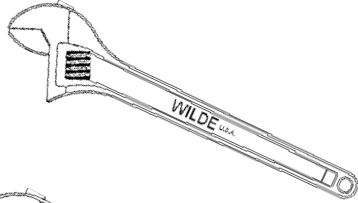

AWC 6 6" 15/16" 5

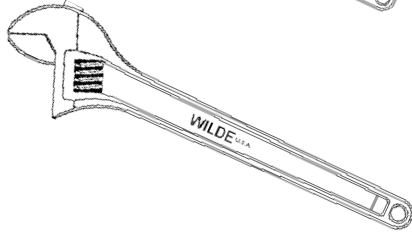

AWC 8 8" 1-1/8" 5

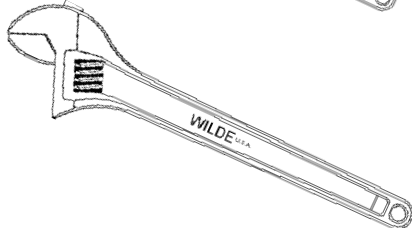

AWC 10 10" 1-9/32" 5

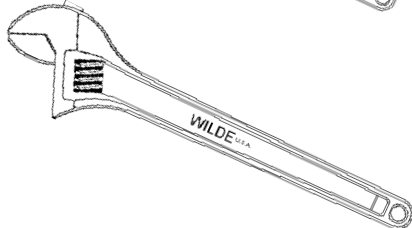

AWC 12 12" 1-1/2" 5

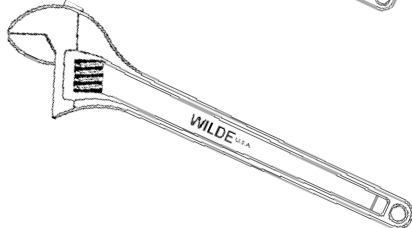

AWC 15 15" 1-3/4" 5

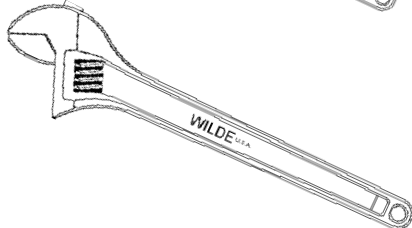

AWC 18 18" 2-1/8" 1

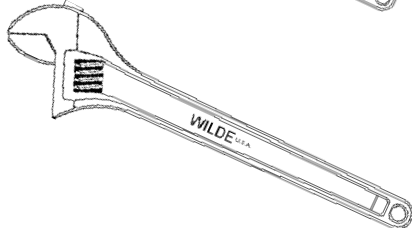

AWC 24 24" 2-1/2" 1

- Forged Alloy Steel
- Heat Treated for Strength
- Spring Tension Knurl for smoother operation
- Precision Pin prevents loosening of lower jaw
- Rounded Edges for comfort and better grip
- Tapered Head & Flat Nose for access into tight places

INDUSTRIAL BLACK

AWB 4 4" 1/2" 5



AWB 6 6" 15/16" 5



AWB 8 8" 1-1/8" 5



AWB 10 10" 1-9/32" 5



AWB 12 12" 1-1/2" 5



AWB 15 15" 1-3/4" 5



AWB 18 18" 2-1/8" 1



AWB 24 24" 2-1/2" 1

- PLIERS
- PUNCHES, CHISELS & PRY BARS
- WRENCHES
- SCREWDRIVERS
- PLUMBING & INDUSTRIAL
- AUTOMOTIVE
- SERVICE TOOLS
- DISPLAYS



SCREWDRIVERS

WILDE "INSULITE" SQUARE SHANK SCREWDRIVERS

Handles are turned of extruded, clear white, acetate plastic rod, ferrule dipped red. They are non-inflammable; shockproof, breakproof and impervious to grease. Comfortable fluted design, extra large diameter and length give you a handful of screwdriver for a high power non-slip grip. Will not roll when laid down. Bits, of alloy steel, are heat treated for maximum hardness, toughness and wear. They are forged with extra long tapers to hold in screw slots under pressure without backing out. Bits are satin finish and plated.
See Page 42.

WILDE PHILLIPS ROUND SHANK SCREWDRIVERS SUPER HARD BITS

The general use of case hardened self tapping screws requires a Phillips bit that will fit accurately and stand up and give real service on these screws. Bits on these Screwdrivers are made of super hard alloy steel and accurately milled to size. Plated. Handles are "Insulite" fluted plastic non-flammable and wear resistant. They are of ample size for maximum comfort and turning power.
See Page 42.

4 IN 1 SCREWDRIVER MINIATURE and STANDARD SIZE

Quick Change Screwdriver. Has two slotted ends and two Phillips ends. Comfortable fluted handle. Alloy steel.
PLUS TORX ® bits.
See Page 43.

NEW WOODEN HANDLE SCREWDRIVERS

Back by popular demand. All the popular slotted and phillips sizes.
See Page 43.

STANDARD AND METRIC NUT DRIVERS

Sockets are machined from top grade tool steel, heat treated for extra hardness. All hollow shafts from the socket to the handle accommodate the longest stud. Shafts are machined from chrome vanadium steel, precision tempered and plated finished.
See Page 44.

TORX ® SCREWDRIVERS

General Motors, Ford and other major automotive manufacturers are now using TORX ® drive fasteners in seat belt and door striker bolts, door latches, deck lids, headlight bezels, carburetors, ignition systems and other applications.

Wilde Tool offers a complete line of TORX ® drivers for this new market.
See Page 45.

SLOTTED AND PHILLIPS SCREW STARTERS

This tool holds screws with a grip that will withstand an eight pound pull and automatically releases when pressure becomes too great. Lightweight Aluminum handles, tough high carbon steel gripping bits. This tool is made for starting screws only, use standard driver to tighten. Also available with magnet end and pencil clip.
See Page 45.

SCREWDRIVER SETS

Four of the most popular sets used. Three plastic handle sets and one **NEW WOODEN HANDLE** set.
See Page 43.



PLIERS

PUNCHES, CHISELS
& PRY BARS

WRENCHES

SCREWDRIVERS

PLUMBING &
INDUSTRIAL

AUTOMOTIVE

SERVICE TOOLS

DISPLAYS



SCREWDRIVERS

Cat. No. Description

Std. Pk.

SLOTTED: SQUARE SHANK

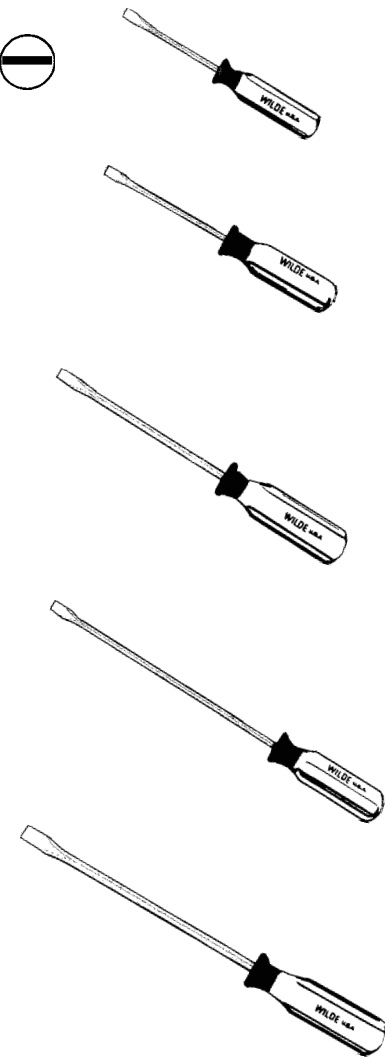

	Exposed Length	Handle Size	Overall Length		
S14	1/4" x 1-1/4"	1-3/16" x 2"	3-1/4"	10	Stubby
S22	1/8" x 2"	5/8" x 2-1/2"	4-1/2"	10	
S25	5/16" x 1-3/4"	1-1/4" x 4-1/2"	6-1/4"	10	
S42	1/8" x 4"	3/4" x 2-1/2"	6-1/2"	10	
S43	3/16" x 3-1/2"	1-1/16" x 3-3/4"	7-1/4"	10	
S44	1/4" x 4"	1-3/16" x 4-1/4"	8-1/4"	10	
S46	3/8" x 5"	1-5/16" x 4-3/4"	9-3/4"	10	
S64	1/4" x 6"	1-3/16" x 4-1/4"	10-1/4"	10	
S83	3/16" x 8"	1-1/16" x 3-3/4"	11-3/4"	10	
S85	5/16" x 7-1/2"	1-1/4" x 4-1/2"	12"	10	
S86	3/8" x 9"	1-5/16" x 4-3/4"	13-3/4"	10	
S104	1/4" x 12"	1-3/16" x 4-1/4"	16-1/4"	5	
S126	3/8" x 12"	1-5/16" x 4-3/4"	16-3/4"	5	

PHILLIPS: ROUND SHANK

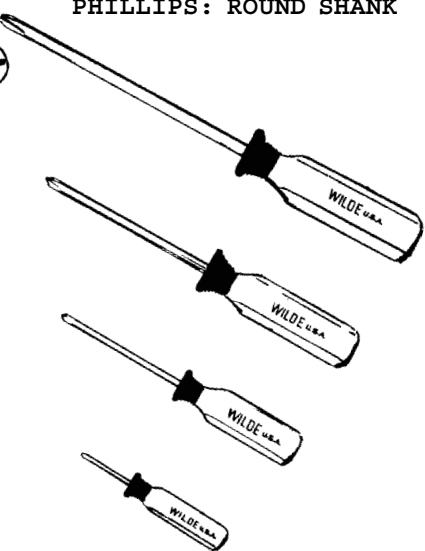

	Exposed Length	Point No.	Handle Size	Overall Length	Screw Size		
P142	1/4" x 1-1/2"	2	1-3/16"x2"	3-1/2"	5-10	10	Stubby
P220	1/8" x 2-1/2"	0	5/8"x2-1/2"	5"	2 & >2	10	
P331	3/16" x 3"	1	7/8" x 3"	6"	2-5	10	
P442	1/4" x 4"	2	1-1-16"x3-3/4"	7-3/4"	5-10	10	
P653	5/16" x 6-1/4"	3	1-3/16"x4-1/4"	10-1/2"	10-16	10	

PLIERS
PUNCHES, CHISELS & PRY BARS
WRENCHES
SCREWDRIVERS
PLUMBING & INDUSTRIAL
AUTOMOTIVE
SERVICE TOOLS
DISPLAYS

SCREWDRIVER SETS

Cat. No. Description Std. Pk.

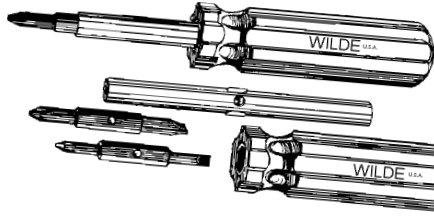

SW2 **MINIATURE** 4 in 1 Quick Change Screwdriver. Contains 1/8" and 3/16" Slotted; #0 and #1 Phillips. Alloy Steel. Overall Length 5-1/4".

SW2-1S Bit Only for SW2. 1/8" and 3/16". 10
 SW2-2L Bit Only for SW2. #0 and #1. 10

SW4 4 in 1 Quick Change Screwdriver. Bits reverse. Contains 3/16" and 5/16" Slotted; #1 and #2 Phillips. Alloy Steel. Overall Length 7-1/2".

SW4-1S Bit only for SW4. 3/16" and 5/16". 10
 SW4-2L Bit only for SW4. #1 and #2. 10
 SW4-T15 Bit only. Torx ® T15 and T20. 10
 SW4-T25 Bit only. Torx ® T25 and T30. 10
 SW4-R Bit only. Robinson. Reversible. 10

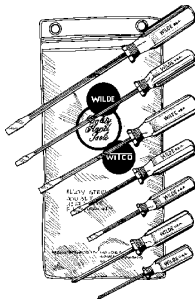

SW8 7-Pc. Plastic Handle Screwdriver Set. 5 Flat Blades & 2 Phillips. Contains one each **S43, S44, S64, S83, S85, P331** and **P442**. Packed in clear, sturdy hang-up vinyl pouch.

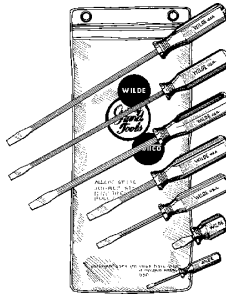

SW9 7-Pc. Plastic Handle Screwdriver Set. Contains one each **S14, S22, S44, S46, S64, S85,** and **S86**. Packed in clear, sturdy hang-up vinyl pouch.

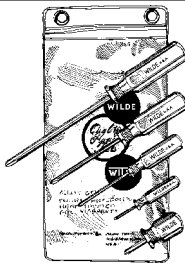

SW10 5-Pc. Plastic Handle Phillips Screwdriver Set. Contains one each **P142, P220, P331, P442** and **P653**. Packed in clear, sturdy hang-up vinyl pouch.

NEW



SW7 7-Pc. Wooden Handle Screwdriver Set. Packed in clear, sturdy hang-up vinyl pouch as follows.

SW7-1 3/16" x 2-1/2" #1 Phillips 10
 SW7-2 1/4" x 3" #2 Phillips 10
 SW7-3 1/8" x 3" Slotted 10
 SW7-4 3/16" x 2-1/2" Slotted 10
 SW7-5 3/16" x 5" Slotted 10
 SW7-6 1/4" x 6" Slotted 10
 SW7-7 5/16" x 7-1/2" Slotted 5

PLIERS
 PUNCHES, CHISELS & PRY BARS
 WRENCHES
 SCREWDRIVERS
 PLUMBING & INDUSTRIAL
 AUTOMOTIVE
 SERVICE TOOLS
 DISPLAYS



FRACTIONAL & METRIC NUT DRIVERS

Cat. No. Description

Std. Pk.

HEX FRACTIONAL NUT DRIVERS

- PLIERS
- PUNCHES, CHISELS & PRY BARS
- WRENCHES
- SCREWDRIVERS
- PLUMBING & INDUSTRIAL
- AUTOMOTIVE
- SERVICE TOOLS
- DISPLAYS

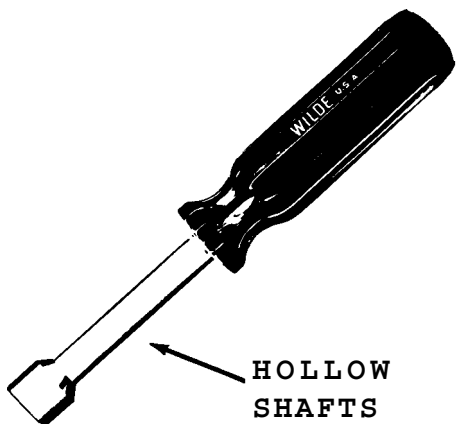

Size	Overall Length	Handle Color	
3/16"	6-5/8"	Black	10
1/4"	6-5/8"	Red	10
5/16"	6-5/8"	Amber	10
11/32"	6-5/8"	Green	10
3/8"	6-5/8"	Blue	10
7/16"	7"	Brown	10
1/2"	7"	Red	10

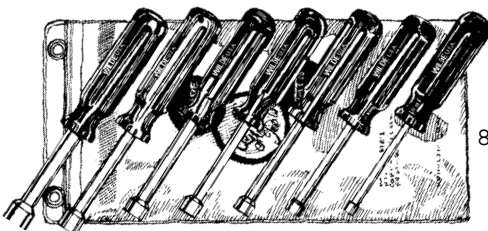

88 7-Pc. Nut Driver Set. Contains one each 81-87 in a vinyl pouch. 10

HEX METRIC NUT DRIVERS



MD 4	4 mm	6-5/8"	Black	10
MD4 5	4.5 mm	6-5/8"	Black	10
MD 5	5 mm	6-5/8"	Black	10
MD5 5	5.5 mm	6-5/8"	Black	10
MD 6	6 mm	6-5/8"	Black	10
MD 7	7 mm	6-5/8"	Black	10
MD 8	8 mm	6-5/8"	Black	10
MD 9	9 mm	6-5/8"	Black	10
MD1 0	10 mm	7"	Black	10
MD1 1	11 mm	7"	Black	10

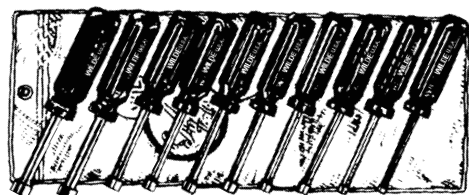

SMD910 10-Pc. Metric Hex Nut Driver Set. Contains one each MD4-MD11 in a vinyl pouch. 5

SCREW STARTERS & TORX® DRIVERS	Cat. No.	Description	Std. Pk.
--------------------------------	----------	-------------	----------

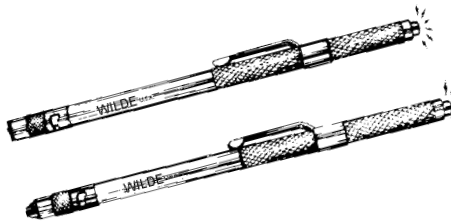
	175	5-5/8" Slotted Screw Starter. Aluminum knurled handle. Magnet end. Alloy steel screw starter bit. Pencil clip.	5
	175A	5-3/4" Phillips Screw Starter. Aluminum knurled handle. Magnet end. Alloy steel screw starter bit. Pencil clip.	5

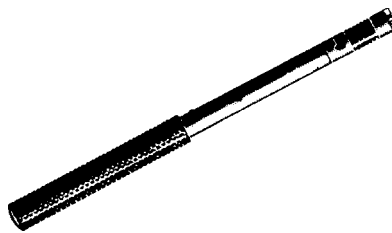
	656	2-1/2" Screw Starter. Aluminum. Withstands 8 lb. pull. Auto release. Duralumin handles, steel gripping bits. 1/4" Nib.	5
	657	5-1/2" Screw Starter. Aluminum. Withstands 8 lb. pull. Auto release. Duralumin handles, steel gripping bits. 1/4" Nib.	5
	658	9-1/2" Screw Starter. Aluminum. Withstands 8 lb. pull. Auto release. Duralumin handles, steel gripping bits. 1/4" Nib.	5

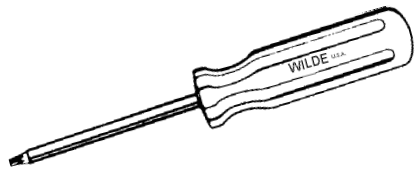
	T10	Torx Driver Size TX10	5
	T15	Torx Driver Size TX15	5
	T20	Torx Driver Size TX20	5
	T25	Torx Driver Size TX25	5
	T27	Torx Driver Size TX27	5
	T30	Torx Driver Size TX30	5
	TS35	6-Pc. Torx Driver Set. Contains one each T10-T30 in a sturdy vinyl pouch.	5

® Registered Trademark of Camcar Div. of Textron, Inc.



PLIERS

PUNCHES, CHISELS & PRY BARS

WRENCHES

SCREWDRIVERS

PLUMBING & INDUSTRIAL

AUTOMOTIVE

SERVICE TOOLS

DISPLAYS

SAFETY RULES FOR HAND TOOLS

- Always use the right size and type of tool for the job being done. Keep tools in proper working condition. Never alter a tool from its original condition.
- Protect your eyes. Always wear safety goggles when using tools; particularly when using punches, chisels, hammers, power tool attachments and cutting tools.
- Ordinary plastic dipped handles are designed for comfort —not electrical insulation.
- Never use a tool as a hammer unless manufactured for that purpose.
- When possible, always pull on a wrench handle rather than push and adjust your stance to prevent a fall.
- Never use a pipe extension or other form of "cheater" to increase the leverage of any wrench. Never use a hammer on any wrench, other than a striking face wrench that is designed to be struck.
- Adjustable wrenches should be tightly adjusted to the nut and pulled so that the force is on the side of the fixed jaw.
- Select a wrench whose opening exactly fits the nut. Always seat the wrench straight on the nut—do not cock the tool when turning.
- Ratchet mechanisms should be cleaned and lubricated periodically with light grade oil.
- Pliers should not be used for cutting hardened wire unless manufactured for that purpose. Always cut at right angles— don't rock from side to side when cutting.
- Always strike squarely with the hammer striking face parallel to the surface being struck. Avoid glancing blows and over and under strikes. Never strike an object with the side of a hammer. Do not strike one hammer with another hammer.
- Metal cutting chisels are intended for cutting, shaping and removing metal softer than the cutting edge itself. Never use these tools for cutting or splitting stone or concrete.
- Always strike the struck base of a chisel or punch squarely. The striking face of the hammer should have a diameter approximately 3/8" larger than the struck face of the punch or chisel.
- Never use a chisel or punch with a dull, chipped deformed cutting edge or point or mushroomed struck face.
- Use the right type of screwdriver with the right tip for the screw. Make sure the tip fits the screw slot, not too loose and not too tight.
- Never use screwdrivers with rounded edges or tips.
- Never use a screwdriver as a chisel, punch, scraper or pry bar. Use screwdrivers for screw driving only.
- Do not heat jaws of pullers when heating bearings or gears, as heating can change their temper. Do not use pullers with worn or damaged parts.
- Puller forcing screws should be kept clean and lubricated with medium grade oil. Puller should not be cocked at an angle when in use.
- When using slide hammer pullers, be sure hands are well away from hammer on the back end of the slide rod.
- Wilde Tool Co. cannot be responsible for injury or damage caused by tools improperly used, or from tools which have been abused or badly worn.

FEDERAL DESCRIPTIONS

The Federal descriptions shown in this catalog are intended as a guide only for classification of types of tools and do not mean that, in every case, the tool is in full compliance with the Federal Specification indicated. When bidding on tools that require conformity to Federal Specifications contact our Government Contract Department at Wilde Tool Co. in Hiawatha, Kansas.



PLUMBING & INDUSTRIAL TOOLS

TAPE MEASURES

Wilde introduces our line of Tape Measures. 16' x 3/4" blade and 25' x 1" blade. Plus we have a 100' long Steel Tape which has long Extension handle for quicker wind-up. And a 6' Wood Extension Rule. Has graduated brass extension.
See Page 48.

PIPE WRENCHES

The six popular pipe wrench sizes, jaw capacities from 1" to 5". I-beam cast iron handles. Heat-treated alloy steel jaws.
See Page 49.

FLARING TOOLS

Makes S.A.E. 45° flare joints in copper, brass or aluminum tubing. Self-centering yolk with quick-opening bar and large wing nuts. By adding our 400-AD to our 400-45, you can produce double-lap flares in all sizes except 5/8" tubing.
See Page 50.

TUBING CUTTERS

Micrometer action tubing cutters with alloy cutter wheel. Capacity 1/8" to 1-1/8" O.D. Cuts hard or soft copper, aluminum tubing and thin-wall conduit. Enclosed feed mechanism protects threads. Reamer blade locks in open or closed position.
See Page 50.

AVIATION & METAL CUTTING SNIPS

Three Aviation Snips cut right, left and straight. Heat treated alloy steel cuts 18 gauge cold rolled sheet metal. Serrated jaws. All snips have long lasting keen cutting edge.
See Page 55.



BRASS HAMMERS

Non-Marring. Non-Sparking.
See Pages 53.

HACK SAWS

All metal frame with comfortable pistol grip handle. Blades can be indexed to four positions. Adjustable for 8, 10 & 12 inch blades. Frame does not fall apart when blade is removed. (10" blade included).
See Page 51.

EXTRACTORS

Designed with a gradual taper and long flutes machined close to the cutting edges to permit the tightest grip. Forged from alloy steel. Industrial black finish. Meets Government Spec. No. GGG-E-936C.
See Page 53.

WILDE HANDLE PULLER

To remove handle, turn long threaded stem up until tip clears handle. Place arms under handle and bring sliding washer down until snug. Turn threaded stem down into screw hole until handle is free.
See Page 52.



Remove larger handles with longer adjustable puller arms.
See Page 52.



Fold-Up Hex Key Wrench Set 9 Pieces.
See Page 52.

Ball Tip L- Shape Hex Key Wrenches.
See Page 52.

T-Handle Hex Key Wrenches.
See Page 52.

Standard L-Shape Hex Key Wrenches.
See Page 52.

HAMMERS & SLEDGES

Taper design eliminates possibility of handle coming off. Handle is made from strong hickory wood. Head is heat treated for toughness. "Rim-Tempered" face reduces chipping. New forged and heat treated sledge hammers. In 16" and 36". Available in double face and cross pein styles.
See Pages 57 & 58.

PLIERS

PUNCHES, CHISELS & PRY BARS

WRENCHES

SCREWDRIVERS

PLUMBING & INDUSTRIAL

AUTOMOTIVE

SERVICE TOOLS

DISPLAYS



PLIERS
 PUNCHES, CHISELS & PRY BARS
 WRENCHES
 SCREWDRIERS
 PLUMBING & INDUSTRIAL
 AUTOMOTIVE
 SERVICE TOOLS
 DISPLAYS

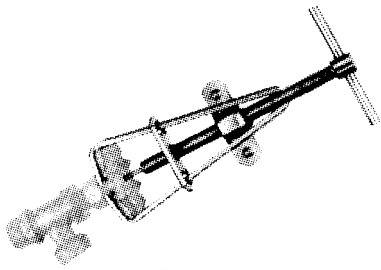

33P Faucet Handle Puller

5

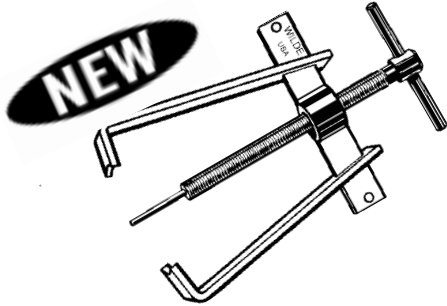

3870 Faucet Handle Puller.
 Removes larger handles with longer adjustable puller arms. One piece cast cross bar for strength and durability. Puller features notches that ensure positive and equal positioning of puller arms on cross bar. Alloy steel components.

5

Note:
 See other Pullers on Page 62.

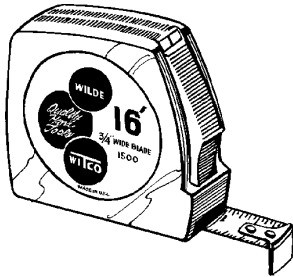

1500 16' Locking Tape.
 3/4" wide yellow blade. Graduated in sixteenths. 16" stud center marks. Baked on blade coating. 3 rivet end hook. Positive Lock. Oversized numbers. Direct reading inside measurement. Unbreakable chrome plated case.

6

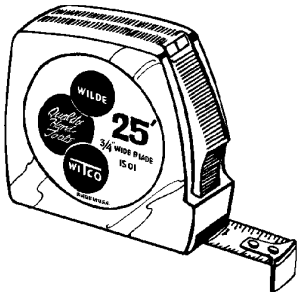

1501 25' Locking Tape.
 1" wide yellow blade. Graduated in sixteenths. 16" stud center marks. Baked on blade coating. 3 rivet end hook. Positive Lock. Oversized numbers. Direct reading inside measurement. Unbreakable chrome plated case.

6

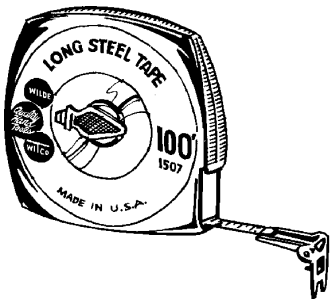

1507 100' Long Steel Tape.
 3/8" wide yellow tape. Graduated in eighths. Pop-open folding handle has longer extension for faster rewinding. Chrome plated case.

6

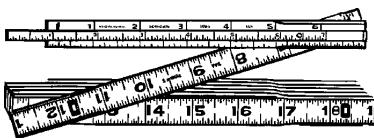

1510 6' Wood Extension Ruler.
 Outside reading. 6" graduated brass extension. 16" stud center marks. Boxwood finish.

6

PIPE WRENCHES



Cat. No.	Description	Std. Pk.
PW8	8" Heavy Duty Pipe Wrench. Jaw capacity 1". I-beam cast iron handle. Heat-treated alloy steel jaw.	6
PW10	10" Heavy Duty Pipe Wrench. Jaw capacity 1-1/2". I-beam cast iron handle. Heat-treated alloy steel jaw.	6
PW14	14" Heavy Duty Pipe Wrench. Jaw capacity 2". I-beam cast iron handle. Heat-treated alloy steel jaw.	6
PW18	18" Heavy Duty Pipe Wrench. Jaw capacity 2-1/2". I-beam cast iron handle. Heat-treated alloy steel jaw.	6
PW24	24" Heavy Duty Pipe Wrench. Jaw capacity 3". I-beam cast iron handle. Heat-treated alloy steel jaw.	6
PW36	36" Heavy Duty Pipe Wrench. Jaw capacity 5". I-beam cast iron handle. Heat-treated alloy steel jaw.	1

NOTE:  PIPE WRENCH PLIER® — PAGE 5 & 13

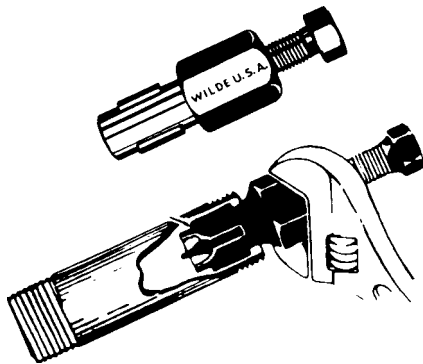

380	1/2" Internal Pipe Wrench. Expansion Blade. Loosens or tightens nipples, pipes & fittings.	5
383	3/4" Internal Pipe Wrench. Expansion Blade. Loosens or tightens nipples, pipes & fittings.	5
385	1" Internal Pipe Wrench. Expansion Blade. Loosens or tightens nipples, pipes & fittings.	5

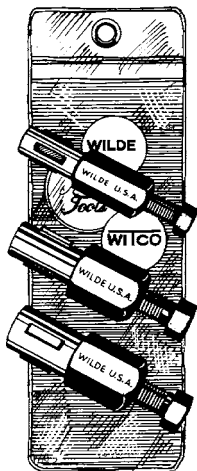

9033D	3-Pc. Internal Pipe Wrench Set. Contains one each #380, 383 and 385 in a hang-up, sturdy vinyl kit.	5
-------	---	---

NOTE: Internal Pipe Wrench eliminates damage to threads, walls and high polished finish.



FLARING TOOLS & TUBING CUTTERS	Cat. No.	Description	Std. Pk.
--------------------------------	----------	-------------	----------

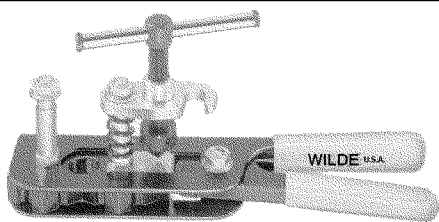

400-45 Flaring Tool produces single 45° lap flares in six sizes of tubing, 3/16", 1/4", 5/16", 3/8", 1/2" and 5/8" O.D. 5

PLIERS

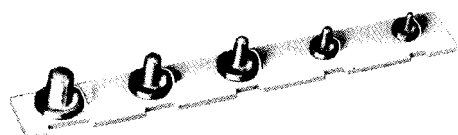

400-AD Form-A-Gage for #400-45. Produces double lap flares in five sizes of tubing, 3/16", 1/4", 5/16", 3/8", 1/2" O.D. 5

PUNCHES, CHISELS & PRY BARS

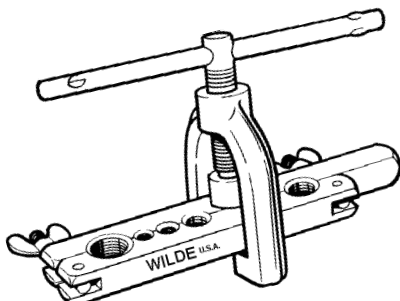

200 Flaring Tool makes S.A.E. 45° flare joints. Flares 3/16", 1/4", 5/16", 3/8", 7/16", 1/2", 5/8" O.D. 5

WRENCHES

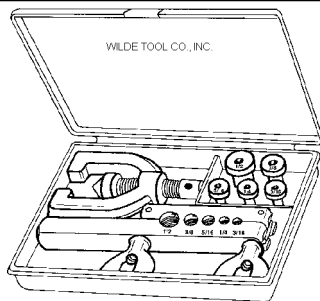

250DF Double Flaring Tool. Double flares 3/16", 1/4", 5/16", 3/8" & 1/2" O.D. In sturdy vinyl box. 5

SCREWDRIVERS

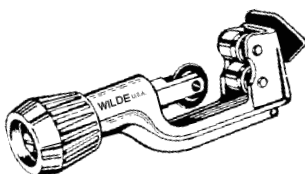

300 Tubing Cutter 1/8" to 1-1/8" O.D. Cutting wheel adjustment is internal. 5

350 Tubing Cutter 1/8" to 1-1/8" O.D. Cutting wheel adjustment is external. 5

PLUMBING & INDUSTRIAL

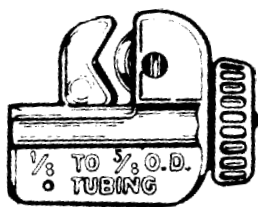

325 Midget Tubing Cutter. No rollers. Plated. 1/8" to 5/8" O.D. 3mm to 16mm O.D. 10

AUTOMOTIVE

SERVICE TOOLS



300W Cutter Wheel only for #300. 5
 325W Cutter Wheel only for #325. 5
 350W Cutter Wheel for #350. Also fits most popular brands. 5

DISPLAYS

HACK SAW & BLADES TORCH LIGHTER SET	Cat. No.	Description	Std. Pk.
--	-------------	-------------	-------------



553 Close quarters hand held hack saw. 5
Accepts all standard hack saw blades.
Can be used with broken blades of 4"
or more. Blade included.

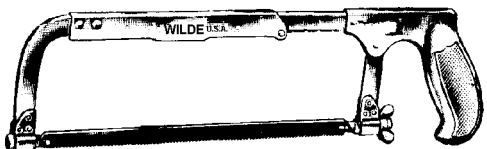

453 Pistol Grip Hack Saw, all metal 5
frame. Adj. for 8, 10 & 12
inch blades. Blade can be
moved to 4 positions. Frame
does not fall apart when blade
is removed. 10" Blade included.

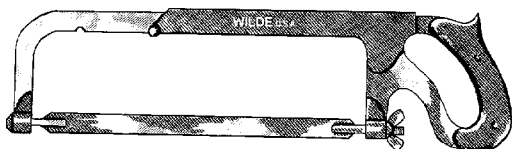

653 DeLuxe Pistol Grip Hack Saw. 5
Extra heavy. High quality.
Blade can be moved to 4
positions. Frame does not fall
apart when blade is removed.
Adj. for 8, 10 & 12 inch blades.
10" Blade included.

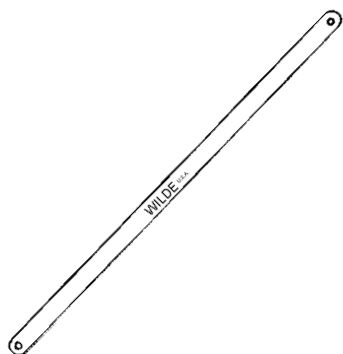

218 12" Hack Saw Blade. 18 Teeth/ 10
inch. Spring tempered alloy steel,
shatterproof.

224 12" Hack Saw Blade. 24 Teeth/ 10
inch. Spring tempered alloy steel,
shatterproof.

232 12" Hack Saw Blade. 32 Teeth/ 10
inch. Spring tempered alloy steel,
shatterproof.

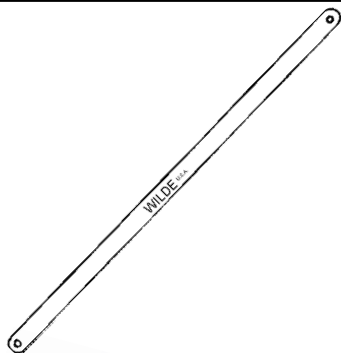

418 12" Economy Hack Saw Blades. 10
18 Teeth/inch.

424 12" Economy Hack Saw Blades. 10
24 Teeth/inch.

432 12" Economy Hack Saw Blades. 10
32 Teeth/inch.

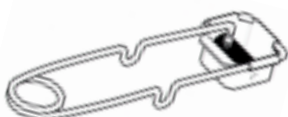

144 Torch Lighter made of heavy spring 10
wire. Round type file with shield.
8" Long.



144T Torch Lighter Renewal Tips. 40
5 tips per pack.

PLIERS
PUNCHES, CHISELS
& PRY BARS
WRENCHES
SCREWDRIVERS
PLUMBING &
INDUSTRIAL
AUTOMOTIVE
SERVICE TOOLS
DISPLAYS



HEX KEY WRENCHES & SETS **Cat. No.** **Description** **Std. Pk.**

L-SHAPE HEX KEY WRENCH

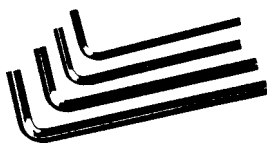
		Size	Fits Set Screw	Fits Cap Screw	
	55	1/16"	5 & 6	2	100
	55A	5/64"	8	4	100
	56	3/32"	10	5 & 6	100
	57	1/8"	1/4"	8	100
	58	5/32"	5/16"	10	100
	59	3/16"	3/8"	1/4"	100
	60	7/32"	7/16"	5/16"	100
	61	1/4"	1/2" & 9/16"	-	100
	62	5/16"	5/8"	3/8" & 7/16"	100
	63	3/8"	3/4"	1/2"	50
	52R	10-Pc. Set Screw Wrench Set. Contains one each #55 to 63 incl., in vinyl kit.			5

PLIERS
PUNCHES, CHISELS & PRY BARS
WRENCHES
SCREWDRIERS
PLUMBING & INDUSTRIAL
AUTOMOTIVE
SERVICE TOOLS
DISPLAYS

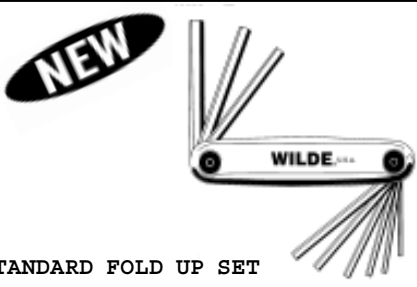
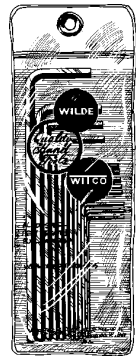

53R	9-Pc. Fold Up Hex Key Wrench Set. Contains one each 5/64", 3/32", 7/64", 1/8", 9/64", 5/32", 3/16", 7/32" and 1/4".	10
-----	---	----

STANDARD FOLD UP SET

T-HANDLE HEX KEYS

	Size	Length	Handle Width	
606E	3/32"	6"	3"	20
607E	7/64"	6"	3"	20
608E	1/8"	6"	3"	20
609E	9/64"	6"	3"	20
610E	5/32"	6"	3"	20
612E	3/16"	6"	4"	20
614E	7/32"	6"	4"	20
616E	1/4"	6"	4"	20
620E	5/16"	6"	6"	10
624E	3/8"	6"	6"	10
9106E	10-Pc. T-Handle Hex Key Set. Contains one each #606E to 624E inclusive in vinyl kit.			6

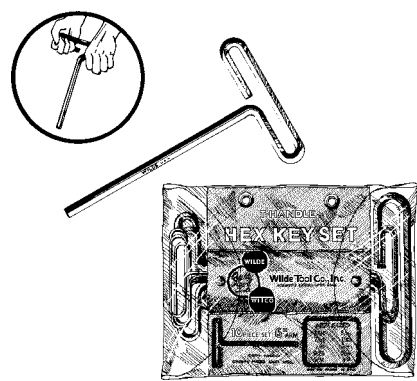

BALL TIP L-SHAPE HEX KEY WRENCH

	Size	Length		
902B	.050"	2.8"	20	
903B	1/16"	3.0"	20	
904B	5/64"	3.2"	20	
905B	3/32"	3.4"	20	
906B	7/64"	3.6"	20	
907B	1/8"	3.7"	20	
908B	9/64"	3.9"	20	
909B	5/32"	4.1"	20	
910B	3/16"	4.5"	20	
911B	7/32"	4.9"	20	
912B	1/4"	5.2"	20	
913B	5/16"	6.0"	10	
914B	3/8"	6.7"	5	
9139B	13-Pc. Ball Tip L-Shape Hex Key Set. Contains one each #902B to 914B inclusive in vinyl kit.			5



SCREW EXTRACTORS & HAMMERS

Cat. No. Description Std. Pk.

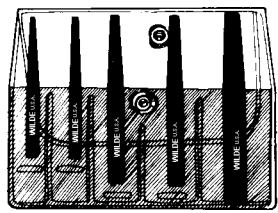
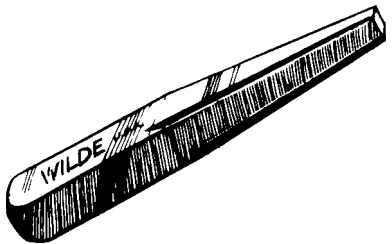

	Bolt Size	Pipe Size	Drill	
91	1/4"-5/16"	1/8"	1/8"	10
92	3/8"		3/16"	10
93	7/16"	1/8"	15/64"	10
94	1/2"-9/16"	1/4"	5/16"	10
95	5/8"	3/8"	3/8"	10
96	3/4"		15/32"	10
97	7/8"	1/2"	9/16"	10
98	1"-1-1/8"	1/2"	21/32"	10
99	1-1/4"-1-3/8"	3/4"	13/16"	10
89	4-Pc. Screw Extractor Set. Contains one each # 96, 97, 98 and 99, in a heavy, durable leatherette pouch.			5
90	5-Pc. Screw Extractor Set. Contains one each #91, 92, 93, 94 and 95 in a sturdy vinyl kit.			5



1001	16 oz. Curved Claw Hammer. Octagon neck. Supersteel. Flame treated hickory handle. 13".	4
1002	20 oz. Ripping Claw Hammer. Handle triple-wedged in eye for "Sure-Lock" fit. Flame treated hickory handle. 14".	4

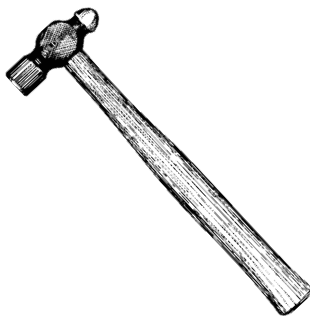

1003	8 oz. Ball Pein. Hickory handle. Black finish with polished face and pein. Chamfered face. 11-5/8".	4
1004	16 oz. Ball Pein. Hickory handle. Black finish with polished face and pein. Chamfered face. 14-1/4".	4
1005	24 oz. Ball Pein. Hickory handle. Black finish with polished face and pein. Chamfered face. 14-3/4".	4
1006	32 oz. Ball Pein. Hickory handle. Black finish with polished face and pein. Chamfered face. 15-1/4".	4

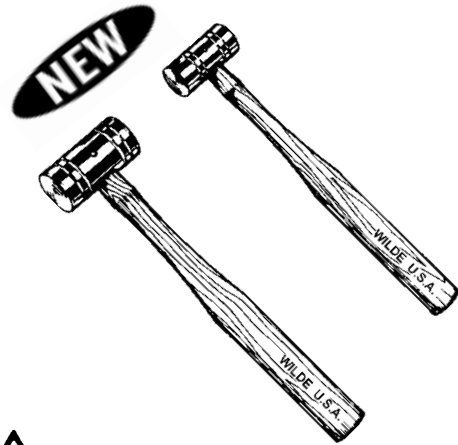

1008	8 oz. BRASS hammer. 10" OAL. 1" face diameter. 2.1" head.	5	Non-marring. Non-sparking. Handcrafted in the USA. Handle secured with brass pin.
1016	16 oz. BRASS hammer. 10 OAL. 1.25" face diameter. 2.6" head.	5	Heads are turned from quality 360 brass & hand polished.
1032	32 oz. BRASS hammer. 13" OAL. 1.5" face diameter. 4" head.	5	Used in machine shops, industrial, automotive & gunsmithing trades where hard drives are required to steel or iron surfaces without damage.
1080	80 oz. BRASS hammer. 16" OAL. 1.88" face diameter. 4.65" head.	5	



PLIERS
PUNCHES, CHISELS & PRY BARS
WRENCHES
SCREWDRIVERS
PLUMBING & INDUSTRIAL
AUTOMOTIVE
SERVICE TOOLS
DISPLAYS

SLEDGE HAMMERS

Cat. No.	Description	Std. Pk.
----------	-------------	----------

- PLIERS
- PUNCHES, CHISELS & PRY BARS
- WRENCHES
- SCREWDRIVERS
- PLUMBING & INDUSTRIAL
- AUTOMOTIVE
- SERVICE TOOLS
- DISPLAYS

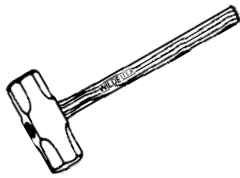

2DF	2 lb. Double Faced Sledge. Forged Steel. Heat Treated. 1-3/8" Face. 16" Length.	5
2-1/2DF	2-1/2 lb. Double Faced Sledge. Forged Steel. Heat Treated. 1-1/2" Face. 16" Length.	5
3DF	3 lb. Double Faced Sledge. Forged Steel. Heat Treated. 1-5/8" Face. 16" Length.	5
4DF	4 lb. Double Faced Sledge. Heat Treated. 1-3/4" Face. 16" Length.	5

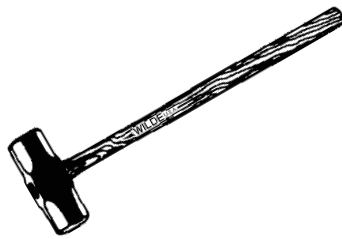

6DF	6 lb. Double Faced Sledge. Forged Steel. Heat Treated. 2-1/8" Face. 36" Length.	5
8DF	8 lb. Double Faced Sledge. Forged Steel. Heat Treated. 2-1/4" Face. 36" Length.	5
10DF	10 lb. Double Faced Sledge. Forged Steel. Heat Treated. 2-1/2" Face. 36" Length.	5
12DF	12 lb. Double Faced Sledge. Forged Steel. Heat Treated. 2-5/8" Face. 36" Length.	5
20DF	20 lb. Double Faced Sledge. Forged Steel. Heat Treated. 3-1/8" Face. 36" Length.	2

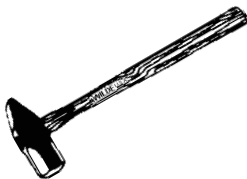

2CP	2 lb. Cross Pein Sledge. Forged Steel. Heat Treated. 1-3/8" Face. 16" Length.	5
3CP	3 lb. Cross Pein Sledge. Forged Steel. Heat Treated. 1-5/8" Face. 16" Length.	5
4CP	4 lb. Cross Pein Sledge. Forged Steel. Heat Treated. 1-3/4" Face. 16" Length.	5

AVIATION & METAL CUTTING TIN SNIPS Cat. No.

Description

Std. Pk.

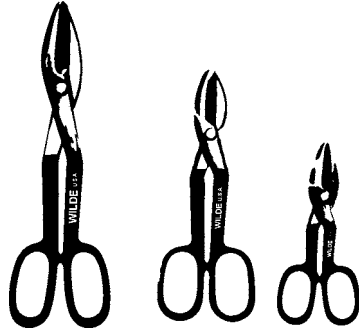

1SN Straight Pattern Snips. 1-3/4" Cutting edge. 7" Long.

2SN Straight Pattern Snips. 2-1/2" Cutting edge. 10" Long.

3SN Straight Pattern Snips. 3" Cutting edge. 12" Long.

12 • Hot drop-forged steel.

• Roll polish finish.

12 • Use traditional straight blade pattern snips for cutting wide curves to the left or right and for power straight cuts.



4SN Circular Pattern Snips. 1-3/4" Cutting edge. 7" Long.

5SN Circular Pattern Snips. 2-1/2" Cutting edge. 10" Long.

6SN Circular Pattern Snips. 3" Cutting edge. 12-3/4" Long.

12 • Hot drop-forged steel.

• Roll polish finish.

12 • Use circular blade pattern snips for cutting wide tight curves to the left or right and for cutting straight.

SPRING ACTIVATED LATCH

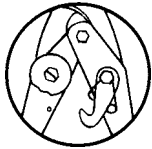

CANNOT CLOSE ACCIDENTLY

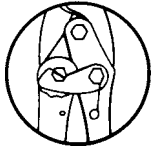

8SN 10" **RIGHT CUT** Aviation Snip. Green grips. 1-3/8" Cutting edge. Serrated blade. Heat treated alloy steel. Compound leverage.

10 • Moly steel & austemper heat treated for long-lasting cutting edge.

• Both blades serrated optimum 40 serrations per inch for maximum gripping power without scanning material.



9SN 10" **STRAIGHT CUT** Aviation Snip. Yellow grips. 1-1/2" Cutting edge. Serrated blade. Heat treated alloy steel. Compound leverage.

10 • Grade 8 center pivot bolt threaded into bottom blade to keep blades in adjustment longer and hold blade readjustment after extensive use.

• Heavy-duty half hard steel handles will not collapse from hand pressure.



10SN 10" **LEFT CUT** Aviation Snip. Red grips. 1-3/8" Cutting edge. Serrated blade. Heat treated alloy steel. Compound leverage.

10 • These regular blade pattern models are strong and versatile and can be used to cut a multitude of sheet materials.

PLIERS

PUNCHES, CHISELS & PRY BARS

WRENCHES

SCREWDRIVERS

PLUMBING & INDUSTRIAL

AUTOMOTIVE

SERVICE TOOLS

DISPLAYS



NOTES



AUTOMOTIVE TOOLS

SWIVEL TYPE OIL FILTER WRENCHES

Unique Yoke and Link Assembly allows for a positive grip. Offering 2 popular sizes. For filters ranging in size from 2-7/8" - 3-1/4" and 4" - 4-3/8".

See Page 61.

NEW

ADJUSTABLE OIL FILTER PLIER

Self adjusting, spring action plier. Allows for a full range of filter applications (2-1/4"-6"). Heavy duty forged handles for strength and leverage. Gripped.

See Page 61.

VALVE LIFTERS

Heavy duty design. Hand, toggle and air operated for all types of valve work. Our complete line handles the most difficult valve jobs. All valve lifters are properly heat treated and plated.

See Pages 60 & 61.

RING COMPRESSORS

Adaptive to all types of rings, brake being strong enough for the stiffest rings. Beaded edge prevents compressor from entering cylinder with piston. Will not oval or egg shape around piston skirt. 1, 2 or 4 tension bands available depending on the size of the piston.

See Page 64.

PULLERS

Adjustable and reversible two and three jaw pullers. All built to withstand hard usage. Contrasting cadmium and black oxide. Steering Wheel Puller, Ball Joint Separator and Tie Rod End Pullers also available.

See Pages 62 & 63.

FEELER GAUGES

Precision Gauges made of Imported Swedish Feeler Steel, hardened and tempered for long wear, ground and polished to an accuracy of one ten thousandths of an inch. All gauges are equipped with knurled lock nuts for quick release of blades facilitating the selection of size desired and also insertion of new blades. Sizes are permanently etched on blades.

See Pages 65.

RING GROOVE CLEANER

For removing carbon from piston ring grooves from smallest to 6" without chattering, gouging, catching in oil holes or climbing out of groove. Rigid frame and radially held cutter prevents tilting which causes damage to the sides of the groove or cutting the bottom of the groove at an angle. Plated finish.

See Page 64.

HONES

For brake cylinder work for servicing small engines. Strongly built, self-aligning, self-centering. Built to bottom in blind holes or resurface step-cylinders. Fine, medium and coarse grit stones available.

See Page 58.

GLAZE BREAKERS

Flexible shaft stone type with long resilient spring action which forces the abrasive stones against the cylinder wall for proper glaze breaking and constantly maintained correct cutting pressure. Adjustable and preset tension. Fine, Medium and Coarse Stones available.

See Page 59.

PLIERS

PUNCHES, CHISELS
& PRY BARS

WRENCHES

SCREWDRIVERS

PLUMBING &
INDUSTRIAL

AUTOMOTIVE

SERVICE TOOLS

DISPLAYS



HONES

Cat. No. Description Std. Pk.

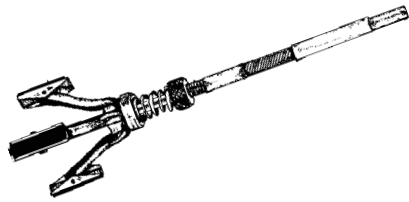

63DG Brake Cylinder Hone. Adjustable Tension. Flexible Shaft. 3/4" to 2-1/2" diameter. 1-1/8" Medium Grit Stones. Carded. 5

PLIERS

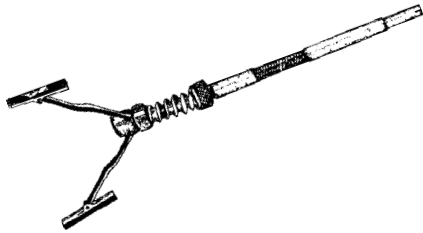

64FDG Brake Cylinder Hone for most small cars/Imports. Adjustable Tension. Flexible Shaft. 1/2" thru 2-1/2" diameter. 1-1/8" Medium Grit Stones. Carded. 5

PUNCHES, CHISELS & PRY BARS

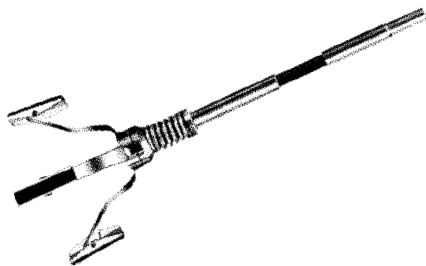

67DG Brake Cylinder Hone. Preset Tension, self-adjusting spring. Flexible Shaft Expansion is controlled on a flat surface. 3/4" to 2-1/4" diameter. 1-1/8" Medium Grit Stones. Carded. 5

WRENCHES

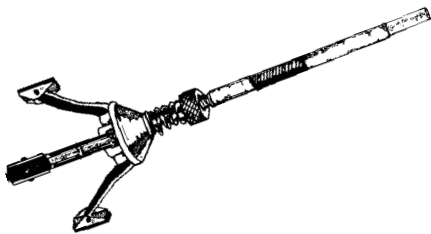

68 Cylinder Hone for Cycle, Lawnmower & Outboard shops. Flexible Shaft. Capacity 1-1/4" to 3-1/2" diameter. 3/4" Stones. Carded. 5

SCREWDRIVERS

PLUMBING & INDUSTRIAL

68A Same as #68 except with 2" Stones. 5

AUTOMOTIVE

SERVICE TOOLS

DISPLAYS

Fine Grit = 400
Medium Grit = 240
Coarse Grit = 100

63-1 1-1/8" Medium Grit Stone Set 10 for 63DG, 67DG

63-14 1-1/8" Fine Grit Stone Set. 5 for 63DG, 67DG

63-100 1-1/8" Coarse Grit Stone Set. 5 for 63DG, 67DG

63-21 2" Medium Grit Stone Set. 5 for 63DG, 67DG, 68A

63-24 2" Fine Grit Stone Set. 5 for 63DG, 67DG, 68A

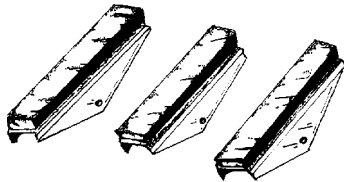

63-34 3/4" Fine Grit Stone Set. 5 for 63DG, 67DG, 68

64-1 1-1/8" Medium Grit Stone Set. 5 for 64FDG

64-14 1-1/8" Fine Grit Stone Set. 10 for 64FDG

GLAZE BREAKERS

Cat. No.	Description	Std. Pk.
----------	-------------	----------

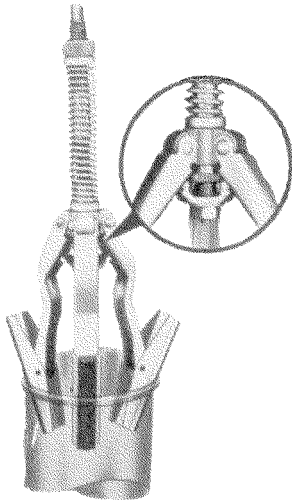

60DGS	Glaze Breaker. Stone type. 2" to 5-1/2" dia. 3" Long Medium Grit Stones. Carded.	5
-------	--	---

61DG	Glaze Breaker. Preset Tension. Flexible Shaft. 2" to 5" dia. 3" Long Medium Grit Stones. Carded.	5
------	--	---

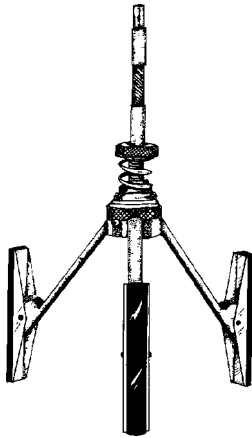

62DG	Large Glaze Breaker. Preset Tension. Flexible Shaft. 2" to 7" dia. 4" Long Medium Grit Stones. Carded.	5
------	--	---

62DGS	Large Glaze Breaker. Stone Type. 2" to 7" dia. 4" Long Medium Grit Stones. Carded.	5
-------	--	---

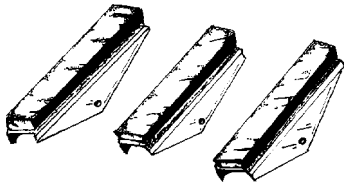

61-1S	3" Coarse Grit Stone Set.	10	for 60DGS, 61DG, 62DG, 62DGS
-------	---------------------------	----	------------------------------

61-2S	3" Medium Grit Stone Set.	10	for 60DGS, 61DG, 62DG, 62DGS
-------	---------------------------	----	------------------------------

61-4S	3" Fine Grit Stone Set.	10	for 60DGS, 61DG, 62DG, 62DGS
-------	-------------------------	----	------------------------------

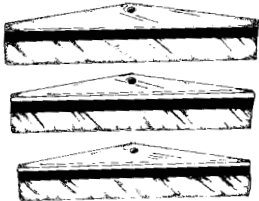

62-2S	4" Medium Grit Stone Set.	10	for 62DG, 62DGS
-------	---------------------------	----	-----------------

62-4S	4" Fine Grit Stone Set.	10	for 62DG, 62DGS
-------	-------------------------	----	-----------------

PLIERS

PUNCHES, CHISELS & PRY BARS

WRENCHES

SCREWDRIVERS

PLUMBING & INDUSTRIAL

AUTOMOTIVE

SERVICE TOOLS

DISPLAYS



VALVE LIFTERS

Cat.
No.

Description

Std.
Pk.

- PLIERS
- PUNCHES, CHISELS & PRY BARS
- WRENCHES
- SCREWDRIVERS
- PLUMBING & INDUSTRIAL
- AUTOMOTIVE
- SERVICE TOOLS
- DISPLAYS

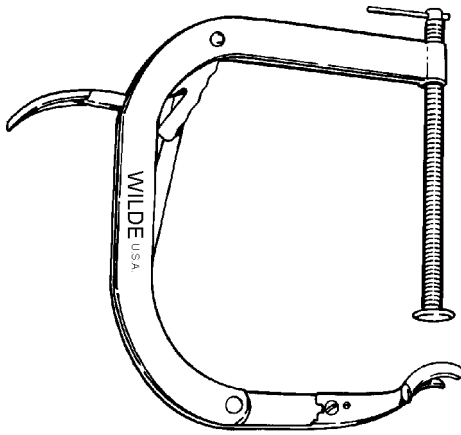

615

"C" Clamp Valve Lifter. 10-1/2" High, 9-3/4" Wide. Cap. 1" to 2-1/2". Comes with 3 sets of jaws, #612, 613C & 608. Quick Change Jaws.

1

#615 designed for "L" head & valve-in engines. One handed control lock & release. Spring release frees other hand for replacing keepers or locks on valve stem. Quickly adjusts for any valve stem length. One simple adjustment with pin operated screw on the first set of valves sets clamp for the balance of the springs. Heavy duty cam locking handle gives leverage for handling the stiffest of springs. Full thread length on screw adjusting post provides maximum capacity.

613C

Medium offset jaws fit #615 & #700. Cap. 1" to 2". Jaws are pictured on #615.

5

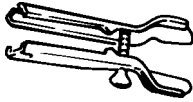

608

Large Straight Jaws fit #615 & #700. Cap. 1-1/2" to 2-1/2".

5



612

Small Straight Jaws fit #615 & #700. Cap. 7/8" to 1-3/4".

5

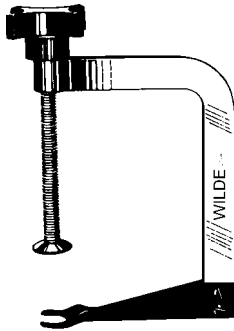

600

Small Engine Valve Lifter. For air or water cooled 4-cycle engines with spring diameter up to 1-1/16".

5



600-3A

Small Jaw replacement for #600.

5



600-3B

Large Jaw replacement for #600.

5

**VALVE LIFTERS &
OIL FILTER WRENCHES**

Cat.
No. Description

Std.
Pk.

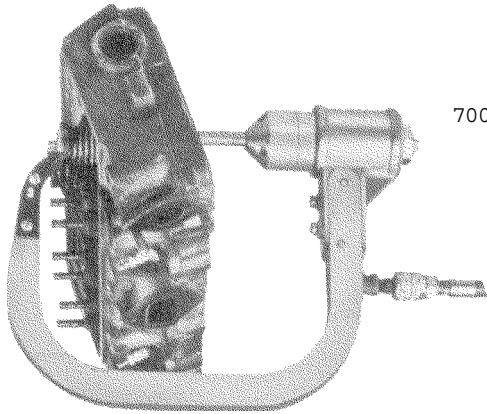

700

Air Operated "C" Clamp Valve Lifter. Equipped with three pairs of jaws, #608, 612 & 613C. Height 9-3/4". Width 7". Cap. 1" to 2-1/2".

1

#700 Just 2 fingers do the work! Fully controlled "C" type valve lifter that compresses the heaviest springs in a fraction of a second. Controlled release action is a must when keys or keepers are being replaced. Operates with on-line pressure of 90-125 lbs. & develops pressure equal to 3X the line pressure. Features completely paralleled lift that will not bend valve stem. Ideal for all late model cars, trucks, buses, tractors, marine & industrial engines.

PLIERS

PUNCHES, CHISELS & PRY BARS

WRENCHES



513

Oil Filter Wrench. Capacity 2-7/8" - 3-1/4". Swivel type. Unique yoke and link assembly for positive grip.

5

514

Oil Filter Wrench. Capacity 4" - 4-3/8". Swivel type. Unique yoke and link assembly for positive grip.

5

SCREWDRIVERS

PLUMBING & INDUSTRIAL

AUTOMOTIVE

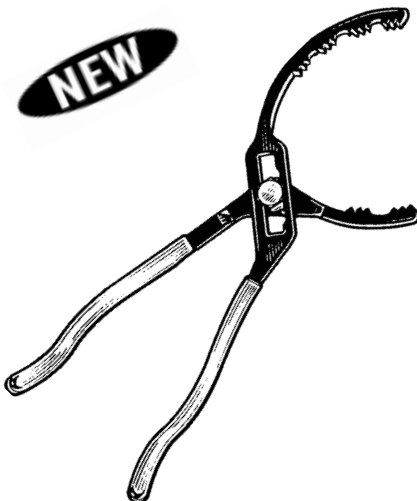

515

Adjustable Oil Filter Plier. Self adjusting, spring action plier allows for a full range of filter applications (2-1/4"-6"). Heavy duty forged handles for strength and leverage. Grippled.

5

SERVICE TOOLS

DISPLAYS



PULLERS

Cat. No.	Description	Std. Pk.
----------	-------------	----------

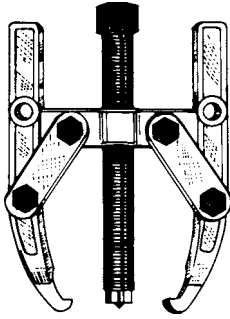

950	4" Adjustable 2 Jaw Gear Puller. 2 Positions. Reach 3-1/2". Spread 4". Center Screw 3/8"-24 x 4-3/4". 2 Ton.	5
-----	--	---

- Forged alloy steel.
- Fully heat treated.
- Contrasting bright luster plate & black oxide.

952	7" Adjustable 2 Jaw Gear Puller. 2 Positions. Reach 5-1/2". Spread 7". Center Screw 9/16"-20 x 6-3/8". 5 Ton.	5
-----	---	---

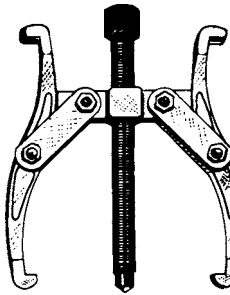

954	6" Reversible 2 Jaw Gear Puller. Reach 3-1/2". Spread 6". Center Screw 9/16"-20 x 6-3/8". 5 Ton. Jaws have wide faces on one end & narrow faces on the other.	5
-----	--	---

956	9" Reversible 2 Jaw Gear Puller. Reach 5-1/2". Spread 9". Center Screw 11/16"-18 x 9-3/32". 7 Ton. One end of jaw has a slot for cap screw pulling of tapped gears & pulleys.	5
-----	--	---

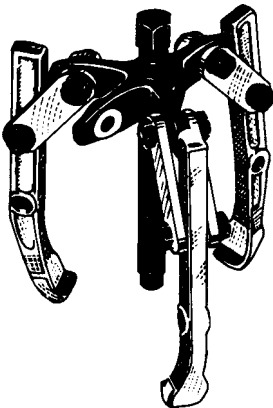

951	4" Adjustable 3 Jaw Gear Puller. 3-Jaw feature gives added stability. Reach 3-1/2". Spread 4". Center Screw 3/8"-24 x 4-1/4". 2 Ton.	5
-----	---	---

953	8" Adjustable 2 & 3 Jaw Gear Puller. 2 Positions. Reach 5-1/2", Spread 8". Center Screw 9/16"-20 x 6-3/8". 5 Ton.	5
-----	---	---

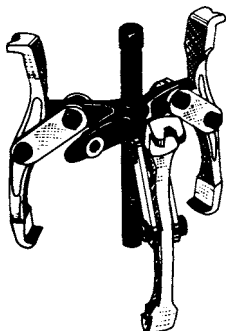

955	7" Reversible 2 & 3 Jaw Gear Puller. Reach 3-1/2". Spread 7". Center Screw 9/16"-20 x 6-3/8". 5 Ton.	5
-----	--	---

957	10" Reversible 2 & 3 Jaw Gear Puller. Reach 5-1/2". Spread 10". Center Screw 11/16"-18 x 9-3/32". 7 Ton.	5
-----	--	---

PLIERS

PUNCHES, CHISELS & PRY BARS

WRENCHES

SCREWDRIVERS

PLUMBING & INDUSTRIAL

AUTOMOTIVE

SERVICE TOOLS

DISPLAYS

PULLERS

Cat. No.	Description	Std. Pk.
----------	-------------	----------

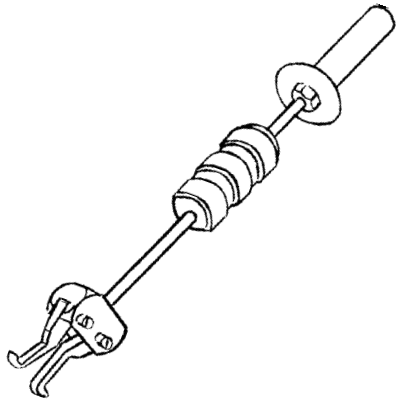

958	Pilot Bearing Puller for removing sleeve type bearings from 1/2" to 1-1/2" inside dia. Center rod spreads jaws for tight fit. A few light taps with the sliding hammer and the bearing is removed. Individually boxed. Center Rod is 1/2" - 13 x 13".	5
-----	---	---

PLIERS

PUNCHES, CHISELS & PRY BARS

WRENCHES

SCREWDRIVERS

PLUMBING & INDUSTRIAL

AUTOMOTIVE

SERVICE TOOLS

DISPLAYS

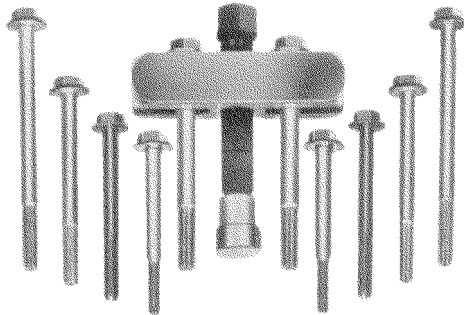

959	Steering Wheel Puller. Cross arm is 4" long, made of 1" square steel. Center screw is 5/8-18 x 5". The center screw has a floating swivel for maximum flexibility. Five sets of screws included: 2 each 1/4" - 28 x 3". 2 each 5/16" - 24 x 3-1/2". 2 each 5/16" - 18 x 4-1/2". 2 each 3/8" - 16 x 4". 2 each M8 - 1.25 x 80mm.	5
-----	--	---

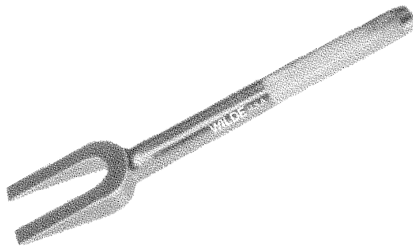

962	Ball Joint Separator. Made of alloy heat-treated steel forging, bright luster plate finish. Individually boxed. Opening 15/16", Length 11-7/8".	5
-----	---	---



964	Tie Rod End Puller. Made from single piece of alloy heat-treated drop forging. Bright luster plate finish. Individually boxed. Opening 21/32", Length 11-7/8".	5
-----	--	---



RING TOOLS

Cat. No. Description Std. Pk.

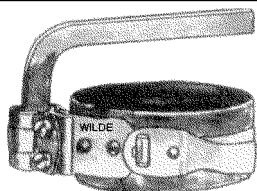

44 Outboard Motor Ring Compressor. Band is 13/16" high. Range 1-3/8" to 3-1/2". Release catch opens for quick removal. 5

44-2 Twin Compressor Set and handle. 5 #44-2 TO BE DISCONTINUED WHEN STOCK IS DEPLETED

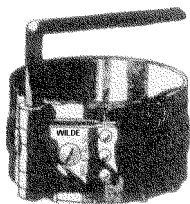

48 Midget Ring Compressor for foreign cars and small gas engines. 2" high compression band. Cap. 1-1/2" to 3". 5

51 Piston Ring Compressor. Adaptable to all types of rings. 2-1/2" high compression band. Range 2-1/8" to 5". 5

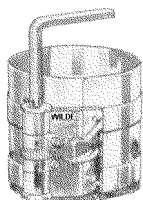

66 Ring Compressor, Ratchet type. Self locking, heavy duty ratchet. 3-1/2" Twin bands. Range 2-1/8" to 5". 5

67 Ring Compressor, Ratchet Self locking, heavy duty ratchet. 3-1/2" Twin bands. Range 3-1/2" to 7". 5

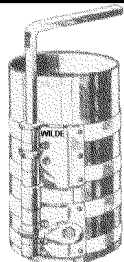

69 Jumbo Ring Compressor for Bus and Tractor. 4 Tension Bands and 2 winding spools. 6-1/2" High. Range 3-1/2" to 7". 5

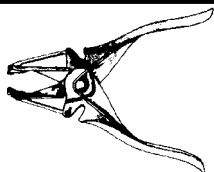

31 Piston Ring Expander. Handles all sizes of piston rings. Flat gripping surface will not damage rings. Heat treated, plated finish. 6-1/2" Long. 5

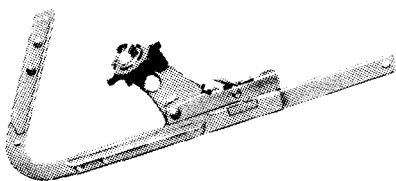

49 Ring Groove Cleaner. Rigid frame and radially held cutter. Compensating spring. Cutter wheel sizes below. 5

47 Ring Groove Cleaner, (for late V8 motors). Cutter wheel includes sizes below. 5

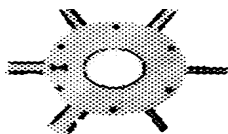

47A 2 Extra Cutters in 1/16", 5/64", 3/32", 1/8", 5/32", 3/16" and in Metric 2mm, 2.5mm, 3.0mm, 4.0mm and 4.5mm. 5

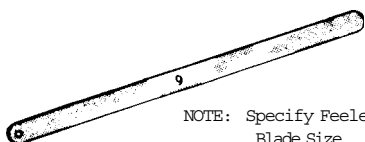

NOTE: Specify Feeler Gauge Blade Size.

512B Six 12" Blades .003 to .028 incl. 1
 512BE Six 12" Blades .0015 and .002 1
 512BL Six 12" Blades .030, .032, .035, .040 1

PLIERS

PUNCHES, CHISELS & PRY BARS

WRENCHES

SCREWDRIVERS





PLUMBING & INDUSTRIAL

AUTOMOTIVE

SERVICE TOOLS

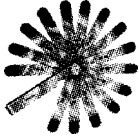
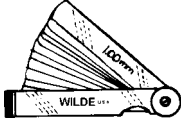
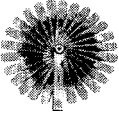
DISPLAYS

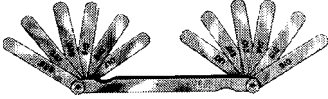
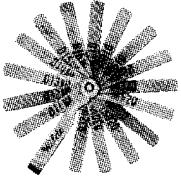
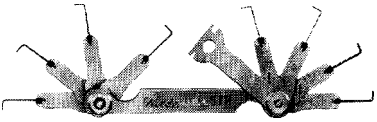
GAUGES

	Cat. No.	Description	Std. Pk.	Blade Measurements		
	476	GO-NO-GO Gauge. Contains fifteen 1/2" wide by 3-5/16" long step ground blades.	5	.006/.008 .007/.009 .008/.010 .009/.011 .010/.012 .011/.013 .012/.014 .013/.015	.014/.016 .015/.017 .016/.018 .017/.019 .018/.020 .019/.021 .020/.022	
	499	Metric Ignition Gauge. Contains thirteen 1/2" x 3" blades.	5	.050 .100 .150 .200	.250 .300 .400 .500 .600	.600 .700 .800 .900 1.000
	500	Master Gauge. Contains twenty-five 1/2" wide by 3" long blades.	6	.0015 .002 .003 .004 .005 .006 .007 .008 .009	.010 .011 .012 .013 .014 .015 .016 .018	.020 .022 .024 .025 .028 .030 .032 .035
	501	Standard Gauge. Contains ten 1/2" wide by 3" long blades.	5	.002 .003 .004 .005	.006 .007 .008	.010 .012 .015
	504	Ignition Gauge. Contains twelve 1/4" wide by 1-3/4" long blades.	5	.011 .012 .013 .014	.015 .016 .017 .018	.019 .020 .022 .025
	510	Master Ignition Gauge. Contains sixteen 1/4" wide by 1-3/4" long blades.	5	.011 .012 .013 .014 .015 .016	.017 .018 .019 .020 .022	.024 .025 .028 .030 .032
	578	Spark Plug Gauge. Contains eight 90° offset wire blades. One electrode bending tool.	5	.020 .025 .028	.030 .032 .034	.035 .040
	589	Universal O.H.V. Gauge for V8 engines. Contains sixteen 1/2" wide by 3-5/16" long blades with 45° offset for checking valve clearances.	5	.009 .010 .011 .014 .015 .016	.017 .018 .019 .020 .021	.023 .024 .025 .026 .027

PLIERS

PUNCHES, CHISELS & PRY BARS

WRENCHES

SCREWDRIVERS

PLUMBING & INDUSTRIAL

AUTOMOTIVE

SERVICE TOOLS

DISPLAYS



NOTES



SERVICE TOOLS

BLOW GUNS

Pressure guns with trigger controlled air from a whisper to full line pressure. Spring loaded control valve with no cut-off. Cadmium plated for long life.

See Page 68.

SCRAPERS & AWLS

Gasket scraper made of forged alloy steel with a sharp chisel edge. Insulite handle. The scratch awls are a tough, hard tool steel punch. Goes through body metal.

See Page 71.



NEW SCRAPER SIZES

Same style as our standard one scraper. One with exposed blade of 5" x 1" face and the other 8" x 1/2".

See Page 71.

HOSE CLAMP PLIERS

For removing and installing spring wire hose clamps. Deep slots in jaws hold clamp securely. Pawl automatically locks plier in any of three positions. Jaws swivel through 180°.

See Page 72.

INSPECTION MIRRORS

A complete line of inspection mirrors for industrial, electronic, aircraft and automotive uses. Your choice of Oval, Round or Rectangular shape mirrors. Some have telescopic handles and adjustable heads. Replacement mirrors available.

See Page 69.

MAGNETIC PICK-UP TOOLS

Contain a powerful Alnico Magnet, retrieves metal objects in hard to reach places. Your choice of handles, either flexible, telescopic or pocket styles available.

See Page 70.

MECHANICAL FINGER

Can be used as a temporary clamp for small parts. Can be bent into an S shape or at 90° without springing back. Has 15" reach. For retrieving small parts or pulling wires through dashes.

See Page 70.

AXLE RETHREADING DIE

Can be used for rethreading axles without removing the axle from the housing. The Die is split for quick application and is fitted to the threads at the back end of the axle and rechases threads through the damaged portion. Drop forged steel, Heat Treated, Nickel plated.

See Page 72.

HOOK AND PICK SET

Ideal for separating wires, removing small fuses, "O" rings, retrieving washers and loose parts too small to pick up with your fingers. Each hook and pick is made of high carbon polished steel and is permanently attached to a hex shaped aluminum handle.

See Page 70.

FLEXIBLE DRIVERS

A versatile tool with swivel head and a flexible working end which can be bent to reach difficult places. Long enough and small enough to slip between wires and other obstructions.

See Page 72.

HEADLIGHT SPRING TOOL

Special punched end allows pushing or pulling against spring tension. Hardened bit is nickel-chrome plated with fluted plastic handle.

See Page 71.

COTTER KEY EXTRACTOR

Work in like a cork screw and zip cotter keys out on brake assemblies etc. Also useful for removing snap lock rings, or removing the rubber seats at the bottom of replaceable seats on International line of trucks and tractors.

See Page 71.



EXTENDED LENGTH COTTER KEY EXTRACTOR

Where longer reach is necessary. Used in all markets, especially aircraft industry.

See Page 71.

PLIERS

PUNCHES, CHISELS & PRY BARS

WRENCHES

SCREWDRIVERS

PLUMBING & INDUSTRIAL

AUTOMOTIVE

SERVICE TOOLS

DISPLAYS



BLOW GUNS

Cat. No. Description Std. Pk.

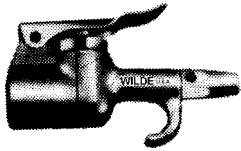

301S Short Nozzle Blow Gun. Spring loaded control valve with no cut off. 2-1/8" Long. Full line pressure nozzle, single finger control. Meets OSHA requirements. 5

PLIERS

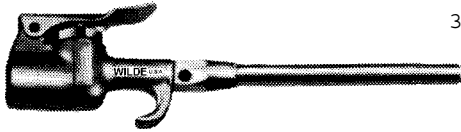

302S Medium Tube Blow Gun. Same as #301S but with 4" Tube Nozzle. 6-1/8" Overall Length. Meets OSHA requirements. 5

PUNCHES, CHISELS & PRY BARS



303S Long Tube Blow Gun. Same as #301S but with 9-7/8" Tube Nozzle. 12" Overall Length. Tubes may be bent for individual use. Meets OSHA requirements. 5

WRENCHES

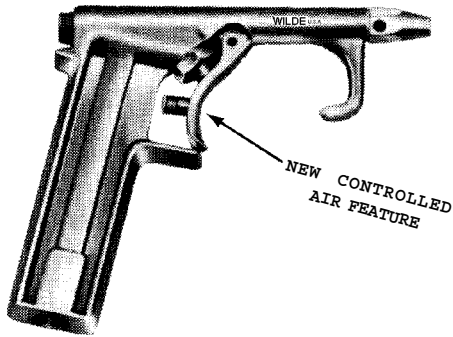

321S Controlled Air Blow Gun. Dual Air Inlets for Overhead air source or underbench or floor air source. Interchangeable Plug, Pistol Grip Handle Front Hanging Hook. Meets OSHA Requirements when used on line pressure from 100 to 135 PSI. Will deliver 30PSI or less. 5

SCREWDRIVERS

PLUMBING & INDUSTRIAL

AUTOMOTIVE



301-3S Nozzle Only for #301S 5



302-3S Nozzle Only for #302S 5









303-3S Nozzle Only for #303S 5

SERVICE TOOLS

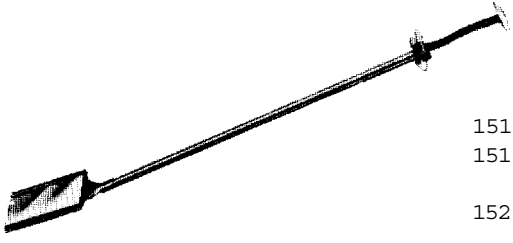
DISPLAYS

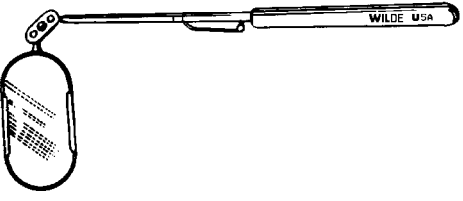
NOTE: All Nozzles are interchangeable with any of the above Blow Guns.

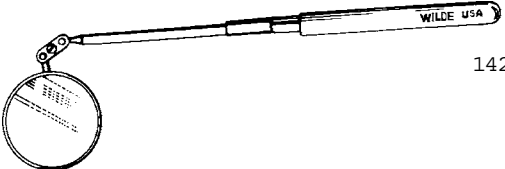
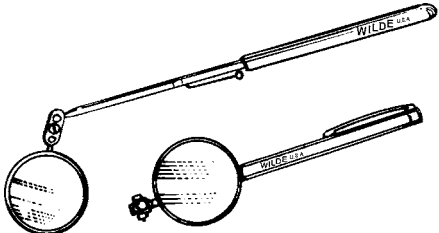
MIRRORS

	Cat. No.	Description	Std. Pk.	
	151	Tilting Inspection Mirror swings to angle desired by pressing plunger, locks at any angle & returns to straight position by tripping lock. Full 90° swing tilt. 16-1/2" Long, Rectangle Mirror 1-11/16" x 2-9/16".	5	Mirrors are not guaranteed.
	151P	#151 with unbreakable plastic mirror.	5	
	151-1	Replacement Glass for #151.	5	
	152	Tilting Inspection Mirror. Same as #151 except is 11" Long with a 1-1/4" x 1-1/2" Rectangular Mirror.	5	
	152-1	Replacement Glass for #152.	5	
	<hr/>			
	157	Inspection Mirror. Oval Shaped. Spring loaded ball socket adjustment. Spring pressure maintains adj. for any position on 360°. 8-1/2" Long, 1" x 2" Mirror.	5	
	<hr/>			
	157A	#157 with a Telescopic Handle. 4-1/2" Expands to 19-1/2".	5	
	157-1	Replacement Glass for #157.	5	
<hr/>				
	142	Inspection Mirror. Telescopic Handle 10" to 14" Length. 2-1/4" Dia. Mirror. Ball Joint Adjustment.	5	
	142-1	Replacement Glass for #142.	5	
<hr/>				
	143	Inspection Mirror. 8" Long, 1-1/4" Round Mirror, Ball Joint Adjustment.	5	
	143A	#143 with Telescopic Handle. Extends 4-1/2" to 18-1/2".	5	
	143-1	Replacement Glass for #143.	5	
	145	Plane Inspection Mirror. 7" Long, 7/8" Round Mirror, 135° Fixed Position, Vinyl Grip.	5	
<hr/>				
	147A	Telescopic Inspection Mirror, 4-1/2" to 18" Long, 7/8" Round Mirror. Double ball adj. head, pocket clip.	5	
	147A-1	Replacement Glass for #147A.	5	

PLIERS

PUNCHES, CHISELS & PRY BARS

WRENCHES

SCREWDRIVERS

PLUMBING & INDUSTRIAL

AUTOMOTIVE

SERVICE TOOLS

DISPLAYS



PICK UP TOOLS

PLIERS
PUNCHES, CHISELS & PRY BARS
WRENCHES
SCREWDRIVERS
PLUMBING & INDUSTRIAL
AUTOMOTIVE
SERVICE TOOLS
DISPLAYS

Cat. No. Description Std. Pk.

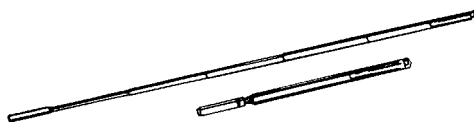

158A Magnetic Telescopic Pocket Pick Up Tool. Closed length 5-1/2", extends to 18-1/8". Handle & head made of Chrome plated Brass. Pocket Clip attached. 5



159A Magnetic Telescopic Pick Up Tool. Neodymium-Iron-Boron extra high flux magnet picks up to 1-1/2 lbs. Closed length 5-7/8", extends to 25-9/16". Pocket clip attached. 5

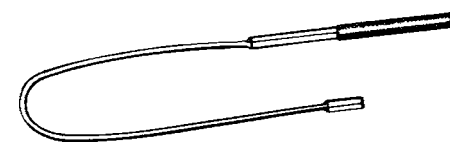

162V 21-1/2" Flexible Magnetic Pick Up Tool. Knurled Handle. Holds flex. Picks up ferrous metal to 1-1/2 lbs. 5

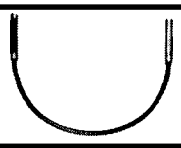

164V 17-1/2" Flexible Magnetic Pick Up Tool. Plastic gripped handle. 5



692 8-1/2" Magnetic Pick Up Tool. Hinged head contains powerful magnet. 12



694 27" Magnetic Pick Up Tool. Overall Length 27" extended, 16" closed. 12



792 Pocket Magnet Pick Up Tool. 6" Long. Pocket Clip attached. 12

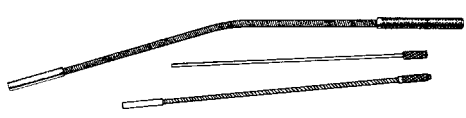

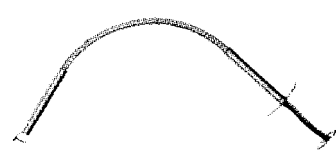

794 Flexible Magnetic Pick Up Tool. 18" Overall Length. Wire stiffening rod removable to make it completely flexible. 5/16" diameter. 12

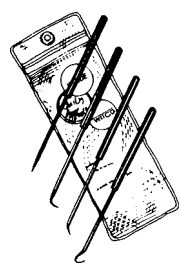

798 Flexible Mechanical Finger. Can be used as temporary clamp for small pieces. Can be bent into an "S" shape or at 90° without spring back. 15" reach. 8" flexible section. 2 Claws. 10

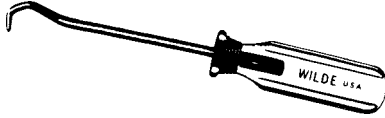
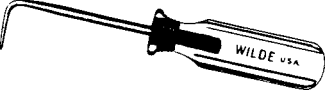
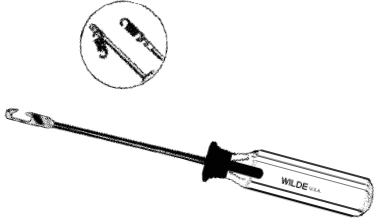

SHP904 4-Pc. Hook and Pick Set. 5

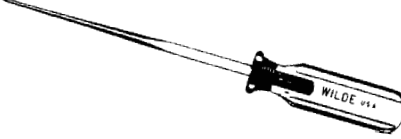
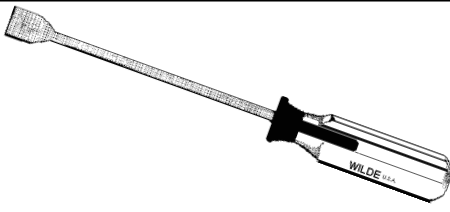
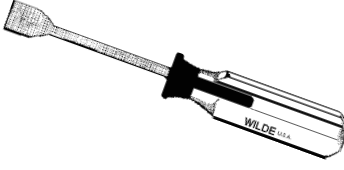
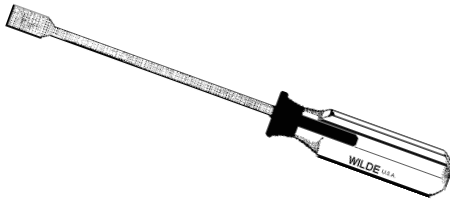
COTTER KEY EXTRACTORS		Cat.		Std.	
GASKET SCRAPERS & AWLS		No.	Description	Pk.	
	544	Cotter Key Extractor. 7" Long. Bits are forged alloy steel. Carded. "Insulite" plastic handle.	10	#'s 544, 566 & 545 series hooks/bit are not guaranteed.	
	544bit	Extra Hook for #544.	20		
	544-12	Cotter Key Extractor. 11" Long. Bits are forged alloy steel. Carded. "Insulite" plastic handle.	10		
	544-12bit	Extra Hook for #544-12B.	20		
	<hr/>				
	566	Radiator Hose Tool. Hook is made of hardened alloy steel. Carded. "Insulite" plastic handle. 7-1/4" Long.	10		
	566bit	Extra Hook for #566.	20		
<hr/>					
	545	8" Headlight Spring Tool. Punched end for removal and replacement. "Insulite" plastic handle.	10		
	<hr/>				
	421	11" Scratch Awl & Punch. 5/16" Bit. "Insulite" plastic handle.	10		
		442	7" Scratch Awl & Punch. 3/8" Bit. Extra heavy. "Insulite" handle.	10	
		451	5" Scratch Awl & Punch. 1/4" Bit. "Insulite" plastic handle.	10	
		452	7" Scratch Awl & Punch. 1/4" Bit. "Insulite" plastic handle.	10	
<hr/>					
	516	11" Gasket Scraper. 8" Exposed. 1" Face. Natural Finish bit. "Insulite" plastic handle. Carded.	10		
	516bit	Bit Only for #516.	50		
	516-5	8" Gasket Scraper. 5" Exposed. 1" Face. Natural Finish bit. "Insulite" plastic handle. Carded.	10		
	516bit	Bit Only for #516-5.	50		
	516-1/2	11" Gasket Scraper. 8" Exposed. 1/2" Face. Natural Finish bit. "Insulite" plastic handle. Carded.	10		
	516-1/2bit	Bit Only for #516-1/2.	50		

PLIERS

PUNCHES, CHISELS
& PRY BARS

WRENCHES

SCREWDRIVERS

PLUMBING &
INDUSTRIAL

AUTOMOTIVE

SERVICE TOOLS

DISPLAYS



SERVICE TOOLS

Cat. No. Description Std. Pk.

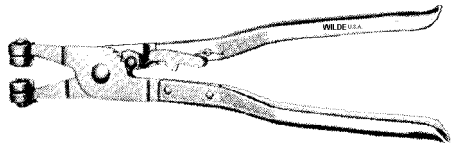

761 Hose Clamp Plier. For removing & installing spring wire hose clamps. Deep slots in jaws. Pawl automatically locks plier in any of three positions. Jaws swivel through 180°. Zinc plated. 10" Long. 5

PLIERS

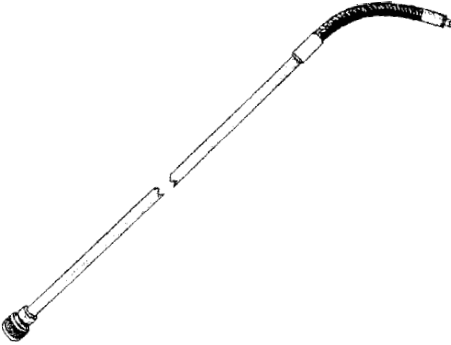

859 Flexible Driver Set contains one each of #854, 855, 856, 857 & 858. 5

PUNCHES, CHISELS & PRY BARS

WRENCHES

SCREWDRIVERS

PLUMBING & INDUSTRIAL

AUTOMOTIVE

SERVICE TOOLS

DISPLAYS

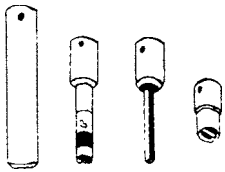

854 1/4" Drive Flexible Driver Only. 1/4" square drive to fit any 1/4" socket or attach. 21" Long, 3-1/2" Flexible section. 5

855 1/8" Hexagon Set Screw Wrench. Attachment for adjusting distributor points on GM cars. 2" Long. 5

856 Screw Driver Attachment for carburetor adjustment on most late model Ford, GM & Chrysler cars. 5

857 Screw Holding Attachment 5

858 1/2" - 1-5/8" Magnet Attachment 5



770 Contact Point File. Double cut file. High Grade steel tempered & finished. 5-1/4" Long. 10

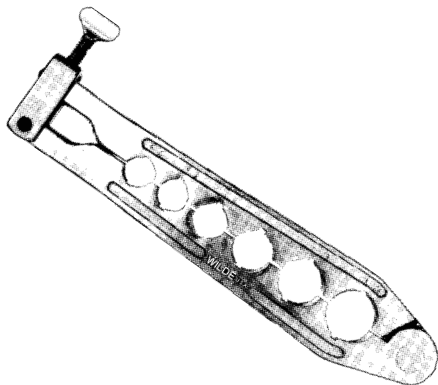

32 Axle Rethreading Die. Can be used without removing the axle from the housing. Split for quick application, is fitted to the threads at the back of the axle. Drop forged steel, heat treated. Nickel plated. Threads 3/4"-16, 3/4"-20, 7/8"-14, 1"-14, 1-1/8"-12, 1-1/4"-12. 1

#DB6

TOOL CENTER DISPLAY BOARD

**FREE TO THOSE CUSTOMERS WHO
ORDER \$750.00 OR MORE.
SIMPLY ORDER #DB6 AT NO CHARGE.**

ANY **WILDE® / WITCO®**
DISTRIBUTOR MAY PURCHASE AT
REGULAR DISTRIBUTOR PRICE.

HARD BLACK PLASTIC

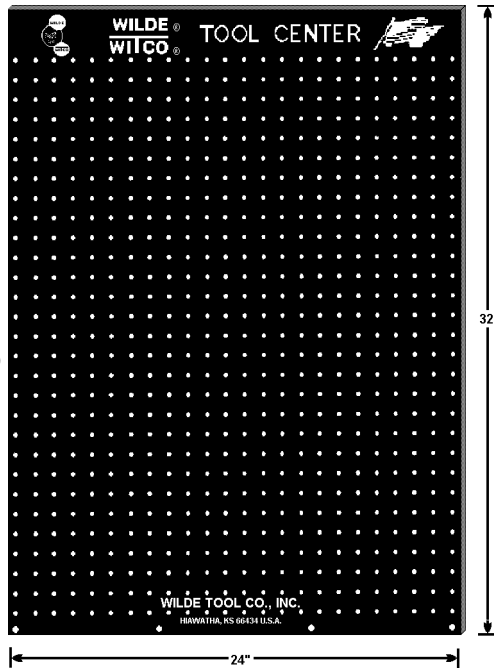

- MORE DURABLE
- 1" CENTERED HOLES
- WALL FASTENERS INCLUDED

MADE IN THE USA

ALSO

#DB5 TOOL CENTER

**FREE TO THOSE CUSTOMERS WHO
ORDER \$750.00 OR MORE.
SIMPLY ORDER #DB5 AT NO CHARGE.**

- Fits all standard pegboards.
- Holes punched every square inch.
- Pegboard ASSEMBLY CLIPS supplied for hanging board.
(pegboard hooks NOT supplied)
- Order only the tools you want.

(while supply lasts)

FLEXIBLE VINYL

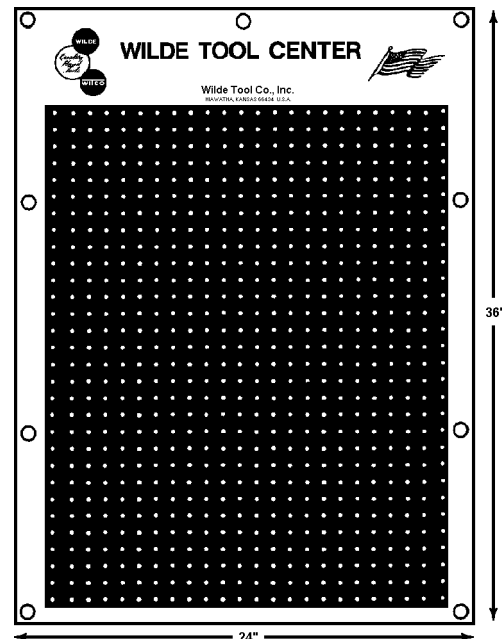

MADE IN THE USA

PLIERS

PUNCHES, CHISELS
& PRY BARS

WRENCHES

SCREWDRIVERS

PLUMBING &
INDUSTRIAL

AUTOMOTIVE

SERVICE TOOLS

DISPLAYS





Wilde Tool Co., Inc.
HIAWATHA, KANSAS 66434 U.S.A.

**Pipe
Wrench
Plier**

WILDE U.S.A.

WILDE U.S.A.

WILDE U.S.A.

WITCO U.S.A.

WITCO U.S.A.

WITCO U.S.A.

Wilde Tool Co., Inc.
HIAWATHA, KANSAS 66434 U.S.A.

Wilde Tool Co., Inc.
HIAWATHA, KANSAS 66434 U.S.A.



REFERENCE DATA (Decimal and Metric Equivalent of Fractions)

	Decimal	Metric		Decimal	Metric
	$\frac{1}{64}$ — .0156	0.397		$\frac{33}{64}$ — .5156	13.097
$\frac{1}{32}$	$\frac{1}{32}$ — .0313	.0794	$\frac{17}{32}$	$\frac{35}{64}$ — .5469	13.891
	$\frac{3}{64}$ — .0469	1.191		$\frac{37}{64}$ — .5781	14.684
$\frac{1}{16}$	$\frac{5}{64}$ — .0781	1.984	$\frac{9}{16}$	$\frac{39}{64}$ — .6094	15.478
	$\frac{7}{64}$ — .1094	2.381		$\frac{41}{64}$ — .6406	16.272
$\frac{1}{8}$	$\frac{9}{64}$ — .1406	3.572	$\frac{5}{8}$	$\frac{43}{64}$ — .6719	17.066
	$\frac{11}{64}$ — .1719	4.366		$\frac{45}{64}$ — .7031	17.859
$\frac{3}{16}$	$\frac{13}{64}$ — .2031	5.159	$\frac{11}{16}$	$\frac{47}{64}$ — .7344	18.653
	$\frac{15}{64}$ — .2344	5.953		$\frac{49}{64}$ — .7656	19.447
$\frac{1}{4}$	$\frac{17}{64}$ — .2656	6.747	$\frac{3}{4}$	$\frac{51}{64}$ — .7969	20.241
	$\frac{19}{64}$ — .2969	7.541		$\frac{53}{64}$ — .8281	21.034
$\frac{5}{16}$	$\frac{21}{64}$ — .3281	8.334	$\frac{13}{16}$	$\frac{55}{64}$ — .8594	21.828
	$\frac{23}{64}$ — .3594	9.128		$\frac{57}{64}$ — .8906	22.822
$\frac{3}{8}$	$\frac{25}{64}$ — .3906	9.922	$\frac{7}{8}$	$\frac{59}{64}$ — .9219	23.416
	$\frac{27}{64}$ — .4219	10.716		$\frac{61}{64}$ — .9531	24.209
$\frac{7}{16}$	$\frac{29}{64}$ — .4531	11.509	$\frac{15}{16}$	$\frac{63}{64}$ — .9844	25.003
	$\frac{31}{64}$ — .4844	12.303			
$\frac{1}{2}$	$\frac{31}{64}$ — .4844	12.303	$\frac{1}{2}$		



ORDER FORM

BUY AMERICAN  BY AMERICANS

YES, enter my order no.

BILL TO:

SHIP TO:

_____ : Company Name : _____
 _____ : Address : _____
 _____ : P.O. Box : _____
 _____ : City/State/Zip : _____

Special Instructions:

Ship Date: _____

Telephone #: _____

Email: _____

Fax #: _____

Person Placing Order: _____

NEW CUSTOMERS - PLEASE FORWARD TAX RESALE NUMBER AND THREE NATIONAL CREDIT REFERENCES

WE CANNOT SELL UNLESS PURCHASED FOR RESALE

QUANTITY	CAT. NO.	DESCRIPTION	PRICE EA.	TOTAL PRICE

WILDE TOOL CO., INC.

13TH & POTTAWATOMIE STREETS • P.O. BOX 30
 HIAWATHA, KS 66434 • (785) 742-7171
 FAX #: (785) 742-3719

Dear Wilde/Witco Customer:

We appreciate your interest in our quality hand tool line. To serve your needs this form is for your use in ordering additional literature, **FREE OF CHARGE.**



Quantity Item

_____ Wilde's current Distributor Price List. (We cannot ship if we do not have your resale tax number.)
(Current Distributors - Disregard.) # _____

_____ Wilde's current List Price List.

_____ Wilde's No-Price Catalog.

WILDE® U.S.A.

- Sales Brochure and Re-Order Form for sales literature.
- Please have your inside sales person telephone me.
- Please have your local sales representative call on me.
- Please forward me a list of Wilde Distributors in my area.

WITCO® U.S.A.



Company: _____ Street Zip (If Different)

Street Address: _____

P.O. Box: _____

City/State/Zip: _____

Attn: _____ email: _____

Telephone: () _____ Fax: () _____

Wilde Tool Co., Inc.

HIAWATHA, KANSAS 66434 U.S.A.

C/LR1 6-2001

Dear Wilde/Witco Customer:

We appreciate your interest in our quality hand tool line. To serve your needs this form is for your use in ordering additional literature, **FREE OF CHARGE.**



Quantity Item

_____ Wilde's current Distributor Price List. (We cannot ship if we do not have your resale tax number.)
(Current Distributors - Disregard.) # _____

_____ Wilde's current List Price List.

_____ Wilde's No-Price Catalog.

WILDE® U.S.A.

- Sales Brochure and Re-Order Form for sales literature.
- Please have your inside sales person telephone me.
- Please have your local sales representative call on me.
- Please forward me a list of Wilde Distributors in my area.

WITCO® U.S.A.



Company: _____ Street Zip (If Different)

Street Address: _____

P.O. Box: _____

City/State/Zip: _____

Attn: _____ email: _____

Telephone: () _____ Fax: () _____

Wilde Tool Co., Inc.

HIAWATHA, KANSAS 66434 U.S.A.

C/LR1 6-2001

NOTES

NUMERICAL INDEX

Cat. No.	Pg. No.	Cat. No.	Pg. No.	Cat. No.	Pg. No.	Cat. No.	Pg. No.	Cat. No.	Pg. No.
53216	32	CCL3232-18B	18	G292SPB	13	PC1632B	21	PS1032B	21
53217	32	CD432	18	G292SPD	13	PC2032	21	PS1232	21
53218	32	CD432B	18	G293P-NP	5	PC2032B	21	PS1232B	21
53219	32	CD532	18	G293B	5	PLT5	23	PW8	49
53307	32	CD532B	18	G295P-NP	5	PLT232	20	PW10	49
53308	32	CD632	18	G295B	5	PLT232B	20	PW14	49
53309	32	CD632B	18	G297P-NP	5	PLT332	20	PW18	49
53310	32	CD832	18	G297B	5	PLT332B	20	PW24	49
53311	32	CD832B	18	G297SP	13	PLT432	20	PW36	49
53312	32	CD1032	18	G299P-NP	5	PLT432B	20	RB2432	19
53313	32	CD1032B	18	G299B	5	PLT532	20	RB2432B	19
53314	32	CD1232	18	G299SP	13	PLT532B	20	RHL232-9	22
53315	32	CD1232B	18	G404P-NP	11	PLT632	20	RHL232-9B	22
53316	32	CD1632	18	G404B	11	PLT632B	20	RHL632-12	22
53317	32	CD1632B	18	G410P-NP	10	PLT732	20	RHL632-12B	22
53318	32	CD2032	18	G410B	10	PLT732B	20	RHL632	22
53319	32	CD2032B	18	G428N-NP	8	PLT832	20	RHL632B	22
902131	31	CP632	19	G704P-NP	11	PLT832B	20	RH2032	22
902136	31	CP632B	19	G704B	11	PLT932	20	RH2032B	22
902141	33	CP732	19	G705B	11	PLT932B	20	RS232	25
903121	30	CP732B	19	HPB1232-7B	22	PLT1032	20	RS564	25
903129	30	CP832	19	HPB1232-12B	22	PLT1032B	20	RS332	25
903141	33	CP832B	19	HPB1632-18B	22	PLT1232	20	RS432	25
904131	31	CP1032	19	HPB1632-24B	22	PLT1232B	20	RS532	25
907133X	32	CP1032B	19	HPB2032-28B	22	PP5	23	RS632	25
908132	31	CP1232	19	HPB3B	22	PP232	20	RS732	25
909122	30	CP1232B	19	JB1632	22	PP232B	20	RS832	25
909124	30	CR432	19	JB1632B	22	PP564	20	RS1032	25
909134	32	CR432B	19	JB2032	22	PP564B	20	RS1232	25
909135	32	CR632	19	JB2032B	22	PP332	20	RS1432	25
909522	30	CR632B	19	JB2432	22	PP332B	20	RS1632	25
911133	31	CR732	19	JB2432B	22	PP432	20	RS906	25
913532	32	CR732B	19	JB2432-24	22	PP432B	20	RS912	25
913533	32	CR832	19	JB2432-24B	22	PP532	20	S14	42
915143	33	CR832B	19	JB2832	22	PP532B	20	S22	42
A67	12	CR1032	19	JB2832B	22	PP632	20	S25	42
AWB4	40	CR1032B	19	K5	24	PP632B	20	S42	42
AWB6	40	CR1232	19	K8	24	PP732	20	S43	42
AWB8	40	CR1232B	19	K12	24	PP732B	20	S44	42
AWB10	40	CR1632	19	K20	24	PP832	20	S46	42
AWB12	40	CR1632B	19	LB632	21	PP832B	20	S64	42
AWB15	40	DB5	73	LB632B	21	PP1032	20	S83	42
AWB18	40	DB6	73	LB732	21	PP1032B	20	S85	42
AWB24	40	G6	24	LB732B	21	PP1232	20	S86	42
AWC4	40	G6N	8	LB832	21	PP1232B	20	S104	42
AWC6	40	G8N	8	LB832B	21	PPL4	23	S126	42
AWC8	40	G250P-NP	6	LB1032	21	PPL432	20	SHP904	70
AWC10	40	G250B	6	LB1032B	21	PPL432B	20	SMC6	34
AWC12	40	G251P-NP	6	MC10	34	PPL532	20	SMC6B	34
AWC15	40	G251B	6	MC11	34	PPL532B	20	SMC10	34
AWC18	40	G252P-NP	6	MC12	34	PPL632	20	SMC10B	34
AWC24	40	G252B	6	MC13	34	PPL632B	20	SMD910	44
CC5	23	G253P-NP	6	MC14	34	PPL732	20	SW2	43
CC9	23	G253B	6	MC15	34	PPL732B	20	SW2-1S	43
CC832	18	G254P-NP	6	MC16	34	PPL832	20	SW2-2L	43
CC832B	18	G254B	6	MC17	34	PPL832B	20	SW4	43
CC1032	18	G256SPD	12	MC18	34	PPL1032	20	SW4-1S	43
CC1032B	18	G258SPD	12	MC19	34	PPL1032B	20	SW4-2L	43
CC1232	18	G259SPD	12	MD4	44	PPL132B	20	SW4-T15	43
CC1232B	18	G260P-NP	7	MD45	44	PPL1232B	20	SW4-T25	43
CC1432	18	G260B	7	MD5	44	PR832	21	SW4-R	43
CC1432B	18	G261BP-NP	7	MD55	44	PR832B	21	SW7	43
CC1632	18	G261BB	7	MD6	44	PR1032	21	SW7-1	43
CC1632B	18	G261TP-NP	7	MD7	44	PR1032B	21	SW7-2	43
CC2032	18	G261TB	7	MD8	44	PR1632	21	SW7-3	43
CC2032B	18	G262P-NP	7	MD9	44	PR1632B	21	SW7-4	43
CC2432	18	G262B	7	MD10	44	PR1232	21	SW7-5	43
CC2432B	18	G262P-NP	7	MD11	44	PR1232B	21	SW7-6	43
CC2832	18	G263P-NP	7	P142	42	PR1632	21	SW7-7	43
CC2832B	18	G263B	7	P220	42	PR1632B	21	SW8	43
CC3232	18	G264P-NP	7	P331	42	PS232	21	SW9	43
CC3232B	18	G264B	7	P442	42	PS232B	21	SW10	43
CC3632	18	G269P-NP	4	P653	42	PS332	21	T10	45
CC3632B	18	G269B	4	PB2032	22	PS332B	21	T15	45
CC4	23	G270P-NP	4	PB2032B	22	PS432	21	T20	45
CCL1632	18	G270B	4	PB2432	22	PS432B	21	T25	45
CCL1632B	18	G271P-NP	4	PB2432B	22	PS532	21	T27	45
CCL2032	18	G271B	4	PC832	21	PS532B	21	T30	45
CCL2032B	18	G272P-NP	4	PC832B	21	PS632	21	TS35	45
CCL2432	18	G272B	4	PC1032	21	PS632B	21	3CPG	
CCL2432B	18	G274P-NP	4	PC1032B	21	PS732	21	8DFG	
CCL2432-14	18	G274B	4	PC1232	21	PS732B	21	10DFG	
CCL2432-14B	18	G276P-NP	4	PC1232B	21	PS832	21	12DFG	
CCL2432-18	18	G276B	4	PC1632	21	PS832B	21		
CCL2832	18								
CCL2832B	18								
CCL3232	18								
CCL3232B	18								
CCL3232-18	18								