

ATP

Super Duty Industrial
Pneumatic Tools and
Replacement Parts

OZAT

Super Strength Impact
Sockets, Striking Wrenches
and Accessories

Shors

®
Legendary Construction
Air Tools Since 1886



ATP

Air Tools
Parts and
Accessories



ATP

A Division of Hy-Tech Machine

25 Leonberg Road
Cranberry Township, PA 16066
1-800-245-1148
Fax: 724-776-0227

About Us

Hy-Tech Machine has been in business since 1923 and is a proud American company that manufactures super duty industrial pneumatic tools and replacement parts for the toughest applications. Our tools and parts serve demanding domestic and international markets. We offer these products under the names of ATP, Thor, Arnessen, Eureka, Thaxton and Ozat.

Located in Cranberry Township, PA – USA, our highly talented and trained employees have the skill and Hy-Tech Machine management provides the resources to produce the highest quality tools and replacement parts found anywhere in the world today. Our replacement parts offer an alternative to the OEM for many of the recognized tool manufacturers such as Ingersoll-Rand, Chicago Pneumatic, Cleco, Top Cat and others. Our management team has learned the business on the shop floor. They understand quality standards and will not compromise on these standards. Just ask any of our customers or distributors that declare our products to be equal to or better than the OEM. This fact is backed by our lifetime warranty on replacement parts and Ozat sockets against defects in workmanship and material.

Hy-Tech Machine is capable of handling large volume production but we can also custom make tools and parts, even if the quantity is one. This flexibility gives us that unique ability that many corporate tool manufacturers lack today.

The markets we serve have demanding schedules where downtime is not an option. Customers know to come to us first for quick delivery from our broad stock of inventory and willingness to do what it takes to get them back in production.

American made, unsurpassed quality, competitive pricing, fast delivery and outstanding service is what we have to offer. If you currently are a customer, Thank You. If you are looking for an alternative to domestic or imported tools and parts at a value added price, give us a chance to prove to you why we are the right company for your tooling and replacement parts needs.

ATP's extended line of products

ATP offers a complete line of Air Tools made to compete in today's "World Market". Just as we've become your source for air tool solutions, you can count on ATP for quality Air Tools shipped the same day.

Our ATP Advantage is Hy-Tech Machine

ATP's parent company Hy-Tech Machine uses state-of-the-art machining equipment to guarantee precision in ATP products. Rigid specifications are constantly maintained. Quality control is stringently monitored and custom machining requests are not a problem at ATP.

- A name known for quality
- Respected across the industry
- Product standards second to none
- Tool knowledge from hands on experience
- Over 10,000 OEM part numbers in stock
- Computerized data base

Courteous, knowledgeable answers to your questions are part of the story. Our people are a tightly knit group who have worked together for years, we're like a family and we're proud of that. You can use any of ATP's products with confidence.

www.onlineatp.com

ATP

A Division of Hy-Tech Machine

Contents



Impact Tools 2

Super Duty 3/4", 1", 1-1/2", 2-1/2", 3-1/2"
#4 & 5 Spline, Extended Anvil, Right Angle
UNA-DRIV, Specialty, Zamac



Abrasive Tools 9

Die Grinders & Angle Grinders
Vertical & Horizontal Grinder Series

Percussive Tools 14

Scalers & Hammers



Thor Construction Tools 17

Breakers, Diggers, Rivet Buster,
Backfill Tampers, Concrete Scabblers

Centrifugal Sump Pump 21

Air Hoists 22

Air Drills 23

Air Motors 24



Air Movers 25

Jet Air, Venturi "Air Horns"



Rail Car Gate Openers 27

Air Tool Accessories 28

Blue Majic & Pure Gold (Lubricants)
Lubricators (Oilers), Couplings
Replacement Parts
Tune-up Kits



Ozat Sockets 33

1/2 Inch Square Drive, 5/8 Inch Square
Drive, 3/4 Inch Square Drive, 1 Inch Square
Drive, 1-1/2 Inch Square Drive, 2-1/2 Inch
Square Drive, 3-1/2 Inch Square Drive,
#5 Spline Drive, Flat Striking Wrenches,
Offset Striking Wrenches, Striking wrench
Adapters, Strike Force Safety Wrenches,
Torque Multipliers,



The World's Most Extensive Line of Super Duty Impact Tools

An impact tool uses a relatively low torque motor which supplies rotary inertia to a special clutch mechanism. The mechanism converts this inertia into a series of impact blows which gradually build up torque in the fastener.

The effect is similar to torque obtained when a hand wrench is placed on a nut and the opposite end is struck with a hammer. The torque reaction is not transmitted back to the operator. Therefore, fasteners can be safely tightened to high torques with impact tools. The maximum torque is determined by the size of the impact tool, the air pressure and the length of time the tool is on the fastener.

ATP Impact Tools feature alloy steel hammer cases that are machined from solid bar stock, not drawn or cast utilized by some manufacturers. ATP's current product standards meet or exceed those of any tool or parts manufacturer in the marketplace. We do not compromise quality. First, ATP Tools and Replacement parts are made to last.

Impact Tool Applications

Applications for these impacts include refineries, petrochemical plants, power generation plants, railroads, paper mills, heavy off-road equipment repair, foundries, mining, steel mills, steel fabrication, bridge work and are a popular choice for steel erection.

ATP Mechanism / Clutch Basics

Twin Hammer:

Two hammers strike balance blows for more torque per pound than any competitive tool. This simplified design with inertia engaged reversible hammers means easy, low cost maintenance. Good performance on both hard and soft joint applications, also less sensitive to air pressure changes than any other design.

Single "Jumbo" Hammer:

The single hammer mechanism performs similarly to the Twin Hammer, but uses a single hammer in operation.

Ball and Cam:

Precision ball and cam mechanism converts air motor torque into powerful rotary impacts . . . a time tested design for maximum durability, ideal for soft joint applications. Utilized in very large impact tools.

Two Jaw:

High energy per blow for maximum performance. High ultimate torque, highest power to weight ratio. Excellent choice for those tough MRO and assembly applications. Good on soft pull up joints, excellent on hard joint pull up joints.

Twin Lobe:

All around clutch with high ultimate torque and high power to weight ratio.

Three Jaw:

Very good all around high output clutch. Good on either hard or soft pull up applications, high ultimate torque.

Rocking Dog:

Long life clutch. Good for hard or soft pull-up applications. Fast run down of free running fasteners.

PT = Pistol Grip/Trigger
EI = End Grip/Inside Trigger
EO = End Grip/Outside Trigger
LT = Lever Throttle

TH = Through Hole
5S = 5 Spline
RR = Ring Retainer
1H = 1" Sq. Through Hole

Example:

ATP 7560 PT-TH is a 3/4 Inch Drive Pistol Grip Tool With A Through Hole Anvil.

Lever Throttle

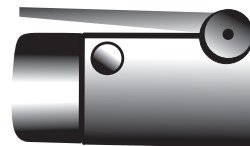

End Grip
Outside Trigger



Pistol Grip

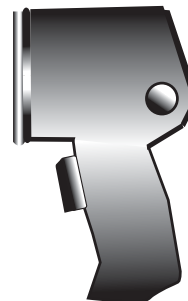

End Grip
Inside Trigger



Spline Drive



Square Drive

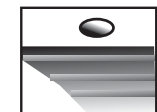

Where Referenced:

CP is a registered trademark of Chicago Pneumatic

IR is a registered trademark of Ingersoll Rand

Cleco is a registered trademark of Apex Tool Group

Super Duty 3/4" Class Impact Tools

Available with 1" and #4 Spline Drives



ATP 2059 PT-TH



ATP 7506 EO-TH



ATP 7520 PT-1H



ATP 7525 PT-TH



ATP 7560 PT-TH

5/8" - 3/4" Bolt Capacity (16mm - 19mm)

MODEL#	Working Torque FT LB (NM)	Max Torque FT LB (NM)	Handle Type	Drive Size	Socket Retainer	Length Inches	Weight Lbs.	Hose Size	Equivalent To
ATP 7506EO-4S	390 (530)	650 (881)	End Grip O-T	#4 Spline	Button	8.75"	12	1/2"	CP0606-GASAL
ATP 7506EO-TH	390 (530)	650 (881)	End Grip O-T	3/4" Sq.	Through Hole	11.5"	12.75	1/2"	CP0606-GASAB
ATP 7560PT-1H	575 (780)	1025 (1898)	Pistol Grip	1" Sq.	Through Hole	7.6"	11.7	1/2"	CP6060-SASAK
ATP 7560PT-4S	575 (780)	1025 (1898)	Pistol Grip	#4 Spline	Button	7.6"	11.7	1/2"	CP6060-SASAL
ATP 7560PT-TH	560 (760)	1000 (1356)	Pistol Grip	3/4" Sq.	Through Hole	7.6"	11.6	1/2"	CP6060-SASAB
ATP 7560PT-RR	560 (760)	1000 (1356)	Pistol Grip	3/4" Sq.	Ring Retainer	7.6"	11.6	1/2"	CP6060-SASAR
ATP 7520PT-TH	800 (1085)	1100 (1491)	Pistol Grip	3/4" Sq.	Through Hole	12.5"	12	1/2"	IR2920P1
ATP 7520PT-1H*	800 (1085)	1100 (1491)	Pistol Grip	1" Sq.	Through Hole	12.5"	12	1/2"	IR2920P3
ATP 7525PT-TH	1100 (1492)	1450 (1966)	Pistol Grip	3/4" Sq.	Through Hole	8.9"	12.5	1/2"	IR2925P1Ti
ATP 7525RB-TH*	1400 (1898)	1600 (2169) rev	Pistol Grip	3/4" Sq.	Through Hole	8.9"	12.5	1/2"	IR2925RBP1Ti
ATP 7525PT-4S	1100 (1492)	1450 (1966)	Pistol Grip	#4 Spline	Button	8.9"	12.5	1/2"	IR2925P/#4Spline
ATP 7525PT-1H	1100 (1492)	1450 (1966)	Pistol Grip	1" Sq.	Through Hole	8.9"	12.5	1/2"	IR2925P3Ti
ATP 7525RB-1H*	1400 (1898)	1600 (2169) rev	Pistol Grip	1" Sq.	Through Hole	8.9"	12.5	1/2"	IR2925RBP3Ti
ATP 2059PT-TH*	700 (949)	1200 (1600) rev	Pistol Grip	3/4" Sq.	Through Hole	7.8"	12	1/2"	Cleco WP-2059-6
ATP 2060PT-TH	700 (949)	1200 (1600)	Pistol Grip	3/4" Sq.	Through Hole	7.8"	12	1/2"	Cleco WP-2060B-6
ATP 2059PT-1H*	800 (1085)	1200 (1600) rev	Pistol Grip	1" Sq.	Through Hole	7.8"	12.1	1/2"	Cleco WP-2059-8
ATP 2060PT-1H	900 (1220)	1200 (1600)	Pistol Grip	1" Sq.	Through Hole	7.8"	12.1	1/2"	Cleco WP-2060-8

*Reverse Bias Power Models. All models available with extended anvil. Contact ATP Customer Service for more information. See Ozat Sockets starting on page 33. Ret ring information is provided for every socket in OZAT section.

Super Duty 1" Drive Class Impact Tools

Available with #5 Spline Drive

ATP 1010 EO-TH



ATP 1011 PT-TH



ATP 16110 EI-TH



ATP 2109 EI-1H



ATP 1010 Series

The ATP 1010 is a super duty tool for high volume, heavy production.

- Three Jaw Clutch
- Excellent for soft joints; Ex. Thick gasketed applications
- Three piece housing design
- Oil lubricated for long life



ATP 1011 Series

A real work horse of a tool for construction, maintenance, super duty production and repair work.

- Two Jaw Clutch transfers power efficiently
- Three piece housing design
- Steel Clutch Housing Design
- Great power to weight ratio

ATP 1012 Series

- Super duty power
- Steel Hammer Case
- Single Jumbo Hammer Mechanism

ATP 2109 & 2110 Series

- Three piece housing for easy repair
- Through bolt construction eliminates stripped housings
- Steel clutch hammer case for strength and durability
- Smooth impact mechanism provides increased power
- 2109 Models reverse bias power

1" - 1-3/8" Bolt Capacity (25mm - 35mm)

MODEL#	Working Torque FT LB (NM)	Max Torque FT LB (NM)	Handle Type	Drive Size	Socket Retainer	Length Inches	Weight Lbs.	Hose Size	Equivalent To
ATP 1010EI-TH	950 (1288)	1350 (1830)	End Grip I-T	1" Sq.	Through Hole	13.5"	20.5	3/4"	CP0610-PALED
ATP 1010EO-TH	950 (1288)	1350 (1830)	End Grip O-T	1" Sq.	Through Hole	13.5"	20.5	3/4"	CP0610-GALED
ATP 1010EO-5S	950 (1288)	1350 (1830)	End Grip O-T	#5 Spline	Button	13.5"	20.5	3/4"	CP0610-GALEL
ATP 1011PT-TH	1800 (2440)	2800 (3796)	Pistol Grip	1" Sq.	Through Hole	10.7"	23.1	3/4"	CP0611-PRS
ATP 1011PT-5S	1800 (2440)	2800 (3796)	Pistol Grip	#5 Spline	Button	10.7"	23.1	3/4"	CP0611
ATP 1011EI-TH	1800 (2440)	2800 (3796)	End Grip I-T	1" Sq.	Through Hole	12.5"	22.5	3/4"	CP0611-PASED
ATP 1011EO-TH	1800 (2440)	2800 (3796)	End Grip O-T	1" Sq.	Through Hole	12.5"	22.5	3/4"	CP0611-GASED
ATP 1011EI-5S	1800 (2440)	2800 (3796)	End Grip I-T	#5 Spline	Button	12.5"	22.5	3/4"	CP0611-PASEL
ATP 1011EO-5S	1800 (2440)	2800 (3796)	End Grip O-T	#5 Spline	Button	12.5"	22.5	3/4"	CP0611-GASEL
ATP 16110EI-1H	1250 (1685)	1900 (2575)	End Grip I-T	1"	Through Hole	13"	21.5	3/4"	CP6110-PASED
ATP 16110EI-5S	1250 (1685)	1900 (2575)	End Grip I-T	#5 Spline	Button	13"	21.5	3/4"	CP6110-PASEL
ATP 2109PT-1H*	1650 (2250)	2500 (3400) rev	Pistol Grip	1" Sq.	Through Hole	9.5"	20.75	3/4"	Cleco WP-2109B-8
ATP 2109PT-5S*	1800 (2440)	2500 (3400) rev	Pistol Grip	#5 Spline	Button	9.75"	21.25	3/4"	Cleco WPS-2109B
ATP 2109EI-1H*	1650 (2250)	2500 (3400) rev	End Grip I-T	1" Sq.	Through Hole	12.88"	21	3/4"	Cleco WT-2109-8
ATP 2109EI-5S*	1800 (2440)	2500 (3400) rev	End Grip I-T	#5 Spline	Button	13.12"	21.5	3/4"	Cleco WTS-2109
ATP 2110PT-1H	1650 (2250)	2500 (3400)	Pistol Grip	1" Sq.	Through Hole	9.5"	20.75	3/4"	Cleco WP-2110B-8
ATP 2110PT-5S	2000 (2711)	2500 (3400)	Pistol Grip	#5 Spline	Button	9.75"	21.25	3/4"	Cleco WPS-2110B
ATP 2110EI-1H	1650 (2250)	2500 (3400)	End Grip I-T	1" Sq.	Through Hole	12.88"	21	3/4"	Cleco WT-2110-8
ATP 2110EI-5S	2000 (2711)	2500 (3400)	End Grip I-T	#5 Spline	Button	14.3"	27.6	3/4"	Cleco WTS-2120

*Reverse Bias Power Models. All models available with extended anvil. Contact ATP Customer Service for more information. See Ozat Sockets starting on page 33. Ret ring information is provided for every socket in OZAT section.

Super Duty 1" Drive Class Impact Tools

Available with #5 Spline Drive



ATP 1042 PT-TH



ATP 1034EI-THB9



ATP 1040 EI-TH

ATP 1034 & 1040 Series

- Super Duty Impact for demanding applications
- Twin Hammer Impact Mechanism
- Bronze Endplates for Long Life
- Integral Muffler for low noise
- Steel Hammer Case Housing



ATP 1041 & 1042 Series

- Super Duty Impact for demanding applications
- 7-Vane Motor provides Awesome power to weight ratio
- Twin Hammer Impact Mechanism
- Bronze Endplates for Long Life
- Integral Muffler for low noise
- Available in Pistol Grip or End Handle

1" - 1-3/8" Bolt Capacity (25mm - 35mm)

MODEL#	Working Torque FT LB (NM)	Max Torque FT LB (NM)	Handle Type	Drive Size	Socket Retainer	Length Inches	Weight Lbs.	Hose Size	Equivalent To
ATP 1012EI-TH	1000 (1356)	1350 (1830)	End Grip I-T	1" Sq.	Through Hole	11.5"	19	3/4"	IR1712B2
ATP 1012EO-TH	1000 (1356)	1350 (1830)	End Grip O-T	1" Sq.	Through Hole	11.5"	19	3/4"	IR1712A2
ATP 1017EI-TH	1000 (1356)	1600 (2169)	End Grip I-T	1" Sq.	Through Hole	11.25"	18.25	3/4"	IR280
ATP 1017EO-TH	1000 (1356)	1600 (2169)	End Grip O-T	1" Sq.	Through Hole	11.25"	18.25	3/4"	IR280
ATP 1017EI-5S	1000 (1356)	1600 (2169)	End Grip I-T	#5 Spline	Button	11.25"	18.25	3/4"	IR1734B1
ATP 1017EO-5S	1000 (1356)	1600 (2169)	End Grip O-T	#5 Spline	Button	11.25"	18.25	3/4"	IR1734A1
ATP 1034EI-TH	1100 (1491)	1500 (2034)	End Grip I-T	1" Sq.	Through Hole	11.25"	19	3/4"	IR2934B2
ATP 1034EO-TH	1100 (1491)	1500 (2034)	End Grip O-T	1" Sq.	Through Hole	11.25"	19	3/4"	IR2934A2
ATP 1034EI-5S	1100 (1491)	1500 (2034)	End Grip I-T	#5 Spline	Button	11.25"	19	3/4"	IR2934B1
ATP 1034EO-5S	1100 (1491)	1500 (2034)	End Grip O-T	#5 Spline	Button	11.25"	19	3/4"	IR2934A1
ATP 1034EI-THB9	500 (678)	750 (1000)	End Grip I-T	1" Sq.	Through Hole	18.75"	35.7	3/4"	IR2934B9
ATP 1040PT-TH	1600 (2169)	2000 (2711)	Pistol Grip	1" Sq.	Through Hole	9.88"	24	3/4"	IR2940P2
ATP 1040PT-5S	1600 (2169)	2000 (2711)	Pistol Grip	#5 Spline	Button	9.88"	24	3/4"	IR2940P1
ATP 1040EI-TH	1600 (2169)	2000 (2711)	End Grip I-T	1" Sq.	Through Hole	12.4"	24	3/4"	IR2940B2
ATP 1040EO-TH	1600 (2169)	2000 (2711)	End Grip O-T	1" Sq.	Through Hole	12.4"	24	3/4"	IR2940A2
ATP 1040EI-5S	1600 (2169)	2000 (2711)	End Grip I-T	#5 Spline	Button	12.4"	24	3/4"	IR2940B1
ATP 1040EO-5S	1600 (2169)	2000 (2711)	End Grip O-T	#5 Spline	Button	12.4"	24	3/4"	IR2940A1
ATP 1041EO-5S	1650 (2240)	2500 (3390)	End Grip O-T	#5 Spline	Button	11.25"	19	3/4"	IR3940A1Ti
ATP 1041EO-TH	1650 (2240)	2500 (3390)	End Grip O-T	1" Sq.	Through Hole	11.25"	19	3/4"	IR3940A2Ti
ATP 1041EI-5S	1650 (2240)	2500 (3390)	End Grip I-T	#5 Spline	Button	11.25"	19	3/4"	IR3940B1Ti
ATP 1041EI-TH	1650 (2240)	2500 (3390)	End Grip I-T	1" Sq.	Through Hole	11.25"	19	3/4"	IR3940B2Ti
ATP 1041PT-TH	1650 (2240)	2500 (3390)	Pistol Grip	1" Sq.	Through Hole	8.65"	20	3/4"	IR3940P2Ti
ATP 1042PT-TH	1900 (2576)	3200 (4338)	Pistol Grip	1" Sq.	Through Hole	9.88"	24.6	3/4"	IR3942P2Ti
ATP 1042PT-5S	1900 (2576)	3200 (4338)	Pistol Grip	#5 Spline	Button	9.88"	24.6	3/4"	IR3942P1Ti
ATP 1042EI-TH	1900 (2576)	3200 (4338)	End Grip I-T	1" Sq.	Through Hole	12.4"	24.2	3/4"	IR3942B2Ti
ATP 1042EO-TH	1900 (2576)	3200 (4338)	End Grip O-T	1" Sq.	Through Hole	12.4"	24.2	3/4"	IR3942A2Ti
ATP 1042EI-5S	1900 (2576)	3200 (4338)	End Grip I-T	#5 Spline	Button	12.4"	24.2	3/4"	IR3942B1Ti
ATP 1042EO-5S	1900 (2576)	3200 (4338)	End Grip O-T	#5 Spline	Button	12.4"	24.2	3/4"	IR3942A1Ti

All models available with extended anvil. Contact ATP Customer Service for more information.
See Ozat Sockets starting on page 33. Ret ring information is provided for every socket in OZAT section.

Super Duty 1-1/2" Drive Class Impact Tools

Available with Square Drives and #5 Spline Drive



ATP 1514EO-TH

ATP 1514 Series

- Powerful two jaw clutch
- Steel Hammer Case for strength and durability



ATP 1550EO-5S

ATP 1550 & 1552 Series

- Twin Hammer Mechanism for fast ultimate torque
- Powerful high output tools for demanding applications
- Steel Hammer Case Housing
- Easy repairable design
- 1552 series features a 7 vane rotor for awesome power to weight ratio



ATP 1520EI-5S

ATP 1520 Series

- Powerful Two Jaw Clutch for long life
- Good for soft or hard pull-up applications
- Steel Hammer Case for durability



ATP 2119EI-TH

ATP 2119 & ATP 2120 Series

- Smooth, hard hitting impact mechanism design
- Steel hammer case for strength and durability
- 2119 models reverse bias power

1-3/8" - 1-1/2" Bolt Capacity (35mm - 38mm)

MODEL#	Working Torque FT LB (NM)	Max Torque FT LB (NM)	Handle Type	Drive Size	Socket Retainer	Length Inches	Weight Lbs.	Hose Size	Equivalent To
ATP 1550EI-TH	2500 (3400)	3000 (4067)	End Grip I-T	1-1/2" Sq.	Through Hole	14.5"	33	3/4"	IR2950B7
ATP 1550EO-TH	2500 (3400)	3000 (4067)	End Grip O-T	1-1/2" Sq.	Through Hole	14.5"	33	3/4"	IR2950A7
ATP 1550EI-5S	2500 (3400)	3000 (4067)	End Grip I-T	#5 Spline	Button	14.5"	33	3/4"	IR2950B1
ATP 1550EO-5S	2500 (3400)	3000 (4067)	End Grip O-T	#5 Spline	Button	14.5"	33	3/4"	IR2950A1
ATP 1552EO-TH	3300 (4474)	4000 (5424)	End Grip O-T	1-1/2" Sq.	Through Hole	14.5"	33	3/4"	IR3955A2Ti
ATP 1552EI-5S	3300 (4474)	4000 (5424)	End Grip I-T	#5 Spline	Button	14.5"	33	3/4"	IR3955B1Ti
ATP 1552EI-TH	3300 (4474)	4000 (5424)	End Grip I-T	1-1/2" Sq.	Through Hole	14.5"	33	3/4"	IR3955B2Ti
ATP 1514EI-TH	2400 (3254)	4000 (5424)	End Grip I-T	1-1/2" Sq.	Through Hole	16.5"	31.5	3/4"	CP0614-PALED
ATP 1514EO-TH	2400 (3254)	4000 (5424)	End Grip O-T	1-1/2" Sq.	Through Hole	16.5"	31.5	3/4"	CP0614-GALED
ATP 1520EI-TH	2500 (3400)	3000 (4067)	End Grip I-T	1-1/2" Sq.	Through Hole	14.7"	33.7	3/4"	CP6120-PASED
ATP 1520EI-5S	2500 (3400)	3000 (4067)	End Grip I-T	#5 Spline	Button	14.7"	33.7	3/4"	CP6120-PASEL
ATP 2119EI-TH*	2600 (3500) rev	3500 (4700)	End Grip I-T	1-1/2" Sq.	Through Hole	14.25	29	3/4"	Cleco WT-2119-12
ATP 2119EI-5S*	2500 (3400) rev	3500 (4700)	End Grip I-T	#5 Spline	Button	14.25	29	3/4"	Cleco WTS-2119
ATP 2120EI-TH	3000 (4000)	3500 (4700)	End Grip I-T	1-1/2" Sq.	Through Hole	14.25	29	3/4"	Cleco WT-2120-12
ATP 2120EI-5S	2800 (3500)	3800 (4700)	End Grip I-T	#5 Spline	Button	14.25	29	3/4"	Cleco WTS-2120

*Reverse Bias Power Models. All models available with extended anvil. Contact ATP Customer Service for more information. See Ozat Sockets starting on page 33. Ret ring information is provided for every socket in OZAT section.

Super Duty "Heavy Hitters" Impact Tools

Available in 1-1/2", 2-1/2" and 3-1/2" Drive Sizes



ATP 1516 RT-TH

ATP 1516 RT-TH Impact

- 3-Jaw Clutch delivers hard hitting blows
- Double closed grip handle, assist handle and twist handle for convenience and secure operation.



ATP 1578 LT-TH

ATP 1578 LT-TH ATP 1580 LT-TH

- Precision ball and cam mechanism
- Built-in Lubricator
- Vertical and horizontal hangers
- Assist handle



ATP 2588 LT-TH

ATP 2582 LT-TH ATP 2588 LT-TH

- Precision ball and cam mechanism
- Built-in Lubricator
- Vertical and horizontal hangers

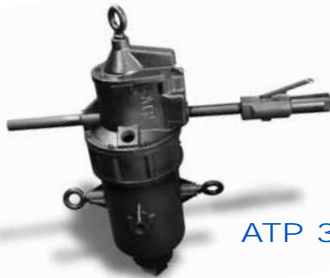

ATP 3599 LT-TH

ATP 3599 LT-TH The Worlds Most Powerful Impact Tool



- Precision ball and cam mechanism
- Built-in Lubricator
- Assist handle
- Vertical and horizontal hangers

1-1/2" - 4" Bolt Capacity (38mm - 102mm)

MODEL#	Working Torque FT LB (NM)	Max Torque FT LB (NM)	Handle Type	Drive Size	Socket Retainer	Length Inches	Weight Lbs.	Hose Size	Equivalent To
ATP 1516RT-TH	2800 (3796)	4400 (5965)	T-Handle Twist	1-1/2" Sq.	Through Hole	23"	73	3/4"	CP0616-SAMED
ATP 1578LT-TH	5500 (7456)	10000 (13560)	T-Handle Lever	1-1/2" Sq.	Through Hole	23"	86	1"	IR578A1
ATP 1580LT-TH	5900 (8000)	13560 (18383)	T-Handle Lever	1-1/2" Sq.	Through Hole	23"	88	1"	IR5980A1
ATP 2582LT-TH	10000 (13560)	20000 (27114)	T-Handle Lever	2-1/2" Sq.	Through Hole	25.4"	120	1"	IR5982A1
ATP 2588LT-TH	25000 (33892)	50000 (67784)	T-Handle Lever	2-1/2" Sq.	Through Hole	26.6"	215	1"	IR588A1
ATP 3599LT-TH	42000 (57000)	80000 (108500)	T-Handle Lever	3-1/2" Sq.	Through Hole	37.5"	599	1-1/2"	IR599A1

See Ozat Sockets starting on page 33. Ret ring information is provided for every socket in OZAT section.
See Retaining Rings and Pins for 2-1/2" on page 69, and 3-1/2" drives on page 71

Specialty Impact Tools



UNA DRIV[®] Impact Tools

The UNA DRIV[®] impact is a special tool that is used on UNA DRIV[®] bolts (see Picture). These bolts are used heavily in the manufacture and repair of railroad cars. In the center of the impact anvil is a male hex. This fits into the end of the bolt which keeps it from turning while the socket on the square drive drives the nut in place. Made in America with steel hammer case for greater durability in the toughest operating conditions.

Applications

- Railcar Manufacturing/Repair
- Tractor Trailer Manufacturing/Repair



UNA DRIV[®] Bolts



ATP 7508/VW834

UNA DRIV[®]

MODEL#	ATP 7508/VW834	ATP 7520/VW872
Torque Working Ft-Lb	100-450	250-800
Max. Ft.-Lb	450	800
Handle Type	Pistol Grip	Pistol Grip
Drive Size	3/4" Sq. UNA DRIV [®]	1" Sq. UNA DRIV [®]
Length In.	12	12
Weight	9.25 Lb.	13.25 Lb.
Hose Size	1/2"	1/2"
Equivalent To	IR2908/VW834	IR2920/VW872



ATP 7520/VW872

UNA DRIV[®] is a registered trademark of BBC Fasteners.

ATP - the name for all your special impact needs

ATP has over 80 years of experience in the design and manufacturing of specialty impact tools. Whether it is special materials, extended anvils, drive sizes or other specific requirements, ATP can deliver. Our special impacts have been in service in petrochemical plants, mining applications, underwater applications, steel mills, aluminum plants, chemical plants, military applications and more. Shown below are just a few of our special impacts.



Extended anvils available to your specification for all impacts.



Specialty Impact Tools



ATP 7560 PT-1Z
Two Jaw



3/4" CAPACITY (19mm)

MODEL#	ATP 7560 PT-THZ	ATP 7560 PT-1Z
Torque Working Ft.-Lb	560	575
Max. Ft.-Lb	1000	1025
Handle Type	Pistol Grip	Pistol Grip
Drive Size	3/4" Sq.	1" Sq.
Retainer	Through Hole	Through Hole
Length In.	7.60	7.60
Weight	15 Lb.	15.1 Lb.
Hose Size	1/2"	1/2"
Equivalent To	CP6060 ZASAB	CP6060 ZASAK

ZAMAC

Why use Zamac for Power Tool Castings?

Zamac or ZA-12 (zinc) material is required by law in several countries where underground coal mining operations are being carried out.

The atmospheric conditions found in underground mining can cause a white powder to form on aluminum material (aluminum is typically used for housings on pneumatic tools). When the aluminum has been affected by this powder like growth, a spark may result if the housing is struck by a metal object. Given the environment, this sparking gives way to potential explosions.

The Zamac material used in the castings is spark proof and is unaffected by the atmospheric conditions found in underground mining. The ATP Zamac housing power tools are approved by the mining underwriters in the UK, Germany, Poland and Australia where aluminum power tools are not allowed.

Applications

- Underground Mining

See *Ozat Sockets* page 33



ATP 1040 EI-THZ
Twin Hammer

1-1/4" BOLT CAPACITY (32mm)*

MODEL#	ATP 1040 EI-THZ
Torque Working Ft.-Lb	1600
Max. Ft.-Lb	2000
Handle Type	End Grip I-T
Drive Size	1" Sq.
Retainer	Through Hole
Length In.	12.40
Weight	26.5 Lb.
Hose Size	3/4"



ATP 1011 EI-THZ
Two Jaw

1-3/8" BOLT CAPACITY (35mm)

MODEL#	ATP 1011 EI-THZ
Torque Working Ft.-Lb	1800
Max. Ft.-Lb	2800
Handle Type	End Grip I-T
Drive Size	Through Hole
Length In.	12.50
Weight	27.0 Lb.
Hose Size	3/4"
Equivalent To	CP0611ZASED



ATP 1520 EI-THZ
Two Jaw

1-1/2" BOLT CAPACITY (38mm)

MODEL#	ATP 1520 EI-THZ
Torque Working Ft.-Lb	2500
Max. Ft.-Lb	3500
Handle Type	End Grip I-T
Drive Size	1-1/2" Sq.
Retainer	Through Hole
Length In.	14.70
Weight	38 Lb.
Hose Size	3/4"
Equivalent To	CP6120ZASED

Die Grinders

ATP 9913 Series



Standard Equipment

ATP 9913 is built for the long haul. Encased in a rugged steel housing the ATP 9913's 1hp motor runs at 25,000 rpm's. Equipped with an Erickson 1/4" (6.4 mm) collet chuck for precise work and extra holding power for those tough jobs. The ATP 9913 is ideally suited for use with mounted points and carbide burrs.

With power to spare, the ATP 9913 is at home in the Die Shop, Foundry, Shipyard, Construction, Petrochemical, Machinery and Equipment Shop and Fabrication Shop. Its uses include die contouring, die repairing, weld cleaning, casting and forging clean-up, deburring, blending and smoothing of rubber, plastics, composites, fiberglass, steel, brass, bronze, cast iron and aluminum materials.

ATP 4420 is a rugged 1/2 HP air motor encased in steel for heavy duty use and longer service life. Unique 3 ball bearing design reduces vibration for better ergonomics. One piece hardened and chrome plated spindle comes standard with 1/4" collet; 6 mm, 1/8", and 5/16" collets are available as optional collets.



ATP 9913

ATP 9913LS

ATP 4420

ATP 9913 DIE GRINDERS

MODEL#	Throttle Type	Free Speed rpm	Standard Spindle	Overall Length in. (mm)	Outside Diameter in. (mm)	Net Weight lb. (kg)	Motor Housing	Exhaust
ATP 9913	Lever	25,000	1/4" collet	6-1/4" (158mm)	1-3/4" (44mm)	2 lbs. 0.9 kg	Steel	Front*
ATP 9913-LS	Lever	25,000	1/4" collet	11-1/8" (283mm)	1-3/4" (44mm)	3 lbs. 1.4 kg	Steel	Front
ATP 9913ST	Safety	25,000	1/4" collet	6-1/4" (158mm)	1-3/4" (44mm)	2 lbs. 0.9 kg	Steel	Front
ATP 9913LS-ST	Safety	25,000	1/4" collet	11-1/8" (283mm)	1-3/4" (44mm)	3 lbs. 1.4 kg	Steel	Front
ATP 9913-18	Lever	18,000	1/4" collet	6-1/4" (158mm)	1-3/4" (44mm)	2 lbs. 0.9 kg	Steel	Front
ATP 4420	Lever	23,000	1/4" collet	6.8" (173 mm)	1-7/16"	1.7 lbs. 0.76 kg	Steel	Front
ATP 4420A	Lever	23,000	1/4" collet	6.8" (173 mm)	1-7/16"	1.0 lb. 0.45 kg	Aluminum	Front

Also available with Safety Lock-off Lever. Specify 9913 ST or 9913 LS-ST for models with Safety Lock-off Lever.

Standard Equipment: Erickson 1/4" (6.4mm) Chuck

***Optional Side Exhaust Model** available as ATP 9913R - For use as a Router or Side Exhaust Tool.

Collet Wrenches for 9913 9/16" C-116858, 5/8" x 3/4" C-119327

Angle Grinders

ATP 9940 Series

These Angle Grinders with their rugged .6 hp motors are primarily used with 3" and 4" Type 27 grinding wheels. They can be used for many cleaning, deburring, blending and smoothing applications found at ship yards, foundries, refineries, fabrication shops, power plants and a variety of other industries.

Features:

- 13,500 rpm free speed
- Short or Long Models
- 1/2" Side-to-Center distance for work in close quarters
- Adjustable side exhaust deflector – directs exhaust away from operators and the work area.
- Lock-Off safety handle standard
- Interchangeable parts with the ATP Die Grinder 9913 to reduce your spare parts inventory



ATP 9940-3



ATP 9940L-4

ATP 9940 ANGLE GRINDERS

MODEL#	Angle Housing	Free Speed rpm	Wheel Guard Dia. In. (mm)	Spindle Thread In.	Overall Length in. (mm)	Net Weight lb. (kg)	Motor Housing
ATP 9940-3	Short	13,500	3" (76mm)	3/8" - 24	7-5/8" (194mm)	3 lbs. 1.4 kg	Steel
ATP 9940-4	Short	13,500	4" (102mm)	3/8" - 24	7-5/8" (194mm)	3 lbs. 1.4 kg	Steel
ATP 9940L-3	Long	13,500	3" (76mm)	3/8" - 24	10" (254mm)	3.3 lbs. 1.5 kg	Steel
ATP 9940L-4	Long	13,500	4" (102mm)	3/8" - 24	10" (254mm)	3.3 lbs. 1.5 kg	Steel

All 4 models are available with Optional Safety Lock-off Throttle.

When ordering, simply add "ST" to above model numbers, i.e. ATP 9940-3-ST

Vertical Grinders

3HP ATP 356 Series



Specifications

Standard Equipment

All VSL models include:

- Safety Lock-off Lever Throttle
- Wheel Flange (2") and Spindle Nut
- Wheel Guard (as specified by model)
- Spindle Wrench 1100-200 (2") and 1102-015 (5/32") Allen Type Wrench

Extra Cost Equipment:

- Spindle/Wheel Retention Screw and Retention Screw Collar 650-60
- Optional wheel guards

Features

- 12+ models to choose from
- Built in lubricator
- Stainless steel corrosion resistant governors
- Speeds From 4,500 - 6,000 RPM's
- Ergonomic user friendly and easy to service
- "Techalloy" housing provides the ultimate in strength in a light-weight casting



ATP 356VSL-45-7

Vertical Safety Lever
3 hp, 4500 rpm
7" Guard



ATP 356VSL-60-6

Vertical Safety Lever
3 hp, 6000 rpm
6" Cup/Wire Brush



ATP 356VSL-60-7

Vertical Safety Lever
3 hp, 6000 rpm
7" Guard



ATP 356VSL-60-9

Vertical Safety Lever
3 hp, 6000 rpm
9" Guard

356 Series

MODEL#	Wheel Guard	Wheel Capacity Diameter In. (mm)	Weight Less Guard	Height to bottom of Flange	Side to Center Distance	Spindle Thread (Inch)	Air Inlet Thread	Hose Size (ID)	Free Speed RPM	Rated hp
ATP 356VSL-45-7	Type 27	7" (178)	7-3/8 lbs. 3.3 Kg	5-1/2" 145mm	1-11/16" 43mm	5/8"-11	1/2" NPT	1/2" 13mm	4500	3 2.2kW
ATP 356VSL-60-6	6" Cup/Wire Brush	6" (152)	7-3/8 lbs. 3.3 Kg	5-1/2" 145mm	1-11/16" 43mm	5/8"-11	1/2" NPT	1/2" 13mm	6000	3 2.2kW
ATP 356VSL-60-7	Type 27	7" (178)	7-3/8 lbs. 3.3 Kg	5-1/2" 145mm	1-11/16" 43mm	5/8"-11	1/2" NPT	1/2" 13mm	6000	3 2.2kW
ATP 356VSL-60-9	Type 27	9" (229)	7-3/8 lbs. 3.3 Kg	5-1/2" 145mm	1-11/16" 43mm	5/8"-11	1/2" NPT	1/2" 13mm	6000	3 2.2kW

Vertical Grinders

4HP ATP 466 Series



ATP 466VSL-45-7

Vertical Safety Lever
4 hp, 4500 rpm
7" Guard



ATP 466VSL-60-6

Vertical Safety Lever
4 hp, 6000 rpm
6" Cup/Wire Brush



ATP 466VSL-60-7

Vertical Safety Lever
4 hp, 6000 rpm
7" Guard



ATP 466VSL-60-9

Vertical Safety Lever
4 hp, 6000 rpm
9" Guard

C A U T I O N

NEVER OPERATE A GRINDER WITHOUT THE PROPER GUARD IN PLACE. NEVER USE A GRINDING WHEEL, WIRE BRUSH OR ANY OTHER ACCESSORY THAT IS NOT RATED FOR THE SPEED AS MARKED ON THE GRINDER. NEVER MOUNT A GRINDING WHEEL ON A SANDER. Failure to Read and follow the safety instructions included with power tools could result in serious injury or death.



WARNING: To reduce the risk of injury, all operators and maintenance personnel must read and understand the grinder safety instructions before operating, changing accessories or performing maintenance on ATP Grinders.

466 Series

MODEL#	Wheel Guard	Wheel Capacity Diameter In. (mm)	Weight Less Guard	Height to bottom of Flange	Side to Center Distance	Spindle Thread (Inch)	Air Inlet Thread	Hose Size (ID)	Free Speed RPM	Rated hp
ATP 466VSL-45-7	Type 27	7" (178)	9-1/2 lbs. 4.3 Kg	6-7/16" 174mm	1-7/8" 48mm	5/8"-11	1/2" NPT	1/2" 13mm	4500	4 3kW
ATP 466VSL-60-6	6" Cup/ Wire Brush	6" (152)	9-1/2 lbs. 4.3 Kg	6-7/16" 174mm	1-7/8" 48mm	5/8"-11	1/2" NPT	1/2" 13mm	6000	4 3kW
ATP 466VSL-60-7	Type 27	7" (178)	9-1/2 lbs. 4.3 Kg	6-7/16" 174mm	1-7/8" 48mm	5/8"-11	1/2" NPT	1/2" 13mm	6000	4 3kW
ATP 466VSL-60-9	Type 27	9" (229)	9-1/2 lbs. 4.3 Kg	6-7/16" 174mm	1-7/8" 48mm	5/8"-11	1/2" NPT	1/2" 13mm	6000	4 3kW

Horizontal Grinders

3 & 4 HP ATP 356 & 465 Series



Standard Equipment

All HSL models include:

- Safety Lock-off Lever Throttle
- Wheel Flange (2") and Spindle Nut
- Wheel Guard (as specified by model)
- Spindle Wrench 1100-200 (2") and 1102-015 (5/32") Allen Type Wrench

Extra Cost Equipment:

- Spindle/Wheel Retention Screw and Retention Screw Collar 650-60
- Optional wheel guards



ATP 356HSL-45-8

Horizontal Safety Lever
3 hp, 4500 rpm
8" Guard



ATP 356HSL-60-6

Horizontal Safety Lever
3 hp, 6000 rpm
6" Guard



ATP 465HSL-45-8

Horizontal Safety Lever
4 hp, 4500 rpm
8" Guard



ATP 465HSL-60-6

Horizontal Safety Lever
4 hp, 6000 rpm
6" Guard

356 & 465 Series

MODEL#	Wheel Guard	Wheel Capacity Diameter In. (mm)	Weight Less Guard	Height to bottom of Flange	Side to Center Distance	Spindle Thread (Inch)	Air Inlet Thread	Hose Size (ID)	Free Speed RPM	Rated hp
ATP 356HSL-45-8	8"	8" Straight Wheels or Wire Brush	10-1/2 lbs. 4.8 Kg	20-1/8" 524mm	1-1/4" 32mm	5/8"-11	1/2" NPT	1/2" 13mm	4500	3 2.2kW
ATP 356HSL-60-6	6"	6" Straight Wheels or Wire Brush	10-1/2 lbs. 4.8 Kg	20-1/8" 524mm	1-1/4" 32mm	5/8"-11	1/2" NPT	1/2" 13mm	6000	3 2.2kW
ATP 465HSL-45-8	8"	8" Straight Wheels or Wire Brush	12-1/2 lbs. 5.67 Kg	20-7/8" 530mm	1-1/4" 32mm	5/8"-11	1/2" NPT	1/2" 13mm	4500	4 3.3kW
ATP 465HSL-60-6	6"	6" Straight Wheels or Wire Brush	12-1/2 lbs. 5.67 Kg	20-7/8" 530mm	1-1/4" 32mm	5/8"-11	1/2" NPT	1/2" 13mm	6000	4 3.3kW

Scaler Tools



ATP needle and chisel scalers are offered in a compact design for close quarter work removing weld flux, paint, scale, weld spatter, rust and other residue from a variety irregular surfaces in fabrication shops, shipyards foundries, refineries, construction sites and MRO applications.

Features:

Rugged design and precision manufacturing specifications make these Scalers last longer with low maintenance costs. Model A-1ALT Scaler quickly converts to Needle Scaler for better tool utilization.



ATP A-1ALT
Weld Flux Scaler



ATP A-1ALTNS
Needle Scaler



ATP A-1ACO
Coke Oven Scaler



ATP A-A1AS
Solid Back
Head Scaler

ATP SCALERS

MODEL#	Scaler Model Type	Throttle Type	Bore x Stroke in. (mm) x in. (mm)	Weight		Length		Inlet Size
				lb.	kg	in.	mm	
ATP A-1ALT	Weld Flux Scaler	Lever	1 (25.4) x 1-1/8 (28.8)	4.5	2.17	9-1/2	243	1/4" NPT
ATP A-1ALTNS	Needle Scaler	Lever	1 (25.4) x 1-1/8 (28.8)	6	2.7	17-1/2	448.7	3/8" NPT
ATP A-1AS	Solid Back Head Scaler	*Solid Type	1 (25.4) x 1-1/8 (28.8)	4	1.81	8-1/2	217.9	1/2" NPT
ATP A-1ACO	Coke Oven Scaler	Coke Oven	1 (25.4) x 1-1/8 (28.8)	5	2.27	11-5/8	298	1/2" NPT
ATP A-1APT	Push Throttle Scaler	Push Type	1 (25.4) x 1-1/8 (28.8)	4.5	2.17	10	256.4	1/4" NPT

*A-1AS has no throttle built into the tool.
All models 4,600 blows per minute (BPM).

Chipping Hammers

ATP's Heavy Duty Chipping Hammers

ATP Chippers are ergonomically advanced in design, with a "HEAVY DUTY" alloy aluminum handle. Our chipping hammer's crisp, smooth valve operation produces extra hard hitting power, while our heat treated alloy steel cylinder and piston provide long life. Available in the popular 1"-2"-3"-4" stroke versions with either Hex or Round chisel bushing and in either Alloy Aluminum or Steel Handle. The closed grip handle design locates the operators arm in-line with the chisel for maximum effectiveness and comfort.

Favored by contractors and Industrial users alike, this new ATP Chipper sets new standards for American made pneumatic tools. Available in either Round or Hex chisel bushings, and in either Alloy Aluminum or Steel Handles. If you need a **RUGGED, RELIABLE PERFORMER** on your job site, you can't do better than the new **ATP ERGONOMIC CHIPPING HAMMER**.

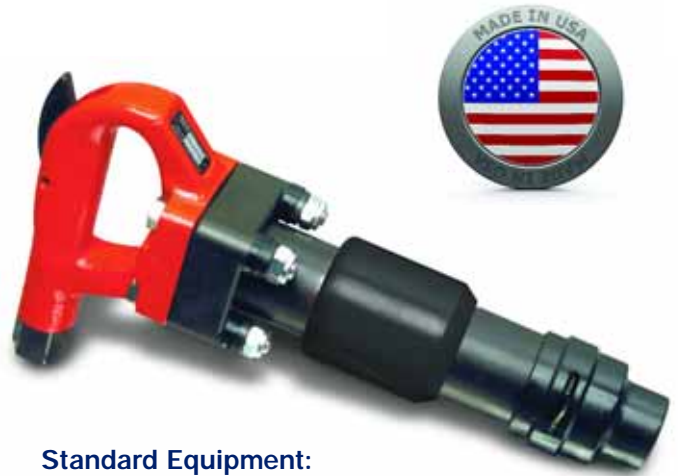

Standard Equipment:

- Oval Collar Retainer P/N 250012-525
- Spring P/N 250012-529

Optional Equipment:

- Nozzle Bushing Removal Tool
P/N 3CH-931
- Exhaust Deflector Extension Tool
P/N 3CH-932
- Long Reach Handle Conversion Kit
P/N LCH-1A
- 1/2" Hose Barb Inlet

ATP CHIPPING HAMMERS

MODEL#	Weight		Length Less Retainer	BPM	Bore x Stroke (Inches)	Chisel Bushing	Air Consumption
	Aluminum	Steel					
ATP-1HB	13.3 lbs.	17 lbs.	12.75"	2600	1-1/8" x 1"	.580 Hex	26 cfm
ATP-1RB	13.3 lbs.	17 lbs.	12.75"	2600	1-1/8" x 1"	.680 Round	26 cfm
ATP-2HB	13.7 lbs.	17.2 lbs.	14"	2300	1-1/8" x 3"	0.580 Hex	26 cfm
ATP-2RB	13.7 lbs.	17.2 lbs.	14"	2300	1-1/8" x 3"	0.680 Round	26 cfm
ATP-3HB	14.8 lbs.	18.5 lbs.	15.25"	2100	1-1/8" x 3.75"	.580 Hex	30 cfm
ATP-3RB	14.8 lbs.	18.5 lbs.	15.25"	2100	1-1/8" x 3.75"	.680 Round	30 cfm
ATP-4HB	15.8 lbs.	19.5 lbs.	16.5"	1700	1-1/8" x 4.25"	.580 Hex	33 cfm
ATP-4RB	15.8 lbs.	19.5 lbs.	16.5"	1700	1-1/8" x 4.25"	.680 Round	33 cfm
ATP-1LRHB	-	24 lbs.	48.75"	2600	1-1/8" x 1"	.580 Hex	26 cfm
ATP-1LRRB	-	24 lbs.	48.75"	2600	1-1/8" x 1"	.680 Round	26 cfm
ATP-2LRHB	-	24.1 lbs.	50"	2300	1-1/8" x 3"	.580 Hex	26 cfm
ATP-2LRRB	-	24.1 lbs.	50"	2300	1-1/8" x 3"	.680 Round	26 cfm
ATP-3LRHB	-	25.6 lbs.	51.4"	2100	1-1/8" x 3.75"	.580 Hex	30 cfm
ATP-3LRRB	-	25.6 lbs.	51.4"	2100	1-1/8" x 3.75"	.680 Round	30 cfm
ATP-4LRHB	-	26.6 lbs.	52.5"	1700	1-1/8" x 4.25"	.580 Hex	33 cfm
ATP-4LRRB	-	26.6 lbs.	52.5"	1700	1-1/8" x 4.25"	.680 Round	33 cfm

To order with aluminum handle add **A** after stroke, ex. ATP-2AHB

Chipping Hammers



ATP 4 Bolt Chipping Hammer with Thread on Retainer

The 3" stroke versions of the ATP Heavy Duty Chipping Hammers are available with Rubber Buffered Thread on Retainer for Round Collar Chisels. The ATP Chipping Hammer is ideally suited for chipping of steel castings, concrete roughing and chipping heavy duty weld seams. ATP's new Ergonomically designed Alloy Aluminum "Heavy Duty" Handle eliminates 3.68 lbs. of total tool weight. Our crisp smooth valve operation produces extra hard hitting power, while our heat treated alloy steel cylinder and piston provide long life.

Favored by contractors and Industrial users alike, this new ATP Chipper sets new standards for American made pneumatic tools. Available in either Round or Hex chisel bushings, and in either Alloy Aluminum or Steel Handles. If you need a **RUGGED, RELIABLE PERFORMER** on your job site, you can't do better than the new **ATP ERGONOMIC CHIPPING HAMMER**.

Standard Equipment:

Thread on Retainer, buffer and spring on Thread on Barrel model only.



ATP 3AHBTR



Optional Thread on Retainer

Available on 3" Stroke only

ATP Chippers are Ergonomically Advanced in Design, the Ergonomic Closed Grip Handle locates the operator's hand and arm in-line with the chisel for maximum effectiveness and operator comfort. This makes the ATP Chipper much easier to handle and less fatiguing when used over long periods of time.

ATP CHIPPING HAMMERS

MODEL#	Weight		Length Less Retainer	BMP	Bore x Stroke (Inches)	Chisel Bushing	Air Consumption
	Aluminum	Steel					
ATP 3AHBTR	14.8 lbs	-	15"	2100	1-1/8" x 3.75"	Hex	30 cfm
ATP 3HBTR	-	18.5 lbs.	15"	2100	1-1/8" x 3.75"	Hex	30 cfm
ATP 3ARBTR	14.8 lbs	-	15"	2100	1-1/8" x 3.75"	Round	30 cfm
ATP 3RBTR	-	18.5 lbs.	15"	2100	1-1/8" x 3.75"	Round	30 cfm

Breakers



®
**Legendary Construction
 Air Tools Since 1886**



Thor Breakers

Thor Breakers, available in the 30, 60 and 90 lb Class, are "Tools as Tough as their name". The 30 lb class Thor 17 Breakers are light weight rugged tools designed for light to medium construction and plant maintenance work such as demolition of floors, pavement, masonry walls, black top and frozen dirt. The 17 is also an excellent choice for bridge deck demolition work.

The Thor 234 60 lb Class and Thor 125 90 lb. Class Breakers are designed to deliver the performance and endurance necessary for a variety of heavy duty construction and plant maintenance applications, such as breaking rock, concrete, reinforced concrete, frozen earth and pavement.

Features of all Thor Breakers:

- Alloy steel forgings
- Precision American machined parts for long life
- Rugged 4 bolt design for extra duty service.
- Continuous lubrication provided by internal oilers for long service life
- Air inlet swivel for maneuverability.



17
 17-1
 (30lb Weight Class)



234-1.125
 234-1.25
 (60lb Weight Class)



125-1.125
 125-1.25
 (90lb Weight Class)

THOR BREAKERS

MODEL#	Air Inlet	Chuck Size	Bore x Stroke in. (mm) x in. (mm)	BPM	Length in. mm	Weight lb. kg	CFM
17	3/8" NPT, male	7/8" x 3-1/4"	1-3/4" (44) x 3-3/8" (86)	1550	22-1/2" (572mm)	32 lbs. (14.5 kg)	46
17-1	3/8" NPT, male	1" x 4-1/4"	1-3/4" (44) x 3-3/8" (86)	1550	22-1/2" (572mm)	32 lbs. (14.5 kg)	46
ATP 234-1.125	3/4" NPT, male	1-1/8" x 6"	2-1/4" (57) x 4.0937" (104)	1400	25-5/8" (651mm)	67 lbs. (30 kg)	60
ATP 234-1.25	3/4" NPT, male	1-1/4" x 6"	2-1/4" (57) x 4.0937" (104)	1400	25-5/8" (651mm)	67 lbs. (30 kg)	60
ATP 125-1.125	3/4" NPT, male	1-1/8" x 6"	2-5/8" (66.67) x 6-1/16" (154)	1250	28-3/4" (730mm)	92 lbs. (42 kg)	80
ATP 125-1.25	3/4" NPT, male	1-1/4" x 6"	2-5/8" (66.67) x 6-1/16" (154)	1250	28-3/4" (730mm)	92 lbs. (42 kg)	80

Clay Diggers



®
**Legendary Construction
 Air Tools Since 1886**

Thor 18 "Digger"

Thor 18 CD is a dropped forged clay digger recommended for digging clay in packed soil from around footings, forms and other construction areas. It's 29 lb. weight makes it a hard hitting tool, making quick work of the task at hand.

Features:

- Slim design for work in tight areas.
- Heat treated alloy steel components.
- Latch retainers for positive retention and quick change of accessories.



THOR 18CD-.875
 THOR 18CD-1

THOR Clay Digger

MODEL#	Air Inlet	Chuck Size	Bore in. (mm)	BMP	Length in. mm	Weight lb. kg	CFM
18CD-.875	3/8" NPT, male	7/8" Hex x 3-1/4"	1-3/4" (44.8)	1500	22-3/4" (583mm)	29 lbs. (13 kg)	38
18CD-1	3/8" NPT, male	1" Hex x 4-1/4"	1-3/4" (44.8)	1500	22-3/4" (583mm)	29 lbs. (13 kg)	38

Thor Rivet Buster



The Thor RB-11 Demolition Tool and Rivet Buster with its powerful 11" stroke is the ideal demolition tool for medium to heavy concrete demolition on bridge decks, parking garage columns, bridge pillars and large rivet and bolt cutting applications.

Features:

- Rugged ergonomic closed grip with inside trigger for solid comfortable grip while protecting the trigger from external damage
- Hardened steel piston and cylinder for excellent wear resistance and long life
- Uses standard 11x Jumbo steel
- Teasing throttle for exceptional starting and control

THOR RB-11

THOR RB-11

MODEL#	Air Inlet	Bore x Stroke in. (mm) x in. (mm)	BPM	Length in. mm	Weight lb. kg	CFM
RB-11	1/2" NPT, female	1-3/16" (30) x 11" (279)	850	25-1/2" (648mm)	33 lbs. (15 kg)	50

Thor Back Fill Tamper

Thor's 6T Backfill Tamper is a 40 lb. Class Tamper that has also "Stood the Test of Time". Its slow (800 BPM) powerful blows provide a well balanced, smooth operating tool that is easily guided by one person. Thor designed to effectively compact soil around foundations and other structures and for compacting backfill in trenches and other construction holes requiring compaction.

Features:

- High power to weight ratio, slow powerful blows quickly compact all types of backfill material including clay and gravel
- Heat treated cylinder and piston for long service life
- Hex Head Bolt Clamp Screw for quick and easy butt changes, no more stripped out screwdriver slots



THOR 6T

THOR 6T Backfill Tamper (40 lb. class)

MODEL#	Air Inlet	Taper	Bore x Stroke in. (mm) x in. (mm)	BPM	Length in. mm	Weight lb. kg	CFM
6T	1/2" NPT, female	804 Taper	1-1/2" (38) x 5-1/2" (140)	800	48-1/4" (1226mm)	40 lbs. (18 kg)	38

Thor Concrete Scabblers



® **Legendary Construction**
Air Tools Since 1886

Thor U-Type Scabbler Tools are specifically designed for all types of concrete surface work where it is necessary to carry out surface hammering without in any way causing damage to the basic concrete. Stadium seating, floors, concrete walkways, retaining walls, bridges, airport runways, or similar large areas where it is required to expose the aggregate prior to top coating.

The machines are mounted on wheels for ease of transportation, but while the machines are operating the wheels rise clear of the working surface and the machines virtually float, enabling them to be manipulated with ease in a scything motion. Handle design gives good balance and control, together with conveniently place "on/off" valve, makes machine operation extremely simple for the operator.



U5 (shown)

THOR U-TYPE MULTI-SCABLERS

MODEL#	U5	U7	U11
Overall Length Including Handle	50" (1270 mm)	50" (1270 mm)	50" (1270 mm)
Working Width Over Bits	11-1/4" (286 mm)	15-3/4" (400 mm)	19" (483 mm)
Total Width Over Wheels	25" (635 mm)	30" (762 mm)	33" (833 mm)
CFM	150	200	300
Hose Size	1" (25.4 mm)	1" (25.4 mm)	1" (25.4 mm)
Weight	214 lbs (97 kg)	266 lbs (121 kg)	308 lbs (140 kg)
Length In.	50" (1270 mm)	50" (1270 mm)	50" (1270 mm)
Scabbling Rate ft ² /hr x 1/8" deep (m ² /hr x 1/8")	225'-338' (21-31 m)	315'-472' (29-44 m)	495'-742' (46-69 m)
Number of Bits	5	7	11

Air Centrifugal Sump Pump



ATP 551P

ATP 551P Sump Pump

The new ATP-551P is a light weight, portable, air operated, fully submersible sump pump with the power to pump up to 216 gallons of water per minute. This non-clogging, self-cleaning pump for clean or dirty water, sewage, oil and sludge is capable of handling all your pumping requirements. The rugged cast iron housing is built to take life's hard knocks. The built in Oiler will handle up to 16 hours of continuous Air Motor lubrication. Convenient Carry Handles make this versatile pump easy to handle at the job site. The adjustable governor prevents "Run-away" when sump is pumped dry or if the impeller clears water while it is in operation.

Features

- Submersible, lightweight
- Portable
- Air operated
- Cast iron housing construction
- Steel impeller

Maximum Performance:

- Max Flow - 216 GPM
- Max Head - 92 Feet

Standard Equipment:

- Built in Oiler
- Extended Exhaust Pipe with check valve to prevent water from entering the motor through the exhaust

Optional Equipment:

- Air valve, lever type for remote operation. (at additional cost)

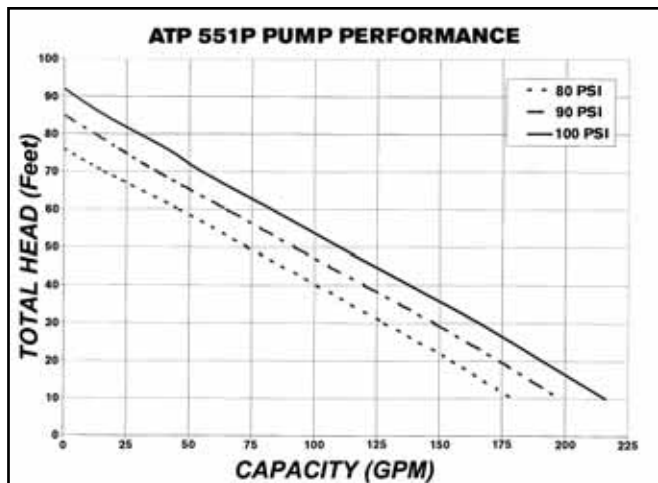

ATP 551P

MODEL#	Height		Weight		Opening Pump Will Enter	Discharge Opening	Air Inlet Thread	Pump Housing Material	CFM
	in.	mm	Lb.	Kg					
ATP 551P	20	513	41	18.6	8-5/8" x 10-1/2"	2-1/2" NPT female	1/2" NPT female	Cast Iron	75

*interchanges with THOR 51T

Air Hoists



ATP Air Hoist

Chain Hoists - 500 to 4000 lb. Capacity

Features:

- Self-locking worm gear design eliminates the need for brakes. The worm gear stops and holds loads securely when air flow to motor stops-never requires any adjustments
- Heat-treated alloy steel chain provides strength and flexibility
- Powerful ATP air motor provides positive high-torque starting characteristics
- All rotating parts supported on anti-friction bearings for smooth operations
- Housing of sectioned aluminum "Techalloy" castings provide extra strength and durability
- Automatic, adjustable limit stops - prevent over-travel, even at fastest speeds
- Withstands constant stopping, starting and stalling - without damage or overheating
- Operator speed control - for precise load spotting
- Remote pendant control - available in all sizes
- Standard safety cable attachment point provides secure installation

Applications:

The ATP 91200 extra heavy-duty hoist is designed to lift raw or processed materials in steel manufacturing plants, heavy assemblies in automobile, truck and tractor factories, aircraft, aerospace industries, heavy machinery manufacture, petrochemical plants and food processing operations.

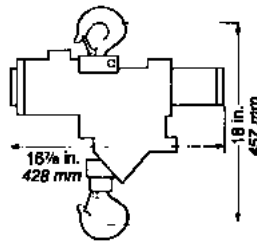

ATP 91200 (500-2000 lb.)

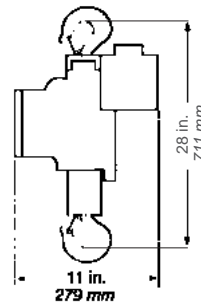

ATP 91200 (4000 lb.)



ATP 91200

ATP AIR HOISTS

MODEL#	Control Description	Rated Capacity		Lifting Hook Speed at Rated Capacity		Standard Lift Length		Pendent Length ft	Net Weight	
		lb.	(kg)	ft./min	(m/min)	ft	mm		lb.	(kg)
ATP 91200-DC	Pull Chain	500 lb.	(227)	44	(12.8)	15	(4.6)	10	60	(27.3)
ATP 91200-DP	Pendant Control	500 lb.	(227)	44	(12.8)	15	(4.6)	10	63	(28.6)
ATP 91200-MC	Pull Chain	1000 lb.	(455)	20	(6.1)	15	(4.6)	10	60	(27.3)
ATP 91200-MP	Pendant Control	1000 lb.	(455)	20	(6.1)	15	(4.6)	10	63	(28.6)
ATP 91200-2MC	Pull Chain	2000 lb.	(909)	12	(3.7)	15	(4.6)	10	60	(27.3)
ATP 91200-2MP	Pendant Control	2000 lb.	(909)	12	(3.7)	15	(4.6)	10	63	(28.6)
ATP 91200-4MC	Pull Chain	4000 lb.	(1818)	5	(1.5)	15	(4.6)	10	109	(49.5)
ATP 91200-4MP	Pendant Control	4000 lb.	(1818)	5	(1.5)	15	(4.6)	10	112	(50.9)

Standard Equipment: Swivel top latch hooks, built-in lubricators and air strainer, exhaust muffler, optional chain bucket C088945
Parts are available from ATP for the CP 1100 Chain Hoist.

Large Air Drills



ATP 2122-725WB Drill

The ATP 2122-725WB drills are designed for RUGGED, HEAVY DUTY drilling and reaming operations in the railroad, truck/tractor, petrochemical, machinery and construction industries. This heavy-duty drill is ideally suited for the heavy-duty MRO user.

Features

- Ball bearing support for long life and smooth operation
- Roll throttle for excellent speed control
- Governor-controlled motor conserves air at light loads, holds speed at peak horse power under heavy loading
- Internal oil reservoir reduces "downtime"
- External grease fitting for easy lubrication
- Self closing roll throttle with independent reverse

Standard Equipment:

- Breast Plate, assist handle, 1/2" shank, wood bore chuck

Optional Equipment:

- #2 Morse Taper Spindle or, 1/2" drill chuck

ATP 3500 Drills

ATP 3500 Drills are used for extra-heavy duty drilling, reaming, tapping and tube rolling for truck, tractor, railroad, shipbuilding, petrochemical machinery, building construction, equipment and the general construction industries.

Features:

- Reversible self-closing roll throttle for one-hand throttle control and reversing.
- Governor controlled motor conserves air at light loads, holds speed at heavier loads while increasing power
- Heavy-duty ball bearings for long life
- 5.9 Horse power motor and rugged gearing provides maximum power output
- Integral #5 Morse Taper female socket for fast, easy change overs and positive drill bit retention
- Feed screw for drilling or reaming down force



ATP 2122-725WB
*Shown with optional
1/2" Drill Chuck
and Morse Taper Spindle.



ATP 3500-100
ATP 3500-60

ATP 2122-725WB DRILL

MODEL#	Free Speed RPM	Weight		Height Over Spindle		Side To Center Distance		CFM	Spindle and Spindle Chuck
		Lb.	Kg	in.	mm	in.	mm		
ATP 2122-725WB	725	14.4	6.46	17.25	438	1-7/16	36	50	Threaded, 1/2" Shank Wood Bit Chuck

Also available in 230 rpm, 280 rpm, 350 rpm, 500 rpm, 1025 rpm and 1500 rpm. Spindle output can be configured to your requirements.

ATP 3500 Air Drill

MODEL#	Free Speed RPM	Weight lb. (kg)	Height Over Spindle in. (mm)	Side to Center in. mm	CFM	Spindle Size
ATP 3500-100	100	69 (31.4)	23-1/4" (591)	2-3/4" (69.9)	165	#5MT
ATP 3500-60	60	69 (31.4)	23-1/4" (591)	2-3/4" (69.9)	165	#5MT

Also available in 150 rpm, 200 rpm, 310 rpm, 400 rpm, 1000 rpm and 1800 rpm. Spindle output can be configured to your requirements.

Air Motors

ATP Air Motors

Use an ATP air motor wherever you need a reliable, install-it-and-forget-it source of power and an adequate source of compressed air is available.

Direct Drive and Geared Rotary Vane Motors

HP: 0.28 to 12.5
SPEEDS: 60 to 25,000 RPM
TORQUE: 1.5 in. lbs. to 1,225 ft. lbs.
MOUNTINGS: Foot, flange, face, hub
ROTATION: Reversible/Non-reversible



Applications:

- Strapping Machines
- Pumps
- Conveyors
- Screw Jacks
- Valves
- Mixing/Agitating
- Feed Rollers
- Parts Feeders
- Index Tables
- Clamping
- Boring
- Actuating
- Ladle Tilters
- Plating Tanks
- Cutters
- Stretchers
- Cable Twisters
- And many more...



ATP 3501 Series



ATP 318 Series



ATP 3800 Series

Features:

- Lightweight
- No electric shock hazard
- Variable Speed
- Custom Design
- Will withstand stalling or rapid reversal
- High starting torque
- Low maintenance
- Durable
- Mount in any position



ATP offers a wide range of standard air motors. ATP can also custom design motors for your unique applications. Contact ATP's customer service team for a quote or a copy of our air motor selection brochure.

email: info@hy-techinc.com
Fax: 724.776.0227
Toll Free: 1.800.245.1148

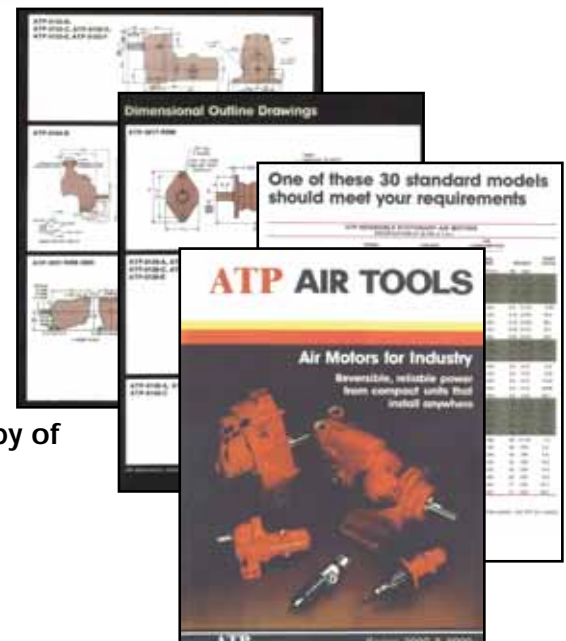

Jet Air Fan "Moving More Air by Design"



ATP-JA20 High Performance Air Mover

The engineering of the **JET AIR** blades cause more air to be pulled through the fan by our trailing edge design. By using the **ATP JET AIR** design, we are able to move more air in the forward direction like a Jet Prop, producing superior air flow with a lot less energy. The results are simple "We move more air by design at lower fan speeds using less energy than the competition does!"



Features:

- Used for general ventilation where compressed air power source is available.
- Designed for fixtured applications, easily mounting to a 20" API flange.
- Dynamically balanced 4 blade design for smoother operation.
- High visibility orange - powder coated stainless steel fan shroud for safety.
- Manufactured to aircraft tolerances & specifications.
- Moves more air by design, at air pressures between 40-110 psi (2.75 - 7.6 bar).
- Reduces air turbulence by design, smoother air flow at all RPM's using only 2 rotating parts.
- Hy-Tech bearing grease used in all high speed Jet Air Bearings.
- Can be used as a blower or exhauster by turning it around.

Ventilation Applications and Industries:

- Removal of hazardous fumes from tanks, process vessels, welding, sandblasting and other operations in confined areas.
- Used in Refineries, Chemical Plants, Shipyards, Power Generation, Paper Mills and Steel Fabrication Plants.

Specifications:

- Fan assembly shaft rotates on permanently sealed ball bearings.
- Air consumption at 60 PSI, 115 CFM @ 2,700 RPM.
- Fits 20" (508 mm) API tank opening bolt circle.
- Delivery - up to 11,200 CFM (19,029 m³/hr).
- Max 120 PSI, Working pressure 40-110 PSI.
- Weight 103 lbs (Shipping weight 113 lbs).
- Mounting slots 1 1/8" diameter.
- Air inlet 3/4" NPT.

ATP Venturi Air Movers "Air Horns"



Features:

- Used for portable ventilation where compressed air is available as a power source.
- Rugged "Tech-Alloy" aluminum casting.
- No moving parts to replace.
- Periodic steam cleaning for easy maintenance.
- Can pull air from confined areas or blow fresh air into area.
- Grounding wire and clamp - standard equipment.
- Will operate on compressed air or steam.

Ventilation Applications and Industries:

- Removal of hazardous fumes from tanks, process vessels, welding, sandblasting and other operations in confined areas.
- Cooling personnel, machinery or production product with a blast of air.
- Used in Refineries, Chemical Plants, Shipyards, Power Generation, Paper Mills and Steel Fabrication Plants.

MODEL#	Length	Base Diameter	Top Diameter	NPT Size	Weight	CFM Flow @ 80 PSI	CFM Used @ 80 PSI
ATP 3VAMS	16.75"	7.31"	6.0"	1/2"	5.5 LBS	1180	65
ATP 3VAM	30.5"	7.31"	7.0"	1/2"	8.5 LBS	1450	65
ATP 6VAM	44.25"	11.25"	12.5"	1"	22.0 LBS	3350	125
ATP 8VAM	46.0"	14.37"	14.25"	1"	36.0 LBS	4930	195
ATP 10VAM	48.0"	17.0"	15.75"	1"	42.0 LBS	7300	275

Strict precautions may be required when using any air horn. To reduce the risk of injury, all operators and maintenance personnel must read and follow the safety instructions before operating the air horns. Failure to read and follow the safety instructions could result in serious injury or death.

Product Safety Note: Always attach a grounding cable. Grounding clamp and wire must be used to prevent static electricity build up which could cause a spark.

Railcar Gate Openers



ATP Hopper Car Slide Gate Door Opener Line

Our simple designs to meet your varying needs.



ATP PDO7

ATP PDO5



ATP PDO9

The **ATP-PDO5** is a one person, trouble free machine used to open railcar slide gates. Designed and engineered for economy, speed and operator safety, this rugged compact opener is both powerful and mobile. Its compressed air drive motor and mechanism delivers 8000 ft. pounds of torque at the operator's fingertips. It is reversible, so it can open doors as well as close them.

ATP-PDO7 has all the qualities and benefits of the ATP-PDO5, plus the capacity of the wheels that pivot sideways at the touch of a switch for opening or closing traveling knuckles. The wheels then return to their original position to move on to the next gate.

ATP-PDO9 has wheels that pivot like the ATP-PDO7 needed for traveling gates. However, it has lever actuated adjustable elevation for varying gate heights. (12" adjustable spread with a 24" maximum height).

SPECIAL HOPPER CAR GATE SOCKETS

PART#	FEMALE	MALE TAPER	LENGTH
HEX-3	1-1/2" sq.	3/4" sq. to 1-7/8" sq	10"
HEX-3-10	1-1/2" sq.	3/4" sq. to 1-7/8" sq.	20"
HEX-12	2-1/2" sq.	3/4" sq. to 1-7/8" sq	12"



PART#	DESCRIPTION	SIZE	LENGTH
AN2424	Double ended female adaptor	1-1/2" x 1-1/2" sq.	3.35"
Z2410	Double ended male adaptor	1-1/2" x 1-1/2" sq.	10"

Features

- **SAFE** - eliminates the danger of accidents incurred while manually opening hopper car gates.
- **FAST** - opens the most stubborn gates in about 4 seconds.
- **RELIABLE** - designed and engineered for years of trouble free service.
- **VERSATILE** - works in any and all weather conditions with no inherent shock hazards.
- **MOBILE** - oversize pneumatic tires make it easy to roll almost anywhere.
- **REVERSIBLE** - opens and closes railroad car slide-gate doors.
- **POWERFUL** - compressed air coupled to the impact mechanism produces the power of a giant.
- **PRACTICAL** - Simple one person operation.

Call or ask your sales representative about a demonstration video.

Air Tool Lubricants

Oil and Grease



ATP Ice Free "BLUE MAGIC" Air Tool Lubricant For Pneumatic Tools

This oil is especially compounded for lubricating Air Impact Tools, Hammers, Drills, Grinders, Pumps, Breakers, Air Motors and other Pneumatic Tools. Moisture in compressed air will rapidly wash away most lubricating oils used in Air Tools. "BLUE MAGIC" oil, however, has additives that absorb such moisture into the lubricant, forming a stable emulsion which clings to the inside of the tool. It not only lubricates and rustproofs, but it prevents "ice" from forming in the tool's exhaust. During idle time, there is no separation of moisture and oil. This constantly maintained protective film prevents rust and corrosion in the inside of air tools.

IMPORTANT:

When using "BLUE MAGIC" Ice Free Oil in Air Line Lubricators, adjust the feed rate to approximately 1/3 that used with regular oil. "BLUE MAGIC" oil **does not** wash out of air tools as rapidly as regular oils do.

Blue Magic Oil

PART#	Container Size	Case Quantity
P-137646	Pint	24
P-137145	Quart	12
P-089507	Gallon	4

Impact Mechanism (Clutch) Lubricant "Pure Gold"

A superior synthetic moly-based extreme pressure lubricant for use in all types of grease lubricated impact mechanisms, anvil bushings and high speed air motor bearings.

Pure Gold Lubricant

PART#	Container Size
CA-131898	14.5 oz Cartridge
C-131689	7-1/2 lb. Pail



Air Line Accessories

ATP Automatic In-line Oilers

ATP automatic in-line oilers, (football type). The ATP automatic in-line oilers are designed to supply oil for tool lubrication anywhere stationary lubricators are not feasible to use. Automatic in-line oilers should be installed as close to the air tool as possible. The ATP automatic in-line oilers have an adjustable needle valve flow control to permit easy regulation of oil flow. Oil flow while using ATP's ice free "Blue Magic" air tool lubricant should be set at approximately one drop per minute. The rugged cast housing provides long service life under the most severe service conditions.



MOISTURE SEPARATOR WITH AUTOMATIC DRAIN

MODEL#	INLET	OUTLET	RATED PRESSURE
S7F	3/4" NPT	3/4" NPT	100 PSI

Weight: 11 lbs

Dimensions: 6" Dia. x 9.5"



IN-LINE OILER

PART#	Thread NPT/Hose Barb Pipe Size	Max. Working Pressures (PSI)	Recommended Oil Wt./Capacity (FL. OZ.)
ATP-0L	1/2" NPT	500	ATP Blue Magic/5 Wt. 1.4 Fl. Oz.
ATP-1L	3/4" NPT	260	ATP Blue Magic/5 Wt. 4.0 Fl. Oz.
ATP-2L	3/4" NPT	300	ATP Blue Magic/5 Wt. 11.0 Fl. Oz.
ATP-3L	1" NPT	250	ATP Blue Magic/5 Wt. 16.0 Fl. Oz.

Repair kit for In-line Oiler ATP-LRK

Air Line Accessories



Standard Universal Hose Couplings

ATP Universal Hose Couplings are a rugged rust proof one-piece design with the convenience of a quarter turn connect/disconnect feature. The design increases holding power and seal with increase in air pressure. The gaskets will not blow or fall out. The same size coupling end is used on all sizes making for easy interchange of different size hose assemblies. The coupling gaskets are made of high-grade materials that retain their effective resiliency indefinitely. Gaskets are easily installed using only your fingers. No special tools are required for installation!

WARNING: ALWAYS use a coupling lock pin (part number C142110) to prevent injury from accidental uncoupling of universal hose couplings. Whip hoses can cause serious injury!

Special Large Size Universal Couplings:

These have the same advantages of the Standard Universal Couplings except there is no interconnect ability with standard sizes.

Size	Bronze Part Number
1-1/2" NPT Male Pipe Thread	C-015145
1-1/2" NPT Female Pipe Thread	C-015175
1-1/2" Diameter Hose I.D.	C-015176

Rubber gasket for large Universal Couplings, C015071

*One gasket supplied with each coupling

Coupling Accessories

Dead End Cap	C-035019
3 Way Coupling	C-035021
Rubber Gasket	C-035138



Male Thread Coupling

Size NPT Male Pipe Thread	Bronze Part Number
3/8"	C-015123
1/2"	C-015122
3/4"	C-015121
1"	C-015120



Female Thread Coupling

Size NPT Female Pipe Thread	Bronze Part Number
3/8"	C-015128
1/2"	C-015127
3/4"	C-015126
1"	C-015125



Hose End Coupling

Size Hose I.D.	Bronze Part Number
3/8"	C-015134
1/2"	C-015132
3/4"	C-015131
1"	C-015130

Air Tool Replacement Parts



ATP



The Performance Upgrade: Fix It To Last.

ATP's replacement air tool parts are known for unsurpassed quality. We have a complete line of superior quality parts for Chicago Pneumatic, Ingersoll Rand, Cleco, Top Cat, Sullair and of course ATP, Thor and every other major brand.

Our products have been manufactured in the U.S.A. since 1923, by world-class, certified machinists, and engineered at or above the most current OEM specifications and standards.

- Less Down Time
- Fewer Change Outs
- Reduce Maintenance Costs

Our parts fit right out of the box, each and every time. Repairing your tools with high quality ATP replacement parts gives you the confidence your tools will get the job done.

With over 10,000 OEM part numbers in stock, the next time you need quality replacement parts, demand ATP.



Air Tool Tune Up Kits



ATP Tune Up Kits

PART #	ICN	FITS MODELS
599-TKI	10787	IR599
C-10183	14763	CP 3440
2920P-TK2	16478	IR 2920P
2920B-TK2	16479	IR 2920
1720B-TK2	16658	IR 1720
1712P-TK3	16672	IR 1712
C-132252	16694	365
1710P-TK3	16695	IR 1710
1720P-TK2	16838	IR 1720
261-TK2	16895	IR 261
99V60-TK3	16993	IR 99V&H
2908P-TK2	19146	IR 2908
A-048065	19897	705
C-137164	21217	CP 9541
UW-75S-RK	21314	C.D.O.
CA-131501	22594	CP 797
2925-TK2	23242	IR 2925
2908-TK1	23667	IR 2908
C-101987	23778	CP 6120
3942-TK1	24621	IR 3942
3940-TK1	24622	IR 3940
3955-TK1	24632	IR 3955
ATP2059/2060-RK	25437	CLECO 2059/60
ATP2109/2110-RK	25438	CLECO 2109/10
ATP2119/2120-RK	25439	CLECO 2119/20
C-101091	5301	365
588-TK1	5341	IR 588
578-TK1	5583	IR 578
705-13H	92376	705
C-115811	92687	CP 611
C-118984	92688	CP 606
C-101089	92689	CP 610
C-119108	92814	CP 612
C-101614	92817	CP 614
C-101088	92827	CP 606
C-101077	92839	CP 20
2945-TK2	92994	IR 2945
2950-TK2	92995	IR 2950
2940-TK3	92996	IR 2940
2910-TK4	92997	IR 2910
2934-TK3	92998	IR 2934
P-059264	92999	9361

OZAT

Super Strength Impact Sockets,
Striking Wrenches and Accessories

WORLD'S MOST EXTENSIVE PRODUCT LINE

ELECTRO CHEMICALLY MACHINED (ECM)

LESS STRESS DESIGN



Why OZAT?

Electro Chemically Machined (ECM):

Electro Chemical Machining (ECM) is a process in which electrical and chemical energy sources are used for efficient and cost-effective metal removal. The process features:

- Fast machining of complex geometries and hard metals
- Smooth surface finishing
- Stress-free performance
- Absence of thermal strain
- High accuracy
- Automatic deburring

Sockets Are Fully Machined From Bar Stock

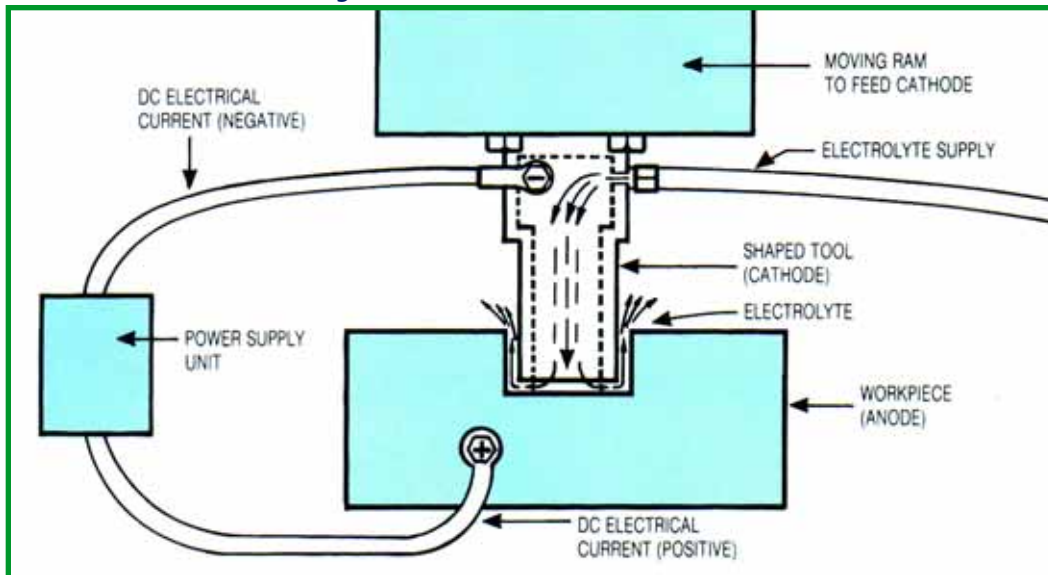

ECM Process Illustration

The cathode tool is shaped to provide the form desired in the work-piece. A low voltage is delivered by the power supply unit and an electrolyte is pumped under high pressure between the tool and the work-piece. A mechanically driven ram feeds the tool at a consistent rate into the work-piece to machine the desired shape or cavity.

Why OZAT?

Less Stress Design:

OZAT socket design is clearly superior to most other sockets available. Their state of the art electro-chemically machined process makes it possible for OZAT to produce all of their sockets in the **less-stress™** design illustrated below.

Without these special machining capabilities, cost of producing the preferred less-stress sockets becomes prohibitive. While other manufacturers, who use the normal broaching method to achieve the hex pattern in their sockets, may have to compromise in their selection of suitable steel, OZAT is able to specify the most perfectly matched material from which to manufacture the most durable and reliable sockets available.

The OZAT difference results in longer socket and fastener life and cost savings to the user.



OZAT VS. OTHER SOCKETS

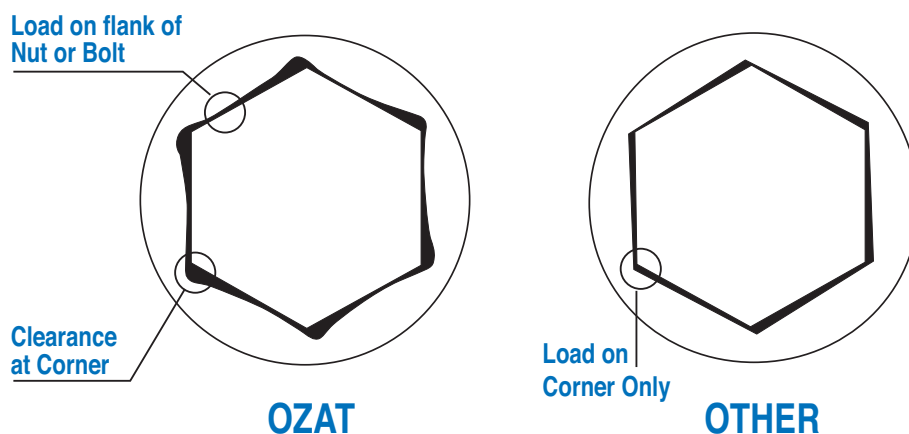

Availability:

ATP / OZAT Sockets are available in 1/2" through 3 1/2" Square Drive and in #4 and #5 Spline sizes, in 4 point, 6 point, 8 point, 12 point, Standard depth, Deep length, Thin walls, Hex bit, "In-Star" type bits, Magnetic bits, Railroad sockets and Torsion bars.

Custom Sockets quoted upon request.

Statement of Warranty:

The OZAT warranty provides for free replacement, to the original purchaser, of any qualifying socket found to be defective in either material or workmanship, as indicated by breakage or premature wear. Determination of free replacement will be made after examination by ATP. Impact sockets, by their application, are subject to extreme stresses. Therefore special application sockets such as thinwall, hex driver, In-Star driver, and accessories are specifically excluded from the replacement warranty.

Products returned to ATP for warranty consideration must be shipped prepaid, with an ATP returned goods authorization (RGA) number issued by the customer service department.

ATP/OZAT impact sockets and accessories are available exclusively through leading industrial distributors nationwide.

For the name of a distributor in your area contact ATP at 1-800-245-1148.

OZAT Contents

1/2 Inch Square Drive	37
Six Point Impact Sockets	
In-star Drivers & Sockets	
Hex Driver and 12 Point Sockets	
Ret Rings	
Power Line Utility Sockets	
5/8 Inch Square Drive	44
Six Point Impact Sockets	
Accessories	
3/4 Inch Square Drive	46
Six Point Impact Sockets	
BUDD Wheel Sockets	
Hex Driver Sockets	
Double Square Impact Sockets	
12 Point Sockets	
Accessories	
Railroad Sockets	53
1 Inch Square Drive	54
Six Point Impact Sockets	
Hex Driver Sockets	
Double Square Impact Sockets	
BUDD Wheel Sockets	
12 Point Sockets	
Accessories	
1-1/2 Inch Square Drive	61
Six Point Impact Sockets	
12 Point Sockets	
Accessories	
2-1/2 Inch Square Drive	66
Six Point Impact Sockets	
Accessories	
3-1/2 Inch Square Drive	70
Six Point Impact Sockets	
Accessories	
#5 Spline Drive	72
#4 Spline Sockets & Universal Joint	72
Six Point Impact Sockets	74
BUDD Wheel Sockets	
Accessories for #5 Spline Drive	
Flat Striking Wrenches (12 Point Opening)	75
Offset Striking Wrenches (12 Point Opening)	77
Striking Wrench Adapter	77
Strike Force Mark Safety Wrenches (12 Point Opening)	78
Torque Multipliers	79
Request for Quote (Special Socket Order)	80



STANDARD FRACTIONAL SIZES

SIZE	PART#	D1	D2	L	T	C
3/8	Z-0806	0.630	0.984	1.482	0.157	0.595
7/16	Z-0807	0.748	0.984	1.482	0.236	0.595
1/2	Z-0808	0.787	0.984	1.482	0.236	0.674
9/16	Z-0809	0.866	0.984	1.482	0.276	0.674
5/8	Z-0810	0.984	1.181	1.482	0.315	0.753
11/16	Z-0811	1.102	1.181	1.482	0.354	0.753
3/4	Z-0812	1.102	1.181	1.482	0.335	0.753
13/16	Z-0813	1.181	1.181	1.482	0.433	0.832
7/8	Z-0814	1.181	1.181	1.482	0.512	0.910
15/16	Z-0815	1.378	1.181	1.482	0.512	0.910
1	Z-0816	1.496	1.181	1.482	0.512	0.950
1-1/16	Z-0817	1.496	1.181	1.950	0.512	0.950
1-1/8	Z-0818	1.614	1.181	1.560	0.643	1.107
1-3/16	Z-0819	1.614	1.181	1.950	0.643	1.107
1-1/4	Z-0820	1.732	1.378	1.560	0.669	1.107
1-5/16	Z-0821	1.732	1.378	1.677	0.748	1.186
1-3/8	Z-0822	1.929	1.378	1.560	0.748	1.265
1-7/16	Z-0823	1.929	1.732	1.950	0.748	1.265
1-1/2	Z-0824	2.047	1.732	1.950	0.846	1.344

DEEP FRACTIONAL SIZES

SIZE	PART#	D1	D2	L	T	C
3/8	Z-0806L	0.6307	0.984	3.042	0.157	2.721
7/16	Z-0807L	0.748	0.984	3.042	0.236	2.721
1/2	Z-0808L	0.787	0.984	3.042	0.236	2.721
9/16	Z-0809L	0.866	0.984	3.042	0.276	2.721
5/8	Z-0810L	0.984	1.181	3.042	0.315	2.721
11/16	Z-0811L	1.102	1.181	3.042	0.354	2.721
3/4	Z-0812L	1.102	1.181	3.042	0.335	2.721
13/16	Z-0813L	1.181	1.181	3.042	0.433	2.721
7/8	Z-0814L	1.181	1.181	3.042	0.512	2.721
15/16	Z-0815L	1.378	1.181	3.042	0.512	2.721
1	Z-0816L	1.496	1.181	3.042	0.512	2.721
1-1/16	Z-0817L	1.496	1.181	3.042	0.512	2.721
1-1/8	Z-0818L	1.614	1.181	3.042	0.643	2.721
1-3/16	Z-0819L	1.614	1.181	3.042	0.643	2.721
1-1/4	Z-0820L	1.732	1.378	3.042	0.669	2.721
1-5/16	Z-0821L	1.732	1.378	3.042	0.748	2.721
1-3/8	Z-0822L	1.929	1.378	3.042	0.748	2.721
1-7/16	Z-0823L	1.929	1.732	3.042	0.748	2.721
1-1/2	Z-0824L	2.047	1.732	3.042	0.846	2.721

STANDARD FRACTIONAL THINWALL

SIZE	PART#	D1	D2	L	T	C
9/16	Z-0809T	0.866	0.984	1.482	0.551	0.700
5/8	Z-0810T	0.984	0.984	1.482	0.551	0.750
11/16	Z-0811T	0.984	0.984	1.482	0.551	0.750
3/4	Z-0812T	1.102	1.181	1.482	0.551	0.750
13/16	Z-0813T	1.102	1.181	1.482	0.551	0.780
7/8	Z-0814T	1.181	1.181	1.482	0.551	0.780
15/16	Z-0815T	1.299	1.181	1.482	0.551	0.810

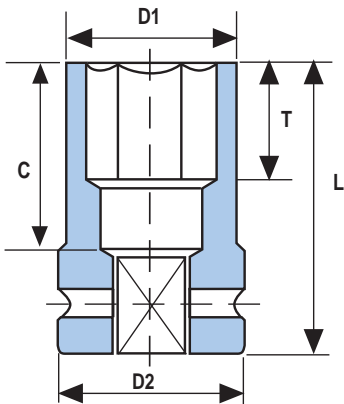
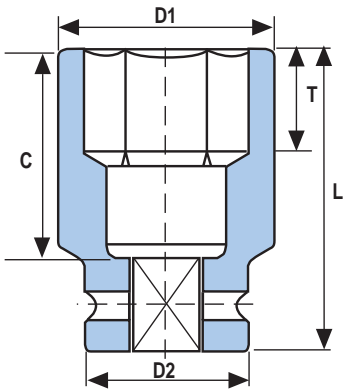
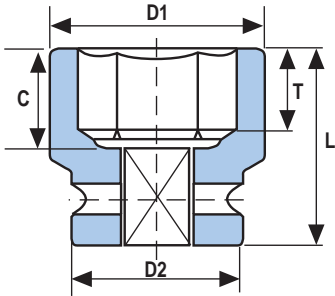

Quality OZAT 1/2" Drive impact sockets are preferred in many industrial applications where long wearing sockets are required for severe applications. From assembly lines to plant maintenance to busy tire shops, OZAT sockets reduce cost and downtime.

1/2" SQUARE DRIVE

SIX POINT IMPACT SOCKETS

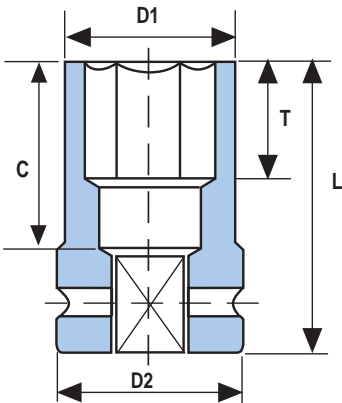
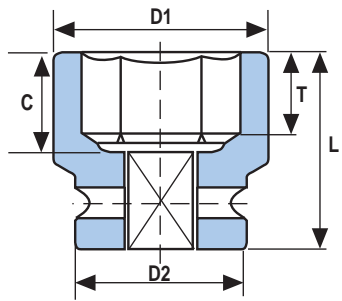
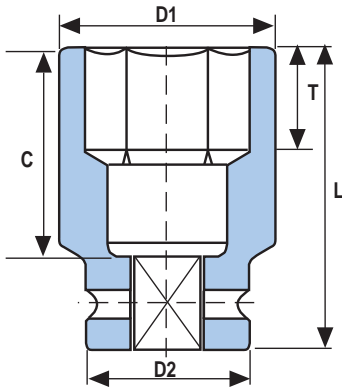

DEEP FRACTIONAL THINWALL

SIZE	PART#	D1	D2	L	T	C
9/16	Z-0809LT	0.866	0.984	3.042	0.551	2.721
5/8	Z-0810LT	0.984	0.984	3.042	0.551	2.721
11/16	Z-0811LT	0.984	0.984	3.042	0.551	2.721
3/4	Z-0812LT	1.102	1.181	3.042	0.551	2.721
13/16	Z-0813LT	1.102	1.181	3.042	0.551	2.721
7/8	Z-0814LT	1.181	1.181	3.042	0.551	2.721
15/16	Z-0815LT	1.299	1.181	3.042	0.551	2.721

STANDARD METRIC SIZES

SIZE	PART#	D1	D2	L	T	C
8	Z-08M8	15	25	38	4	15
9	Z-08M9	16	25	38	4	15
10	Z-08M10	17	25	38	5	15
11	Z-08M11	19	21	38	5	15
12	Z-08M12	20	25	38	6	17
13	Z-08M13	21	25	38	6	17
14	Z-08M14	22	25	38	7	17
15	Z-08M15	24	30	38	7	19
16	Z-08M16	25	30	38	7	19
17	Z-08M17	26	30	38	9	19
18	Z-08M18	28	30	38	9	19
19	Z-08M19	28	30	38	9.5	19
20	Z-08M20	30	30	38	10	21
21	Z-08M21	30	30	38	10	21
22	Z-08M22	33	30	38	10	21
23	Z-08M23	35	30	38	12	23
24	Z-08M24	35	30	45	12	23
25	Z-08M25	35	30	45	13	24
26	Z-08M26	38	5	50	13	24
27	Z-08M27	38	35	50	13	24
28	Z-08M28	38	35	50	14	25
29	Z-08M29	41	35	50	14	28
30	Z-08M30	41	35	50	16.5	28
31	Z-08M31	44	35	50	16.5	28
32	Z-08M32	44	35	50	16.5	28
33	Z-08M33	44	35	50	17	28
34	Z-08M34	49	35	46	17	30
35	Z-08M35	49	35	50	19	31
36	Z-08M36	49	44	50	19	31
37	Z-08M37	52	44	47	19	31
38	Z-08M38	52	44	50	22	34

STANDARD METRIC THINWALL

SIZE	PART#	D1	D2	L	T	C
13	Z-08M13T	21	25	38	6	18
14	Z-08M14T	22	25	38	7	18
15	Z-08M15T	24	30	38	7	19
16	Z-08M16T	25	30	38	7	19
17	Z-08M17T	25	30	38	9	19
18	Z-08M18T	25	30	38	9	19
19	Z-08M19T	28	30	38	9	19
20	Z-08M20T	28	30	38	10	20
21	Z-08M21T	30	30	38	10	20
22	Z-08M22T	30	30	38	10	20
23	Z-08M23T	33	30	38	12	20
24	Z-08M24T	33	30	45	12	20

SIX POINT IMPACT SOCKETS

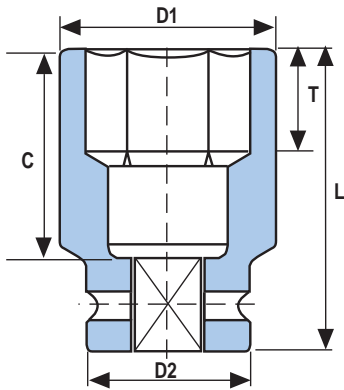

DEEP METRIC SIZES

SIZE	PART#	D1	D2	L	T	C
8	Z-08M8L	15	25	78	4	69
9	Z-08M9L	16	25	78	4	69
10	Z-08M10L	17	25	78	5	69
11	Z-08M11L	19	25	78	5	69
12	Z-08M12L	20	25	78	6	69
13	Z-08M13L	21	25	78	6	69
14	Z-08M14L	22	25	78	7	69
15	Z-08M15L	24	30	78	7	69
16	Z-08M16L	25	30	78	7	69
17	Z-08M17L	26	30	78	9	69
18	Z-08M18L	28	30	78	9	69
19	Z-08M19L	28	30	78	9.5	69
20	Z-08M20L	30	30	78	10	69
21	Z-08M21L	30	30	78	10	69
22	Z-08M22L	33	30	78	10	69
23	Z-08M23L	35	30	78	12	69
24	Z-08M24L	35	30	78	12	69
25	Z-08M25L	35	30	78	13	69
26	Z-08M26L	38	35	78	13	69
27	Z-08M27L	38	35	78	13	69
28	Z-08M28L	38	35	78	14	69
29	Z-08M29L	41	35	78	14	69
30	Z-08M30L	41	35	78	16.5	69
31	Z-08M31L	44	35	78	16.5	69
32	Z-08M32L	44	35	78	16.5	69
33	Z-08M33L	44	35	78	17	69
34	Z-08M34L	49	35	78	17	69
35	Z-08M35L	49	35	78	19	69
36	Z-08M36L	49	44	78	19	69
37	Z-08M37L	52	44	78	19	69
38	Z-08M38L	52	44	78	22	69

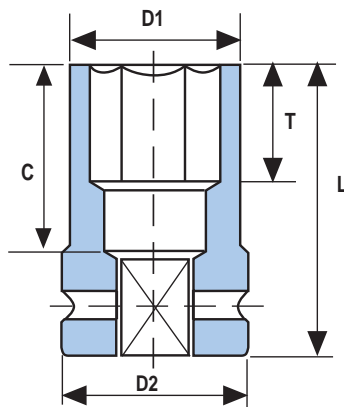

DEEP METRIC THINWALL

SIZE	PART#	D1	D2	L	T	C
13	Z-08M13LT	21	25	78	6	69
14	Z-08M14LT	22	25	78	7	69
15	Z-08M15LT	24	30	78	7	69
16	Z-08M16LT	25	30	78	7	69
17	Z-08M17LT	25	30	78	9	69
18	Z-08M18LT	25	30	78	9	69
19	Z-08M19LT	28	30	78	9	69
20	Z-08M20LT	28	30	78	10	69
21	Z-08M21LT	30	30	78	10	69
22	Z-08M22LT	30	30	78	10	69
23	Z-08M23LT	33	30	78	12	69
24	Z-08M24LT	33	30	78	12	69

1/2" SQUARE DRIVE

HEX DRIVER SOCKETS

Bit Holders

PART#	DESCRIPTION
Z-08H11	1/2" Sq. x 11mm Hex Bit Holders
Z-08H16	1/2" Sq. x 16mm Hex Bit Holders

IMPACT SOCKETS FOR IN-STAR FASTENERS

NOMINAL OPENING		D1	D2	L	t min	Weight
TORX®	CATALOG No.	mm	mm	mm	mm	gr
E10	Z-08E10	15.0	25	38	9.0	85
E11	Z-08E11	15.5	25	38	9.0	85
E12	Z-08E12	16.0	25	38	10.0	91
E14	Z-08E14	18.5	25	38	12.0	91
E16	Z-08E16	20.0	25	38	12.0	95
E18	Z-08E18	22.0	25	38	12.0	95
E20	Z-08E20	25.0	30	38	13.0	140
E22	Z-08E22	26.5	30	45	15.0	158
E24	Z-08E24	28.5	30	45	17.0	161

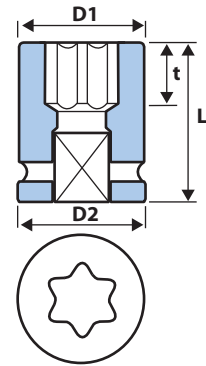

SOCKET DRIVERS FOR IN-STAR FASTENERS

NOMINAL OPENING		D2	L	t min	Weight
TORX®	CATALOG No.	mm	mm	mm	gr
T30	Z-08T30	25	57	3.19	110
T40	Z-08T40	25	57	3.30	110
T50	Z-08T50	25	57	4.57	110
T55	Z-08T55	25	57	5.08	110
T60	Z-08T60	30	60	7.62	160
T70	Z-08T70	30	60	8.89	170

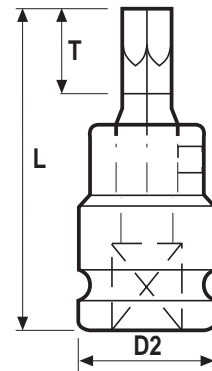

®TORX BIT is a registered trademark of Cam Car

Replacement Instar TORX Bits

PART#	DESCRIPTION
HT30	11mm Hex x 30
HT40	11mm Hex x 40
HT50	11mm Hex x 50
HT55	16mm Hex x 55
HT60	16mm Hex x 60
HT70	16mm Hex x 70

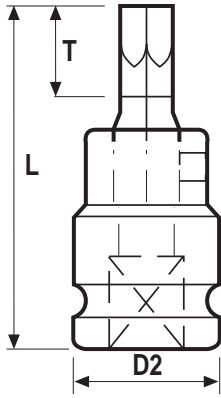

FRACTIONAL SIZES

SIZE	PART#	D2	L	T
1/8	Z-0802H	0.984	1.716	0.748
5/32	Z-08005H	0.984	1.716	0.748
3/16	Z-0803H	0.984	1.716	0.748
7/32	Z-08007H	0.984	1.716	0.748
1/4	Z-0804H	0.984	1.716	0.748
5/16	Z-0805H	0.984	1.716	0.748
3/8	Z-0806H	0.984	1.833	0.866
7/16	Z-0807H	0.984	1.950	0.984
1/2	Z-0808H	1.181	1.950	0.984
9/16	Z-0809H	1.181	1.950	0.984
5/8	Z-0810H	1.181	1.950	0.984

Note: 1 Piece Construction

METRIC SIZES

SIZE	PART#	D2	L	T
3	Z-08M3H	25	44	19
4	Z-08M4H	25	44	19
5	Z-08M5H	25	44	19
6	Z-08M6H	25	44	19
8	Z-08M8H	25	44	19
10	Z-08M10H	25	47	22
12	Z-08M12H	30	50	25
14	Z-08M14H	30	50	25
17	Z-08M17H	30	50	25
19	Z-08M19H	33	50	25

Note: 1 Piece Construction

2 PART INHEX

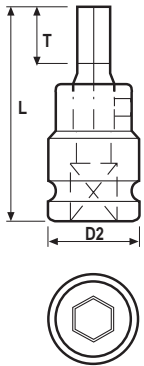

NOMINAL OPENING		CATALOG No.	D2 mm	L mm	T mm	Weight gr
mm	A/F Inch					
	1/8"	Z-0802V	25	54	6	90
	5/32"	Z-08025V	25	54	6	90
	3/16"	Z-0803V	25	54	8	90
	7/32"	Z-08035V	25	54	9	90
	1/4"	Z-0804V	25	57	12	100
	5/16"	Z-0805V	25	57	12	100
	3/8"	Z-0806V	25	57	16	100
	7/16"	Z-0807V	25	57	18	100
	1/2"	Z-0808V	30	57	19	150
	9/16"	Z-0809V	30	57	21	150
	5/8"	Z-0810V	30	57	24	150
3		Z-08M03V	25	54	5	90
4		Z-08M04V	25	54	6	90
5		Z-08M05V	25	54	8	90
6		Z-08M06V	25	54	9	100
8		Z-08M08V	25	57	12	100
10		Z-08M10V	25	57	16	100
12		Z-08M12V	30	57	18	150
14		Z-08M14V	30	57	21	150
17		Z-08M17V	30	57	26	150
19		Z-08M19V	30	72	26	150

Note: 2 Piece Construction

Replacement Hex Bits

PART#
H02
H025
H03
H035
H04
H05
H06
H07
H08
H09
H10
HM03
HM04
HM05
HM06
HM08
HM10
HM12
HM14
HM17
HM19

12 POINT IMPACT SOCKETS

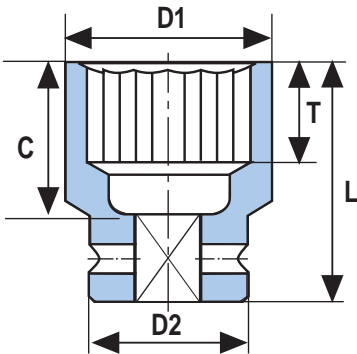

12 POINT IMPACT SOCKETS

NOMINAL OPENING		CATALOG No.	D1 mm	D2 mm	L mm	tmin mm	Weight gr
mm	A/F Inch						
19	3/4"	DH-0812M19	28	30	38	9.5	130
	13/16"	DH-0813	30	30	38	11	130
	7/8"	DH-0814	32	32	38	13	140
	15/16"	DH-0815	35	35	38	13.0	160
	1"	DH-0816	38	35	38	13.0	200
27	1/16"	DH-0817M27	38	35	50	13.0	200
	1-1/8"	DH-0818	41	35	40	16.5	290
30	1 3/16"	DH-0819M30	41	35	50	16.5	290
	1-1/4"	DH-0820	44	35	40	17.0	350
	1-5/16"	DH-0821	49	35	43	19.0	370
35	1-3/8"	DH-0822M35	49	35	50	19.0	370
	1-7/16"	DH-0823	49	44	50	19.0	370
38	1-1/2"	DH-0824M38	52	44	50	22.0	400

1/2" SQUARE DRIVE

ACCESSORIES

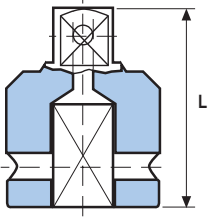

ADAPTERS

PART#	FEMALE	MALE	L
A0810	1/2	5/8	1.380
A0812	1/2	3/4	1.690

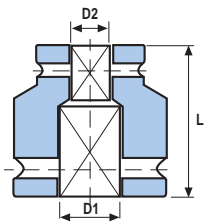

DOUBLE ENDED FEMALE ADAPTERS

PART#	D1	D2	L
AN0808	1/2	1/2	1.290
AN1008	1/2	5/8	1.610
AN1208	1/2	3/4	1.930



UNIVERSAL JOINT

SIZE	PART#
1/2	U0808

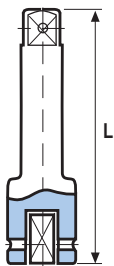

EXTENSIONS

PART#	L
E0803	3
E0805	5
E0810	10

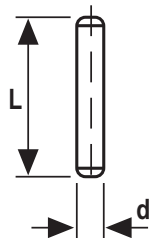
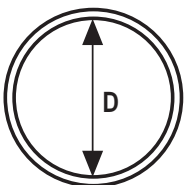

RETAINING PINS AND RINGS

SQUARE DRIVE	THROUGH HEX SIZE	PIN #	RING#	d	L	D
1/2	9/16 - 14mm	P0825	R0825	.117	.780	.741
1/2	1-3/16 - 30mm	P0830	R0830	.117	.975	.936
1/2	Above 1-3/16	P0835	R0835	.117	1.170	1.170

1/2" SQUARE DRIVE

UTILITY SOCKETS

UTILITY SOCKETS (POWER LINE SOCKETS)

Z-081315S5 - 13/16" x 15/16"

Z-081618S5 - 1" X 1-1/8"

Specifically designed for hydraulic wrenches and impact wrenches

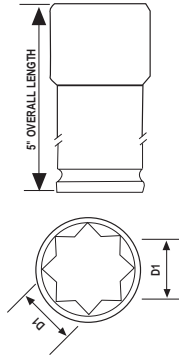

SQUARE DRIVE ADAPTOR

DOUBLE ENDED MALE ADAPTORS 7/16" HEX TO 1/2" SQUARE

PART#	D1	L
S-084874-HD	0.661	2.25



TIRE SHOP FLIP SOCKETS

PART#	SIZE
D-1213	3/4 X 13/16
D-19M21	19MM X 21MM

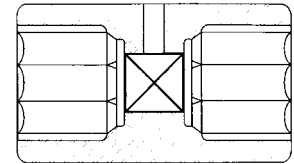

RETAINING RING®

Ret Rings are tool accessories used to attach impact sockets to the square drive anvil. The ret ring is a one piece design socket retainer with a steel insert encapsulated to reinforce a stress point between the socket and anvil.

Specific application part numbers have been provided for each socket type, starting with 3/4" drive.



5/8" SQUARE DRIVE

SIX POINT IMPACT SOCKETS

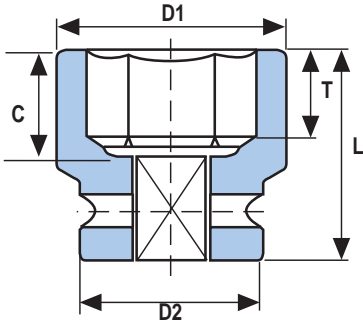

STANDARD FRACTIONAL SIZES

SIZE	PART#	D1	D2	L	T	C
1/2	Z-1008	0.906	1.378	1.365	0.236	0.753
9/16	Z-1009	0.945	1.378	1.365	0.275	0.753
5/8	Z-1010	1.024	1.378	1.365	0.315	0.753
11/16	Z-1011	1.142	1.378	1.482	0.354	0.871
3/4	Z-1012	1.220	1.378	1.482	0.375	0.871
13/16	Z-1013	1.299	1.378	1.482	0.433	0.871
7/8	Z-1014	1.378	1.378	1.560	0.512	0.950
15/16	Z-1015	1.378	1.378	1.560	0.512	0.950
1	Z-1016	1.496	1.378	1.600	0.512	0.989
1-1/16	Z-1017	1.614	1.378	1.600	0.512	0.989
1-1/8	Z-1018	1.614	1.378	1.638	0.650	1.147
1-3/16	Z-1019	1.732	1.378	1.638	0.650	1.147
1-1/4	Z-1020	1.732	1.378	1.794	0.669	1.186
1-5/16	Z-1021	1.929	1.378	1.911	0.748	1.265
1-3/8	Z-1022	1.929	1.378	1.989	0.748	1.383
1-7/16	Z-1023	2.047	1.732	1.989	0.748	1.383
1-1/2	Z-1024	2.126	1.732	1.989	0.866	1.383

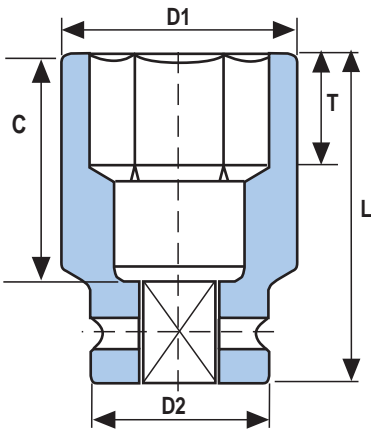

DEEP FRACTIONAL SIZES

SIZE	PART#	D1	D2	L	T	C
1/2	Z-1008L	0.906	1.378	3.465	0.236	2.840
9/16	Z-1009L	0.945	1.378	3.465	0.275	2.840
5/8	Z-1010L	1.024	1.378	3.465	0.315	2.840
11/16	Z-1011L	1.142	1.378	3.465	0.354	2.840
3/4	Z-1012L	1.220	1.378	3.465	0.375	2.840
13/16	Z-1013L	1.299	1.378	3.465	0.433	2.840
7/8	Z-1014L	1.378	1.378	3.465	0.512	2.840
15/16	Z-1015L	1.378	1.378	3.465	0.512	2.840
1	Z-1016L	1.496	1.378	3.465	0.512	2.840
1-1/16	Z-1017L	1.614	1.378	3.465	0.512	2.840
1-1/8	Z-1018L	1.614	1.378	3.465	0.650	2.840
1-3/16	Z-1019L	1.732	1.378	3.465	0.650	2.840
1-1/4	Z-1020L	1.732	1.378	3.465	0.669	2.840
1-5/16	Z-1021L	1.929	1.378	3.465	0.748	2.840
1-3/8	Z-1022L	1.929	1.378	3.465	0.748	2.840
1-7/16	Z-1023L	2.047	1.732	3.465	0.748	2.840
1-1/2	Z-1024L	2.126	1.732	3.465	0.866	2.840

Why 5/8" drive? This unusual drive size was originally introduced in the 1930's to eliminate the "disappearing socket syndrome". It remains popular in several applications today for the heavier wall thickness than comparable 1/2" drive sockets.

STANDARD METRIC SIZES

SIZE	PART#	D1	D2	L	T	C
13	Z-10M13	23	35	35	6	19
14	Z-10M14	24	35	35	7	19
15	Z-10M15	26	35	35	7	19
16	Z-10M16	26	35	35	7	19
17	Z-10M17	28	35	38	9	22
18	Z-10M18	30	35	38	9	22
19	Z-10M19	31	35	38	9.5	22
20	Z-10M20	32	35	38	10	22
21	Z-10M21	33	35	38	10	22
22	Z-10M22	35	35	40	10	24
23	Z-10M23	35	35	40	12	24
24	Z-10M24	35	35	40	12	24
25	Z-10M25	38	35	41	13	25
26	Z-10M26	38	35	41	13	25
27	Z-10M27	41	35	42	13	25
28	Z-10M28	41	35	42	14	26
29	Z-10M29	41	35	45	14	29
30	Z-10M30	44	35	45	16.5	29
31	Z-10M31	44	35	46	16.5	42
32	Z-10M32	44	35	47	16.5	42
33	Z-10M33	44	35	47	17	31
34	Z-10M34	49	35	50	17	34
35	Z-10M35	49	35	51	19	35
36	Z-10M36	52	35	51	19	35
37	Z-10M37	54	44	51	19	35
38	Z-10M38	54	44	51	22	35

DEEP METRIC SIZES

SIZE	PART#	D1	D2	L	T	C
13	Z-10M13L	23	35	88	6	72
14	Z-10M14L	24	35	88	7	72
15	Z-10M15L	26	35	88	7	72
16	Z-10M16L	26	35	88	7	72
17	Z-10M17L	28	35	88	9	72
18	Z-10M18L	30	35	88	9	72
19	Z-10M19L	31	35	88	9.5	72
20	Z-10M20L	32	35	88	10	72
21	Z-10M21L	33	35	88	10	72
22	Z-10M22L	35	35	88	10	72
23	Z-10M23L	35	35	88	12	72
24	Z-10M24L	35	35	88	12	72
25	Z-10M25L	38	35	88	13	72
26	Z-10M26L	38	35	88	13	72
27	Z-10M27L	41	35	88	13	72
28	Z-10M28L	41	35	88	14	72
29	Z-10M29L	41	35	88	14	72
30	Z-10M30L	44	35	88	16.5	72
31	Z-10M31L	44	35	88	16.5	72
32	Z-10M32L	44	35	88	16.5	72
33	Z-10M33L	44	35	88	17	72
34	Z-10M34L	49	35	88	17	72
35	Z-10M35L	49	35	88	19	72
36	Z-10M36L	52	35	88	19	72
37	Z-10M37L	54	44	88	19	72
38	Z-10M38L	54	44	88	22	72

ACCESSORIES

UNIVERSAL JOINT

SIZE	PART#
5/8	U1010



ADAPTERS

PART#	FEMALE	MALE	L
A1008	5/8	1/2	1.900
A1012	5/8	3/4	1.770

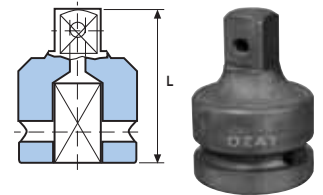

RETAINING PINS AND RINGS

SQUARE DRIVE	THROUGH HEX SIZE	PIN #	RING#	d	L	D
5/8	1-3/16 - 30mm	P1035	R1035	.117	1.070	1.092
5/8	Above 1-3/16	P1044	R1044	.117	1.521	1.443

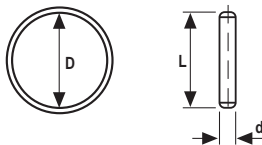

DOUBLE ENDED FEMALE ADAPTERS

PART#	D1	D2	L
AN1008	5/8	1/2	1.299
AN1010	5/8	5/8	1.378
AN1012	5/8	3/4	1.969

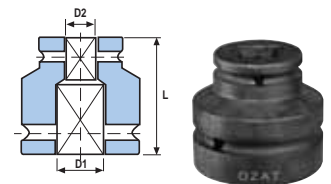

DOUBLE ENDED MALE EXTENSIONS

PART#	D1	L
Z1002	0.830	2
Z1003	0.830	3
Z1006	0.830	6
Z1012	0.830	12

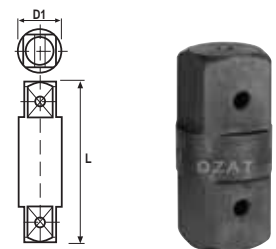

3/4" SQUARE DRIVE

SIX POINT IMPACT SOCKETS

STANDARD FRACTIONAL SIZES

SIZE	PART#	D1	D2	L	T	C	RET RING
1/2	Z-1208	0.945	1.732	1.755	0.236	0.772	10032S
9/16	Z-1209	0.984	1.732	1.755	0.276	0.772	10032S
5/8	Z-1210	1.102	1.732	1.755	0.315	0.772	10032S
11/16	Z-1211	1.142	1.732	1.755	0.354	0.772	10032S
3/4	Z-1212	1.260	1.732	1.755	0.372	0.772	10032S
13/16	Z-1213	1.378	1.732	1.794	0.433	0.890	10032S
7/8	Z-1214	1.496	1.732	1.794	0.512	0.890	10032S
15/16	Z-1215	1.575	1.732	1.794	0.512	0.890	10032S
1	Z-1216	1.614	1.732	1.794	0.512	0.890	10032S
1-1/16	Z-1217	1.732	1.732	2.028	0.512	1.047	10032S
1-1/8	Z-1218	1.732	1.732	2.028	0.650	1.047	10034S
1-3/16	Z-1219	1.732	1.732	2.028	0.650	1.047	18708S
1-1/4	Z-1220	1.929	1.732	2.028	0.650	1.047	18708S
1-5/16	Z-1221	1.929	1.732	2.145	0.748	1.165	18708S
1-3/8	Z-1222	2.047	1.732	2.145	0.748	1.165	18708S
1-7/16	Z-1223	2.047	1.732	2.184	0.748	1.205	18708S
1-1/2	Z-1224	2.126	1.732	2.301	0.866	1.283	18708S
1-9/16	Z-1225	2.244	1.732	2.301	0.866	1.283	18708S
1-5/8	Z-1226	2.244	1.732	2.301	0.866	1.283	18708S
1-11/16	Z-1227	2.480	1.732	2.496	0.984	1.441	18708S
1-3/4	Z-1228	2.480	1.732	2.496	0.995	1.480	18708S
1-13/16	Z-1229	2.638	1.732	2.496	0.995	1.480	18708S
1-7/8	Z-1230	2.638	2.126	2.613	1.062	1.598	18708S
1-15/16	Z-1231	2.756	2.126	2.613	1.062	1.598	18708S
2	Z-1232	2.874	2.126	2.613	1.062	1.598	18708S
2-1/16	Z-1233	2.874	2.126	2.769	1.181	1.756	18708S
2-1/8	Z-1234	2.874	2.126	2.769	1.181	1.795	18708S
2-3/16	Z-1235	3.071	2.126	2.886	1.260	1.795	18708S
2-1/4	Z-1236	3.228	2.126	2.925	1.299	1.913	18708S
2-5/16	Z-1237	3.228	2.126	2.925	1.299	1.953	18708S
2-3/8	Z-1238	3.228	2.126	2.925	1.378	1.953	18708S

DEEP FRACTIONAL SIZES

SIZE	PART#	D1	D2	L	T	C	RET RING
1/2	Z-1208L	0.945	1.732	3.510	0.236	2.543	10032S
9/16	Z-1209L	0.984	1.732	3.510	0.276	2.543	10032S
5/8	Z-1210L	1.102	1.732	3.510	0.315	2.543	10032S
11/16	Z-1211L	1.142	1.732	3.510	0.354	2.543	10032S
3/4	Z-1212L	1.260	1.732	3.510	0.372	2.543	10032S
13/16	Z-1213L	1.378	1.732	3.510	0.433	2.543	10032S
7/8	Z-1214L	1.496	1.732	3.510	0.512	2.543	10032S
15/16	Z-1215L	1.575	1.732	3.510	0.512	2.543	10032S
1	Z-1216L	1.614	1.732	3.510	0.512	2.543	10032S
1-1/16	Z-1217L	1.732	1.732	3.510	0.512	2.543	10032S
1-1/8	Z-1218L	1.732	1.732	3.510	0.650	2.543	10034S
1-3/16	Z-1219L	1.732	1.732	3.510	0.650	2.543	18708S
1-1/4	Z-1220L	1.929	1.732	3.510	0.669	2.543	18708S
1-5/16	Z-1221L	1.929	1.732	3.510	0.748	2.543	18708S
1-3/8	Z-1222L	2.047	1.732	3.510	0.748	2.543	18708S
1-7/16	Z-1223L	2.047	1.732	3.510	0.748	2.543	18708S
1-1/2	Z-1224L	2.126	1.732	3.510	0.866	2.543	18708S
1-9/16	Z-1225L	2.244	1.732	3.510	0.866	2.543	18708S
1-5/8	Z-1226L	2.244	1.732	3.510	0.866	2.543	18708S
1-11/16	Z-1227L	2.480	1.732	3.510	0.984	2.543	18708S
1-3/4	Z-1228L	2.480	1.732	3.510	0.995	2.543	18708S
1-13/16	Z-1229L	2.638	1.732	3.510	0.995	2.543	18708S
1-7/8	Z-1230L	2.638	2.126	3.510	1.062	2.543	18708S
1-15/16	Z-1231L	2.756	2.126	3.510	1.062	2.543	18708S
2	Z-1232L	2.874	2.126	3.510	1.062	2.543	18708S
2-1/16	Z-1233L	2.874	2.126	3.666	1.181	2.701	18708S
2-1/8	Z-1234L	2.874	2.126	3.666	1.181	2.740	18708S
2-3/16	Z-1235L	3.071	2.126	3.666	1.260	2.740	18708S
2-1/4	Z-1236L	3.228	2.126	3.822	1.299	2.858	18708S
2-5/16	Z-1237L	3.228	2.126	3.822	1.299	2.898	18708S
2-3/8	Z-1238L	3.228	2.126	3.822	1.378	2.898	18708S

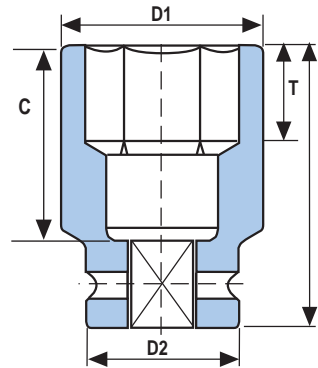
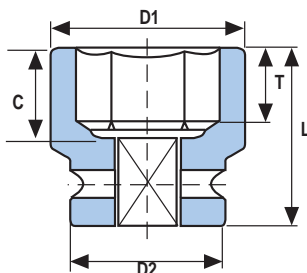

OZAT 3/4" drive sockets (and larger) are also available by special order as Spark Resistant for use in mines, chemical plants, grain processors and anywhere explosive conditions exist.

STANDARD METRIC SIZES



SIZE	PART#	D1	D2	L	T	C	RET RING
13	Z-12M13	25	44	45	6	20	10032S
14	Z-12M14	25	44	45	7	20	10032S
15	Z-12M15	28	44	45	7	20	10032S
16	Z-12M16	29	44	45	7	20	10032S
17	Z-12M17	29	44	45	9	20	10032S
18	Z-12M18	32	44	45	9.5	20	10032S
19	Z-12M19	32	44	45	9.5	20	10032S
20	Z-12M20	35	44	46	10	21	10032S
21	Z-12M21	35	44	46	10	21	10032S
22	Z-12M22	38	44	46	10	21	10032S
23	Z-12M23	38	44	46	12	21	10032S
24	Z-12M24	40	44	46	12	21	10032S
25	Z-12M25	41	44	46	13	21	10032S
26	Z-12M26	41	44	46	13	21	10032S
27	Z-12M27	41	44	48	13	23	10032S
28	Z-12M28	44	44	48	14	23	10032S
29	Z-12M29	44	44	52	14	27	10032S
30	Z-12M30	44	44	52	16.5	27	10032S
31	Z-12M31	49	44	52	16.5	27	10032S
32	Z-12M32	49	44	52	16.5	27	10034S
33	Z-12M33	49	44	55	17	30	10034S
34	Z-12M34	52	44	55	17	30	10034S
35	Z-12M35	52	44	55	19	30	10034S
36	Z-12M36	52	44	56	19	31	10034S
37	Z-12M37	54	44	56	19	31	10034S
38	Z-12M38	54	44	59	22	34	10034S
39	Z-12M39	57	44	59	21.5	34	18708S
40	Z-12M40	57	44	59	21.5	34	18708S
41	Z-12M41	57	44	59	22	34	18708S
42	Z-12M42	60	44	59	21.5	34	18708S
43	Z-12M43	63	44	64	25	39	18708S
44	Z-12M44	63	44	64	21.5	39	18708S
45	Z-12M45	63	44	64	21.5	39	18708S
46	Z-12M46	67	44	64	25.5	39	18708S
47	Z-12M47	67	54	64	23.5	39	18708S
48	Z-12M48	67	54	67	23.5	42	18708S
49	Z-12M49	70	54	67	27	42	18708S
50	Z-12M50	70	54	67	23.5	42	18708S
51	Z-12M51	73	54	67	27	42	18710S
52	Z-12M52	73	54	70	27	45	18710S
54	Z-12M54	78	54	71	30	46	18710S
55	Z-12M55	78	54	71	27	46	18710S
56	Z-12M56	78	54	74	28	49	18710S
57	Z-12M57	82	54	75	33	50	18710S
58	Z-12M58	82	54	75	28	50	18710S
59	Z-12M59	82	54	75	33	50	18710S
60	Z-12M60	82	54	75	28	50	18710S
61	Z-12M61	86	54	75	28	50	18710S

DEEP METRIC SIZES



SIZE	PART#	D1	D2	L	T	C	RET RING
13	Z-12M13L	25	44	90	6	65	10032S
14	Z-12M14L	25	44	90	7	65	10032S
15	Z-12M15L	28	44	90	7	65	10032S
16	Z-12M16L	29	44	90	7	65	10032S
17	Z-12M17L	29	44	90	9	65	10032S
18	Z-12M18L	32	44	90	9	65	10032S
19	Z-12M19L	32	44	90	9.5	65	10032S
20	Z-12M20L	35	44	90	10	65	10032S
21	Z-12M21L	35	44	90	10	65	10032S
22	Z-12M22L	38	44	90	10	65	10032S
23	Z-12M23L	38	44	90	12	65	10032S
24	Z-12M24L	40	44	90	12	65	10032S
25	Z-12M25L	41	44	90	13	65	10032S
26	Z-12M26L	41	44	90	13	65	10032S
27	Z-12M27L	41	44	90	13	65	10032S
28	Z-12M28L	44	44	90	14	65	10032S
29	Z-12M29L	44	44	90	14	65	10032S
30	Z-12M30L	44	44	90	16.5	65	10032S
31	Z-12M31L	49	44	90	16.5	65	10032S
32	Z-12M32L	49	44	90	16.5	65	10034S
33	Z-12M33L	49	44	90	17	65	10034S
34	Z-12M34L	52	44	90	17	65	10034S
35	Z-12M35L	52	44	90	19	65	10034S
36	Z-12M36L	52	44	90	19	65	10034S
37	Z-12M37L	54	44	90	19	65	10034S
38	Z-12M38L	54	44	90	22	65	10034S
39	Z-12M39L	57	44	90	21.5	65	18708S
40	Z-12M40L	57	44	90	21.5	65	18708S
41	Z-12M41L	57	44	90	22	65	18708S
42	Z-12M42L	60	44	90	21.5	65	18708S
43	Z-12M43L	63	44	90	25	65	18708S
44	Z-12M44L	63	44	90	21.5	65	18708S
45	Z-12M45L	63	44	90	21.5	65	18708S
46	Z-12M46L	67	44	90	25.5	65	18708S
47	Z-12M47L	67	54	90	23.5	65	18708S
48	Z-12M48L	67	54	90	23.5	65	18708S
49	Z-12M49L	70	54	90	27	65	18708S
50	Z-12M50L	70	54	90	23.5	65	18708S
51	Z-12M51L	73	54	94	27	65	18710S
52	Z-12M52L	73	54	94	27	65	18710S
54	Z-12M54L	78	54	94	30	69	18710S
55	Z-12M55L	78	54	94	27	69	18710S
56	Z-12M56L	78	54	98	28	69	18710S
57	Z-12M57L	82	54	98	33	73	18710S
58	Z-12M58L	82	54	98	28	73	18710S
59	Z-12M59L	82	54	98	33	73	18710S
60	Z-12M60L	82	54	98	28	73	18710S
61	Z-12M61L	86	54	98	28	73	18710S

BUDD WHEEL SOCKETS



SIZE	PART#	D1	D2	L	T	RET RING
13/16	Z-1213B	1.653	1.732	1.950	0.433	10032S
13/16	Z-1213BL	1.653	1.732	3.510	0.433	18715S
13/16 X 1-1/12	Z-1224BS	2.126	1.732	3.510	0.571	10034S

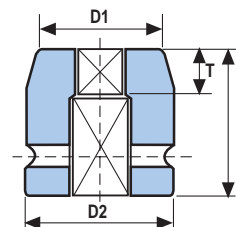

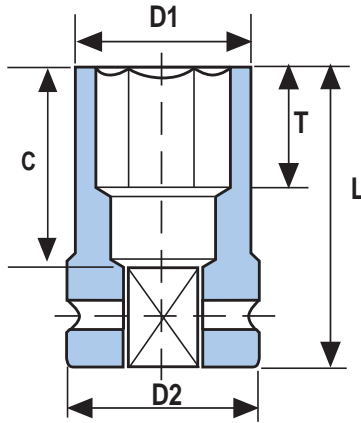

STANDARD FRACTIONAL THINWALL



SIZE	PART#	D1	D2	L	T	C	RET RING
11/16	Z-1211T	1.102	1.732	1.755	0.354	0.969	10032S
3/4	Z-1212T	1.181	1.732	1.755	0.375	0.969	10032S
13/16	Z-1213T	1.378	1.732	1.794	0.433	0.969	10032S
7/8	Z-1214T	1.378	1.732	1.794	0.512	0.969	10032S
15/16	Z-1215T	1.378	1.732	1.794	0.512	0.969	10032S
1	Z-1216T	1.496	1.732	1.794	0.512	0.969	10032S
1-1/16	Z-1217T	1.614	1.732	1.872	0.512	1.047	10032S
1-1/8	Z-1218T	1.614	1.732	2.028	0.650	1.047	10034S
1-3/16	Z-1219T	1.732	1.732	2.028	0.650	1.047	18708S
1-1/4	Z-1220T	1.732	1.732	2.028	0.669	1.047	18708S
1-5/16	Z-1221T	1.929	1.732	2.145	0.748	1.165	18708S
1-3/8	Z-1222T	2.047	1.732	2.145	0.748	1.165	18708S
1-7/16	Z-1223T	2.047	1.732	2.184	0.748	1.205	18708S
1-1/2	Z-1224T	2.126	1.732	2.301	0.866	1.283	18708S
1-9/16	Z-1225T	2.126	1.732	2.301	0.866	1.283	18708S
1-5/8	Z-1226T	2.126	1.732	2.301	0.866	1.283	18708S
1-11/16	Z-1227T	2.362	1.732	2.496	0.984	1.441	18708S
1-3/4	Z-1228T	2.362	1.732	2.496	0.995	1.480	18708S
1-13/16	Z-1229T	2.480	1.732	2.496	0.995	1.480	18708S

STANDARD METRIC THINWALL



SIZE	PART#	D1	D2	L	T	C	RET RING
17	Z-12M17T	28	44	45	9	20	10032S
18	Z-12M18T	30	44	45	9	20	10032S
19	Z-12M19T	30	44	45	9.5	21	10032S
20	Z-12M20T	30	44	46	10	21	10032S
21	Z-12M21T	35	44	46	10	21	10032S
22	Z-12M22T	35	44	46	10	21	10032S
23	Z-12M23T	35	44	46	12	21	10032S
24	Z-12M24T	38	44	46	12	21	10032S
25	Z-12M25T	38	44	46	13	21	10032S
26	Z-12M26T	41	44	46	13	21	10032S
27	Z-12M27T	41	44	48	13	23	10032S
28	Z-12M28T	41	44	48	14	23	10032S
29	Z-12M29T	41	44	52	14	27	10032S
30	Z-12M30T	41	44	52	16.5	27	10032S
31	Z-12M31T	44	44	52	16.5	27	10032S
32	Z-12M32T	48	44	52	16.5	27	10034S
33	Z-12M33T	48	44	55	17	30	10034S
34	Z-12M34T	49	44	55	17	30	10034S
35	Z-12M35T	50	44	55	19	30	10034S
36	Z-12M36T	52	44	56	19	31	10034S
37	Z-12M37T	52	44	56	19	31	10034S
38	Z-12M38T	52	44	59	22	34	10034S
39	Z-12M39T	54	44	59	21.5	34	18708S
40	Z-12M40T	54	44	59	21.5	34	18708S
41	Z-12M41T	54	44	59	22	34	18708S
42	Z-12M42T	57	44	59	21.5	34	18708S
43	Z-12M43T	60	44	64	25	39	18708S
44	Z-12M44T	60	44	64	21.5	39	18708S
45	Z-12M45T	60	44	64	21.5	39	18708S
46	Z-12M46T	63	44	64	25.5	39	18708S

DEEP FRACTIONAL THINWALL



SIZE	PART#	D1	D2	L	T	C	RET
RING							
11/16	Z-1211LT	1.102	1.732	3.510	0.709	2.543	10032S
3/4	Z-1212LT	1.181	1.732	3.510	0.748	2.543	10032S
13/16	Z-1213LT	1.378	1.732	3.510	0.866	2.543	10032S
7/8	Z-1214LT	1.378	1.732	3.510	1.024	2.543	10032S
15/16	Z-1215LT	1.378	1.732	3.510	1.024	2.543	10032S
1	Z-1216LT	1.496	1.732	3.510	1.024	2.543	10032S
1-1/16	Z-1217LT	1.614	1.732	3.510	1.024	2.543	10032S
1-1/8	Z-1218LT	1.614	1.732	3.510	1.299	2.543	10034S
1-3/16	Z-1219LT	1.732	1.732	3.510	1.299	2.543	18708S
1-1/4	Z-1220LT	1.732	1.732	3.510	1.339	2.543	18708S
1-5/16	Z-1221LT	1.929	1.732	3.510	1.496	2.543	18708S
1-3/8	Z-1222LT	2.047	1.732	3.510	1.496	2.543	18708S
1-7/16	Z-1223LT	2.047	1.732	3.510	1.496	2.543	18708S
1-1/2	Z-1224LT	2.126	1.732	3.510	1.732	2.543	18708S
1-9/16	Z-1225LT	2.126	1.732	3.510	1.732	2.543	18708S
1-5/8	Z-1226LT	2.126	1.732	3.510	1.732	2.543	18708S
1-11/16	Z-1227LT	2.362	1.732	3.510	1.969	2.543	18708S
1-3/4	Z-1228LT	2.362	1.732	3.510	2.008	2.543	18708S
1-13/16	Z-1229LT	2.480	1.732	3.510	2.008	2.543	18708S

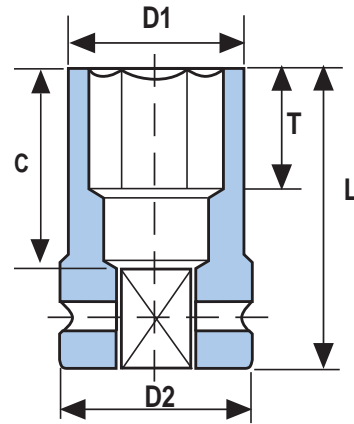

DEEP METRIC THINWALL



SIZE	PART#	D1	D2	L	T	C	RET
RING							
17	Z-12M17LT	28	44	90	18	65	10032S
18	Z-12M18LT	30	44	90	18	65	10032S
19	Z-12M19LT	30	44	90	19	65	10032S
20	Z-12M20LT	30	44	90	20	65	10032S
21	Z-12M21LT	35	44	90	20	65	10032S
22	Z-12M22LT	35	44	90	20	65	10032S
23	Z-12M23LT	35	44	90	24	65	10032S
24	Z-12M24LT	38	44	90	24	65	10032S
25	Z-12M25LT	38	44	90	26	65	10032S
26	Z-12M26LT	41	44	90	26	65	10032S
27	Z-12M27LT	41	44	90	26	65	10032S
28	Z-12M28LT	41	44	90	28	65	10032S
29	Z-12M29LT	41	44	90	28	65	10032S
30	Z-12M30LT	41	44	90	33	65	10032S
31	Z-12M31LT	44	44	90	33	65	10032S
32	Z-12M32LT	48	44	90	33	65	10034S
33	Z-12M33LT	48	44	90	34	65	10034S
34	Z-12M34LT	49	44	90	34	65	10034S
35	Z-12M35LT	50	44	90	38	65	10034S
36	Z-12M36LT	52	44	90	38	65	10034S
37	Z-12M37LT	52	44	90	38	65	10034S
38	Z-12M38LT	52	44	90	44	65	10034S
39	Z-12M39LT	54	44	90	43	65	18708S
40	Z-12M40LT	54	44	90	43	65	18708S
41	Z-12M41LT	54	44	90	44	65	18708S
42	Z-12M42LT	57	44	90	43	65	18708S
43	Z-12M43LT	60	44	90	50	65	18708S
44	Z-12M44LT	60	44	90	43	65	18708S
45	Z-12M45LT	60	44	90	43	65	18708S
46	Z-12M46LT	63	44	90	51	65	18708S



3/4" SQUARE DRIVE

HEX DRIVER SOCKETS

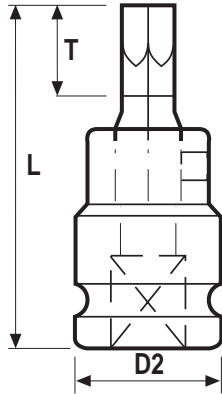

FRACTIONAL SIZES

SIZE	PART#	D2	L	T	RET RING
3/8	Z-1206H	1.496	2.637	1.130	10032S
7/16	Z-1207H	1.496	2.637	1.130	10032S
1/2	Z-1208H	1.496	2.637	1.130	10032S
9/16	Z-1209H	1.496	2.637	1.130	10032S
5/8	Z-1210H	1.496	2.637	1.130	10032S
3/4	Z-1212H	1.732	2.637	1.130	10032S
13/16	Z-1213H	1.732	2.795	1.295	10032S
7/8	Z-1214H	1.732	2.795	1.295	10032S
1	Z-1216H	1.732	2.795	1.295	10032S

Note: 1 Piece Construction

METRIC SIZES

SIZE	PART#	D2	L	T	RET RING
10	Z-12M10H	38	67	29	10032S
12	Z-12M12H	38	67	29	10032S
14	Z-12M14H	38	67	29	10032S
17	Z-12M17H	38	67	29	10032S
19	Z-12M19H	44	67	29	10032S
22	Z-12M22H	44	71	33	10032S
24	Z-12M24H	44	71	33	10032S

Note: 1 Piece Construction

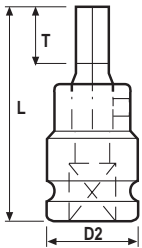

2 PART INHEX

NOMINAL OPENING		CATALOG No.	D2 mm	L mm	T mm	Weight gr	Ret Ring	Replacement Hex Bits
mm	A/F Inch							
	3/8"	Z-1206V	38	69	16	310	10032S	H06
	7/16"	Z-1207V	38	69	18	310	10032S	H07
	1/2"	Z-1208V	38	69	19	310	10032S	H08
	9/16"	Z-1209V	38	69	21	310	10032S	H09
	5/8"	Z-1210V	38	69	24	310	10032S	H10
	3/4"	Z-1212V	44	69	26	630	10032S	H12
	13/16"	Z-1213V	44	84	26	630	10032S	H13
	7/8"	Z-1214V	44	84	26	630	10032S	H14
	1"	Z-1216V	44	104	30	630	10032S	H16
10		Z-12M10V	38	69	16	310	10032S	HM10
12		Z-12M12V	38	69	18	310	10032S	HM12
14		Z-12M14V	38	69	21	310	10032S	HM14
17		Z-12M17V	38	69	26	310	10032S	HM17
19		Z-12M19V	44	84	26	630	10032S	HM19
22		Z-12M22V	44	84	26	630	10032S	HM22
24		Z-12M24V	44	84	26	630	10032S	HM24

Note: 2 Piece Construction



DOUBLE SQUARE IMPACT EIGHT POINT SOCKETS



STANDARD FRACTIONAL SIZES

SIZE	PART#	D1	D2	L	T	C	RET RING
1-1/4	DS-1220	2.362	1.732	2.067	0.669	1.087	18708S
1-5/16	DS-1221	2.480	1.732	2.067	0.748	1.087	18708S
1-3/8	DS-1222	2.638	1.732	2.067	0.748	1.087	18708S
1-7/16	DS-1223	2.638	1.732	2.223	0.748	1.244	18708S
1-1/2	DS-1224	2.638	1.732	2.223	0.866	1.244	18708S
1-9/16	DS-1225	3.071	2.126	2.223	0.866	1.244	18708S
1-5/8	DS-1226	3.071	2.126	2.223	0.866	1.244	18708S
1-11/16	DS-1227	3.228	2.126	2.418	0.984	1.441	18708S
1-3/4	DS-1228	3.228	2.126	2.457	1.005	1.480	18708S
1-13/16	DS-1229	3.228	2.126	2.457	1.005	1.480	18708S
1-7/8	DS-1230	3.228	2.126	2.535	1.063	1.559	18708S

DEEP FRACTIONAL SIZES

SIZE	PART#	D1	D2	L	T	C	RET RING
1-1/4	DS-1220L	2.362	1.732	3.159	0.669	2.189	18708S
1-5/16	DS-1221L	2.480	1.732	3.159	0.748	2.189	18708S
1-3/8	DS-1222L	2.638	1.732	3.159	0.748	2.189	18708S
1-7/16	DS-1223L	2.638	1.732	3.159	0.748	2.189	18708S
1-1/2	DS-1224L	2.638	1.732	3.159	0.866	2.189	18708S
1-9/16	DS-1225L	3.071	2.126	3.159	0.866	2.189	18708S
1-5/8	DS-1226L	3.071	2.126	3.159	0.866	2.189	18708S
1-11/16	DS-1227L	3.228	2.126	3.159	0.984	2.189	18708S
1-3/4	DS-1228L	3.228	2.126	3.159	1.005	2.189	18708S
1-13/16	DS-1229L	3.228	2.126	3.159	1.005	2.189	18708S
1-7/8	DS-1230L	3.228	2.126	3.159	1.063	2.189	18708S

12 POINT IMPACT SOCKETS REGULAR LENGTH



NOMINAL OPENING			D1	D2	L	tmin	Weight	Ret
mm	A/F Inch	CATALOG No.	mm	mm	mm	mm	gr	Ring
19	3/4"	DH-1212M19	32	44	45	9.5	290	10032S
	15/16"	DH-1215	40	44	46	13.0	340	10032S
	1"	DH-1216	41	44	46	13.0	340	10032S
27	1-1/16"	DH-1217M27	41	44	48	13.0	340	10032S
	1-1/8"	DH-1218	44	44	52	16.5	380	10034S
30	1-3/16"	DH-1219M30	44	44	52	16.5	380	18708S
	1-1/4"	DH-1220	49	44	52	17.0	420	18708S
	1-5/16"	DH-1221	49	44	55	19.0	430	18708S
33		DH-12M33	49	44	55	17.0	430	18708S
34		DH-12M34	52	44	55	19.0	460	18708S
35	1-3/8"	DH-1222M35	52	44	55	19.0	460	18708S
36		DH-12M36	52	44	55	19.0	460	18708S
	1-7/16"	DH-1223	52	44	56	19.0	460	18708S
37		DH-12M37	54	44	56	19.0	490	18708S
38	1-1/2"	DH-1224M38	54	44	59	22.0	490	18708S
39		DH-12M39	57	44	59	22.0	520	18708S
	1-9/16"	DH-1225	57	44	59	22.0	520	18708S
40		DH-12M40	57	44	59	22.0	520	18708S
41	1-5/8"	DH-1226M41	57	44	59	22.0	520	18708S
42		DH-12M42	60	44	59	22.0	520	18708S
43	1-11/16"	DH-1227M43	63	44	64	25.0	600	18708S
44		DH-12M44	63	44	64	25.0	600	18708S
	1-3/4"	DH-1228	63	44	64	25.0	600	18708S
45		DH-12M45	63	44	64	25.0	600	18708S
46	1-13/16"	DH-1229M46	67	44	64	25.0	850	18708S
47		DH-12M47	67	54	64	25.0	850	18708S
	1-7/8"	DH-1230	67	54	67	27.0	910	18708S
48		DH-12M48	67	54	67	27.0	910	18708S
49	1-15/16"	DH-1231M49	70	54	67	27.0	950	18708S
50		DH-12M50	70	54	67	27.0	950	18708S
51	2"	DH-1232M51	73	54	67	27.0	1040	18708S
52		DH-12M52	73	54	70	27.0	1040	18708S
	2-1/16"	DH-1233	73	54	71	30.0	1040	18708S
54	2-1/8"	DH-1234M54	73	54	71	30.0	1040	18708S
55		DH-12M55	78	54	71	30.0	1200	18708S
	2-3/16"	DH-1235	78	54	74	32.0	1200	18708S
56		DH-12M56	78	54	74	32.0	1200	18708S
57	2-1/4"	DH-1236M57	82	54	75	33.0	1320	18708S
58		DH-12M58	82	54	75	33.0	1320	18708S
59	2-5/16"	DH-1237M59	82	54	75	33.0	1320	18708S
60		DH-12M60	82	54	75	33.0	1320	18708S
	2-3/8"	DH-1238	82	54	75	35.0	1320	18708S
61		DH-12M61	86	54	75	35.0	1430	18708S

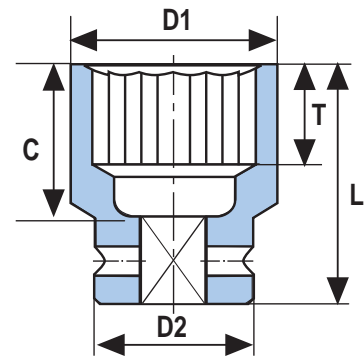

3/4" SQUARE DRIVE

ACCESSORIES

ADAPTERS

PART#	FEMALE	MALE	L	RET RING
A1208	3/4	1/2	2.165	10032S
A1210	3/4	5/8	2.244	10032S
A1216	3/4	1	2.322	10032S

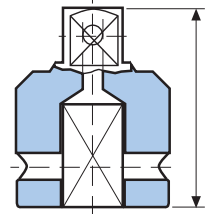

DOUBLE ENDED FEMALE ADAPTERS

PART#	D1	D2	L	Ret Rings	
				A	B
AN1208	3/4	1/2	1.929	10032S	10005S
AN1210	3/4	5/8	1.968	10032S	10005S
AN1212	3/4	3/4	1.929	10032S	10032S
AN1612	3/4	1	2.480	10032S	10008S

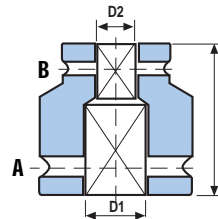

DOUBLE ENDED MALE ADAPTERS

PART#	D1	L
Z1202	1	2
Z1203	1	3
Z1204	1	4
Z1205	1	5
Z1207	1	7
Z1210	1	10
Z1213	1	13
Z1215	1	15
Z1216	1	16

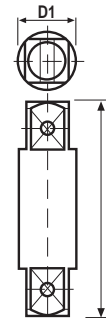

UNIVERSAL JOINT

SIZE	PART#	RR*
3/4	U1212	10032S

*RR - Retainer Ring

EXTENSIONS

PART#	L	RR*
E1203	3	10032S
E1204	4	10032S
E1205	5	10032S
E1207	7	10032S
E1213	13	10032S

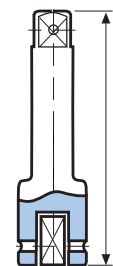

RETAINING PINS AND RINGS

SQUARE DRIVE	THROUGH HEX SIZE	PIN #	RING#	d	L	D
3/4	1-3/16 - 46mm	P1244	R1244	.156	1.365	1.404
5/8	Above 1-3/16	P1254	R1254	.156	1.750	1.794

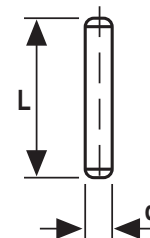
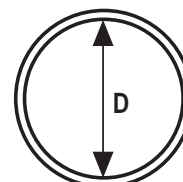

RAILROAD SOCKETS



3/4" SQUARE DRIVE DOUBLE SQUARE IMPACT EIGHT POINT SOCKETS



STANDARD FRACTIONAL SIZES

SIZE	PART#	D1	D2	L	T	C	RET RING
1-1/4	DS-1220	2.362	1.732	2.067	0.669	1.087	18708S
1-5/16	DS-1221	2.480	1.732	2.067	0.748	1.087	18708S
1-3/8	DS-1222	2.638	1.732	2.067	0.748	1.087	18708S
1-7/16	DS-1223	2.638	1.732	2.223	0.748	1.244	18708S
1-1/2	DS-1224	2.638	1.732	2.223	0.866	1.244	18708S
1-9/16	DS-1225	3.071	2.126	2.223	0.866	1.244	18708S
1-5/8	DS-1226	3.071	2.126	2.223	0.866	1.244	18708S
1-11/16	DS-1227	3.228	2.126	2.418	0.984	1.441	18708S
1-3/4	DS-1228	3.228	2.126	2.457	1.005	1.480	18708S
1-13/16	DS-1229	3.228	2.126	2.457	1.005	1.480	18708S
1-7/8	DS-1230	3.228	2.126	2.535	1.063	1.559	18708S

DEEP FRACTIONAL SIZES

SIZE	PART#	D1	D2	L	T	C	RET RING
1-1/4	DS-1220L	2.362	1.732	3.159	0.669	2.189	18708S
1-5/16	DS-1221L	2.480	1.732	3.159	0.748	2.189	18708S
1-3/8	DS-1222L	2.638	1.732	3.159	0.748	2.189	18708S
1-7/16	DS-1223L	2.638	1.732	3.159	0.748	2.189	18708S
1-1/2	DS-1224L	2.638	1.732	3.159	0.866	2.189	18708S
1-9/16	DS-1225L	3.071	2.126	3.159	0.866	2.189	18708S
1-5/8	DS-1226L	3.071	2.126	3.159	0.866	2.189	18708S
1-11/16	DS-1227L	3.228	2.126	3.159	0.984	2.189	18708S
1-3/4	DS-1228L	3.228	2.126	3.159	1.005	2.189	18708S
1-13/16	DS-1229L	3.228	2.126	3.159	1.005	2.189	18708S
1-7/8	DS-1230L	3.228	2.126	3.159	1.063	2.189	18708S



1" SQUARE DRIVE DOUBLE SQUARE IMPACT EIGHT POINT SOCKETS



STANDARD FRACTIONAL SIZES

SIZE	PART#	D1	D2	L	T	C	RET RING
1-5/16	DS-1621	2.480	2.126	2.262	0.748	1.283	10008S
1-3/8	DS-1622	2.638	2.362	2.262	0.748	1.283	10008S
1-7/16	DS-1623	2.638	2.362	2.262	0.748	1.283	10015S
1-1/2	DS-1624	2.756	2.362	2.418	0.866	1.441	10015S
1-9/16	DS-1625	3.071	2.362	2.418	0.866	1.441	10015S
1-5/8	DS-1626	3.071	2.362	2.418	0.866	1.441	10015S
1-11/16	DS-1627	3.228	2.362	2.613	0.984	1.638	10016S
1-3/4	DS-1628	3.228	2.362	2.613	1.005	1.638	10016S
1-13/16	DS-1629	3.386	2.362	2.613	1.005	1.638	10016S
1-7/8	DS-1630	3.386	2.362	2.730	1.063	1.756	10016S
2	DS-1632	3.622	2.362	2.730	1.063	1.756	10016S
2-1/8	DS-1634	3.937	2.362	2.925	1.181	1.953	10017S
2-3/16	DS-1635	3.937	2.362	3.042	1.260	2.071	10017S
2-1/4	DS-1636	3.937	2.362	3.042	1.260	2.071	10017S
2-3/8	DS-1638	4.134	2.362	3.198	1.378	2.228	10017S
2-1/2	DS-1640	4.291	2.362	3.432	1.378	2.465	10017S

Note: Metric Sizes 35, 38, 41, 46, 51, 54, 57 are also available by special order. (POA)

DEEP FRACTIONAL SIZES

SIZE	PART#	D1	D2	L	T	C	RET RING
1-5/16	DS-1621L	2.480	2.126	3.159	0.748	2.189	10008S
1-3/8	DS-1622L	2.638	2.362	3.159	0.748	2.189	10008S
1-7/16	DS-1623L	2.638	2.362	3.159	0.748	2.189	10015S
1-1/2	DS-1624L	2.756	2.362	3.393	0.866	2.322	10015S
1-9/16	DS-1625L	3.071	2.362	3.432	0.866	2.322	10015S
1-5/8	DS-1626L	3.071	2.362	3.432	0.866	2.322	10015S
1-11/16	DS-1627L	3.228	2.362	3.432	0.984	2.322	10016S
1-3/4	DS-1628L	3.228	2.362	3.432	1.005	2.322	10016S
1-13/16	DS-1629L	3.386	2.362	3.432	1.005	2.322	10016S
1-7/8	DS-1630L	3.386	2.362	3.432	1.063	2.322	10016S
2	DS-1632L	3.622	2.362	3.432	1.063	2.322	10016S
2-1/8	DS-1634L	3.937	2.362	3.783	1.181	2.819	10017S
2-3/16	DS-1635L	3.937	2.362	3.783	1.260	2.819	10017S
2-1/4	DS-1636L	3.937	2.362	3.900	1.260	2.937	10017S
2-3/8	DS-1638L	4.134	2.362	3.900	1.378	2.937	10017S
2-1/2	DS-1640L	4.291	2.362	3.900	1.378	2.937	10017S

Note: Metric Sizes 35, 38, 41, 46, 51, 54, 57 are also available by special order. (POA)

SPECIAL RAILROAD SOCKETS

PART NUMBER	DESCRIPTION	RET RING
N4046A	15/16" X 1/2" Six Point Extended Socket	
N4046A-1	1" X 1/2" Six Point Extended Socket	
Z-161418RTL	7/8" X 1-1/8" Rectangle X 1" SQ. DR.	10008S
Z-16T70	70MM X 1" SQ. DR. Torx Bit Socket	10008S
N7167A	Domed Head Socket w/Pins	10015S

Railroad Sockets are also available in square 4 point and rectangular 4 point tapered to fit Lag Screws by special order. (POA)

N4046A-1

N4046A

Z-161418 RTL

N7167A

Z-16T70

1" SQUARE DRIVE

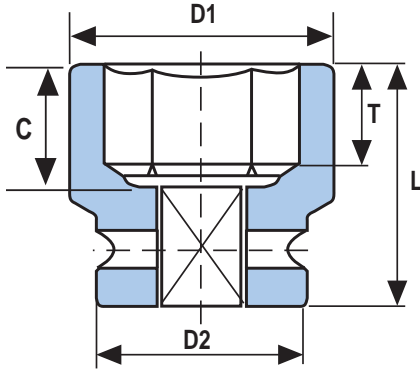

ATP maintains "in stock" one of the broadest ranges of 1" drive sockets available to industry. OZAT 1" drive sizes are equally well suited for construction, maintenance, and heavy assembly applications, as well as for precision bolting with hydraulic bolting equipment.

SIX POINT IMPACT SOCKETS

STANDARD FRACTIONAL SIZES



SIZE	PART#	D1	D2	L	T	C	RET RING
3/4	Z-1612	1.417	2.126	2.145	0.374	1.040	10008S
13/16	Z-1613	1.496	2.126	2.145	0.433	1.040	10008S
7/8	Z-1614	1.575	2.126	2.145	0.551	1.040	10008S
15/16	Z-1615	1.614	2.126	2.145	0.551	1.040	10008S
1	Z-1616	1.693	2.126	2.145	0.551	1.119	10008S
1-1/16	Z-1617	1.811	2.126	2.145	0.551	1.119	10008S
1-1/8	Z-1618	1.890	2.126	2.223	0.650	1.119	10008S
1-3/16	Z-1619	1.969	2.126	2.223	0.650	1.119	10008S
1-1/4	Z-1620	2.008	2.126	2.223	0.669	1.119	10008S
1-5/16	Z-1621	2.126	2.126	2.340	0.748	1.198	10008S
1-3/8	Z-1622	2.126	2.126	2.340	0.748	1.198	10010S
1-7/16	Z-1623	2.126	2.126	2.340	0.748	1.198	10010S
1-1/2	Z-1624	2.362	2.126	2.496	0.866	1.316	10010S
1-9/16	Z-1625	2.362	2.126	2.496	0.866	1.316	10015S
1-5/8	Z-1626	2.480	2.126	2.496	0.866	1.316	10015S
1-11/16	Z-1627	2.638	2.126	2.691	0.984	1.513	10015S
1-3/4	Z-1628	2.756	2.126	2.691	1.004	1.592	10016S
1-13/16	Z-1629	2.756	2.126	2.691	1.004	1.592	10016S
1-7/8	Z-1630	2.756	2.126	2.808	1.062	1.631	10016S
1-15/16	Z-1631	2.874	2.126	2.808	1.062	1.631	10016S
2	Z-1632	2.874	2.126	2.808	1.062	1.631	10016S
2-1/16	Z-1633	3.071	2.126	2.964	1.181	1.828	10016S
2-1/8	Z-1634	3.228	2.126	2.964	1.181	1.828	10016S
2-3/16	Z-1635	3.228	2.126	3.120	1.259	1.946	10016S
2-1/4	Z-1636	3.228	2.126	3.120	1.299	1.946	10016S
2-5/16	Z-1637	3.386	2.126	3.198	1.299	2.025	10016S
2-3/8	Z-1638	3.386	2.126	3.315	1.378	2.418	10016S
2-7/16	Z-1639	3.622	2.126	3.315	1.378	2.418	10016S
2-1/2	Z-1640	3.622	2.126	3.315	1.378	2.418	10016S
2-9/16	Z-1641	3.622	2.126	3.315	1.378	2.458	10017S
2-5/8	Z-1642	3.622	2.126	3.432	1.496	2.536	10017S
2-11/16	Z-1643	3.780	2.126	3.432	1.496	2.576	10017S
2-3/4	Z-1644	3.780	3.386	3.432	1.496	2.615	10017S
2-13/16	Z-1645	3.937	3.386	3.588	1.575	2.615	10017S
2-7/8	Z-1646	3.937	3.386	3.588	1.614	2.615	10017S
2-15/16	Z-1647	3.937	3.386	3.588	1.614	2.615	10017S
3	Z-1648	4.134	3.386	3.783	1.732	2.655	10017S
3-1/16	Z-1649	4.134	3.386	3.783	1.732	2.655	10017S
3-1/8	Z-1650	4.134	3.386	3.783	1.732	2.655	10017S
3-3/16	Z-1651	4.291	3.386	3.900	1.850	2.812	10017S
3-1/4	Z-1652	4.291	3.386	3.900	1.850	2.812	10017S
3-5/16	Z-1653	4.291	3.386	3.900	1.850	2.812	10017S
3-3/8	Z-1654	4.291	3.386	4.056	1.929	2.930	10017S
3-7/16	Z-1655	4.764	3.386	4.056	1.929	2.930	10017S
3-1/2	Z-1656	4.764	3.386	4.056	1.929	2.930	10017S
3-9/16	Z-1657	5.000	3.386	4.056	1.890	2.930	10019S
3-5/8	Z-1658	5.118	3.386	4.056	1.929	2.930	10019S
3-11/16	Z-1659	5.118	3.386	4.056	1.929	2.930	10019S
3-3/4	Z-1660	5.315	3.386	4.134	1.929	3.245	10019S
3-13/16	Z-1661	5.315	3.386	4.368	2.125	3.245	10019S
3-7/8	Z-1662	5.315	3.386	4.368	2.125	3.245	10019S
3-15/16	Z-1663	5.315	3.386	4.368	2.125	3.245	10019S
4	Z-1664	5.512	5	4.368	2.125	3.245	10019S
4-1/16	Z-1665	4.512	5	4.368	2.125	3.245	10019S
4-1/8	Z-1666	5.709	5	4.368	2.125	3.245	10019S
4-3/16	Z-1667	5.709	5	4.758	2.441	3.245	10019S
4-1/4	Z-1668	5.709	5	4.758	2.441	3.599	10019S
4-5/16	Z-1669	5.906	5	4.758	2.441	3.599	10019S
4-3/8	Z-1670	5.906	5	4.758	2.441	3.599	10019S
4-7/16	Z-1671	6.102	5	4.758	2.441	3.599	10019S
4-1/2	Z-1672	6.102	5	4.758	2.441	3.599	10019S

1" SQUARE DRIVE

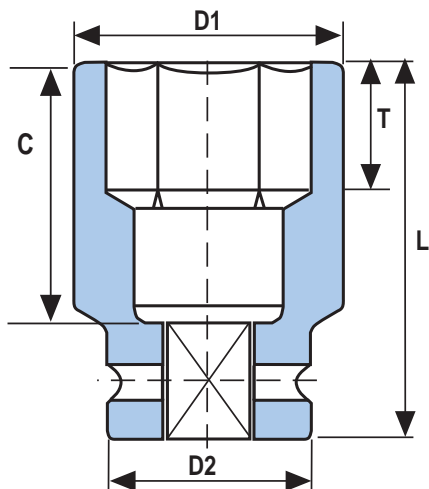

SIX POINT IMPACT SOCKETS

DEEP FRACTIONAL SIZES



SIZE	PART#	D1	D2	L	T	C	RET RING
3/4	Z-1612L	1.417	2.126	3.900	0.374	2.812	10008S
13/16	Z-1613L	1.496	2.126	3.900	0.433	2.812	10008S
7/8	Z-1614L	1.575	2.126	3.900	0.551	2.812	10008S
15/16	Z-1615L	1.614	2.126	3.900	0.551	2.812	10008S
1	Z-1616L	1.693	2.126	3.900	0.551	2.812	10008S
1-1/16	Z-1617L	1.811	2.126	3.900	0.551	2.812	10008S
1-1/8	Z-1618L	1.890	2.126	3.900	0.650	2.812	10008S
1-3/16	Z-1619L	1.969	2.126	3.900	0.650	2.812	10008S
1-1/4	Z-1620L	2.008	2.126	3.900	0.669	2.812	10008S
1-5/16	Z-1621L	2.126	2.126	3.900	0.748	2.812	10008S
1-3/8	Z-1622L	2.126	2.126	3.900	0.748	2.812	10010S
1-7/16	Z-1623L	2.126	2.126	3.900	0.748	2.812	10010S
1-1/2	Z-1624L	2.362	2.126	3.900	0.866	2.812	10010S
1-9/16	Z-1625L	2.362	2.126	3.900	0.866	2.812	10015S
1-5/8	Z-1626L	2.480	2.126	3.900	0.866	2.812	10015S
1-11/16	Z-1627L	2.638	2.126	3.900	0.984	2.812	10015S
1-3/4	Z-1628L	2.756	2.126	3.900	1.004	2.812	10016S
1-13/16	Z-1629L	2.756	2.126	3.900	1.004	2.812	10016S
1-7/8	Z-1630L	2.756	2.126	3.900	1.062	2.812	10016S
1-15/16	Z-1631L	2.874	2.126	3.900	1.062	2.812	10016S
2	Z-1632L	2.874	2.126	3.900	1.062	2.812	10016S
2-1/16	Z-1633L	3.071	2.126	3.900	1.181	2.969	10016S
2-1/8	Z-1634L	3.228	2.126	4.056	1.181	2.969	10016S
2-3/16	Z-1635L	3.228	2.126	4.095	1.259	3.088	10016S
2-1/4	Z-1636L	3.228	2.126	4.095	1.299	3.088	10016S
2-5/16	Z-1637L	3.386	2.126	4.368	1.299	3.166	10016S
2-3/8	Z-1638L	3.386	2.126	4.368	1.378	3.560	10016S
2-7/16	Z-1639L	3.622	2.126	4.602	1.378	3.560	10016S
2-1/2	Z-1640L	3.622	2.126	4.602	1.378	3.560	10016S
2-9/16	Z-1641L	3.622	2.126	4.602	1.378	3.599	10017S
2-5/8	Z-1642L	3.622	2.126	4.602	1.496	3.678	10017S
2-11/16	Z-1643L	3.780	2.126	4.836	1.496	3.718	10017S
2-3/4	Z-1644L	3.780	3.386	4.836	1.496	3.757	10017S
2-13/16	Z-1645L	3.937	3.386	4.836	1.575	3.757	10017S
2-7/8	Z-1646L	3.937	3.386	4.836	1.614	3.757	10017S
2-15/16	Z-1647L	3.937	3.386	4.836	1.614	3.757	10017S
3	Z-1648L	4.134	3.386	5.07	1.732	3.796	10017S
3-1/16	Z-1649L	4.134	3.386	5.07	1.732	3.796	10017S
3-1/8	Z-1650L	4.134	3.386	5.148	1.732	3.796	10017S
3-3/16	Z-1651L	4.291	3.386	5.148	1.850	3.954	10017S
3-1/4	Z-1652L	4.291	3.386	5.148	1.850	3.954	10017S
3-5/16	Z-1653L	4.291	3.386	5.148	1.850	3.954	10017S
3-3/8	Z-1654L	4.291	3.386	5.460	1.929	4.072	10017S
3-7/16	Z-1655L	4.764	3.386	5.460	1.929	4.072	10017S
3-1/2	Z-1656L	4.764	3.386	5.460	1.929	4.072	10017S
3-9/16	Z-1657L	5.000	3.386	5.460	1.890	4.072	10019S
3-5/8	Z-1658L	5.118	3.386	5.460	1.929	4.072	10019S
3-11/16	Z-1659L	5.118	3.386	5.460	1.929	4.072	10019S
3-3/4	Z-1660L	5.315	3.386	5.460	1.929	4.387	10019S
3-13/16	Z-1661L	5.315	3.386	5.577	2.125	4.387	10019S
3-7/8	Z-1662L	5.315	3.386	5.577	2.125	4.387	10019S
3-15/16	Z-1663L	5.315	3.386	5.577	2.125	4.387	10019S
4	Z-1664L	5.512	5.000	5.577	2.125	4.387	10019S
4-1/16	Z-1665L	4.512	5.000	5.577	2.125	4.387	10019S
4-1/8	Z-1666L	5.709	5.000	5.577	2.125	4.387	10019S
4-3/16	Z-1667L	5.709	5.000	5.811	2.441	4.387	10019S
4-1/4	Z-1668L	5.709	5.000	5.811	2.441	4.741	10019S
4-5/16	Z-1669L	5.906	5.000	5.811	2.441	4.741	10019S
4-3/8	Z-1670L	5.906	5.000	5.811	2.441	4.741	10019S
4-7/16	Z-1671L	6.102	5.000	5.811	2.441	4.741	10019S
4-1/2	Z-1672L	6.102	5.000	5.811	2.441	4.741	10019S

1" SQUARE DRIVE

SIX POINT IMPACT SOCKETS

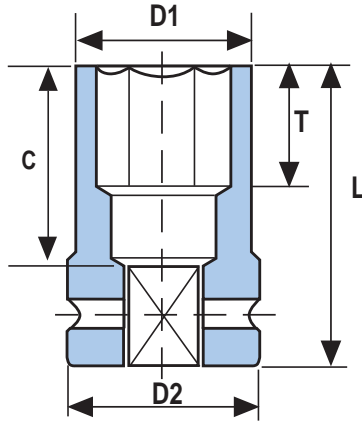

DEEP FRACTIONAL THINWALL



SIZE	PART#	D1	D2	L	T	C	RET RING
7/8	Z-1614LT	1.496	2.126	3.937	.500	2.812	10008S
15/16	Z-1615LT	1.496	2.126	3.937	.500	2.812	10008S
1	Z-1616LT	1.614	2.126	3.937	.500	2.812	10008S
1-1/16	Z-1617LT	1.732	2.126	3.937	.500	2.812	10008S
1-1/8	Z-1618LT	1.732	2.126	3.937	.500	2.812	10008S
1-3/16	Z-1619LT	1.929	2.126	3.937	1.299	2.812	10008S
1-1/4	Z-1620LT	1.929	2.126	3.937	1.339	2.812	10008S
1-5/16	Z-1621LT	2.047	2.126	3.937	1.496	2.812	10008S
1-3/8	Z-1622LT	2.047	2.126	3.937	1.496	2.812	10010S
1-7/16	Z-1623LT	2.126	2.126	3.937	1.496	2.812	10010S
1-1/2	Z-1624LT	2.224	2.126	3.937	1.732	2.812	10010S
1-9/16	Z-1625LT	2.244	2.126	3.937	1.732	2.812	10015S
1-5/8	Z-1626LT	2.362	2.126	3.937	1.732	2.812	10015S
1-11/16	Z-1627LT	2.480	2.126	3.937	1.968	2.812	10015S
1-3/4	Z-1628LT	2.638	2.126	3.937	2.008	2.812	10016S
1-13/16	Z-1629LT	2.638	2.126	3.937	2.008	2.812	10016S

DEEP METRIC THINWALL



SIZE	PART#	D1	D2	L	T	C	RET RING
22	Z-16M22LT	38	54	100	20	71	10008S
23	Z-16M23LT	38	54	100	24	71	10008S
24	Z-16M24LT	38	54	100	24	71	10008S
25	Z-16M25LT	41	54	100	26	71	10008S
26	Z-16M26LT	44	54	100	26	71	10008S
27	Z-16M27LT	44	54	100	26	71	10008S
28	Z-16M28LT	44	54	100	28	71	10008S
29	Z-16M29LT	44	54	100	28	71	10008S
30	Z-16M30LT	49	54	100	33	71	10008S
31	Z-16M31LT	49	54	100	33	71	10008S
32	Z-16M32LT	49	54	100	33	71	10008S
33	Z-16M33LT	52	54	100	34	71	10008S
34	Z-16M34LT	52	54	100	34	71	10008S
35	Z-16M35LT	52	54	100	38	71	10010S
36	Z-16M36LT	54	54	100	38	71	10010S
37	Z-16M37LT	54	54	100	38	71	10010S
38	Z-16M38LT	54	54	100	43	71	10010S
39	Z-16M39LT	54	54	100	43	71	10015S
40	Z-16M40LT	54	54	100	43	71	10015S
41	Z-16M41LT	54	54	100	44	71	10015S
42	Z-16M42LT	54	54	100	44	71	10015S
43	Z-16M43LT	54	54	100	50	71	10015S
44	Z-16M44LT	54	54	100	50	71	10016S
45	Z-16M45LT	54	54	100	51	71	10016S
46	Z-16M46LT	54	54	100	51	71	10016S

See page 80 for information on "special" sockets. OZAT routinely manufactures extra deep, extra heavy, spark resistant, special shape, or special drive type sockets.

1" SQUARE DRIVE

STANDARD METRIC SIZES



SIZE	PART#	D1	D2	L	T	C	RET RING
19	Z-16M19	36	54	55	9.5	26	10008S
20	Z-16M20	37	54	55	10	26	10008S
21	Z-16M21	38	54	55	10	26	10008S
22	Z-16M22	40	54	55	10	26	10008S
23	Z-16M23	41	54	55	12	26	10008S
24	Z-16M24	42	54	55	12	26	10008S
25	Z-16M25	43	54	55	13	26	10008S
26	Z-16M26	45	54	55	13	26	10008S
27	Z-16M27	46	54	55	13	26	10008S
28	Z-16M28	47	54	55	14	26	10008S
29	Z-16M29	48	54	57	14	28	10008S
30	Z-16M30	50	54	57	16.5	28	10008S
31	Z-16M31	51	54	57	16.5	28	10008S
32	Z-16M32	51	54	57	16.5	28	10008S
33	Z-16M33	54	54	57	17	28	10008S
34	Z-16M34	54	54	60	19	31	10008S
35	Z-16M35	54	54	60	19	31	10010S
36	Z-16M36	54	54	60	19	31	10010S
37	Z-16M37	57	54	60	19	31	10010S
38	Z-16M38	60	54	64	22	35	10010S
39	Z-16M39	60	54	64	21.5	35	10015S
40	Z-16M40	63	54	64	21.5	35	10015S
41	Z-16M41	63	54	64	22	35	10015S
42	Z-16M42	63	54	64	21.5	35	10015S
43	Z-16M43	67	54	69	25	40	10015S
44	Z-16M44	67	54	69	21.5	40	10016S
45	Z-16M45	70	54	69	21.5	40	10016S
46	Z-16M46	70	54	69	25.5	40	10016S
47	Z-16M47	70	54	69	23.5	40	10016S
48	Z-16M48	73	54	72	23.5	43	10016S
49	Z-16M49	73	54	72	27	43	10016S
50	Z-16M50	73	54	72	23.5	43	10016S
51	Z-16M51	73	54	72	27	43	10016S
52	Z-16M52	78	54	72	27	43	10016S
54	Z-16M54	82	54	76	30	47	10016S
55	Z-16M55	82	54	76	27	47	10016S
56	Z-16M56	82	54	75	28	46	10016S
57	Z-16M57	82	54	80	33	51	10016S
58	Z-16M58	86	54	75	28	46	10016S
59	Z-16M59	86	54	82	33	53	10016S
60	Z-16M60	86	54	75	28	46	10016S
61	Z-16M61	88	54	85	28	56	10017S
62	Z-16M62	92	54	85	35	56	10017S
65	Z-16M65	92	54	85	35	56	10017S
67	Z-16M67	92	54	88	38	62	10017S
70	Z-16M70	96	54	88	38	79	10017S
73	Z-16M73	100	86	92	41	83	10017S
75	Z-16M75	100	86	92	41	83	10017S
76	Z-16M76	105	86	97	44	68	10017S
80	Z-16M80	105	86	97	37	59	10017S
85	Z-16M85	115	86	100	40	63	10017S
86	Z-16M86	115	86	104	49	75	10017S
90	Z-16M90	127	86	104	43	68	10017S
95	Z-16M95	135	86	106	49	77	10019S
100	Z-16M100	135	86	112	54	83	10019S
105	Z-16M105	145	127	112	54	83	10019S
110	Z-16M110	150	127	122	62	93	10019S
115	Z-16M115	155	127	122	57	91	10019S

SIX POINT IMPACT SOCKETS

DEEP METRIC SIZES



SIZE	PART#	D1	D2	L	T	C	RET RING
19	Z-16M19L	36	54	100	9.5	71	10008S
20	Z-16M20L	37	54	100	10	71	10008S
21	Z-16M21L	38	54	100	10	71	10008S
22	Z-16M22L	40	54	100	10	71	10008S
23	Z-16M23L	41	54	100	12	71	10008S
24	Z-16M24L	42	54	100	12	71	10008S
25	Z-16M25L	43	54	100	13	71	10008S
26	Z-16M26L	45	54	100	13	71	10008S
27	Z-16M27L	46	54	100	13	71	10008S
28	Z-16M28L	47	54	100	14	71	10008S
29	Z-16M29L	48	54	100	14	71	10008S
30	Z-16M30L	50	54	100	16.5	71	10008S
31	Z-16M31L	51	54	100	16.5	71	10008S
32	Z-16M32L	51	54	100	16.5	71	10008S
33	Z-16M33L	54	54	100	17	71	10008S
34	Z-16M34L	54	54	100	19	71	10008S
35	Z-16M35L	54	54	100	19	71	10010S
36	Z-16M36L	54	54	100	19	71	10010S
37	Z-16M37L	57	54	100	19	71	10010S
38	Z-16M38L	60	54	100	22	71	10010S
39	Z-16M39L	60	54	100	21.5	71	10015S
40	Z-16M40L	63	54	100	21.5	71	10015S
41	Z-16M41L	63	54	100	22	71	10015S
42	Z-16M42L	63	54	100	21.5	71	10015S
43	Z-16M43L	67	54	100	25	71	10015S
44	Z-16M44L	67	54	100	21.5	71	10016S
45	Z-16M45L	70	54	100	21.5	71	10016S
46	Z-16M46L	70	54	100	25.5	71	10016S
47	Z-16M47L	70	54	100	23.5	71	10016S
48	Z-16M48L	73	54	100	23.5	71	10016S
49	Z-16M49L	73	54	100	27	71	10016S
50	Z-16M50L	73	54	100	23.5	71	10016S
51	Z-16M51L	73	54	100	27	71	10016S
52	Z-16M52L	78	54	100	27	71	10016S
54	Z-16M54L	82	54	104	30	75	10016S
55	Z-16M55L	82	54	104	27	75	10016S
56	Z-16M56L	82	54	105	28	76	10016S
57	Z-16M57L	82	54	105	33	76	10016S
58	Z-16M58L	86	54	105	28	76	10016S
59	Z-16M59L	86	54	112	33	83	10016S
60	Z-16M60L	86	54	105	28	83	10016S
61	Z-16M61L	88	54	112	28	83	10017S
62	Z-16M62L	92	54	118	35	89	10017S
65	Z-16M65L	92	54	118	35	89	10017S
67	Z-16M67L	92	54	118	38	89	10017S
70	Z-16M70L	96	54	124	38	95	10017S
73	Z-16M73L	100	86	124	41	95	10017S
75	Z-16M75L	100	86	124	41	95	10017S
76	Z-16M76L	105	86	130	44	101	10017S
80	Z-16M80L	105	86	132	37	103	10017S
85	Z-16M85L	115	86	132	40	103	10017S
86	Z-16M86L	115	86	140	49	111	10017S
90	Z-16M90L	127	86	140	43	111	10017S
95	Z-16M95L	135	86	140	49	111	10019S
100	Z-16M100L	135	86	143	54	114	10019S
105	Z-16M105L	145	127	143	54	114	10019S
110	Z-16M110L	150	127	149	62	120	10019S
115	Z-16M115L	155	127	149	57	120	10019S

1" SQUARE DRIVE

HEX DRIVER SOCKETS

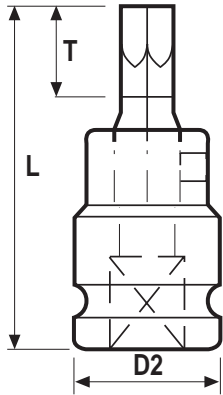

FRACTIONAL SIZES

SIZE	PART#	D2	L	T	RET RING
1/2	Z-1608H	2.125	2.91	1.16	10008S
9/16	Z-1609H	2.125	2.91	1.16	10008S
5/8	Z-1610H	2.125	2.91	1.16	10008S
3/4	Z-1612H	2.125	2.91	1.16	10008S
13/16	Z-1613H	2.125	3.07	1.32	10008S
7/8	Z-1614H	2.125	3.07	1.32	10008S
1	Z-1616H	2.125	3.07	1.32	10008S
1-1/16	Z-1617H	2.125	3.23	1.48	10008S
1-1/8	Z-1618H	2.125	3.23	1.48	10008S
1-3/16	Z-1619H	2.125	3.23	1.48	10008S
1-1/4	Z-1620H	2.125	3.43	1.68	10008S

Note: 1 Piece Construction

METRIC SIZES

SIZE	PART#	D2	L	T	RET RING
10	Z-16M10H	2.125	2.91	1.16	10008S
12	Z-16M12H	2.125	2.91	1.16	10008S
14	Z-16M14H	2.125	2.91	1.16	10008S
17	Z-16M17H	2.125	2.91	1.16	10008S
19	Z-16M19H	2.125	2.91	1.16	10008S
22	Z-16M22H	2.125	3.07	1.32	10008S
24	Z-16M24H	2.125	3.07	1.32	10008S
27	Z-16M27H	2.125	3.23	1.48	10008S
30	Z-16M30H	2.125	3.23	1.48	10008S
32	Z-16M32H	2.125	3.43	1.68	10008S

Note: 1 Piece Construction

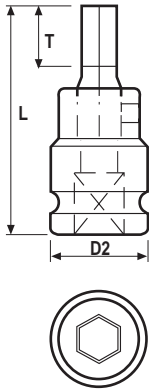

2 PART INHEX

NOMINAL OPENING		Part #	D2	L	T	Weight	Ret	Replacement
mm	A/F Inch							
	1/2"	Z-1608V	54	74	19	800	10008S	H08
	9/16"	Z-1609V	54	74	21	800	10008S	H09
	5/8"	Z-1610V	54	74	24	800	10008S	H10
	3/4"	Z-1612V	54	74	26	800	10008S	H12
	13/16"	Z-1613V	54	89	26	900	10008S	H13
	7/8"	Z-1614V	54	89	26	900	10008S	H14
	1"	Z-1616V	54	109	30	1000	10008S	H16
	1-1/6"	Z-1617V	54	111	32	1000	10008S	H17
	1-1/8"	Z-1618V	54	111	32	1000	10008S	H18
	1-3/16"	Z-1619V	54	115	36	1000	10008S	H19
	1-1/4"	Z-1620V	54	117	38	1000	10008S	H20
10		Z-16M10V	54	74	16	800	10008S	HM10
12		Z-16M12V	54	74	18	800	10008S	HM12
14		Z-16M14V	54	74	21	800	10008S	HM14
17		Z-16M17V	54	74	26	800	10008S	HM17
19		Z-16M19V	54	89	26	900	10008S	HM19
22		Z-16M22V	54	89	26	900	10008S	HM22
24		Z-16M24V	54	89	26	900	10008S	HM24
27		Z-16M27V	54	111	32	1000	10008S	HM27
30		Z-16M30V	54	115	36	1000	10008S	HM30
32		Z-16M32V	54	117	38	1000	10008S	HM32

Note: 2 Piece Construction

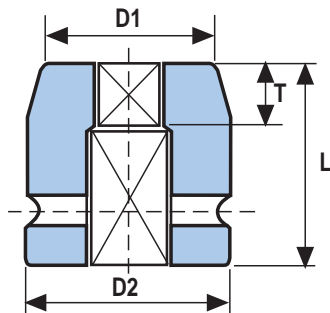

BUDD WHEEL SOCKETS

SIZE	PART#	D1	D2	L	T	RR*
17	Z-16M17B	40	54	55	9	10008S
21	Z-16M21B	47	54	55	10	10008S
13/16	Z-1613B	1.85	2.125	2.145	0.472	10008S
15/16	Z-1615B	2.07	2.125	2.340	0.512	10008S
13/16	Z-1613BL	1.85	2.125	3.900	0.472	10008S
15/16	Z-1615BL	2.07	2.125	3.900	0.512	10008S
13/16 X 1-1/2	Z-1624BS	2.24	2.125	3.900	0.571	10015S

Note: 1-1/2 Deep. Z-1624 M38 LR with poly protective ring.

1" SQUARE DRIVE

12 POINT IMPACT SOCKETS

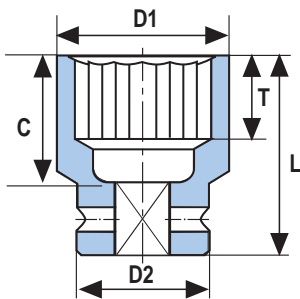

12 POINT IMPACT SOCKETS

NOMINAL OPENING	D1	D2	L	tmin	Weight	Ret
mm A/F Inch CATALOG No.	mm	mm	mm	mm	gr	Ring
19 3/4"	DH-1612DM19	36	54	55	9.5	600 10008S
13/16"	DH-1613	38	54	55	11.0	600 10008S
7/8"	DH-1614	40	54	55	13.0	600 10008S
15/16"	DH-1615	41	54	55	13.0	600 10008S
1"	DH-1616	43	54	55	13.0	600 10008S
27 1-1/16"	DH-1617M27	46	54	55	13.0	600 10008S
1-1/8"	DH-1618	48	54	57	16.5	630 10008S
30 1-3/16"	DH-1619M30	50	54	57	16.5	630 10008S
1-1/4"	DH-1620	51	54	57	17.0	630 10008S
1-5/16"	DH-1621	54	54	60	19.0	650 10008S
35 1-3/8"	DH-1622M35	54	54	60	19.0	650 10010S
1-7/16"	DH-1623	54	54	60	19.0	650 10010S
38 1-1/2"	DH-1624M38	60	54	64	22.0	760 10010S
1-9/16"	DH-1625	60	54	64	22.0	760 10010S
41 1-5/8"	DH-1626M41	63	54	64	22.0	800 10010S
43 1-11/16"	DH-1627M43	67	54	69	25.0	950 10010S



DOUBLE SQUARE IMPACT EIGHT POINT SOCKETS

STANDARD FRACTIONAL SIZES

SIZE	PART#	D1	D2	L	T	C	RET RING
1-5/16	DS-1621	2.480	2.126	2.262	0.748	1.283	10008S
1-3/8	DS-1622	2.638	2.362	2.262	0.748	1.283	10008S
1-7/16	DS-1623	2.638	2.362	2.262	0.748	1.283	10015S
1-1/2	DS-1624	2.756	2.362	2.418	0.866	1.441	10015S
1-9/16	DS-1625	3.071	2.362	2.418	0.866	1.441	10015S
1-5/8	DS-1626	3.071	2.362	2.418	0.866	1.441	10015S
1-11/16	DS-1627	3.228	2.362	2.613	0.984	1.638	10016S
1-3/4	DS-1628	3.228	2.362	2.613	1.005	1.638	10016S
1-13/16	DS-1629	3.386	2.362	2.613	1.005	1.638	10016S
1-7/8	DS-1630	3.386	2.362	2.730	1.063	1.756	10016S
2	DS-1632	3.622	2.362	2.730	1.063	1.756	10016S
2-1/8	DS-1634	3.937	2.362	2.925	1.181	1.953	10017S
2-3/16	DS-1635	3.937	2.362	3.042	1.260	2.071	10017S
2-1/4	DS-1636	3.937	2.362	3.042	1.260	2.071	10017S
2-3/8	DS-1638	4.134	2.362	3.198	1.378	2.228	10017S
2-1/2	DS-1640	4.291	2.362	3.432	1.378	2.465	10017S

Metric sizes 35, 38, 41, 43, 46, 51, 54, 57 are also available by special order. (POA)

12 POINT IMPACT SOCKETS Cont.

NOMINAL OPENING	D1	D2	L	tmin	Weight	Ret	
mm A/F Inch CATALOG No.	mm	mm	mm	mm	gr	Ring	
46 1-3/4"	DH-1628	70	54	69	25.5	1000	10015S
1-13/16"	DH-1629M46	70	54	69	25.5	1000	10015S
1-7/8"	DH-1630	70	54	72	27.0	1000	10015S
49 1-15/16"	DH-1631M49	73	54	72	27.0	1080	10015S
51 2"	DH-1632M51	73	54	72	27.0	2080	10015S
54 2-1/16"	DH-1633	78	54	76	30.0	1240	10015S
2-1/8"	DH-1634M54	82	54	76	30.0	1400	10015S
2-3/16"	DH-1635	82	54	80	32.0	1400	10015S
57 2-1/4"	DH-1636M57	82	54	80	33.0	1400	10015S
59 2-5/16"	DH-1637M59	86	54	82	33.0	1500	10015S
2-3/8"	DH-1638	86	54	85	35.0	1500	10015S
62 2-7/16"	DH-1639M62	92	54	85	35.0	1800	10017S
2-1/2"	DH-1640	92	54	85	35.0	1800	10017S
65 2-9/16"	DH-1641M65	92	54	85	25.0	1800	10017S
67 2-5/8"	DH-1642M67	92	54	88	38.0	1800	10017S
2-11/16"	DH-1643	96	54	88	38.0	1800	10017S
70 2-3/4"	DH-1644M70	96	54	88	38.0	1800	10017S
2-13/16"	DH-1645	100	86	92	40.0	2700	10017S
73 2-7/8"	DH-1646M73	100	86	92	41.0	2700	10017S
75 2-15/16"	DH-1647M75	100	86	92	41.0	2700	10017S
76 3"	DH-1648M76	105	86	97	44.0	3200	10017S
3-1/16"	DH-1649	105	86	97	44.0	3200	10017S
3-1/8"	DH-1650	105	86	97	44.0	3200	10017S
3-3/16"	DH-1651	109	86	100	47.0	3200	10017S
3-1/4"	DH-1652	109	86	100	47.0	3200	10017S
3-5/16"	DH-1653	109	86	100	47.0	3200	10017S
86 3-3/8"	DH-1654M86	115	86	104	49.0	3500	10017S
3-7/16"	DH-1655	121	86	104	49.0	4120	10017S
3-1/2"	DH-1656	121	86	104	49.0	4120	10017S
3-9/16"	DH-1657	127	86	104	49.5	4400	10019S
3-5/8"	DH-1658	130	86	104	49.0	4700	10019S
3-11/16"	DH-1659	130	86	104	49.0	4700	10019S
95 3-3/4"	DH-1660M95	135	86	106	49.0	5200	10019S
3-13/16"	DH-1661	135	86	112	54.0	5200	10019S
3-7/8"	DH-1662	135	86	112	54.0	5200	10019S
100 3-15/16"	DH-1663M100	135	86	112	54.0	5200	10019S
4"	DH-1664	140	127	112	54.0	5500	10019S
4-1/16"	DH-1665	140	127	112	54.0	5500	10019S
105 4-1/8"	DH-1666M105	145	127	112	54.0	7700	10019S
4-3/16"	DH-1667	145	127	122	62.0	8100	10019S
4-1/4"	DH-1668	145	127	122	62.0	8100	10019S
110 4-5/16"	DH-1669M110	150	127	122	62.0	8200	10019S
4-3/8"	DH-1670	150	127	122	62.0	8200	10019S
4-7/16"	DH-1671	150	127	122	62.0	9060	10019S
4-1/2"	DH-1672	150	127	122	62.0	9060	10019S

DEEP FRACTIONAL SIZES

SIZE	PART#	D1	D2	L	T	C	RET RING
1-5/16	DS-1621L	2.480	2.126	3.159	0.748	2.189	10008S
1-3/8	DS-1622L	2.638	2.362	3.159	0.748	2.189	10008S
1-7/16	DS-1623L	2.638	2.362	3.159	0.748	2.189	10015S
1-1/2	DS-1624L	2.756	2.362	3.393	0.866	2.322	10015S
1-9/16	DS-1625L	3.071	2.362	3.432	0.866	2.322	10015S
1-5/8	DS-1626L	3.071	2.362	3.432	0.866	2.322	10015S
1-11/16	DS-1627L	3.228	2.362	3.432	0.984	2.322	10016S
1-3/4	DS-1628L	3.228	2.362	3.432	1.005	2.322	10016S
1-13/16	DS-1629L	3.386	2.362	3.432	1.005	2.322	10016S
1-7/8	DS-1630L	3.386	2.362	3.432	1.063	2.322	10016S
2	DS-1632L	3.622	2.362	3.432	1.063	2.322	10016S
2-1/8	DS-1634L	3.937	2.362	3.783	1.181	2.819	10017S
2-3/16	DS-1635L	3.937	2.362	3.783	1.260	2.819	10017S
2-1/4	DS-1636L	3.937	2.362	3.900	1.260	2.937	10017S
2-3/8	DS-1638L	4.134	2.362	3.900	1.378	2.937	10017S
2-1/2	DS-1640L	4.291	2.362	3.900	1.378	2.937	10017S

Metric sizes 35, 38, 41, 43, 46, 51, 54, 57 are also available by special order. (POA)

1" SQUARE DRIVE

ACCESSORIES

ADAPTERS

PART#	FEMALE	MALE	L	RET RING
A1612	1	3/4	2.750	10008S
A1624	1	1-1/2	3.346	10008S
A1695	1	#5 Spline	4.330	10008S

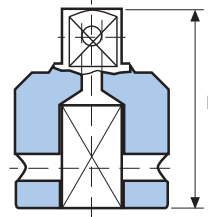

DOUBLE ENDED FEMALE ADAPTERS

PART#	D1	D2	L	RET RINGS	
				A	B
AN1612	1	3/4	2.48	10008S	10032S
AN1616	1	1	2.32	10008S	10008S
AN2416	1	1-1/2	3.27	10008S	10020S

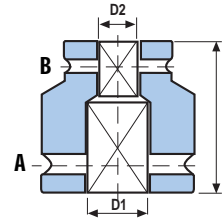

DOUBLE ENDED MALE ADAPTERS

PART#	D1	L
Z1603	1.3	3
Z1604	1.3	4
Z1605	1.3	5
Z1606	1.3	6
Z1607	1.3	7
Z1610	1.3	10
Z1613	1.3	13
Z1615	1.3	15
Z1616	1.3	16
Z1617	1.3	17

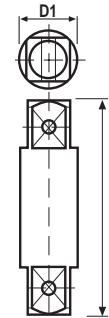

UNIVERSAL JOINT

SIZE	PART#	L	Ret Ring
1	U1616	4.250	10008S

EXTENSIONS

PART#	D1	L	RET RING
E1604	2.125	4	10008S
E1605	2.125	5	10008S
E1607	2.125	7	10008S
E1610	2.125	10	10008S
E1613	2.125	13	10008S

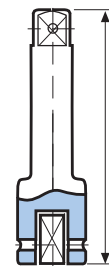

RETAINING PINS AND RINGS

SQUARE DRIVE	THROUGH HEX SIZE	PIN #	RING#	d	L	D
1	2-3/4 - 70mm	P1654	R1654	.195	1.750	1.750
1	3-5/16 - 100mm	P1686	R1686	.195	3.000	3.000
1	Above 3-5/16	P16127	R16127	.195	4.600	4.600

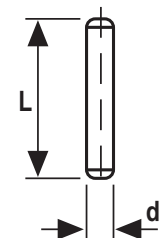
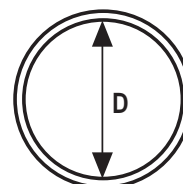

1 1/2" SQUARE DRIVE

SIX POINT IMPACT SOCKETS

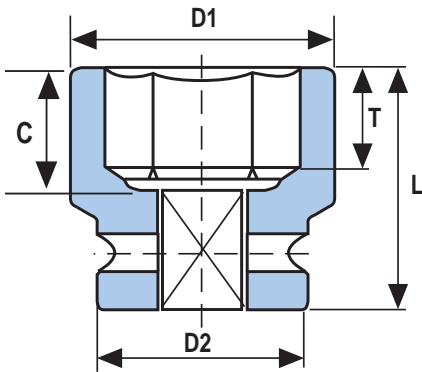

STANDARD FRACTIONAL SIZES

SIZE	PART#	D1	D2	L	T	C	RET
							RING
1-5/16	Z-2421	2.402	3.386	2.925	0.748	1.328	10020S
1-3/8	Z-2422	2.480	3.386	2.925	0.748	1.328	10020S
1-7/16	Z-2423	2.520	3.386	3.120	0.748	1.525	10020S
1-1/2	Z-2424	2.520	3.386	3.120	0.866	1.525	10020S
1-9/16	Z-2425	2.677	3.386	3.120	0.866	1.525	10020S
1-5/8	Z-2426	2.795	3.386	3.120	0.866	1.525	10020S
1-11/16	Z-2427	2.874	3.386	3.120	0.984	1.525	10020S
1-3/4	Z-2428	2.953	3.386	3.120	1.004	1.525	10020S
1-13/16	Z-2429	2.953	3.386	3.120	1.004	1.525	10020S
1-7/8	Z-2430	3.150	3.386	3.198	1.036	1.603	10020S
1-15/16	Z-2431	3.150	3.386	3.198	1.063	1.603	10020S
2	Z-2432	3.150	3.386	3.198	1.063	1.603	10020S
2-1/16	Z-2433	3.386	3.386	3.471	1.181	1.840	10020S
2-1/8	Z-2434	3.386	3.386	3.471	1.181	1.840	10020S
2-3/16	Z-2435	3.386	3.386	3.588	1.260	1.958	10020S
2-1/4	Z-2436	3.386	3.386	3.588	1.280	1.958	10025S
2-5/16	Z-2437	3.622	3.386	3.588	1.300	1.958	10025S
2-3/8	Z-2438	3.622	3.386	3.744	1.378	2.115	10025S
2-7/16	Z-2439	3.780	3.386	3.744	1.378	2.115	10025S
2-1/2	Z-2440	3.937	3.386	3.744	1.378	2.115	10025S
2-9/16	Z-2441	3.937	3.386	3.744	1.378	2.115	10025S
2-5/8	Z-2442	3.937	3.386	3.939	1.496	2.312	10025S
2-11/16	Z-2443	4.134	3.386	3.939	1.496	2.312	10025S
2-3/4	Z-2444	4.134	3.386	3.939	1.496	2.312	10025S
2-13/16	Z-2445	4.291	3.386	4.095	1.575	2.509	10025S
2-7/8	Z-2446	4.291	3.386	4.095	1.614	2.509	10025S
2-15/16	Z-2447	4.291	3.386	4.095	1.614	2.509	10025S
3	Z-2448	4.528	3.386	4.290	1.732	2.706	10025S
3-1/16	Z-2449	4.528	3.386	4.290	1.732	2.706	10025S
3-1/8	Z-2450	4.528	3.386	4.290	1.770	2.706	10025S
3-3/16	Z-2451	4.764	3.386	4.524	1.850	3.099	10025S
3-1/4	Z-2452	4.764	3.386	4.524	1.850	3.099	10025S
3-5/16	Z-2453	4.764	3.386	4.524	1.850	3.099	10025S
3-3/8	Z-2454	5.000	3.386	4.524	1.930	3.099	10025S
3-7/16	Z-2455	5.000	3.386	4.602	1.930	3.099	10025S
3-1/2	Z-2456	5.118	3.386	4.602	1.930	3.099	10025S
3-9/16	Z-2457	5.118	3.386	4.602	1.930	3.099	10025S
3-5/8	Z-2458	5.315	5.000	4.602	1.930	3.099	10025S
3-11/16	Z-2459	5.315	5.000	4.602	1.930	3.099	10025S
3-3/4	Z-2460	5.315	5.000	4.602	1.930	3.296	10025S
3-13/16	Z-2461	5.512	5.000	4.875	2.125	3.296	10025S
3-7/8	Z-2462	5.512	5.000	4.875	2.125	3.296	10025S
3-15/16	Z-2463	5.512	5.000	4.875	2.125	3.296	10025S
4	Z-2464	5.709	5.000	4.875	2.125	3.296	10025S
4-1/16	Z-2465	5.709	5.000	4.875	2.125	3.296	10035S
4-1/8	Z-2466	5.906	5.000	4.875	2.126	3.296	10035S
4-3/16	Z-2467	5.906	5.000	5.343	2.440	3.296	10035S
4-1/4	Z-2468	5.906	5.000	5.343	2.440	3.690	10035S
4-5/16	Z-2469	6.102	5.000	5.343	2.440	3.690	10035S
4-3/8	Z-2470	6.102	5.000	5.343	2.440	3.690	10035S
4-7/16	Z-2471	6.102	5.000	5.343	2.440	3.690	10035S
4-1/2	Z-2472	6.299	5.000	5.343	2.440	3.690	10035S
4-5/8	Z-2474	6.496	5.000	5.577	2.640	4.084	10035S
4-3/4	Z-2476	6.693	5.000	5.655	2.640	4.084	10035S
4-7/8	Z-2478	6.693	5.000	5.655	2.640	4.084	10035S
5	Z-2480	7.087	5.000	5.850	2.830	4.281	10035S
5-1/8	Z-2482	7.087	5.000	6.162	2.990	4.674	10035S
5-3/16	Z-2483	7.087	5.000	6.162	2.990	4.674	10035S
5-1/4	Z-2484	7.480	5.000	6.162	2.980	4.574	10035S
5-3/8	Z-2486	7.480	5.000	6.162	2.990	4.674	10035S

1 1/2" SQUARE DRIVE

SIX POINT IMPACT SOCKETS

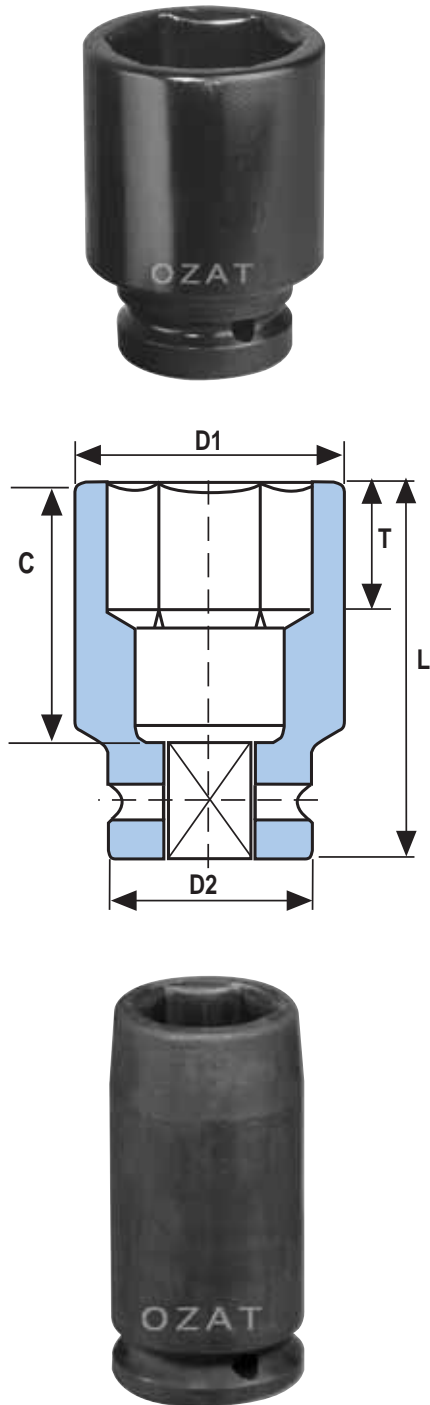

The exceptional strength of the OZAT 1-1/2" drive sockets often makes them the preferred choice of hydraulic bolting specialists.

Speciality sockets for the precision bolting market are available from ATP.

DEEP FRACTIONAL SIZES



SIZE	PART#	D1	D2	L	T	C	RET RING
1-5/16	Z-2421L	2.402	3.386	5.460	0.748	3.887	10020S
1-3/8	Z-2422L	2.480	3.386	5.460	0.748	3.887	10020S
1-7/16	Z-2423L	2.520	3.386	5.460	0.748	3.887	10020S
1-1/2	Z-2424L	2.520	3.386	5.460	0.866	3.887	10020S
1-9/16	Z-2425L	2.677	3.386	5.460	0.866	3.887	10020S
1-5/8	Z-2426L	2.795	3.386	5.460	0.866	3.887	10020S
1-11/16	Z-2427L	2.874	3.386	5.460	0.984	3.887	10020S
1-3/4	Z-2428L	2.953	3.386	5.460	1.004	3.887	10020S
1-13/16	Z-2429L	2.953	3.386	5.460	1.004	3.887	10020S
1-7/8	Z-2430L	3.150	3.386	5.460	1.036	3.887	10020S
1-15/16	Z-2431L	3.150	3.386	5.460	1.063	3.887	10020S
2	Z-2432L	3.150	3.386	5.460	1.063	3.887	10020S
2-1/16	Z-2433L	3.386	3.386	5.460	1.181	3.887	10020S
2-1/8	Z-2434L	3.386	3.386	5.460	1.181	3.887	10020S
2-3/16	Z-2435L	3.386	3.386	5.460	1.260	3.887	10020S
2-1/4	Z-2436L	3.386	3.386	5.460	1.280	3.887	10025S
2-5/16	Z-2437L	3.622	3.386	5.460	1.300	3.887	10025S
2-3/8	Z-2438L	3.622	3.386	5.460	1.378	3.887	10025S
2-7/16	Z-2439L	3.780	3.386	5.460	1.378	3.887	10025S
2-1/2	Z-2440L	3.937	3.386	5.460	1.378	3.887	10025S
2-9/16	Z-2441L	3.937	3.386	5.460	1.378	3.887	10025S
2-5/8	Z-2442L	3.937	3.386	5.460	1.496	3.887	10025S
2-11/16	Z-2443L	4.134	3.386	5.460	1.496	3.887	10025S
2-3/4	Z-2444L	4.134	3.386	5.460	1.496	3.887	10025S
2-13/16	Z-2445L	4.291	3.386	5.460	1.575	3.887	10025S
2-7/8	Z-2446L	4.291	3.386	5.460	1.614	3.887	10025S
2-15/16	Z-2447L	4.291	3.386	5.460	1.614	3.887	10025S
3	Z-2448L	4.528	3.386	5.460	1.732	3.887	10025S
3-1/16	Z-2449L	4.528	3.386	5.460	1.732	3.887	10025S
3-1/8	Z-2450L	4.528	3.386	5.460	1.770	3.887	10025S
3-3/16	Z-2451L	4.764	3.386	5.460	1.850	3.887	10025S
3-1/4	Z-2452L	4.764	3.386	5.460	1.850	3.887	10025S
3-5/16	Z-2453L	4.764	3.386	5.460	1.850	3.887	10025S
3-3/8	Z-2454L	5.000	3.386	5.460	1.930	3.887	10025S
3-7/16	Z-2455L	5.000	3.386	5.460	1.930	3.887	10025S
3-1/2	Z-2456L	5.118	3.386	5.460	1.930	3.887	10025S
3-9/16	Z-2457L	5.118	3.386	5.460	1.930	3.887	10025S
3-5/8	Z-2458L	5.315	5.000	5.460	1.930	3.887	10025S
3-11/16	Z-2459L	5.315	5.000	5.460	1.930	4.281	10025S
3-3/4	Z-2460L	5.315	5.000	5.850	1.930	4.281	10025S
3-13/16	Z-2461L	5.512	5.000	5.850	2.125	4.281	10025S
3-7/8	Z-2462L	5.512	5.000	5.850	2.125	4.281	10025S
3-15/16	Z-2463L	5.512	5.000	5.850	2.125	4.281	10025S
4	Z-2464L	5.709	5.000	5.850	2.125	4.281	10025S
4-1/16	Z-2465L	5.709	5.000	5.850	2.125	4.281	10035S
4-1/8	Z-2466L	5.906	5.000	5.850	2.126	4.281	10035S
4-3/16	Z-2467L	5.906	5.000	5.850	2.440	4.281	10035S
4-1/4	Z-2468L	5.906	5.000	6.240	2.440	4.674	10035S
4-5/16	Z-2469L	6.102	5.000	6.240	2.440	4.674	10035S
4-3/8	Z-2470L	6.102	5.000	6.240	2.440	4.674	10035S
4-7/16	Z-2471L	6.102	5.000	6.240	2.440	4.674	10035S
4-1/2	Z-2472L	6.299	5.000	6.240	2.440	4.674	10035S
4-5/8	Z-2474L	6.496	5.000	6.630	2.640	5.068	10035S
4-3/4	Z-2476L	6.693	5.000	6.630	2.640	5.068	10035S
4-7/8	Z-2478L	6.693	5.000	6.630	2.640	5.068	10035S
5	Z-2480L	7.087	5.000	7.020	2.830	5.462	10035S
5-1/8	Z-2482L	7.087	5.000	7.215	2.990	5.658	10035S
5-3/16	Z-2483L	7.087	5.000	7.215	2.990	5.658	10035S
5-3/8	Z-2486L	7.480	5.000	7.215	2.990	5.658	10035S

STANDARD METRIC SIZES



SIZE	PART#	D1	D2	L	T	C	RET RING
32	Z-24M32	60	86	75	16.5	34	10020S
33	Z-24M33	60	86	75	17	34	10020S
34	Z-24M34	60	86	75	17	34	10020S
35	Z-24M35	60	86	75	19	34	10020S
36	Z-24M36	64	86	80	19	39	10020S
37	Z-24M37	64	86	80	19	39	10020S
38	Z-24M38	64	86	80	22	39	10020S
39	Z-24M39	70	86	80	21.5	39	10020S
40	Z-24M40	70	86	80	21.5	39	10020S
41	Z-24M41	70	86	80	22	39	10020S
42	Z-24M42	70	86	80	21.5	39	10020S
43	Z-24M43	75	86	80	25	39	10020S
44	Z-24M44	75	86	80	21.5	39	10020S
45	Z-24M45	75	86	80	21.5	39	10020S
46	Z-24M46	75	86	80	25.5	39	10020S
47	Z-24M47	75	86	80	23.5	39	10020S
48	Z-24M48	80	86	82	23.5	41	10020S
49	Z-24M49	80	86	82	27	41	10020S
50	Z-24M50	80	86	82	23.5	41	10020S
51	Z-24M51	80	86	82	27	41	10020S
52	Z-24M52	80	86	82	27	41	10020S
54	Z-24M54	86	86	89	30	47	10020S
55	Z-24M55	86	86	89	27	47	10020S
56	Z-24M56	86	86	92	28	50	10020S
57	Z-24M57	86	86	92	32.5	50	10020S
58	Z-24M58	92	86	92	28	50	10020S
59	Z-24M59	92	86	92	33	50	10020S
60	Z-24M60	92	86	92	28	50	10020S
61	Z-24M61	96	86	96	28	54	10025S
62	Z-24M62	96	86	96	35	54	10025S
65	Z-24M65	100	86	96	35	54	10025S
67	Z-24M67	100	86	101	38	59	10025S
70	Z-24M70	105	86	101	38	59	10025S
73	Z-24M73	109	86	105	41	64	10025S
75	Z-24M75	109	86	105	41	64	10025S
76	Z-24M76	115	86	110	44	69	10025S
80	Z-24M80	115	86	110	37	69	10025S
85	Z-24M85	121	86	116	40	79	10025S
86	Z-24M86	127	86	116	49	79	10025S
90	Z-24M90	130	86	118	43	79	10025S
95	Z-24M95	135	127	118	49	84	10025S
100	Z-24M100	140	127	125	54	84	10025S
105	Z-24M105	150	127	125	54	84	10035S
110	Z-24M110	155	127	137	62	94	10035S
115	Z-24M115	160	127	137	57	94	10035S
120	Z-24M120	165	127	145	67	104	10035S
125	Z-24M125	170	127	145	67	104	10035S
130	Z-24M130	180	127	158	76	119	10035S

DEEP METRIC SIZES



SIZE	PART#	D1	D2	L	T	C	RET RING
32	Z-24M32L	60	86	140	16.5	99	10020S
33	Z-24M33L	60	86	140	17	99	10020S
34	Z-24M34L	60	86	140	17	99	10020S
35	Z-24M35L	60	86	140	19	99	10020S
36	Z-24M36L	64	86	140	19	99	10020S
37	Z-24M37L	64	86	140	19	99	10020S
38	Z-24M38L	64	86	140	22	99	10020S
39	Z-24M39L	70	86	140	21.5	99	10020S
40	Z-24M40L	70	86	140	21.5	99	10020S
41	Z-24M41L	70	86	140	22	99	10020S
42	Z-24M42L	70	86	140	21.5	99	10020S
43	Z-24M43L	75	86	140	25	99	10020S
44	Z-24M44L	75	86	140	21.5	99	10020S
45	Z-24M45L	75	86	140	21.5	99	10020S
46	Z-24M46L	75	86	140	25.5	99	10020S
47	Z-24M47L	75	86	140	23.5	99	10020S
48	Z-24M48L	80	86	140	23.5	99	10020S
49	Z-24M49L	80	86	140	27	99	10020S
50	Z-24M50L	80	86	140	23.5	99	10020S
51	Z-24M51L	80	86	140	27	99	10020S
52	Z-24M52L	80	86	140	27	99	10020S
54	Z-24M54L	86	86	140	30	99	10020S
55	Z-24M55L	86	86	140	27	99	10020S
56	Z-24M56L	86	86	140	28	99	10020S
57	Z-24M57L	86	86	140	32.5	99	10020S
58	Z-24M58L	92	86	140	28	99	10020S
59	Z-24M59L	92	86	140	33	99	10020S
60	Z-24M60L	92	86	140	28	99	10020S
61	Z-24M61L	96	86	140	28	99	10025S
62	Z-24M62L	96	86	140	35	99	10025S
65	Z-24M65L	100	86	140	35	99	10025S
67	Z-24M67L	100	86	140	38	99	10025S
70	Z-24M70L	105	86	140	38	99	10025S
73	Z-24M73L	109	86	140	41	99	10025S
75	Z-24M75L	109	86	140	41	99	10025S
76	Z-24M76L	115	86	140	44	99	10025S
80	Z-24M80L	115	86	140	37	99	10025S
85	Z-24M85L	121	86	140	40	99	10025S
86	Z-24M86L	127	86	140	49	99	10025S
90	Z-24M90L	130	86	140	43	99	10025S
95	Z-24M95L	135	127	150	49	109	10025S
100	Z-24M100L	140	127	150	54	109	10025S
105	Z-24M105L	150	127	150	54	109	10035S
110	Z-24M110L	155	127	160	62	119	10035S
115	Z-24M115L	160	127	160	57	119	10035S
120	Z-24M120L	165	127	170	67	129	10035S
125	Z-24M125L	170	127	170	67	129	10035S
130	Z-24M130L	180	127	185	76	144	10035S

1½" SQUARE DRIVE

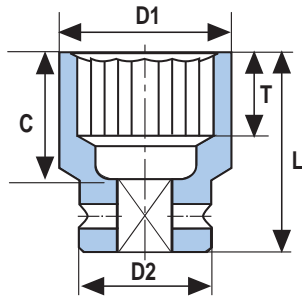

2 PART INHEX

NOMINAL OPENING			D2	L	T	Weight
mm	A/F Inch	Part #*	mm	mm	mm	gr
22		Z-24M22V	86	113	22	2600
24		Z-24M24V	86	115	24	2600
27		Z-24M27V	86	118	27	2600
30		Z-24M30V	86	121	30	2800
32		Z-24M32V	86	123	32	2800
36		Z-24M36V	86	127	36	3400
38		Z-24M38V	86	129	38	3400
41		Z-24M41V	86	132	41	3520
46		Z-24M46V	86	137	46	4700
50		Z-24M50V	86	141	50	4900
55		Z-24M55V	86	146	55	5100
	1"	Z-2416V	86	116	25	2600
	1-1/8"	Z-2418V	86	119	28	2600
	1-1/4"	Z-2420V	86	123	32	2800
	1-3/8"	Z-2422V	86	126	35	3400
	1-1/2"	Z-2424V	86	129	38	3400
	1-5/8"	Z-2426V	86	132	41	3520
	1-3/4"	Z-2428V	86	135	44	3520
	1-13/16"	Z-2429V	86	137	46	4700
	1-7/8"	Z-2430V	86	139	48	4900
	2"	Z-2432V	86	142	51	4900
	2-1/8"	Z-2434V	86	145	54	5100

Note: 2 Piece Construction

Replacement Hex Bits

PART#*	BIT#	RR*
Z-24M22V	HM22	10020S
Z-24M24V	HM24	10020S
Z-24M27V	HM27	10020S
Z-24M30V	HM30	10020S
Z-24M32V	HM32	10020S
Z-24M36V	HM36	10020S
Z-24M38V	HM38	10020S
Z-24M41V	HM41	10020S
Z-24M46V	HM46	10020S
Z-24M50V	HM50	10020S
Z-24M55V	HM55	10020S
Z-2416V	H16	10020S
Z-2418V	H18	10020S
Z-2420V	H20	10020S
Z-2422V	H22	10020S
Z-2424V	H24	10020S
Z-2426V	H26	10020S
Z-2428V	H28	10020S
Z-2429V	H29	10020S
Z-2430V	H30	10020S
Z-2432V	H32	10020S
Z-2434V0	H34	10020S

*RR - Retainer Ring

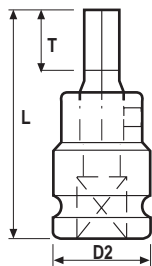

12 POINT IMPACT SOCKETS

12 POINT IMPACT SOCKETS



NOMINAL OPENING			D1	D2	L	tmin	Weight	Ret
mm	A/F Inch	CATALOG No.	mm	mm	mm	mm	gr	Ring
	1-5/16	DH-2421	60	86	75	19	1800	10020S
35	1-3/8	DH-2422M35	60	86	75	19	1800	10020S
	1-7/16	DH-2423	64	86	80	19	2200	10020S
38	1-1/2	DH-2424M38	64	86	80	22	2200	10020S
	1-9/16	DH-2425	70	86	80	22	2200	10020S
41	1-5/8	DH-2426M41	70	86	80	22	2200	10020S
43	1-11/16	DH-2427M43	75	86	80	25	2200	10020S
	1-3/4	DH-2428	75	86	80	25.5	2200	10020S
46	1-13/16	DH-2429M46	75	86	80	25.5	2200	10020S
	1-7/8	DH-2430	80	86	82	27	2300	10020S
49	1-15/16	DH-2431M49	80	86	82	27	2300	10020S
	2	DH-2432M51	80	86	82	27	2300	10020S
	2-1/16	DH-2433	86	86	89	30	2500	10020S
54	2-1/8	DH-2434M54	86	86	89	30	2500	10020S
		DH-24M55	86	86	89	30	2500	10020S
	2-3/16	DH-2435	86	86	92	32	2500	10020S
57	2-1/4	DH-2436M57	86	86	92	32.5	2500	10020S
59	2-5/16	DH-2437M59	92	86	92	33	280	10020S
	2-3/8	DH-2438	92	86	96	35	2800	10020S
62	2-7/16	DH-2439M62	96	86	96	35	3200	10025S
	2-1/2	DH-2440	100	86	96	35	3350	10025S
65	2-9/16	DH-2441M65	100	86	96	35	3350	10025S
67	2-5/8	DH-2442M67	100	86	101	38	3350	10025S
70	2-3/4	DH-2444M70	105	86	101	38	3600	10025S
73	2-7/8	DH-2446M73	105	86	101	44	3900	10025S
75	2-15/16	DH-2447M75	105	86	101	44	3900	10025S
	2-13/16	DH-2445	105	86	105	44	3900	10025S
76	3	DH-2448M76	115	86	110	44	4500	10025S
	3-1/8	DH-2450	115	86	110	44	4500	10025S
	3-3/16"	DH-2451	121	86	116	47	5100	10025S
	3-1/4"	DH-2452	121	86	116	47	5100	10025S
	3-5/16"	DH-2453	121	86	116	47	5100	10025S
86	3-3/8"	DH-2454M86	127	86	116	49	5500	10025S
	3-7/16"	DH-2455	127	86	118	49	5500	10025S
	3-1/2"	DH-2456	130	86	118	49	5600	10025S
	3-9/16"	DH-2457	130	86	118	49	5600	10025S
	3-5/8"	DH-2458	135	127	118	49	7900	10025S
	3-11/16"	DH-2459	135	127	118	49	7900	10025S
95	3-3/4"	DH-2460M95	135	127	118	49	7900	10025S
	3-13/16"	DH-2461	140	127	125	54	8500	10025S
	3-7/8"	DH-2462	140	127	125	54	8500	10025S
100	3-15/16	DH-2463M100	140	127	125	54	8500	10025S
	4"	DH-2464	145	127	125	54	9000	10025S
	4-1/16"	DH-2465	145	127	125	54	9000	10035S
105	4-1/8"	DH-2466M105	150	127	125	54	9500	10035S
	4-3/16"	DH-2467	150	127	137	54	10200	10035S
	4-1/4"	DH-2468	150	127	137	62	10200	10035S
110	4-5/16"	DH-2469M110	155	127	137	62	10400	10035S
	4-3/8"	DH-2470	155	127	137	62	10400	10035S
	4-7/16"	DH-2471	155	127	137	62	10400	10035S
	4-1/2"	DH-2472	160	127	137	62	11500	10035S
	4-5/8"	DH-2474	165	127	143	67	12000	10035S
	4-3/4"	DH-2476	165	127	145	67	12000	10035S
	4-7/8"	DH-2478	170	127	145	67	12200	10035S
	5"	DH-2480	180	127	150	72	14800	10035S
130	5-1/8"	DH-2482M130	180	127	158	76	14800	10035S
	5-3/16"	DH-2483	180	127	158	76	14800	10035S
	5-3/8"	DH-2486	190	127	158	76	16700	10035S

1 1/2" SQUARE DRIVE

ACCESSORIES

ADAPTERS

PART#	FEMALE	MALE	L	RET RING
A2416	1-1/2	1	3.75	10020S
A2440	1-1/2	2-1/2	3.50	10020S
A2495	1-1/2	#5 Spline	4.33	10020S

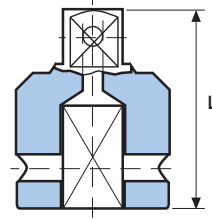

DOUBLE ENDED FEMALE ADAPTERS

PART#	D1	D2	L	RET RINGS	
				A	B
AN2416	1-1/2	1	3.27	10020S	10008S
AN2424	1-1/2	1-1/2	3.35	10020S	10020S
AN4024	1-1/2	2-1/2	4.53	10020S	10035S

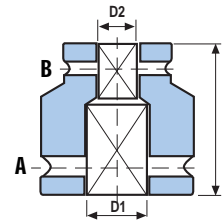

DOUBLE ENDED MALE ADAPTERS

PART#	D1	L
Z2404	1.93	4
Z2405	1.93	5
Z2410	1.93	10
Z2420	1.93	20

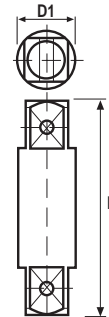

UNIVERSAL JOINT

SIZE	PART#	RR*
1-1/2	U2424	10020S

EXTENSIONS

PART#	L	RR*
E2406	6	10020S
E2412	12	10020S

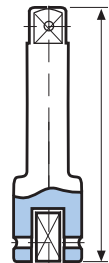

RETAINING PINS AND RINGS

SQUARE DRIVE	THROUGH HEX SIZE	PIN #	RING#	d	L	D
1-1/2	3-9/16 - 90mm	P2486	R2486	.234	2.925	2.925
1-1/2	Above 3-9/16	P24127	R24127	.234	4.525	4.525

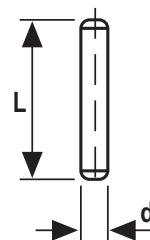
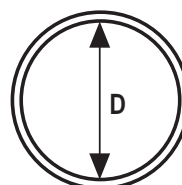

2 1/2" SQUARE DRIVE

STANDARD FRACTIONAL SIZES

SIZE	PART#	D1	D2	L	T	C
1-5/8	Z-4026	4.094	5.000	4.485	0.846	2.349
1-11/16	Z-4027	4.094	5.000	4.485	0.984	2.349
1-3/4	Z-4028	4.094	5.000	4.485	1.000	2.349
1-13/16	Z-4029	4.094	5.000	4.485	1.000	2.349
1-7/8	Z-4030	4.094	5.000	4.485	1.062	2.349
1-15/16	Z-4031	4.094	5.000	4.485	1.062	2.349
2	Z-4032	4.094	5.000	4.485	1.062	2.349
2-1/16	Z-4033	4.094	5.000	4.485	1.181	2.349
2-1/8	Z-4034	4.094	5.000	4.485	1.181	2.349
2-3/16	Z-4035	4.094	5.000	4.485	1.260	2.349
2-1/4	Z-4036	4.094	5.000	4.485	1.280	2.349
2-5/16	Z-4037	4.094	5.000	4.485	1.299	2.349
2-3/8	Z-4038	4.094	5.000	4.485	1.378	2.349
2-7/16	Z-4039	4.094	5.000	4.485	1.378	2.349
2-1/2	Z-4040	4.094	5.000	4.485	1.378	2.349
2-9/16	Z-4041	4.094	5.000	4.485	1.378	2.349
2-5/8	Z-4042	4.094	5.000	4.485	1.496	2.349
2-11/16	Z-4043	4.094	5.000	4.485	1.496	2.349
2-3/4	Z-4044	4.094	5.000	4.485	1.496	2.349
2-13/16	Z-4045	4.094	5.000	4.870	1.575	2.349
2-7/8	Z-4046	4.094	5.000	4.870	1.614	2.349
2-15/16	Z-4047	4.094	5.000	4.870	1.614	2.349
3	Z-4048	4.094	5.000	4.870	1.732	2.349
3-1/16	Z-4049	4.094	5.000	4.870	1.732	2.349
3-1/8	Z-4050	4.094	5.000	4.870	1.732	2.349
3-3/16	Z-4051	5.000	5.000	5.070	1.850	2.743
3-1/4	Z-4052	5.000	5.000	5.070	1.850	2.743
3-5/16	Z-4053	5.000	5.000	5.070	1.850	2.743
3-3/8	Z-4054	5.000	5.000	5.070	1.930	2.743
3-7/16	Z-4055	5.315	5.000	5.140	1.930	2.822
3-1/2	Z-4056	5.315	5.000	5.140	1.930	2.822
3-9/16	Z-4057	5.315	5.000	5.140	1.930	2.822
3-5/8	Z-4058	5.315	5.000	5.140	1.930	2.822
3-11/16	Z-4059	5.315	5.000	5.140	1.930	2.822
3-3/4	Z-4060	5.512	5.000	5.140	1.930	2.822
3-13/16	Z-4061	5.709	5.000	5.500	2.125	3.137
3-7/8	Z-4062	5.709	5.000	5.500	2.125	3.137
3-15/16	Z-4063	5.709	5.000	5.500	2.125	3.137
4	Z-4064	5.906	5.000	5.500	2.125	3.137
4-1/16	Z-4065	5.906	5.000	5.500	2.125	3.137
4-1/8	Z-4066	6.102	5.000	5.500	2.125	3.137
4-3/16	Z-4067	6.102	5.000	5.850	2.440	3.491
4-1/4	Z-4068	6.102	5.000	5.850	2.440	3.491
4-5/16	Z-4069	6.299	5.000	5.850	2.440	3.49
4-3/8	Z-4070	6.299	5.000	5.850	2.440	3.491
4-7/16	Z-4071	6.496	5.000	5.850	2.440	3.49
4-1/2	Z-4072	6.496	5.000	5.850	2.440	3.491
4-5/8	Z-4074	6.693	5.000	6.160	2.640	3.806
4-3/4	Z-4076	6.693	5.000	6.160	2.640	3.806
4-7/8	Z-4078	6.693	5.000	6.160	2.640	3.806
5	Z-4080	7.087	5.000	6.435	2.830	4.121
5-1/8	Z-4082	7.087	5.000	6.430	2.990	4.436
5-3/16	Z-4083	7.087	5.000	6.780	2.909	4.436

Table continued next column

SIX POINT IMPACT SOCKETS

STANDARD FRACTIONAL SIZES

SIZE	PART#	D1	D2	L	T	C
5-1/4	Z-4084	7.480	5.000	6.780	2.99	4.436
5-3/8	Z-4086	7.480	5.000	6.780	2.99	4.436
5-1/2	Z-4088	7.480	5.000	6.860	3.11	4.790
5-5/8	Z-4090	7.874	5.906	7.090	3.27	4.790
5-3/4	Z-4092	7.874	5.906	7.090	3.27	4.790
5-7/8	Z-4094	8.268	5.906	7.410	3.46	5.105
6	Z-4096	8.268	5.906	7.410	3.46	5.105
6-1/8	Z-4098	8.268	5.906	7.410	3.46	5.105
6-1/4	Z-40100	8.661	5.906	7.560	3.58	5.263
6-3/8	Z-40102	8.661	5.906	7.560	3.58	5.263
6-1/2	Z-40104	9.055	6.890	7.830	3.70	5.735
6-5/8	Z-40106	9.055	6.890	7.830	3.70	5.735
6-3/4	Z-40108	9.055	6.890	8.110	3.90	5.735
6-7/8	Z-40110	9.449	6.890	8.110	3.90	5.735
7	Z-40112	9.449	6.890	8.340	4.09	6.050
7-1/8	Z-40114	9.843	6.890	8.340	4.09	6.050
7-1/4	Z-40116	9.843	6.890	8.340	4.09	6.050
7-3/8	Z-40118	9.843	6.890	8.500	4.21	6.208
7-1/2	Z-40120	10.236	6.890	8.500	4.21	6.208
7-5/8	Z-40122	10.236	6.890	8.650	4.29	6.365
7-3/4	Z-40124	10.630	6.890	8.810	4.41	6.523
7-13/16	Z-40125	10.630	6.890	8.810	4.41	6.523
7-7/8	Z-40126	10.630	6.890	8.810	4.41	6.523
8	Z-40128	10.630	6.890	9.040	4.53	7.034
8-1/8	Z-40130	11.024	6.890	9.040	4.53	7.034
8-1/4	Z-40132	11.024	6.890	9.040	4.53	7.034
8-3/8	Z-40134	11.417	6.890	9.320	4.72	7.034
8-1/2	Z-40136	11.417	6.890	9.750	4.80	7.782
8-3/4	Z-40140	11.811	6.890	9.870	4.88	7.782
8-7/8	Z-40142	11.811	6.890	10.062	4.96	7.782
9	Z-40144	12.205	6.890	10.062	5.04	7.782
9-1/8	Z-40146	12.205	6.890	10.062	5.16	7.782
9-1/4	Z-40148	12.205	6.890	10.725	5.24	9.515

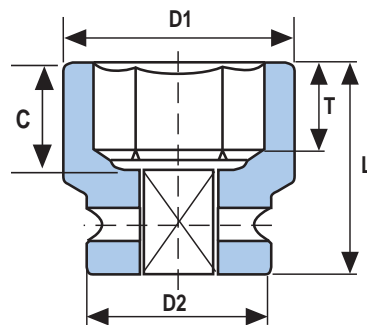

DEEP FRACTIONAL SIZES

SIZE	PART#	D1	D2	L	T	C
1-5/8	Z-4026L	4.094	5.000	7.480	0.846	5.184
1-11/16	Z-4027L	4.094	5.000	7.480	0.984	5.184
1-3/4	Z-4028L	4.094	5.000	7.480	1.000	5.184
1-13/16	Z-4029L	4.094	5.000	7.480	1.000	5.184
1-7/8	Z-4030L	4.094	5.000	7.480	1.062	5.184
1-15/16	Z-4031L	4.094	5.000	7.480	1.062	5.184
2	Z-4032L	4.094	5.000	7.480	1.062	5.184
2-1/16	Z-4033L	4.094	5.000	7.480	1.181	5.184
2-1/8	Z-4034L	4.094	5.000	7.480	1.181	5.184
2-3/16	Z-4035L	4.094	5.000	7.480	1.260	5.184
2-1/4	Z-4036L	4.094	5.000	7.480	1.280	5.184
2-5/16	Z-4037L	4.094	5.000	7.480	1.299	5.184
2-3/8	Z-4038L	4.094	5.000	7.480	1.378	5.184
2-7/16	Z-4039L	4.094	5.000	7.480	1.378	5.184
2-1/2	Z-4040L	4.094	5.000	7.480	1.378	5.184
2-9/16	Z-4041L	4.094	5.000	7.480	1.378	5.184
2-5/8	Z-4042L	4.094	5.000	7.480	1.496	5.184
2-11/16	Z-4043L	4.094	5.000	7.480	1.496	5.184
2-3/4	Z-4044L	4.094	5.000	7.480	1.496	5.184
2-13/16	Z-4045L	4.094	5.000	7.480	1.575	5.184
2-7/8	Z-4046L	4.094	5.000	7.480	1.614	5.184
2-15/16	Z-4047L	4.094	5.000	7.480	1.614	5.184
3	Z-4048L	4.094	5.000	7.480	1.732	5.184
3-1/16	Z-4049L	4.094	5.000	7.480	1.732	5.184
3-1/8	Z-4050L	4.094	5.000	7.480	1.732	5.184
3-3/16	Z-4051L	5.000	5.000	7.480	1.850	5.184
3-1/4	Z-4052L	5.000	5.000	7.480	1.850	5.184
3-5/16	Z-4053L	5.000	5.000	7.480	1.850	5.184
3-3/8	Z-4054L	5.000	5.000	7.480	1.930	5.184
3-7/16	Z-4055L	5.315	5.000	7.480	1.930	5.184
3-1/2	Z-4056L	5.315	5.000	7.480	1.930	5.184
3-9/16	Z-4057L	5.315	5.000	7.480	1.930	5.184
3-5/8	Z-4058L	5.315	5.000	7.480	1.930	5.184
3-11/16	Z-4059L	5.315	5.000	7.480	1.930	5.184
3-3/4	Z-4060L	5.512	5.000	7.480	1.930	5.184
3-13/16	Z-4061L	5.709	5.000	7.720	2.125	5.420
3-7/8	Z-4062L	5.709	5.000	7.720	2.125	5.420
3-15/16	Z-4063L	5.709	5.000	7.720	2.125	5.420
4	Z-4064L	5.906	5.000	7.720	2.125	5.420
4-1/16	Z-4065L	5.906	5.000	7.720	2.125	5.420
4-1/8	Z-4066L	6.102	5.000	7.720	2.125	5.420
4-3/16	Z-4067L	6.102	5.000	8.070	2.440	5.775
4-1/4	Z-4068L	6.102	5.000	8.070	2.440	5.775
4-5/16	Z-4069L	6.299	5.000	8.070	2.44	5.775
4-3/8	Z-4070L	6.299	5.000	8.070	2.44	5.775
4-7/16	Z-4071L	6.496	5.000	8.070	2.44	5.775
4-1/2	Z-4072L	6.496	5.000	8.070	2.44	5.775
4-5/8	Z-4074L	6.693	5.000	8.380	2.64	6.090
4-3/4	Z-4076L	6.693	5.000	8.380	2.64	6.090
4-7/8	Z-4078L	6.693	5.000	8.380	2.64	6.090
5	Z-4080L	7.087	5.000	8.700	2.83	6.405
5-1/8	Z-4082L	7.087	5.000	9.000	2.99	6.719
5-3/16	Z-4083L	7.087	5.000	9.000	2.99	6.719

DEEP FRACTIONAL SIZES

SIZE	PART#	D1	D2	L	T	C
5-1/4	Z-4084L	7.480	5.000	9.000	2.99	6.719
5-3/8	Z-4086L	7.480	5.000	9.000	2.99	6.719
5-1/2	Z-4088L	7.480	5.000	9.120	3.110	7.074
5-5/8	Z-4090L	7.874	5.906	9.360	3.270	7.074
5-3/4	Z-4092L	7.874	5.906	9.360	3.270	7.074
5-7/8	Z-4094L	8.268	5.906	9.670	3.460	7.389
6	Z-4096L	8.268	5.906	9.670	3.460	7.389
6-1/8	Z-4098L	8.268	5.906	9.670	3.460	7.389
6-1/4	Z-4100L	8.661	5.906	9.820	3.580	7.546
6-3/8	Z-4102L	8.661	5.906	9.820	3.580	7.546
6-1/2	Z-4104L	9.055	6.890	10.140	3.700	8.019
6-5/8	Z-4106L	9.055	6.890	10.140	3.700	8.019
6-3/4	Z-4108L	9.055	6.890	10.300	3.900	8.019
6-7/8	Z-4110L	9.449	6.890	10.300	3.900	8.019
7	Z-4112L	9.449	6.890	10.600	4.090	8.334
7-1/8	Z-4114L	9.843	6.890	10.600	4.090	8.334
7-1/4	Z-4116L	9.843	6.890	10.600	4.090	8.334
7-3/8	Z-4118L	9.843	6.890	10.760	4.210	8.491
7-1/2	Z-4120L	10.236	6.890	10.760	4.210	8.491
7-5/8	Z-4122L	10.236	6.890	10.920	4.290	8.649
7-3/4	Z-4124L	10.630	6.890	10.070	4.410	8.806
7-13/16	Z-4125L	10.630	6.890	10.070	4.410	8.806
7-7/8	Z-4126L	10.630	6.890	10.070	4.410	8.806
8	Z-4128L	10.630	6.890	11.310	4.530	9.318
8-1/8	Z-4130L	11.024	6.890	11.310	4.530	9.318
8-1/4	Z-4132L	11.024	6.890	11.310	4.530	9.318
8-3/8	Z-4134L	11.417	6.890	11.580	4.720	9.318
8-1/2	Z-4136L	11.417	6.890	12.320	4.800	10.066
8-3/4	Z-4140L	11.811	6.890	12.320	4.880	10.066
8-7/8	Z-4142L	11.811	6.890	12.320	4.960	10.066
9	Z-4144L	12.205	6.890	12.320	5.040	10.066
9-1/8	Z-4146L	12.205	6.890	12.320	5.160	10.066
9-1/4	Z-4148L	12.205	6.890	12.980	5.240	11.798

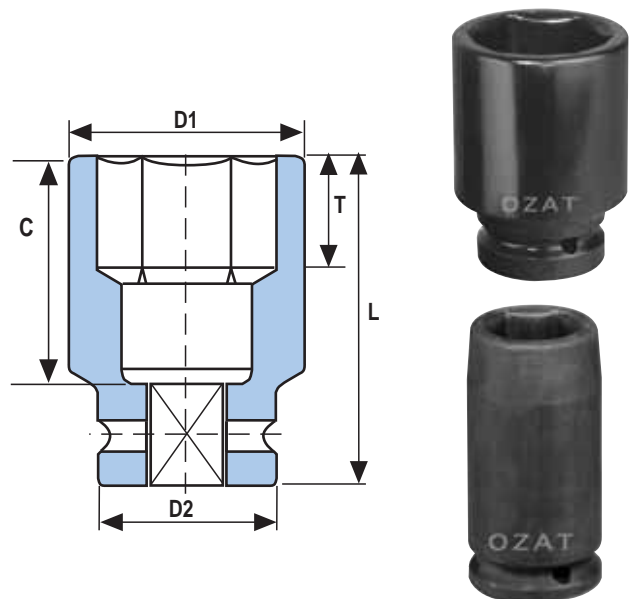

Table continued next column

2½" SQUARE DRIVE

SIX POINT IMPACT SOCKETS

STANDARD METRIC SIZES

SIZE	PART#	D1	D2	L	T	C
41	Z-40M41	104	127	115	21.5	60
42	Z-40M42	104	127	115	21.5	60
43	Z-40M43	104	127	115	25	60
44	Z-40M44	104	127	115	21.5	60
45	Z-40M45	104	127	115	21.5	60
46	Z-40M46	104	127	115	25.5	60
47	Z-40M47	104	127	115	23.5	60
48	Z-40M48	104	127	115	23.5	60
49	Z-40M49	104	127	115	27	60
50	Z-40M50	104	127	115	23.5	60
51	Z-40M51	104	127	115	27	60
52	Z-40M52	104	127	115	27	60
54	Z-40M54	104	127	115	30	60
55	Z-40M55	104	127	115	27	60
56	Z-40M56	104	127	115	28	60
57	Z-40M57	104	127	115	32.5	60
58	Z-40M58	104	127	115	28	60
59	Z-40M59	104	127	115	33	60
60	Z-40M60	104	127	115	28	60
61	Z-40M61	104	127	115	28	60
62	Z-40M62	104	127	115	35	60
65	Z-40M65	104	127	115	35	60
67	Z-40M67	104	127	115	38	60
70	Z-40M70	104	127	115	38	60
73	Z-40M73	115	127	125	41	70
75	Z-40M75	115	127	125	41	70
76	Z-40M76	115	127	125	44	70
80	Z-40M80	115	127	125	37	70
85	Z-40M85	127	127	130	40	75
86	Z-40M86	127	127	130	49	75
90	Z-40M90	135	127	132	43	77
95	Z-40M95	140	127	132	49	77
100	Z-40M100	145	127	141	54	86
105	Z-40M105	150	127	141	54	86
110	Z-40M110	160	127	150	62	95
115	Z-40M115	165	127	158	57	103
120	Z-40M120	170	127	158	67	103
125	Z-40M125	170	127	158	67	103
130	Z-40M130	180	127	174	76	119
135	Z-40M135	190	127	174	76	119
140	Z-40M140	190	127	176	79	121
145	Z-40M145	200	150	182	83	127
150	Z-40M150	210	150	190	88	135
155	Z-40M155	210	150	190	88	135
160	Z-40M160	220	150	194	91	139
165	Z-40M165	230	175	201	94	146
170	Z-40M170	230	175	201	94	146
175	Z-40M175	240	175	208	99	153
180	Z-40M180	240	175	214	104	159
185	Z-40M185	250	175	214	104	159
190	Z-40M190	260	175	218	107	163
195	Z-40M195	260	175	222	109	167
200	Z-40M200	270	175	226	112	171
210	Z-40M210	280	175	232	115	177
215	Z-40M215	290	175	239	120	184
225	Z-40M225	300	175	258	126	203
235	Z-40M235	310	175	275	131	220

DEEP METRIC SIZES

SIZE	PART#	D1	D2	L	T	C
41	Z-40M41L	104	127	192	21.5	132
42	Z-40M42L	104	127	192	21.5	132
43	Z-40M43L	104	127	192	25	132
44	Z-40M44L	104	127	192	21.5	132
45	Z-40M45L	104	127	192	21.5	132
46	Z-40M46L	104	127	192	25.5	132
47	Z-40M47L	104	127	192	23.5	132
48	Z-40M48L	104	127	192	23.5	132
49	Z-40M49L	104	127	192	27	132
50	Z-40M50L	104	127	192	23.5	132
51	Z-40M51L	104	127	192	27	132
52	Z-40M52L	104	127	192	27	132
54	Z-40M54L	104	127	192	30	132
55	Z-40M55L	104	127	192	27	132
56	Z-40M56L	104	127	192	28	132
57	Z-40M57L	104	127	192	32.5	132
58	Z-40M58L	104	127	192	28	132
59	Z-40M59L	104	127	192	33	132
60	Z-40M60L	104	127	192	28	132
61	Z-40M61L	104	127	192	28	132
62	Z-40M62L	104	127	192	35	132
65	Z-40M65L	104	127	192	35	132
67	Z-40M67L	104	127	192	38	132
70	Z-40M70L	104	127	192	38	132
73	Z-40M73L	115	127	192	41	132
75	Z-40M75L	115	127	192	41	132
76	Z-40M76L	115	127	192	44	132
80	Z-40M80L	115	127	192	37	132
85	Z-40M85L	127	127	192	40	132
86	Z-40M86L	127	127	192	49	132
90	Z-40M90L	135	127	192	43	132
95	Z-40M95L	140	127	192	49	132
100	Z-40M100L	145	127	198	54	138
105	Z-40M105L	150	127	198	54	138
110	Z-40M110L	160	127	207	62	147
115	Z-40M115L	165	127	207	57	147
120	Z-40M120L	170	127	215	67	155
125	Z-40M125L	170	127	215	67	155
130	Z-40M130L	180	127	223	76	163
135	Z-40M135L	190	127	231	76	151
140	Z-40M140L	190	127	234	79	174
145	Z-40M145L	200	150	240	83	180
150	Z-40M150L	210	150	248	88	188
155	Z-40M155L	210	150	248	88	188
160	Z-40M160L	220	150	252	91	192
165	Z-40M165L	230	175	260	94	200
170	Z-40M170L	230	175	260	94	200
175	Z-40M175L	240	175	264	99	204
180	Z-40M180L	240	175	272	104	212
185	Z-40M185L	250	175	272	104	212
190	Z-40M190L	260	175	276	107	216
195	Z-40M195L	260	175	280	109	220
200	Z-40M200L	270	175	284	112	224
210	Z-40M210L	280	175	290	115	230
215	Z-40M215L	290	175	316	120	256
225	Z-40M225L	300	175	316	126	256
235	Z-40M235L	310	175	333	131	273

2 1/2" SQUARE DRIVE

ACCESSORIES

ADAPTERS

PART#	FEMALE	MALE	L
A4024	2-1/2	1-1/2	5.380
A4056	2-1/2	3-1/2	5.538

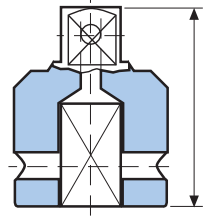

No one offers a broader line of 2-1/2" drive sockets than ATP for the heaviest bolting applications in construction, plant maintenance, power generation, shipbuilding, and refining.

OZAT sockets prove their value. They are guaranteed for hydraulic bolting jobs as well as for large impact wrenches, OZAT has a socket to exactly match your application. If not available from our standard product range, we'll custom design one for you. (See Page 80.)

DOUBLE ENDED FEMALE ADAPTERS

PART#	D1	D2	L
AN4024	2-1/2	1-1/2	4.53
AN4040	2-1/2	2-1/2	4.61
AN5640	2-1/2	3-1/2	6.34

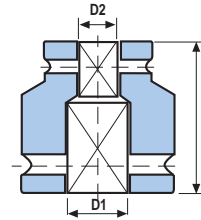

DOUBLE ENDED MALE ADAPTERS

PART#	D1	L
Z4005	3.31	5
Z4006	3.31	6
Z4008	3.31	8
Z4010	3.31	10
Z4015	3.31	15
Z4020	3.31	20
Z4026	3.31	26

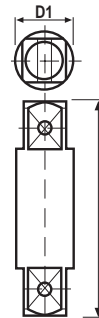

UNIVERSAL JOINT

SIZE	PART#
2-1/2	U4040



RETAINING PINS AND RINGS

SQUARE DRIVE	THROUGH HEX SIZE	PIN #	RING#	d	L	D
2-1/2	5-1/2 - 140mm	P40127	R40127	.312	4.290	4.446
2-1/2	6-3/8 - 160mm	P40150	R40150	.312	5.187	5.309
2-1/2	Above 6-3/8	P40175	R40175	.312	6.162	6.318

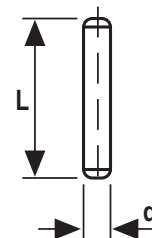
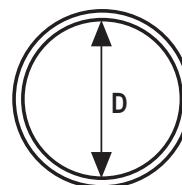

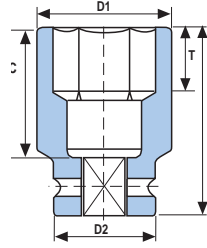
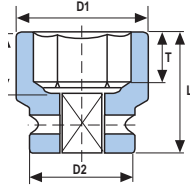

STANDARD FRACTIONAL SIZES

SIZE	PART#	D1	D2	L	T	C
3-7/8	Z-5662	6.890	6.890	6.435	2.125	3.371
3-15/16	Z-5663	6.890	6.890	6.435	2.125	3.725
4	Z-5664	6.890	6.890	6.435	2.125	3.725
4-1/16	Z-5665	6.890	6.890	6.435	2.125	3.725
4-1/8	Z-5666	6.890	6.890	6.435	2.125	3.725
4-3/16	Z-5667	6.890	6.890	6.786	2.440	3.725
4-1/4	Z-5668	6.890	6.890	6.786	2.440	3.725
4-5/16	Z-5669	6.890	6.890	6.786	2.440	4.040
4-3/8	Z-5670	6.890	6.890	6.786	2.440	4.040
4-7/16	Z-5671	6.890	6.890	6.786	2.440	4.040
4-1/2	Z-5672	6.890	6.890	6.786	2.440	4.040
4-5/8	Z-5674	6.890	6.890	7.100	2.640	4.040
4-3/4	Z-5676	6.890	6.890	7.100	2.640	4.355
4-7/8	Z-5678	6.890	6.890	7.100	2.640	4.355
5	Z-5680	7.480	6.890	7.722	2.830	4.355
5-1/8	Z-5682	7.480	6.890	7.722	3.000	4.355
5-3/16	Z-5683	7.480	6.890	7.722	3.000	4.670
5-1/4	Z-5684	7.480	6.890	7.722	3.000	4.670
5-3/8	Z-5686	7.874	6.890	7.722	3.000	4.670
5-1/2	Z-5688	7.874	6.890	8.000	3.110	5.300
5-5/8	Z-5690	8.268	6.890	8.270	3.270	5.300
5-3/4	Z-5692	8.268	6.890	8.270	3.270	5.300
5-7/8	Z-5694	8.268	6.890	8.270	3.460	5.300
6	Z-5696	8.661	6.890	8.350	3.460	5.300
6-1/8	Z-5698	8.661	6.890	8.350	3.460	5.300
6-1/4	Z-56100	9.055	6.890	8.500	3.580	5.458
6-3/8	Z-56102	9.055	6.890	8.500	3.580	5.458
6-1/2	Z-56104	9.055	6.890	8.970	3.700	5.930
6-5/8	Z-56106	9.449	6.890	8.970	3.700	5.930
6-3/4	Z-56108	9.449	6.890	8.970	3.900	5.930
6-7/8	Z-56110	9.843	6.890	8.970	3.900	5.930
7	Z-56112	9.843	6.890	9.250	4.090	6.206
7-1/8	Z-56114	9.843	6.890	9.250	4.090	6.206
7-1/4	Z-56116	10.236	6.890	9.250	4.090	6.206
7-3/8	Z-56118	10.236	6.890	9.438	4.210	6.363
7-1/2	Z-56120	10.630	6.890	9.438	4.210	6.363
7-5/8	Z-56122	10.630	6.890	9.600	4.290	6.521
7-3/4	Z-56124	10.630	6.890	9.710	4.410	6.678
7-13/16	Z-56125	11.024	6.890	9.710	4.410	6.678
7-7/8	Z-56126	11.024	6.890	9.710	4.410	6.678
8	Z-56128	11.024	6.890	10.000	4.530	7.229
8-1/8	Z-56130	11.417	6.890	10.000	4.530	7.229
8-1/4	Z-56132	11.417	6.890	10.000	4.530	7.229
8-3/8	Z-56134	11.417	6.890	10.250	4.720	7.229
8-1/2	Z-56136	11.811	6.890	10.410	4.800	7.859
8-3/4	Z-56140	12.205	6.890	10.530	4.880	7.859
8-7/8	Z-56142	12.205	6.890	10.640	4.960	7.859
9	Z-56144	12.205	6.890	10.760	5.040	7.859
9-1/8	Z-56146	12.598	6.890	10.880	5.160	7.859
9-1/4	Z-56148	12.598	6.890	11.110	5.240	9.198

DEEP FRACTIONAL SIZES

SIZE	PART#	D1	D2	L	T	C
3-7/8	Z-5662L	6.890	6.890	10.800	2.125	7.781
3-15/16	Z-5663L	6.890	6.890	10.800	2.125	7.781
4	Z-5664L	6.890	6.890	10.800	2.125	7.781
4-1/16	Z-5665L	6.890	6.890	10.800	2.125	7.781
4-1/8	Z-5666L	6.890	6.890	10.800	2.125	7.781
4-3/16	Z-5667L	6.890	6.890	10.800	2.440	7.781
4-1/4	Z-5668L	6.890	6.890	10.800	2.440	7.781
4-5/16	Z-5669L	6.890	6.890	10.800	2.440	7.781
4-3/8	Z-5670L	6.890	6.890	10.800	2.440	7.781
4-7/16	Z-5671L	6.890	6.890	10.800	2.440	7.781
4-1/2	Z-5672L	6.890	6.890	10.800	2.440	7.781
4-5/8	Z-5674L	6.890	6.890	10.800	2.640	7.781
4-3/4	Z-5676L	6.890	6.890	10.800	2.640	7.781
4-7/8	Z-5678L	6.890	6.890	10.800	2.640	7.781
5	Z-5680L	7.480	6.890	10.800	2.830	7.781
5-1/8	Z-5682L	7.480	6.890	10.920	3.000	7.781
5-3/16	Z-5683L	7.480	6.890	10.920	3.000	7.899
5-1/4	Z-5684L	7.480	6.890	10.920	3.000	7.899
5-3/8	Z-5686L	7.874	6.890	10.920	3.000	7.899
5-1/2	Z-5688L	7.874	6.890	11.230	3.110	8.568
5-5/8	Z-5690L	8.268	6.890	11.500	3.270	8.568
5-3/4	Z-5692L	8.268	6.890	11.500	3.270	8.568
5-7/8	Z-5694L	8.268	6.890	11.500	3.460	8.568
6	Z-5696L	8.661	6.890	11.580	3.460	8.568
6-1/8	Z-5698L	8.661	6.890	11.580	3.460	8.568
6-1/4	Z-56100L	9.055	6.890	11.740	3.580	8.725
6-3/8	Z-56102L	9.055	6.890	11.740	3.580	8.725
6-1/2	Z-56104L	9.055	6.890	12.220	3.700	9.198
6-5/8	Z-56106L	9.449	6.890	12.220	3.700	9.198
6-3/4	Z-56108L	9.449	6.890	12.220	3.900	9.198
6-7/8	Z-56110L	9.843	6.890	12.220	3.900	9.198
7	Z-56112L	9.843	6.890	12.480	4.090	9.473
7-1/8	Z-56114L	9.843	6.890	12.480	4.090	9.473
7-1/4	Z-56116L	10.236	6.890	12.480	4.090	9.473
7-3/8	Z-56118L	10.236	6.890	12.630	4.210	9.631
7-1/2	Z-56120L	10.630	6.890	12.630	4.210	9.631
7-5/8	Z-56122L	10.630	6.890	12.800	4.290	9.788
7-3/4	Z-56124L	10.630	6.890	12.950	4.410	9.946
7-13/16	Z-56125L	11.024	6.890	12.950	4.410	9.946
7-7/8	Z-56126L	11.024	6.890	12.950	4.410	9.946
8	Z-56128L	11.024	6.890	13.220	4.530	10.497
8-1/8	Z-56130L	11.417	6.890	13.220	4.530	10.497
8-1/4	Z-56132L	11.417	6.890	13.220	4.530	10.497
8-3/8	Z-56134L	11.417	6.890	13.500	4.720	10.497
8-1/2	Z-56136L	11.811	6.890	13.650	4.800	11.127
8-3/4	Z-56140L	12.205	6.890	13.800	4.880	11.127
8-7/8	Z-56142L	12.205	6.890	13.920	4.960	11.127
9	Z-56144L	12.205	6.890	14.000	5.040	11.127
9-1/8	Z-56146L	12.598	6.890	14.110	5.160	11.127
9-1/4	Z-56148L	12.598	6.890	14.430	5.240	12.426

STANDARD METRIC SIZES

SIZE	PART#	D1	D2	L	T	C
100	Z-56M100	175	175	165	54	95
105	Z-56M105	175	175	165	54	94
110	Z-56M110	175	175	174	62	103
115	Z-56M115	175	175	174	57	103
120	Z-56M120	175	175	182	67	111
125	Z-56M125	175	175	182	67	111
130	Z-56M130	190	175	198	76	111
135	Z-56M135	190	175	198	76	119
140	Z-56M140	200	175	205	79	135
145	Z-56M145	210	175	212	83	135
150	Z-56M150	210	175	212	88	135
155	Z-56M155	220	175	214	88	135
160	Z-56M160	220	175	218	91	139
165	Z-56M165	230	175	230	94	151
170	Z-56M170	240	175	230	94	151
175	Z-56M175	250	175	230	99	151
180	Z-56M180	250	175	237	104	158
185	Z-56M185	260	175	237	104	158
190	Z-56M190	260	175	242	107	162
195	Z-56M195	270	175	246	109	166
200	Z-56M200	280	175	249	112	170
210	Z-56M210	290	175	256	115	184
215	Z-56M215	300	175	263	120	220
225	Z-56M225	310	175	273	126	200
230	Z-56M230	310	175	276	128	200
235	Z-56M235	320	175	279	131	200

DEEP METRIC SIZES

SIZE	PART#	D1	D2	L	T	C
100	Z-56M100L	175	175	277	54	198
105	Z-56M105L	175	175	277	54	198
110	Z-56M110L	175	175	277	62	198
115	Z-56M115L	175	175	277	57	198
120	Z-56M120L	175	175	277	67	198
125	Z-56M125L	175	175	277	67	198
130	Z-56M130L	190	175	280	76	198
135	Z-56M135L	190	175	280	76	201
140	Z-56M140L	200	175	288	79	218
145	Z-56M145L	210	175	295	83	218
150	Z-56M150L	210	175	295	88	218
155	Z-56M155L	220	175	297	88	218
160	Z-56M160L	220	175	301	91	222
165	Z-56M165L	230	175	313	94	234
170	Z-56M170L	240	175	313	94	234
175	Z-56M175L	250	175	313	99	234
180	Z-56M180L	250	175	320	104	241
185	Z-56M185L	260	175	320	104	241
190	Z-56M190L	260	175	324	107	245
195	Z-56M195L	270	175	328	109	249
200	Z-56M200L	280	175	332	112	253
210	Z-56M210L	290	175	339	115	267
215	Z-56M215L	300	175	346	120	283
225	Z-56M225L	310	175	357	126	283
230	Z-56M230L	310	175	359	128	283
235	Z-56M235L	320	175	362	131	283

ACCESSORIES

ADAPTERS

PART#	FEMALE	MALE	L
A5640	3-1/2	2-1/2	7.137

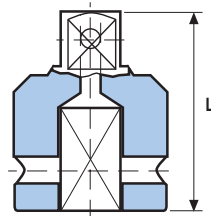

DOUBLE ENDED FEMALE ADAPTERS

PART#	D1	L
AN5640	3-1/2	2-1/2
AN5656	3-1/2	3-1/2

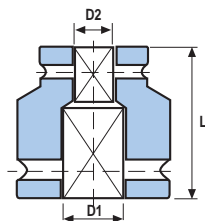

DOUBLE ENDED MALE EXTENSIONS

PART#	D1	L
Z5610	4.685	10
Z5620	4.685	20
Z5640	4.685	40

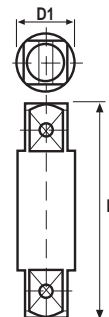

RETAINING PINS AND RINGS

SQUARE DRIVE	THROUGH HEX SIZE	PIN #	RING#	d	L	D
3-1/2	ALL	P56175	R56175	.390	6.24	6.24

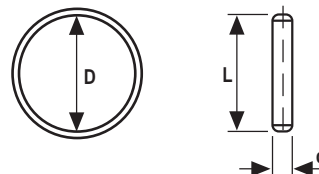

#5 SPLINE DRIVE

SIX POINT IMPACT SOCKETS

STANDARD FRACTIONAL SIZES

SIZE	PART#	D1	D2	L	T	C
3/4	Z-9512	1.890	2.362	2.730	0.374	1.006
13/16	Z-9513	1.890	2.362	2.730	0.435	1.006
7/8	Z-9514	1.890	2.362	2.730	0.512	1.006
15/16	Z-9515	1.890	2.362	2.730	0.512	1.006
1	Z-9516	1.929	2.362	2.730	0.512	1.006
1-1/16	Z-9517	2.008	2.362	2.730	0.512	1.006
1-1/8	Z-9518	2.008	2.362	2.730	0.650	1.006
1-3/16	Z-9519	2.126	2.362	2.730	0.650	1.006
1-1/4	Z-9520	2.362	2.362	2.925	0.669	1.203
1-5/16	Z-9521	2.362	2.362	3.000	0.748	1.281
1-3/8	Z-9522	2.362	2.362	3.000	0.748	1.281
1-7/16	Z-9523	2.480	2.362	3.000	0.748	1.281
1-1/2	Z-9524	2.480	2.362	3.125	0.866	1.400
1-9/16	Z-9525	2.638	2.362	3.125	0.866	1.400
1-5/8	Z-9526	2.638	2.362	3.125	0.866	1.400
1-11/16	Z-9527	2.638	2.362	3.275	0.984	1.557
1-3/4	Z-9528	2.874	2.362	3.275	1.000	1.557
1-13/16	Z-9529	2.874	2.362	3.275	1.000	1.577
1-7/8	Z-9530	2.874	2.362	3.432	1.063	1.715
1-15/16	Z-9531	2.874	2.362	3.432	1.063	1.715
2	Z-9532	3.228	2.362	3.432	1.063	1.715
2-1/16	Z-9533	3.228	3.386	3.625	1.181	1.911
2-1/8	Z-9534	3.228	3.386	3.625	1.181	1.911
2-3/16	Z-9535	3.228	3.386	3.740	1.260	2.030
2-1/4	Z-9536	3.465	3.386	3.740	1.299	2.030
2-5/16	Z-9537	3.465	3.386	3.740	1.299	2.030
2-3/8	Z-9538	3.465	3.386	3.822	1.378	2.108
2-7/16	Z-9539	3.465	3.386	3.900	1.378	2.108
2-1/2	Z-9540	3.937	3.386	3.900	1.378	2.108
2-9/16	Z-9541	3.937	3.386	3.900	1.378	2.108
2-5/8	Z-9542	3.937	3.386	3.978	1.496	2.266
2-11/16	Z-9543	3.937	3.386	3.978	1.496	2.266
2-3/4	Z-9544	3.937	3.386	3.978	1.496	2.266
2-13/16	Z-9545	4.134	3.386	4.210	1.575	2.502
2-7/8	Z-9546	4.134	3.386	4.210	1.614	2.502
2-15/16	Z-9547	4.134	3.386	4.210	1.614	2.502
3	Z-9548	4.291	3.386	4.446	1.732	2.738
3-1/16	Z-9549	4.291	3.386	4.446	1.732	2.738
3-1/8	Z-9550	4.291	3.386	4.446	1.732	2.738
3-1/4	Z-9552	5.062	3.386	4.909	2.106	2.781
3-5/16	Z-9553	5.062	3.386	4.909	2.106	2.781
3-3/8	Z-9554	5.062	3.386	4.909	2.106	2.781
3-1/2	Z-9556	5.129	3.386	4.909	2.106	2.781
3-5/8	Z-9558	5.256	3.386	4.909	2.106	2.781
3-3/4	Z-9560	5.309	3.386	4.909	2.106	2.781
3-7/8	Z-9562	5.442	3.386	4.909	2.106	2.781
4	Z-9564	5.511	3.386	4.909	2.106	2.781

DEEP FRACTIONAL SIZES

SIZE	PART#	D1	D2	L	T	C
3/4	Z-9512L	1.890	2.362	6.240	0.374	4.549
13/16	Z-9513L	1.890	2.362	6.240	0.435	4.549
7/8	Z-9514L	1.890	2.362	6.240	0.512	4.549
15/16	Z-9515L	1.890	2.362	6.240	0.512	4.549
1	Z-9516L	1.929	2.362	6.240	0.512	4.549
1-1/16	Z-9517L	2.008	2.362	6.240	0.512	4.549
1-1/8	Z-9518L	2.008	2.362	6.240	0.650	4.549
1-3/16	Z-9519L	2.126	2.362	6.240	0.650	4.549
1-1/4	Z-9520L	2.362	2.362	6.240	0.669	4.549
1-5/16	Z-9521L	2.362	2.362	6.240	0.748	4.549
1-3/8	Z-9522L	2.362	2.362	6.240	0.748	4.549
1-7/16	Z-9523L	2.480	2.362	6.240	0.748	4.549
1-1/2	Z-9524L	2.480	2.362	6.240	0.866	4.549
1-9/16	Z-9525L	2.638	2.362	6.240	0.866	4.549
1-5/8	Z-9526L	2.638	2.362	6.240	0.866	4.549
1-11/16	Z-9527L	2.638	2.362	6.240	0.984	4.549
1-3/4	Z-9528L	2.874	2.362	6.240	1.000	4.549
1-13/16	Z-9529L	2.874	2.362	6.240	1.000	4.549
1-7/8	Z-9530L	2.874	2.362	6.240	1.063	4.549
1-15/16	Z-9531L	2.874	2.362	6.240	1.063	4.549
2	Z-9532L	3.228	2.362	6.240	1.063	4.549
2-1/16	Z-9533L	3.228	3.386	6.240	1.181	4.549
2-1/8	Z-9534L	3.228	3.386	6.240	1.181	4.549
2-3/16	Z-9535L	3.228	3.386	6.240	1.260	4.549
2-1/4	Z-9536L	3.465	3.386	6.240	1.299	4.549
2-5/16	Z-9537L	3.465	3.386	6.240	1.299	4.549
2-3/8	Z-9538L	3.465	3.386	6.240	1.373	4.549
2-7/16	Z-9539L	3.465	3.386	6.240	1.378	4.549
2-1/2	Z-9540L	3.937	3.386	6.240	1.378	4.549
2-9/16	Z-9541L	3.937	3.386	6.240	1.378	4.549
2-5/8	Z-9542L	3.937	3.386	6.240	1.496	4.549
2-11/16	Z-9543L	3.937	3.386	6.240	1.496	4.549
2-3/4	Z-9544L	3.937	3.386	6.240	1.496	4.549
2-13/16	Z-9545L	4.134	3.386	6.240	1.575	4.549
2-7/8	Z-9546L	4.134	3.386	6.240	1.614	4.549
2-15/16	Z-9547L	4.134	3.386	6.240	1.614	4.549
3	Z-9548L	4.291	3.386	6.240	1.732	4.628
3-1/16	Z-9549L	4.291	3.386	6.310	1.732	4.628
3-1/8	Z-9550L	4.291	3.386	6.310	1.732	4.628

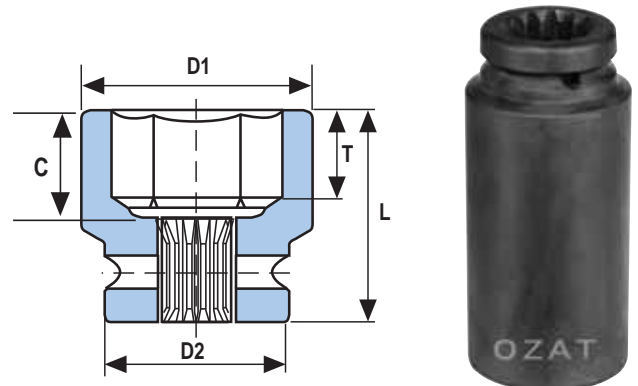

#5 SPLINE DRIVE

SIX POINT IMPACT SOCKETS

STANDARD METRIC SIZES

SIZE	PART#	D1	D2	L	T	C
19	Z-95M19	48	60	70	0.374	26
20	Z-95M20	48	60	70	0.394	26
21	Z-95M21	48	60	70	0.394	26
22	Z-95M22	48	60	70	0.394	26
23	Z-95M23	48	60	70	0.472	26
24	Z-95M24	49	60	70	0.472	26
25	Z-95M25	49	60	70	0.512	26
26	Z-95M26	51	60	70	0.512	26
27	Z-95M27	51	60	70	0.512	26
28	Z-95M28	51	60	70	0.551	26
29	Z-95M29	54	60	70	0.551	26
30	Z-95M30	54	60	70	0.650	26
31	Z-95M31	60	60	75	0.650	31
32	Z-95M32	60	60	75	0.650	31
33	Z-95M33	60	60	75	0.669	31
34	Z-95M34	60	60	77	0.669	33
35	Z-95M35	60	60	77	0.748	33
36	Z-95M36	63	60	77	0.748	33
37	Z-95M37	63	60	77	0.748	33
38	Z-95M38	63	60	80	0.866	36
39	Z-95M39	67	60	80	0.866	36
40	Z-95M40	67	60	80	0.866	36
41	Z-95M41	67	60	80	0.866	36
42	Z-95M42	67	60	80	0.846	36
43	Z-95M43	67	60	84	0.984	40
44	Z-95M44	73	60	84	0.846	40
45	Z-95M45	73	60	84	0.846	40
46	Z-95M46	73	60	84	1.004	40
47	Z-95M47	73	60	84	0.925	40
48	Z-95M48	73	60	88	0.925	44
49	Z-95M49	73	60	88	1.063	44
50	Z-95M50	82	60	88	0.925	44
51	Z-95M51	82	60	88	1.063	44
52	Z-95M52	82	60	88	1.063	44
54	Z-95M54	82	60	93	1.181	49
55	Z-95M55	82	60	93	1.063	49
56	Z-95M56	88	86	96	1.102	52
57	Z-95M57	88	76	96	1.299	52
58	Z-95M58	88	86	96	1.102	52
59	Z-95M59	88	86	96	1.299	52
60	Z-95M60	88	86	96	1.102	52
61	Z-95M61	88	86	98	1.102	54
62	Z-95M62	88	86	100	1.378	56
65	Z-95M65	100	86	100	1.378	56
67	Z-95M67	100	86	102	1.496	58
70	Z-95M70	100	86	102	1.496	58
73	Z-95M73	105	86	108	1.614	64
75	Z-95M75	105	86	108	1.614	64
76	Z-95M76	109	86	114	1.732	70
80	Z-95M80	115	86	114	1.457	70

DEEP METRIC SIZES

SIZE	PART#	D1	D2	L	T	C
19	Z-95M19L	48	60	160	0.374	116
20	Z-95M20L	48	60	160	0.394	116
21	Z-95M21L	48	60	160	0.394	116
22	Z-95M22L	48	60	160	0.394	116
23	Z-95M23L	48	60	160	0.472	116
24	Z-95M24L	49	60	160	0.472	116
25	Z-95M25L	49	60	160	0.512	116
26	Z-95M26L	51	60	160	0.512	116
27	Z-95M27L	51	60	160	0.512	116
28	Z-95M28L	51	60	160	0.551	116
29	Z-95M29L	54	60	160	0.551	116
30	Z-95M30L	54	60	160	0.650	116
31	Z-95M31L	60	60	160	0.650	116
32	Z-95M32L	60	60	160	0.650	116
33	Z-95M33L	60	60	160	0.669	116
34	Z-95M34L	60	60	160	0.669	116
35	Z-95M35L	60	60	160	0.748	116
36	Z-95M36L	63	60	160	0.748	116
37	Z-95M37L	63	60	160	0.748	116
38	Z-95M38L	63	60	160	0.866	116
39	Z-95M39L	67	60	160	0.866	116
40	Z-95M40L	67	60	160	0.866	116
41	Z-95M41L	67	60	160	0.866	116
42	Z-95M42L	67	60	160	0.846	116
43	Z-95M43L	67	60	160	0.984	116
44	Z-95M44L	73	60	160	0.846	116
45	Z-95M45L	73	60	160	0.846	116
46	Z-95M46L	73	60	160	1.004	116
47	Z-95M47L	73	60	160	0.925	116
48	Z-95M48L	73	60	160	0.925	116
49	Z-95M49L	73	60	160	1.063	116
50	Z-95M50L	82	60	160	0.925	116
51	Z-95M51L	82	60	160	1.063	116
52	Z-95M52L	82	60	160	1.063	116
54	Z-95M54L	82	60	160	1.181	116
55	Z-95M55L	82	60	160	1.063	116
56	Z-95M56L	88	86	160	1.102	116
57	Z-95M57L	88	76	160	1.299	116
58	Z-95M58L	88	86	160	1.102	116
59	Z-95M59L	88	86	160	1.299	116
60	Z-95M60L	88	86	160	1.102	116
61	Z-95M61L	88	86	160	1.102	116
62	Z-95M62L	88	86	160	1.378	116
65	Z-95M65L	100	86	160	1.378	116
67	Z-95M67L	100	86	160	1.496	116
70	Z-95M70L	100	86	160	1.496	116
73	Z-95M73L	105	86	160	1.614	116
75	Z-95M75L	105	86	162	1.614	116
76	Z-95M76L	109	86	162	1.732	118
80	Z-95M80L	115	86	162	1.457	118

BUDD WHEEL SOCKETS

SIZE	PART#	D1	D2	L	T
13/16 X 1-1/2	Z-9524BS	2.48	2.36	4.133	0.571
13/16	Z-9513B	2.008	2.36	2.756	0.472

#4 SPLINE DRIVE

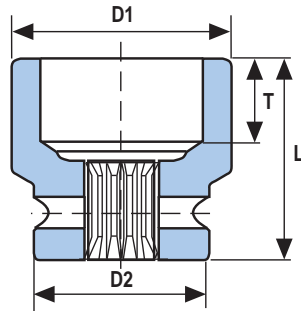

UNIVERSAL JOINT

SIZE	PART#
#4 Spline Drive	U9494

IMPACT SOCKETS

6 POINT IMPACT SOCKETS REGULAR LENGTH

NOMINAL OPENING			D1	D2	L	
mm	A/F Inch	CATALOG No.	mm	mm	mm	t min
17	1-1/16"	Z-9417M27	46.0	52	59	13.0
	1-1/8"	Z-9418	48	52	65	16.5
30	1 3/16"	Z-9419M30	50	52	65	16.5
	1-1/4"	Z-9420	52	52	65	17
35	1-5/16"	Z-9421	52	52	68	19
	1 3/8"	Z-9422M35	52	52	68	19
38	1-7/16"	Z-9423	52	52	68	19
	1-1/2"	Z-9424M38	52	52	73	22
41	1-9/16"	Z-9425	57	52	73	22
	1-5/8"	Z-9426M41	57	52	73	22
	1-11/16"	Z-9427	57	52	73	22
	1-3/4"	Z-9428	63	52	78	25.5
	1-13/16"	Z-9429	67	52	78	25.5
	1-7/8"	Z-9430	67	52	78	27
	1-15/16"	Z-9431	70	52	81	27
	2"	Z-9432	73	52	81	27
	2-1/16"	Z-9433	73	52	85	30
	2-1/8"	Z-9434	78	52	88	32
	2-3/16"	Z-9435	78	52	88	23
	2-1/4"	Z-9436	78	52	88	23

ACCESSORIES FOR #5 SPLINE DRIVE

ADAPTERS

PART#	FEMALE	MALE
A9516	#5	1"
A9524	#5	1-1/2"
A2495	1-1/2"	#5

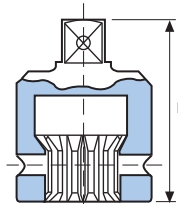

EXTENSIONS

PART#	L
E9508	8
E9515	15

UNIVERSAL JOINT

SIZE	PART#
#5 Spline Drive	U9595



UNIVERSAL JOINT REPAIR KITS

PART #	DESCRIPTION
95UK1	Retainer Kit Contents: Hex Plunger, Lock Button, Inner & Outer Springs
95UK2	Pin Kit Contents: Drive Pin, Trunions, Spiral Pins
95UK3	Retrofit Kit Contents: All Parts From the Above 2 Kits

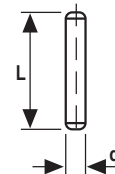
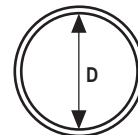

RETAINING PINS AND RINGS

SQUARE DRIVE	THROUGH HEX SIZE	PIN #	RING#	d	L	D
#5	2-3/16-55mm	P9560	R9560	.950	1.950	1.950
#5	Above 2-3/16	P9586	R9586	.950	2.964	2.964

FRACTIONAL SIZES

PART#	SIZE	D	C	L
FSW14	7/8	1-13/16	9/16	6-1/2
FSW15	15/16	1-13/16	9/16	6-1/2
FSW16	1	1-13/16	9/16	6-1/2
FSW17	1-1/16	1-13/16	5/8	7-1/16
FSW18	1-1/8	1-13/16	5/8	7-1/16
FSW19	1-3/16	2-1/16	11/16	7-1/2
FSW20	1-1/4	2-1/16	11/16	7-1/2
FSW21	1-5/16	2-1/16	11/16	7-1/2
FSW22	1-3/8	2-1/16	11/16	7-1/2
FSW23	1-7/16	2-15/16	11/16	8-1/16
FSW24	1-1/2	2-15/16	11/16	8-1/16
FSW25	1-9/16	2-15/16	11/16	8-1/16
FSW26	1-5/8	2-15/16	13/16	9-1/16
FSW27	1-11/16	2-15/16	13/16	9-1/16
FSW28	1-3/4	2-15/16	13/16	9-1/16
FSW29	1-13/16	2-15/16	7/8	9-7/16
FSW30	1-7/8	2-15/16	7/8	9-7/16
FSW31	1-15/16	2-15/16	7/8	9-7/16
FSW32	2	3-1/8	15/16	10-1/16
FSW33	2-1/16	3-1/8	15/16	10-1/16
FSW34	2-1/8	3-1/8	15/16	10-1/16
FSW35	2-3/16	3-3/8	1	10-5/8
FSW36	2-1/4	3-3/8	1	10-5/8
FSW37	2-5/16	3-3/8	1	10-5/8
FSW38	2-3/8	3-11/16	1	11
FSW39	2-7/16	3-11/16	1	11
FSW40	2-1/2	3-11/16	1	11
FSW41	2-9/16	4	1-3/16	11-13/16
FSW42	2-5/8	4	1-3/16	11-13/16
FSW43	2-11/16	4	1-3/16	11-13/16
FSW44	2-3/4	4-5/16	1-5/16	13
FSW45	2-13/16	4-5/16	1-5/16	13
FSW46	2-7/8	4-5/16	1-5/16	13
FSW47	2-15/16	4-5/16	1-5/16	13
FSW48	3	4-5/16	1-5/16	13
FSW49	3-1/16	4-5/16	1-5/16	13
FSW50	3-1/8	4-15/16	1-7/16	14-3/16
FSW51	3-3/16	4-15/16	1-7/16	14-3/16
FSW52	3-1/4	4-15/16	1-7/16	14-3/16
FSW53	3-5/16	4-15/16	1-7/16	14-3/16
FSW54	3-3/8	4-15/16	1-7/16	14-3/16
FSW55	3-7/16	4-15/16	1-7/16	14-3/16
FSW56	3-1/2	4-15/16	1-7/16	14-3/16
FSW57	3-9/16	5-9/16	1-9/16	15-3/8
FSW58	3-5/8	5-9/16	1-9/16	15-3/8
FSW59	3-11/16	5-9/16	1-9/16	15-3/8
FSW60	3-3/4	5-9/16	1-9/16	15-3/8
FSW61	3-13/16	5-9/16	1-9/16	15-3/8
FSW62	3-7/8	5-9/16	1-9/16	15-3/8
FSW63	3-15/16	6-1/8	1-3/4	16-9/16
FSW64	4	6-1/8	1-3/4	16-9/16
FSW65	4-1/16	6-1/8	1-3/4	16-9/16
FSW66	4-1/8	6-1/8	1-3/4	16-9/16
FSW67	4-3/16	6-1/8	1-3/4	16-9/16
FSW68	4-1/4	6-1/8	1-3/4	16-9/16

FRACTIONAL SIZES

PART#	SIZE	D	C	L
FSW69	4-5/16	6-11/16	1-7/8	17-11/16
FSW70	4-3/8	6-11/16	1-7/8	17-11/16
FSW71	4-7/16	6-11/16	1-7/8	17-11/16
FSW72	4-1/2	6-11/16	1-7/8	17-11/16
FSW74	4-5/8	6-11/16	1-7/8	17-11/16
FSW76	4-3/4	7-3/16	2-1/8	18-7/8
FSW78	4-7/8	7-3/16	2-1/8	18-7/8
FSW80	5	7-3/16	2-1/8	18-7/8
FSW82	5-1/8	7-15/16	2-5/16	20-1/2
FSW83	5-3/16	7-15/16	2-5/16	20-1/2
FSW84	5-1/4	7-15/16	2-5/16	20-1/2
FSW86	5-3/8	7-15/16	2-5/16	20-1/2
FSW88	5-1/2	8-1/4	2-5/16	20-1/2
FSW90	5-5/8	8-1/4	2-5/16	20-1/2
FSW92	5-3/4	9	2-1/2	22-13/16
FSW94	5-7/8	9	2-1/2	22-13/16
FSW96	6	9	2-1/2	22-13/16
FSW98	6-1/8	9	2-1/2	22-13/16
FSW100	6-1/4	9	2-1/2	22-13/16
FSW102	6-3/8	9-7/16	2-1/2	22-13/16
FSW104	6-1/2	10-7/16	2-3/4	25-9/16
FSW106	6-5/8	10-7/16	2-3/4	25-9/16
FSW108	6-3/4	10-7/16	2-3/4	25-9/16
FSW110	6-7/8	10-7/16	2-3/4	25-9/16
FSW112	7	10-7/16	2-3/4	25-9/16
FSW114	7-1/8	10-7/16	2-3/4	25-9/16
FSW116	7-1/4	11-7/16	2-15/16	27-9/16
FSW118	7-3/8	11-7/16	2-15/16	27-9/16
FSW120	7-1/2	11-7/16	2-15/16	27-9/16
FSW122	7-5/8	11-7/16	2-15/16	27-9/16
FSW124	7-3/4	11-7/16	2-15/16	27-9/16
FSW125	7-13/16	11-7/16	2-15/16	27-9/16
FSW126	7-7/8	11-7/16	2-15/16	27-9/16
FSW128	8	11-7/16	2-15/16	27-9/16
FSW130	8-1/8	11-7/16	2-15/16	27-9/16
FSW132	8-1/4	12-5/8	3-1/8	29-1/2
FSW134	8-3/8	12-5/8	3-1/8	29-1/2
FSW136	8-1/2	12-5/8	3-1/8	29-1/2
FSW140	8-5/8	12-5/8	3-1/8	29-1/2
FSW142	8-7/8	12-5/8	3-1/8	29-1/2
FSW144	9	12-5/8	3-1/8	29-1/2



Table continued next column

12 POINT OPENING

FLAT STRIKING WRENCHES

METRIC SIZES

PART#	SIZE	D	C	L
FSWM22	22	43	15	165
FSWM23	23	43	15	165
FSWM24	24	43	15	165
FSWM25	25	43	15	165
FSWM26	26	43	15	165
FSWM27	27	46	16	180
FSWM28	28	46	16	180
FSWM29	29	46	16	180
FSWM30	30	52	17	190
FSWM31	31	52	17	190
FSWM32	32	52	17	190
FSWM33	33	52	17	190
FSWM34	34	52	17	190
FSWM35	35	52	17	190
FSWM36	36	58	18	205
FSWM37	37	58	18	205
FSWM38	38	58	18	205
FSWM39	39	58	18	205
FSWM40	40	58	18	205
FSWM41	41	66	20	230
FSWM42	42	66	20	230
FSWM43	43	66	20	230
FSWM44	44	66	20	230
FSWM45	45	66	20	230
FSWM46	46	74	22	240
FSWM47	47	74	22	240
FSWM48	48	74	22	240
FSWM49	49	74	22	240
FSWM50	50	80	24	255
FSWM51	51	80	24	255
FSWM52	52	80	24	255
FSWM54	54	80	24	255
FSWM55	55	86	25	270
FSWM56	56	86	25	270
FSWM57	57	86	25	270
FSWM58	58	86	25	270
FSWM59	59	86	25	270
FSWM60	60	93	26	280

Table continued next column

METRIC SIZES

PART#	SIZE	D	C	L
FSWM61	61	93	26	280
FSWM62	62	93	26	280
FSWM65	65	102	30	300
FSWM67	67	102	30	300
FSWM70	70	110	33	330
FSWM73	73	110	33	330
FSWM75	75	110	33	330
FSWM76	76	110	33	330
FSWM80	80	125	36	360
FSWM85	85	125	36	360
FSWM86	86	125	36	360
FSWM90	90	142	40	390
FSWM95	95	142	40	390
FSWM100	100	115	45	420
FSWM105	105	155	45	420
FSWM110	110	170	48	450
FSWM115	115	170	48	450
FSWM120	120	182	54	480
FSWM125	125	182	54	480
FSWM130	130	202	58	520
FSWM135	135	202	58	520
FSWM140	140	210	58	520
FSWM145	145	228	64	580
FSWM150	150	228	64	580
FSWM155	155	228	64	580
FSWM160	160	240	64	580
FSWM165	165	265	70	650
FSWM170	170	265	70	650
FSWM175	175	265	70	650
FSWM180	180	265	70	650
FSWM185	185	290	75	700
FSWM190	190	290	75	700
FSWM195	195	290	75	700
FSWM200	200	290	75	700
FSWM210	210	320	80	750
FSWM215	215	320	80	750
FSWM225	225	320	80	750
FSWM230	230	320	80	750

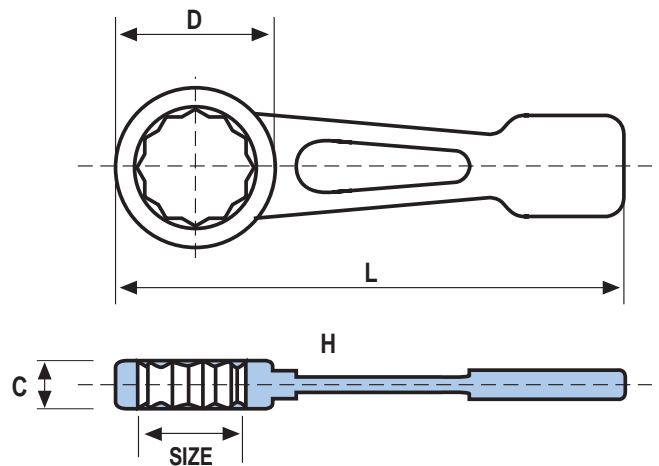

12 POINT OPENING

OFFSET STRIKING WRENCHES

FRACTIONAL SIZES

PART#	SIZE	D	C	L
SW17	1-1/16	2-1/16	1	10-5/8
SW18	1-1/8	2-1/16	1	10-5/8
SW20	1-1/4	2-1/16	1	10-5/8
SW21	1-5/16	2-1/16	1	10-5/8
SW23	1-7/16	2-11/16	1-1/4	12-1/4
SW24	1-1/2	2-11/16	1-1/4	12-1/4
SW26	1-5/8	2-11/16	1-1/4	12-1/4
SW27	1-11/16	3-1/4	1-3/8	13-3/8
SW28	1-3/4	3-1/4	1-3/8	13-3/8
SW29	1-13/16	3-1/4	1-3/8	13-3/8
SW30	1-7/8	3-1/4	1-3/8	13-3/8
SW31	1-15/16	3-1/4	1-3/8	13-3/8
SW32	2	3-1/4	1-3/8	13-3/8
SW34	2-1/8	3-1/4	1-1/2	14-3/16
SW35	2-3/16	3-1/4	1-1/2	14-3/16
SW36	2-1/4	3-1/4	1-1/2	14-3/16
SW37	2-5/16	3-1/4	1-1/2	14-3/16
SW38	2-3/8	4-5/16	1-3/4	15
SW40	2-1/2	4-5/16	1-3/4	15
SW41	2-9/16	4-5/16	1-3/4	15
SW42	2-5/8	4-5/16	1-3/4	15
SW44	2-3/4	5	2	15-3/4
SW46	2-7/8	5	2	15-3/4
SW47	2-15/16	5	2	15-3/4
SW48	3	5	2	15-3/4
SW50	3-1/8	5	2	15-3/4

Striking Wrench Adapter

PART #	DESCRIPTION
FSWA16	1"M x 1"F
FSWA12	3/4"M x 3/4"F



ATP can manufacture specialized striking wrenches to suit your individual applications. Sizes larger than shown in the charts, open ended, short handed, six point, etc. are available on a special order basis.

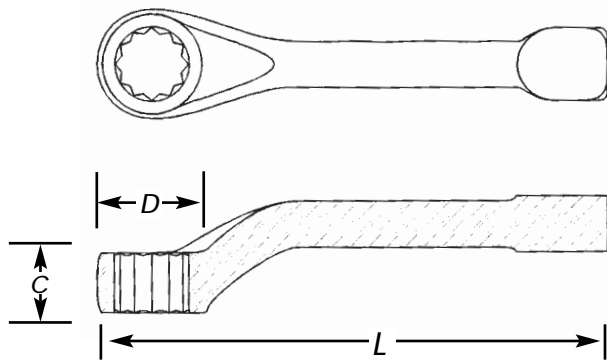

12 POINT OPENING



Field Tested



SAFE **INDUSTRY INNOVATION**
EFFICIENT

OFFSET STRIKING WRENCHES STRIKE FORCE MARK SAFETY

Our strike force has all of the basic features of a regular striking wrench, with one added benefit - it has been engineered with your safety in mind.

Hand related injuries have increased on the job site, some minor, others proving far more serious. Our "Strike Force" striking wrench is simply innovative. We have incorporated a square drive hole into the handle that will accept any standard 1/2" "breaker bar", keeping the users hands away from the point of impact. Combine it with ATP's SWBB-18 breaker bar, designed with a pro-active shock dampener to absorb the "sting", for a safer and more efficient striking wrench system.

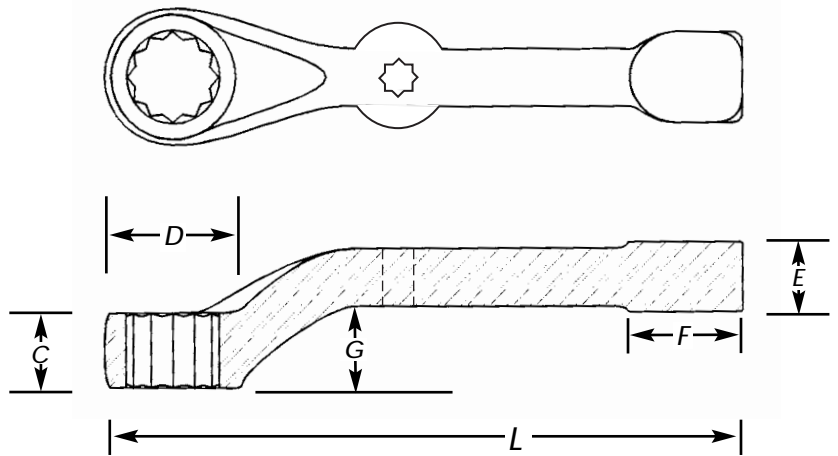

Strike Force Mark Safety Wrenches

Fractional Sizes	Size	D	C	L	E	G	F
Part #							
SW14-SP	7/8"	2-1/16"	13/16"	12"	1-1/4"	1-5/8"	3-1/4"
SW16-SP	1"	2-1/16"	13/16"	12"	1-1/4"	1-5/8"	3-1/4"
SW17-SP	1-1/16"	2-1/16"	13/16"	12"	1-1/4"	1-5/8"	3-1/4"
SW18-SP	1-1/8"	2-1/16"	13/16"	12"	1-1/4"	1-5/8"	3-1/4"
SW19-SP	1-3/16"	2-19/32"	1-1/16"	12"	1-1/4"	1-5/8"	3-1/4"
SW20-SP	1-1/4"	2-1/16"	13/16"	12"	1-1/4"	1-5/8"	3-1/4"
SW21-SP	1-5/16"	2-19/32"	1-1/16"	12"	1-1/4"	1-5/8"	3-1/4"
SW22-SP	1-3/8"	2-19/32"	1-1/16"	12"	1-1/4"	1-5/8"	3-1/4"
SW23-SP	1-7/16"	2-19/32"	1-1/16"	12"	1-1/4"	1-5/8"	3-1/4"
SW24-SP	1-1/2"	2-19/32"	1-1/16"	12"	1-1/4"	1-5/8"	3-1/4"
SW25-SP	1-9/16"	3-1/16"	1-1/4"	14-3/8"	1-1/2"	1-7/8"	3-11/16"
SW26-SP	1-5/8"	3-1/16"	1-1/4"	14-3/8"	1-1/2"	1-7/8"	3-11/16"
SW27-SP	1-11/16"	3-1/16"	1-1/4"	14-3/8"	1-1/2"	1-7/8"	3-11/16"
SW28-SP	1-3/4"	3-1/16"	1-1/4"	14-3/8"	1-1/2"	1-7/8"	3-11/16"
SW29-SP	1-13/16"	3-1/16"	1-1/4"	14-3/8"	1-1/2"	1-7/8"	3-11/16"
SW30-SP	1-7/8"	3-1/16"	1-1/4"	14-3/8"	1-1/2"	1-7/8"	3-11/16"
SW31-SP	1-15/16"	3-1/16"	1-1/4"	14-3/8"	1-1/2"	1-7/8"	3-11/16"
SW32-SP	2"	3-1/16"	1-1/4"	14-3/8"	1-1/2"	1-7/8"	3-11/16"
SW33-SP	2-1/16"	3-1/16"	1-1/4"	14-3/8"	1-1/2"	1-7/8"	3-11/16"
SW34-SP	2-1/8"	3-1/16"	1-1/4"	14-3/8"	1-1/2"	1-7/8"	3-11/16"
SWBB-18	Flex Breaker Bar - 1/2" sq. drive, 18" long						



ATP can manufacture specialized striking wrenches to suit your individual applications. Sizes larger than shown in the charts, open ended, short handled, six point, etc. are available on a special order basis.

All Fractional Offset sizes listed above are also available for Strike Force Mark Safety Wrenches. Other sizes in inch and metric are available upon request.

Torque Multipliers

ATP TM7550 & TM1075

ATP's Torque Multipliers are quality made in the USA and are a must for anybody working in maintenance, production and equipment service where high torque applications are present. Using a planetary gear train at a ratio of 4 to 1, the input torque increases the output torque by 4 times.

Made of the finest quality materials and precision machining the ATP Torque Multipliers will reach torque levels easier and more efficiently. Less stress on the operators means a safer quality of work. Using a standard hand ratchet, torque measuring ratchet or other source of input torque and a socket on the output drive simply place the socket on the item to be turned and brace the reaction bar against a solid fixed object. The force applied to the input will be multiplied 4X to the output. Use for installation or breaking loose stubborn fasteners. The small size can fit into many tight applications where other tools cannot.

ATP's Torque Multipliers can be used in combination to achieve even higher torque values up to the maximum output capacity of the largest multiplier.

TM Specifications

MODEL#	Output Torque*	Input Drive**	Output Drive	Gear Ratio	Weight
TM 7550	1000	1/2"	3/4"	4 to 1	7 Lbs
TM 1075	2000	3/4"	1"	4 to 1	14 Lbs

* Output Torque may vary +/- 10% due to friction loss per multiplier.

** Impact tools should not be used with the ATP Torque Multiplier.

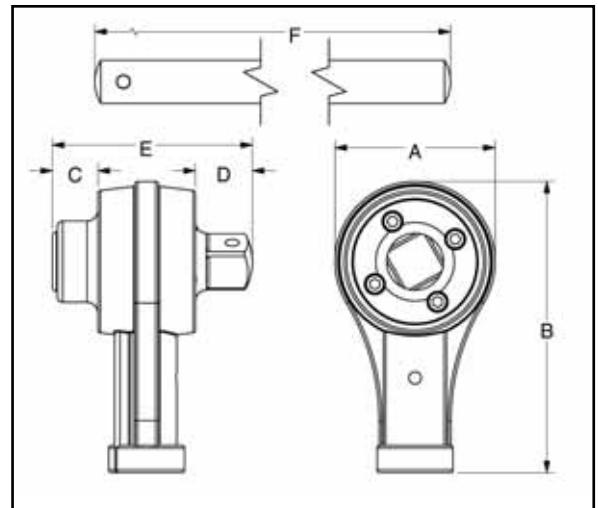

TM7550

- A) 3.50"
- B) 7.00"
- C) 0.50"
- D) 0.75"
- E) 3.50"
- F) 18.88"

Overall Length:
23.50"

TM1075

- A) 3.75"
- B) 6.60"
- C) 0.75"
- D) 1.00"
- E) 4.63"
- F) 20.50"

Overall Length:
24.25"



Reaction Bar Included

OZAT NON STANDARD SPECIALS DESCRIPTION FOR QUOTATION

COMPANY: _____ **CONTACT:** _____

ADDRESS: _____

PHONE No: _____ **FAX:** _____ **E-MAIL:** _____

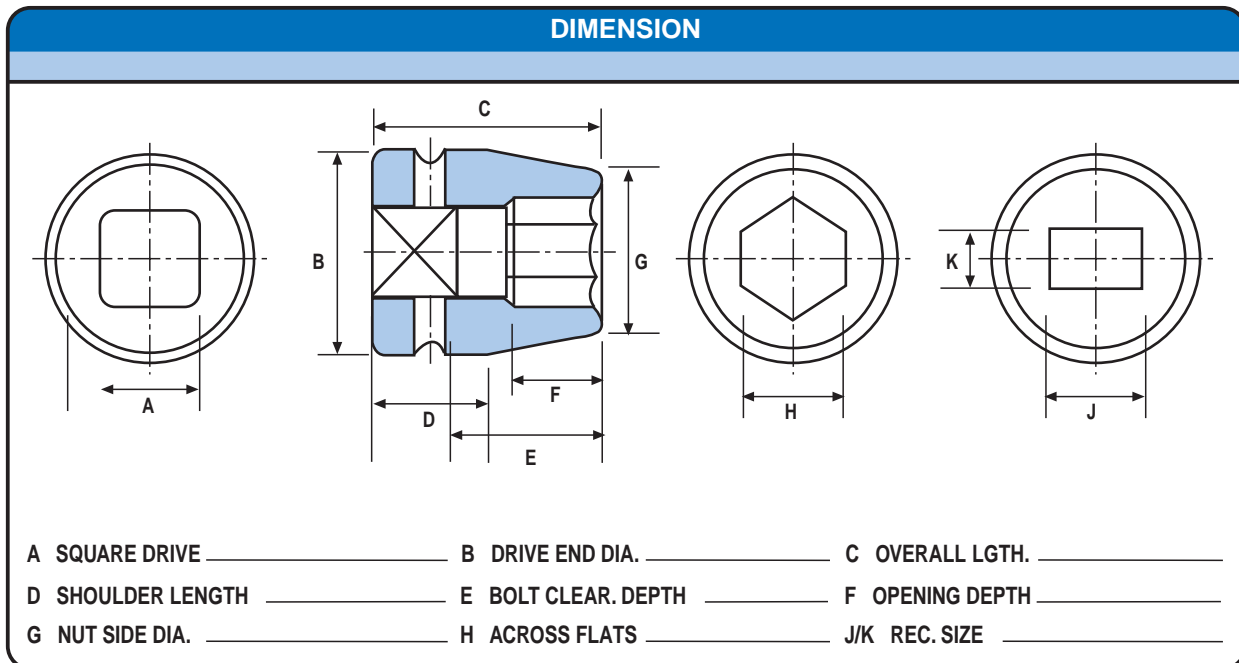
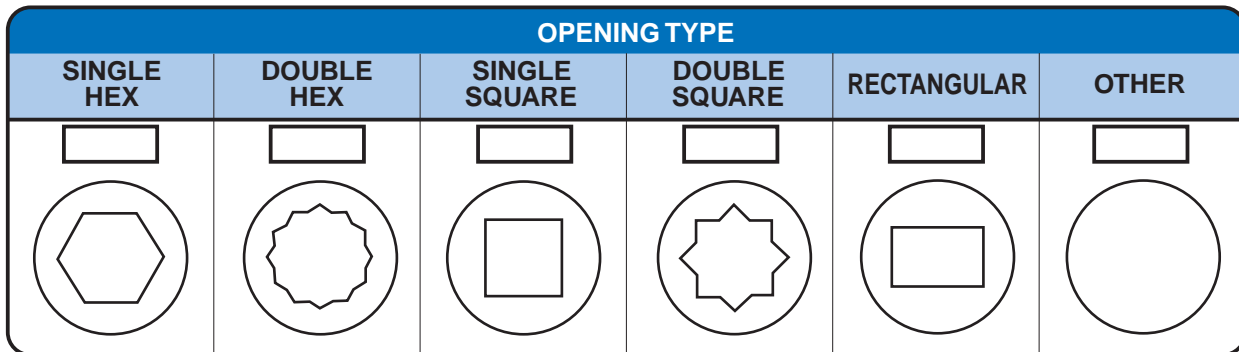
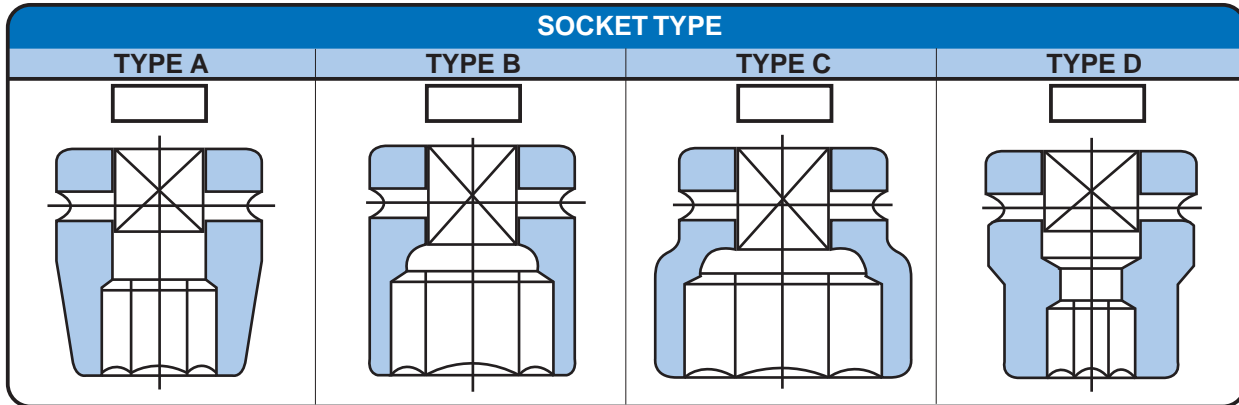

APPLICATION/COMMENTS: _____ **QUANTITY(S)** _____

ATP

Send OZAT specials request for quotation to customer service FAX: (724) 776-6800 or info@hy-techinc.com



Fabricated Metals
Power Generation
Petrochemical
Ship Building
Construction
Refinery
Railroad
Mining

Distributed by: