

NATIONAL-SPENCER INC.
FLUID MANAGEMENT EQUIPMENT

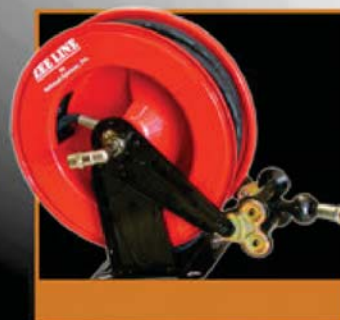

2015

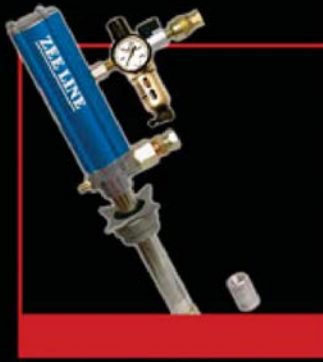
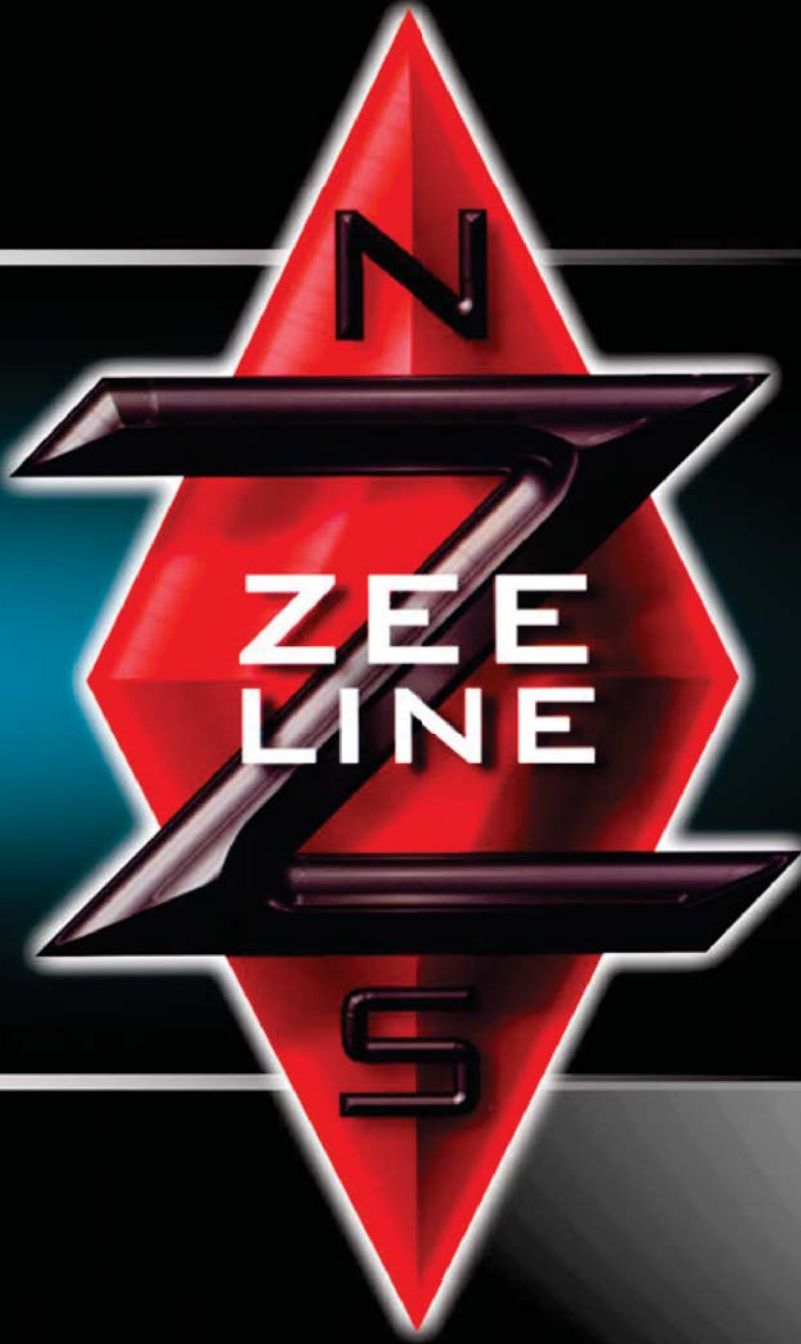

EQUIPMENT PACKAGES

Packages For Oil & Grease Equipment

Save By Ordering Equipment In One Of These Popular Combinations



Packages For Oil Equipment

Part #	Pump	Reel / Hose	Meter / Handle
6104	3:1 Stub (1712)	25-ft Hose (2225)	Digital Quart (1504)
6105	3:1 Stub (1712)	49-ft Reel (1444R)	Digital Quart (1504)
6112	3:1 Stub (1712)	49-ft Reel (1444R)	Mechanical (1515)
6116	3:1 Stub (1712)	32-ft Reel (1475R)	Mechanical (1515)
6120	3:1 Stub (1712)	49-ft Reel (1444R)	Mechanical Preset (1520)
6124	3:1 Stub (1712)	32-ft Reel (1475R)	Digital Quart (1504)
6204	3:1 55-Gallon (1702R)	25-ft Hose (2225)	Digital Quart (1504)
6520	5:1 Stub (1730A)	49-ft Reel (1444R)	Mechanical Preset (1520)



6403
(drum not included)

Packages For Oil Equipment W/ 4-Wheel Drum Cart

Part #	Pump	Reel / Hose	Meter / Handle
6401**	3:1 55-Gallon (1702R)	32-ft Reel (1475R)	Digital Quart (1504)
6403**	3:1 55-Gallon (1714)	32-ft Reel (1475R)	Mechanical (1515)
6404**	3:1 55-Gallon (1702R)	32-ft Reel (1475R)	Mechanical (1515)
6405**	5:1 55-Gallon (1745)	32-ft Reel (1475R)	Digital Quart (1504)

** Includes 4 Wheel Cart (148)



6611

Oil Equipment Packages for Totes

Part #	Pump	Reel / Hose	Meter / Handle
6611***	3:1 Stub (1712)	32-ft. Reel (1475R)	Mechanical (1525)
6612***	3:1 Stub (1712)	32-ft. Reel (1475R)	Mechanical (1515)
6613***	3:1 Stub (1712)	25-ft. Hose (2225)	Digital (1504)
6614***	3:1 Stub (1712)	32-ft. Reel (1475R)	Digital (1504)

*** Includes Tote Bracket (6601) & Suction Tube for Totes (15216)



1213R

1536A

1440R

Packages For Grease Equipment

Part #	Pump	Reel / Hose
6167	65:1 120-lb. (1213R Less Dolly)	52-ft Reel (1440R)
6168	50:1 120-lb. (1220R Less Dolly)	35-ft Reel (1474R)

◇All packages include an air filter with nighttime water drain, regulator, gauge, ball valve, quick disconnects (1559A-ASSY) and all connecting components

◇Create your own package and receive the same great savings (call for price quote)

TOP TWELVE BEST SELLERS



CATALOG INDEX



EQUIPMENT PACKAGES

Oil & Grease Equipment Packages

Inside Cover

OILS, GEAR LUBE, ATF



Pumps-Double Diaphragm	3-5
Meters	7-13
Control Handles	14
Pumps-Air Operated	6, 15-21
Oil Dispensing Systems	22
Pumps-Electric	22
Oil Bars	23
Pumps-Manual	24-29
Waste Oil Drains	30, 32-33
Evacuation Units	31
Truck Oil Drains	34

GREASE



Pumps-Air Operated	35-40
Control Handles	41
Follower Plates	42
Pumps-Manual	43
Bearing Packers	44
Pumps-Filler	45
Grease Guns	46-53, 55
Grease Gun Accessories	54, 58-60
Grease Fittings	56-57

FUELS



Pumps-Electric	61-63
Fuel Nozzles	64
DEF Pumps-Manual	65-66
DEF Pumps-Air Operated & Electric	65,67
DEF Accessories	68
Fuel Filters	70
Meters	63
Pumps-Manual	69
Pumps-Rotary	71-73

CHEMICALS



Pumps-Rotary	95-96, 99
Pumps-Manual	97-99, 101
Pumps-Air Operated & Electric	100, 101
Chemical Chart	102,103

ACCESSORIES



Air Controls	74
Hose Assemblies	75
Hose Reels	76-79
Parts Washers	80
Waste Receptacles	80
Drum Handling Equipment	81-85
Automotive Accessories	86
Funnels	87-89
Measures	90-91
Cleaning Accessories	92
Breathers	93

DOUBLE DIAPHRAGM PUMPS

OIL

Air Operated Pumps: Non-stalling, Lube-free

Recommended for Motor Oil, Waste Oil, ATF, Gasoline & Diesel Fuel

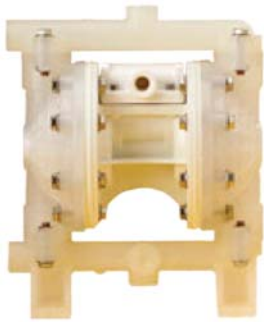

PART# 1035



PART# 1038

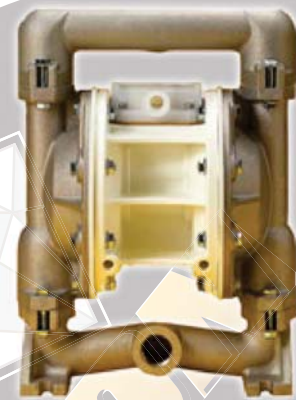

PART# 1040

Features

- Polypropylene or Aluminum/Poly Construction
 - Recommended for Oil, Waste Oil & ATF
- WARNING! Not suitable for flammable liquid*

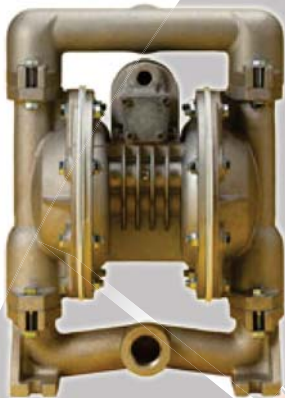

PART# 1040UL

Features

- Aluminum or Stainless Steel Construction
- 1040UL Recommended for Gasoline & Diesel Fuel. Includes grounding cable
- 1040SS Recommended for Diesel Fuel, Bio Diesel, & Mild Chemicals

PART# 1040SS

WARNING! When pumping flammable liquids use proper grounding



Specifications

Part #	1035	1037	1038	1040	1040UL	1040SS
Inlet/Outlet	1/2" NPT	1/2" NPT	3/4" NPT	1" NPT	1" NPT	1" NPT
Max. Flow	14 GPM	14 GPM	14 GPM	37 GPM	37 GPM	37 GPM
Body Construction	Polypropylene	Polypropylene	Alum / Polypro	Alum / Polypro	Aluminum	Stainless Steel
Diaphragm	Buna N	Buna N	Buna N	Buna N	Buna N	PTFE
Balls	Acetal	Acetal	Acetal	Acetal	PTFE	PTFE
Seats	Polypropylene	Polypropylene	Aluminum	Aluminum	Aluminum	Stainless Steel
UL Listed	NO	NO	NO	NO	YES	NO
Air Consumption	16CFM @ 100 PSI	16CFM @ 100 PSI	16CFM @ 100 PSI	40CFM @ 80 PSI	30CFM @ 50 PSI	40CFM @ 80 PSI

Part# 1037 Includes 1/2" 4-ft. oil hose (2204) (2ea.) and Air line filter assembly (1559A2-ASSY)

Dimensions

Part #	1035	1037	1038	1040	1040UL	1040SS
Bolt Pattern	4.375" X 6.750"	4.375" X 6.750"	3.250" X 4.370"	4.250" X 8.250"	4.250" X 8.250"	4.250" X 8.250"
Height	10.600" Tall	10.600" Tall	10.250" Tall	14.125" Tall	14.125" Tall	14.125" Tall

DOUBLE DIAPHRAGM PUMPS

High-flow Cast Aluminum Industrial Pumps

Recommended for Motor Oil, Waste Oil & Water



PART# 1041



PART# 1043



PART# 1044

Air Operated 1:1 Double Diaphragm Pumps

Features

- Self-priming
- Corrosion resistant air section
- Can handle infinite variable flows up to 90% solids
- Clamp-band construction

WARNING! Not suitable for flammable liquid

Specifications

Part #	1041	1043	1044
Inlet/Outlet	1 1/2" NPT	2" NPT	3" NPT
Max. Flow	72 GPM	155 GPM	260 GPM
Air inlet Port	1/2" NPT	1/2" NPT	1/2" NPT
Max Particle Size	3/16"	1/4"	3/8"
Suction Lift Dry	15 - ft.	20 - ft.	20 - ft.
Suction Lift Wet	25 - ft.	25 - ft.	25 - ft.
Body Construction	Aluminum	Aluminum	Aluminum
Diaphragm	Buna N	Buna N	Buna N
Balls	Buna N	Buna N	Buna N
Seats	Buna N	Buna N	Buna N
UL Listed	NO	NO	NO
Air Consumption	50CFM @ 80 PSI	100CFM @ 100PSI	100CFM @ 100PSI

Dimensions

Part #	1041	1043	1044
Bolt Pattern	6.00" X 8.750"	10.00" X 9.00"	10.00" X 14.250"
Height	18.00" Tall	26.500" Tall	32.750" Tall

DOUBLE DIAPHRAGM PUMPS

Kits And Recommended Accessories

OIL



PART# 1035K / 1040K



(1035K Shown)

Contents of pump and kit packages:

Specifications

Description	QTY	1035K	1040K	1035K2
1/2" Pump (1035)	1	Included	No	Included
1" Pump (1040)	1	No	Included	No
Male Cam Lock	1	3/4" (61961)	1" (61962)	3/4" (61961)
Female Cam Lock	1	3/4" (61921)	1" (61922)	3/4" (61921)
Brass Ball Valve	3	3/4"	1"	3/4"
Hydraulic Adapter Swivel	2	1/2" X 3/4"	1" X 1"	1/2" X 3/4"
Galvanized Steel Street L	1	3/4"	1"	3/4"
Suction Hose	1	3/4" X 8-FT	1" X 8-FT	3/4" X 8-FT
Discharge Hose	1	3/4" X 8-FT	1" X 8-FT	3/4" X 8-FT
Nipple	2	3/4" X 2"	1" X 2"	3/4" X 2"
Strainer	1	3/4"	1"	3/4"
Wall Mount Bracket (96)	1	Yes	Yes	Yes
Airline Filter (1559A2-ASSY)	1	Yes	Yes	Yes
Reducer Bushing (1035RB)	1	No	Yes	Yes



Kits Only (pump not included)

PART# 103501 **PART# 104001**

PART# 98

Diaphragm Pump Adapter
Mounts directly to 2" NPT bung on drums and tanks



Diaphragm Pump and Adapter Kits:

Part#	Pump Hose	Control Handle
9810	2210 (10-ft)	1572R
9825	2225 (25-ft)	1572R

Recommended Accessory Options:

PART# 96



- Wall mount bracket
- 6" Wide x 11" Deep

PART# 1559A2-ASSY



- Air line filter with nighttime drain, regulator, gauge, ball valve and quick disconnects

OIL

VACUUM PUMP

Industrial Shop-Vac

Picks Up And Transfers All Non-Flammable Fluids



PART# 1785

Converts 55 or 120-gallon container into recovery tank



Features

- No Moving Parts
- Automatic shutoff when container is full

Specifications

Part#	1785
Bung Size	Standard 2" NPT
Max. Particulate Size	3/4" Diameter
Max. Transfer Rate	15 GPM (Water)
Hose	Flexible 6-ft. Vacuum Hose (1" I.D.)
Pump Size	6 11/16" X 6 11/16" X 2 3/4"
Air Connection	1/4" NPT
Construction Material	Blue Anodized Aluminum
Air Consumption	9 CFM @ 60 PSI

Optional Accessory

PART# 108-5110

- 5-gallon recovery container



Application

- Waste oil transfer / Cutting fluids
- Paint booth water boxes
- Marinas & Many other industrial uses

DIGITAL PRESET METERS

OIL

Dispenses in Pints, Quarts, Liters, & Gallons

Recommended for Motor Oil, Gear Lube, ATF, and Glycol



PART# 1517

Features

- Safety lock to prevent accidental operation
- Formable hose
- Impact resistant plastic cover and trigger
- Die cast zinc housing
- Lightweight and ergonomically friendly

Specifications

Part#	1517	1522
Dispenses	Pints, Quarts, Liters, & Gallons	Pints, Quarts, Liters, & Gallons
Totalizes	Pints, Quarts, Liters, & Gallons	Pints, Quarts, Liters, & Gallons
Inlet / Outlet	1/2" NPT Threads	1/2" NPT Threads
Nozzle	Flexible, Automatic Non-Drip	1/2" Pipe, Automatic Non-Drip
Max PSI	725 PSI	1000 PSI
Max Flow	4 GPM	8 GPM
Accuracy	±1%	To Second Decimal
Batteries	2 AAA	4 AA
Inlet Swivel	1/2" Swivel	1/2" Swivel (64082-001)
Safety Lock	YES	Trigger Guard



PART# 1522

Features

- Factory programmed and calibrated
- 5 digit display with .01 increment
- Lightweight and rugged with comfort grip

Dispenses in Quarts, Liters, & Gallons

Recommended for Motor Oil, Gear Lube, ATF, and Glycol

PART# 1519 & 1520

Features

- Extremely durable for indoor & outdoor applications
- Large easy to read dial



PART# 1519



PART# 1520

Specifications

Part #	1519	1519L	1520	1520L	1520GG
Dispenses	Quarts	Liters	Quarts	Liters	Gallons
Totalizes	Quarts	Liters	Gallons	Liters	Gallons
Preset	1-16 Quarts	1-16 Liters	1-60 Quarts	1-60 Liters	1-60 Gallons
Graduated	1/2 Quarts	1/2 Liters	1 Quarts	1 Liters	1 Gallons
Inlet / Outlet	1/2" NPT Threads	1/2" NPT Threads	1/2" NPT Threads	1/2" NPT Threads	1/2" NPT Threads
Nozzle	1/2" Pipe, Automatic Non-Drip (1340)	1/2" Pipe, Automatic Non-Drip (1340)	1/2" Pipe, Automatic Non-Drip (1340)	1/2" Pipe, Automatic Non-Drip (1340)	1/2" Pipe, Automatic Non-Drip (1340)
Max PSI	1000 PSI	1000 PSI	1000 PSI	1000 PSI	1000 PSI
Max Temp	150°	150°	150°	150°	150°
Max Flow	4.0 GPM	4.0 GPM	4.0 GPM	4.0 GPM	4.0 GPM
Min Flow	0.4 GPM	0.4 GPM	0.4 GPM	0.4 GPM	0.4 GPM
Accuracy	±0.65%	±0.65%	±0.65%	±0.65%	±0.65%
Inlet Swivel	1/2" Swivel (1101)	1/2" Swivel (1101)	1/2" Swivel (1101)	1/2" Swivel (1101)	1/2" Swivel (1101)

DIGITAL METERS

OIL

Dispenses in Pints, Quarts, Liters, & Gallons

Recommended for Motor Oil, Gear Lube, ATF, and Glycol



PART# 1509

Features

- Resettable dispenser
- Non Resettable Totalizer
- Unit of measure selectable from the front of register
- Cast aluminum housing
- Scratch resistant oven baked epoxy finish
- Easy to read 4 digit LCD with .01 increment
- Long life field replaceable top load battery (CR123A)



PART# 1510

Features

- Safety lock to prevent accidental operation
- Impact resistant plastic cover and trigger
- Die cast zinc housing
- Batteries (2 AAA)

Specifications

Part #	1509	1510
Dispenses	Pints, Quarts, Liters, & Gallons	Pints, Quarts, Liters, & Gallons
Totalizes	Gallons or Liters	Gallons or Liters
Inlet / Outlet	1/2" NPT Threads	1/2" NPT Threads
Nozzle	1/2" Pipe, Automatic Non-Drip (1340)	Formable Hose, Automatic Non-Drip
Max PSI	1500 PSI	725 PSI
Max Temp	150°	150°
Max Flow	4.0 GPM	4.0 GPM
Min Flow	0.25 GPM	0.4 GPM
Accuracy	±0.5%	±1.0%
Inlet Swivel	1/2" Swivel (1101)	1/2" Swivel (1101)

Dispenses in Pints, Quarts, Liters, & Gallons
Recommended for Motor Oil, Gear Lube, & ATF

PART# 1590

High Flow Meter (1590AR Meter Only)
20 Gallons Per Minute

Features

- Oval gear driven meter
- Large LCD display with two decimal point precision
- Field replaceable battery
- “Protective Rubber Boot Optional” (629)

Specifications

Part #	1590
Max Flow	20.0 GPM
Dispenses	Pints, Quarts, Liters, & Gallons
Totalizes	Gallons or Liters
Inlet / Outlet	3/4" NPT Threads
Nozzle	Hose W/ Automatic Non-Drip (38037)
Control Handle	Included (33150)
Handle Adapter	Included (33117)
Temp Range	4° to 140°
Accuracy	±0.5%
Inlet Swivel	1/2" Swivel (1101)



WIRELESS OIL MANAGEMENT SYSTEM

PART# OMS900524E

RF Meter system for fluid inventory management and control

Manages up to 30 meters using wireless 2.4 ghz technology

Features

- 4 hours installation time
- Range 300-ft. (unobstructed)
- Built in ticket printer
- External printer may be added
- One meter included with each system
- Accommodates up to 30 meters per keypad
- Accommodates up to 8 fluids per keypad
- Operates in liters, gallons, pints or quarts
- Maximum of 49 technicians may use the system
- Vehicle mileage may be entered
- Maximum of 1 supervisor password
- Self diagnostic system
- Good for oil and Antifreeze

Available options

- Remote antenna, 30-ft cable only (64722-007)
- Additional meter (1522RF24)

1522RF24



110 Volt Keypad (OMS900724E)

NEW

2.4ghz System

PART# 1522RF24

RF equipped digital preset meter for use with this wireless system

FEATURES

- The amount of fluid dispensed is preset and controlled by the keypad
- Top off feature may be implemented once the meter has stopped
- Meter uses 4 AA batteries. Due to auto stand by, battery life is expected to last 6 months
- Outlet and Spout (1341)

DIGITAL METERS

Dispenses in Pints, Quarts, Liters, & Gallons
Recommended for Motor Oil, Gear Lube, ATF, and Glycol

OIL

NEW
IMPROVED HANDLE

PART# 1504



PART# 1507



Swivel Guard

Features For All Models

- Resettable Dispenser & Non Resettable Totalizer
- Unit of measure selectable from the front of register
- Sealed Display
- Long life field replaceable top load battery (CR123A)
- 3 1/2" Easy to read dial: 6 digit display W/.01 increments

PART# 1504AR

- Meter only



Outlet

Inlet

Specifications

Part #	1504	1504AR	1507
Dispenses	Pints, Quarts, Liters, & Gallons	Pints, Quarts, Liters, & Gallons	Pints, Quarts, Liters, & Gallons
Totalizes	Gallons or Liters	Gallons or Liters	Gallons or Liters
Inlet / Outlet	1/2" NPT Threads	1/2" NPT Threads	1/2" NPT Threads
Shroud	Rubber Shroud (66339-001)	None	Rubber Shroud (66339-001)
Nozzle	Ext. Hose, Automatic Non-Drip (1315A)	None	Flex Hose, Manual Non-Drip (1315)
Handle	Control Handle (1572RAR)	None	Control Handle (1576)
Inlet Swivel	1/2" Swivel (1101)	None	1/2" Swivel (1101)
Max PSI	1500 PSI	725 PSI	725 PSI
Max Temp	140°	150°	150°
Max Flow	4.0 GPM	6.6 GPM	4.0 GPM
Min Flow	0.25 GPM	0.4 GPM	0.4 GPM
Accuracy	±0.5%	±1.0%	±1.0%
Battery	CR123A	CR123A	CR123A

Dispenses in Quarts, Liters, & Gallons

Recommended for Motor Oil, Gear Lube, ATF, and Glycol



PART# 1508



PART# 1515



PART# 1515A

Available Models / Specification

Part#	Dispenses	Totalizes	Dial Reads	Graduated	Nozzle
1508	Quarts	Quarts	1-16 Quarts	1/4 Quarts	Part# 1340
1508L	Liters	Liters	1-10 Liters	1/10 Liters	Part# 1340
1508Q	Quarts	Quarts	1-16 Quarts	1/4 Quarts	Part# 1335
1508G	Quarts	Gallons	1-16 Quarts	1/4 Quarts	Part# 1340
1508GG	Gallons	Gallons	1-16 Gallons	1/4 Gallons	Part# 1340
1515	Quarts	Quarts	1-16 Quarts	1/4 Quarts	Part# 1315
1515L	Liters	Liters	1-10 Liters	1/10 Liters	Part# 1315
1515A	Quarts	Quarts	1-16 Quarts	1/4 Quarts	Part# 1315A
1515G	Quarts	Gallons	1-16 Quarts	1/4 Quarts	Part# 1315
1515GG	Gallons	Gallons	1-16 Gallons	1/4 Gallons	Part# 1315

Specifications For All Models

Inlet/Outlet	Max. Flow	Min. Flow	Max Psi.	Max Temp	Accuracy	Dial Size
1/2" NPT	4.0 GPM	0.25 GPM	1000 PSI	150°	±0.65%	3 1/2"

Includes 1/2" inlet swivel adapter **PART# 1101**



PART# 1340
(1/2" Pipe W/Automatic Nozzle)



PART# 1315A
(14" Hose W/Automatic Nozzle & Swivel)



PART# 1315
(14" Hose W/Manual Nozzle)



PART# 1335
(3/8" Pipe W/Manual Nozzle)

MECHANICAL METERS

Dispenses in Pints or Quarts
Recommended for Motor Oil, Gear Lube, & ATF

OIL

NEW

PART# 1503



PART# 1525



PART# 1525AR (Meter Only)



PART# 1525BC



Part #	1503	1525	1525BC
Dispenses	Pints	Quarts	Quarts
Totalizes	Pints	Quarts	Quarts
Inlet / Outlet	1/2" NPT Threads	1/2" NPT Threads	1/2" NPT Threads, 3/8" Outlet Threads
Shroud	None	Rubber Shroud	Rubber Shroud
Nozzle	90° Pipe Ext w/ Non-Drip(1315A)	Ext. Hose, Automatic Non-Drip(1315A)	Rigid Extension w/Auto Non-Drip
Handle	Integrated	Control Handle (1572)	Integrated w/Trigger Lock & Guard
Inlet Swivel	1/2" Swivel (1101)	1/2" Swivel (1101)	1/2" Swivel

IN LINE METERS



PART# 1500

For dispensing up to 8-pints
Registers in 1/4-pint increments
Non-totalizing



PART# 1502

For dispensing and totalizing up to 8-pints
Registers in 1/4-pint increments



PART# 1505

For dispensing and totalizing up to 16-quarts
Registers in 1/4-quart increments

Specifications For All Models

Inlet/Outlet	Max. Flow	Min. Flow	Max Psi.	Max Temp	Accuracy	Dial Size
1/2" NPT	4.0 GPM	0.40 GPM	1000 PSI	150°	±0.65%	3 1/2"
Dial rotates in 90° increments to change outlet orientation						

Oil Meter Accessories

For use with Manual or Electronic Meters



PART# 1101



PART# 26



PART# 26A



PART# 1315



PART# 1315A



PART# 1326



PART# 1330



PART# 1335



PART# 1340

Part#	Description	Thread Size
26	Manual non-drip nozzle	1/4" NPT
26A	Automatic non-drip nozzle	1/4" NPT
1101	Swivel adapter	1/2"(M) x 1/2"(F) NPT
1315	14" hose w/manual non-drip nozzle (26)	1/2" x 1/4" NPT
1315A	14" hose w/automatic non-drip nozzle (26A)	1/2" x 1/4" NPT
1326	16" 90° bent pipe w/manual non-drip nozzle (26)	1/2" x 1/4" NPT
1330	8" 30° bent pipe w/manual non-drip nozzle (26)	1/2" x 1/4" NPT
1335	8" 15° bent pipe w/manual non-drip nozzle (26)	1/2" x 1/4" NPT
1340	6" straight pipe w/automatic non-drip nozzle	1/2" NPT

PART# 91

Wall Mount Bracket



PART# 92

Suction Kit



Oil Control Handles

For use with Oil, Gear Lube, and ATF



PART# 1572



PART# 1572R



PART# 1575

Locking Trigger



PART# 1576



PART# 1580

Locking Trigger

NEW
IMPROVED STYLE



Rubber Swivel Guard

(Included with the 1575, 1576, & 1580)



PART# 1587

Part#	Outlet	Swivel
1572		Included
1572R	Pipe	Included
1575	Hose (1315)	Included
1576		Included
1580	Pipe (1330)	Included
1587	Hose (1315)	Included

PART# 786

Oil Meter Holder & Drip Tray



AIR OPERATED OIL PUMPS

OIL

1:1 Ratio Stub Style Pumps

Recommended For Delivery Of Oil Based Fluids

PART# 1737

IMPORTANT! Not suitable for water based fluids



Air Hose
2004



Oil Hose
2204



Included Accessories

- (28623) Pressure relief valve

Specifications

Part #	1737	1735R
Max. Delivery	6 GPM (1:1 Ratio)	6 GPM (1:1 Ratio)
Max. Fluid Viscosity	80/90 SAE	80/90 SAE
Max. Fluid PSI	145 PSI	110 PSI
Max. Air PSI	145 PSI	110 PSI
Air Consumption	12.36 CFM @ 100 PSI	8.12 CFM @ 100 PSI
Air Inlet	1/4" NPT	1/4" NPT
Fluid Inlet	1" NPT	1" NPT
Fluid Outlet	3/4" NPT (w/1/2" NPT Adapter)	3/4" NPT (w/1/2" NPT Adapter)
Oil Hose	1/2" x 4-ft (2204)	1/2" x 4-ft (2204)
Air Hose	1/4" x 4-ft (2004)	1/4" x 4-ft (2004)
Pump Length	21 11/16"	21.75"
Foot Valve W/ Screen	200-171	KR3308
Bung Adapter	28595	38042
Pressure Relief Valve	28623	Optional (28625)
Air Line Filter Package	1559A-ASSY	1559A-ASSY

PART# 1735R

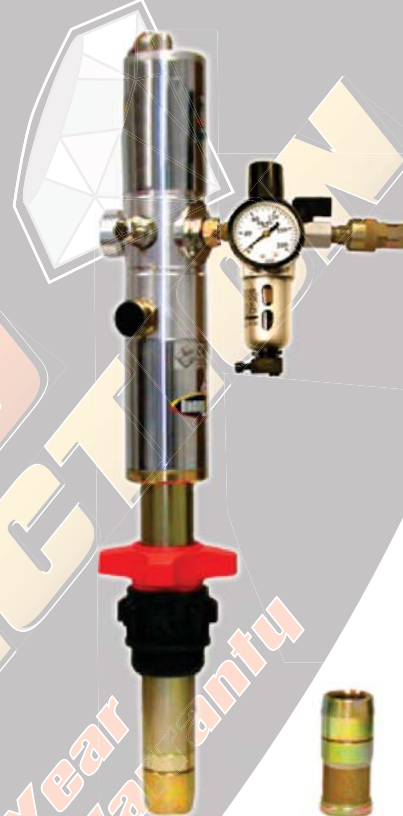

Optional Accessories

- (28625) Pressure relief valve



OIL

AIR OPERATED OIL PUMPS

3:1 Ratio With Power Pump Valve

Recommended For Delivery Of Oil Based Fluids

IMPORTANT! Not suitable for water based fluids



PART# 1712PPV

3:1 Ratio Oil Pump (1714)
With Meter (1505)

PART# 1722

3:1 Ratio Oil Pump (1714)
With Spigot (1608R)

PART# 1527

Power Pump Valve With
meter

PART# 1529

Power Pump Valve



Features

- Register to 16-quarts per delivery
- Totalizes to 9,999 quarts
- Quart meter included (1505)
- Self closing & lock open valve handle

Specifications

Part #	1712PPV	1722
Oil Pump	3:1 Ratio Oil Pump (1714)	3:1 Ratio Oil Pump (1714)
Meter	In-Line Meter (1505)	NA
Power Pump Valve	Power Pump Valve W/Meter (1527)	Power Pump Valve (1529)
Max. Delivery	5 GPM (3:1 Ratio)	5 GPM (3:1 Ratio)
Max. Fluid Viscosity	80/90 SAE	80/90 SAE
Max. Fluid PSI	435 PSI	435 PSI
Max. Air PSI	145 PSI	145 PSI
Air Consumption	17.02 CFM @ 100 PSI	17.02 CFM @ 100 PSI
Air Inlet	1/4" NPT	1/4" NPT
Fluid Inlet	3/4" NPT	3/4" NPT
Fluid Outlet	3/4" NPT (w/1/2" NPT Adapter)	3/4" NPT (w/1/2" NPT Adapter)
Air Hose	1/4" x 4-ft (2004)	1/4" x 4-ft (2004)
Pump Length	21 11/16"	22 11/16"
Foot Valve W/ Screen	770-433	770-433
Bung Adapter	28585	28585
Pressure Relief Valve	28623	28623
28" Exstension Tube	15212	15212
Air Line Filter Package	1559A-ASSY	1559A-ASSY

PART# 1608R

Spigot Only
Self Closing or Lock Open



*Available in non locking open (Part# 1608RNL)

AIR OPERATED OIL PUMPS

OIL

3:1 Ratio Oil Pumps

Recommended For Delivery Of Oil Based Fluids



IMPORTANT! Not suitable for water based fluids

PART# 1712 Series

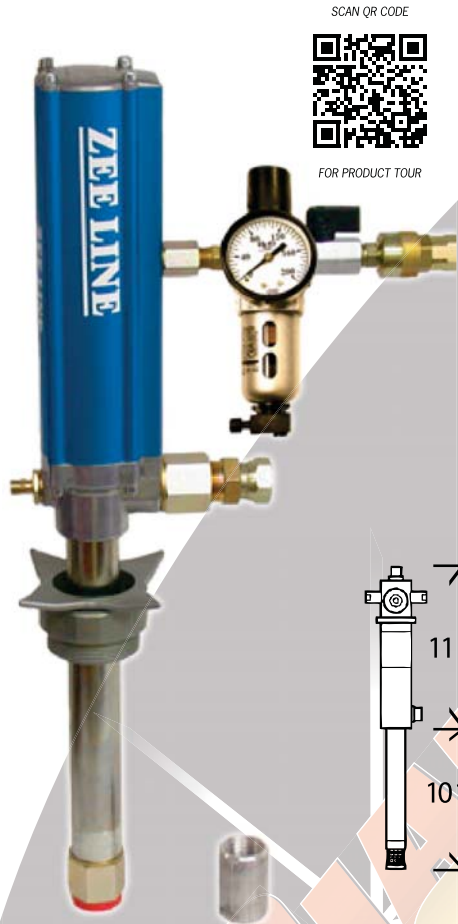

FOR PRODUCT TOUR

Part#	Fits	Extension	Drum Cover
1712	Stub	None	None
1713	16-gal drum	PVC 3/4" x 24" (15210)	Included (680-823)
1714	55-gal drum	PVC 3/4" x 28" (15212)	None
1716	275-gal drum	PVC 3/4" x 36" (15214)	None

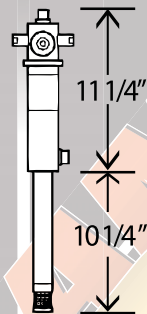

Specifications

Part #	1712 Series
Max. Delivery	5 GPM (3:1 Ratio)
Max. Fluid Viscosity	80/90 SAE
Max. Fluid PSI	435 PSI
Max. Air PSI	145 PSI
Air Consumption	17.02 CFM @ 100 PSI
Air Inlet	1/4" NPT
Fluid Inlet	3/4" NPT
Fluid Outlet	3/4" NPT (w/1/2" NPT Adapter)
Air Hose	1/4" x 4-ft (2004)
Pump Length	21 11/16"
Foot Valve W/ Screen	770-433
Bung Adapter	28585
Pressure Relief Valve	28623
Air Line Filter Package	1559A-ASSY

PART# 28623

Pressure relief valve
Recommended and included with this
air operated oil pump.

Prevents damaging back pressure on
pumps, meters and reels

Releases pressure at 900 PSI



3:1 Ratio Oil Pumps

Recommended For Delivery Of Oil Based Fluids & Antifreeze

PART# 1700R

Stub Style Single Action
3:1 Oil Pump

For dispensing fluid from various sized containers
(see chart below for recommended tube length)

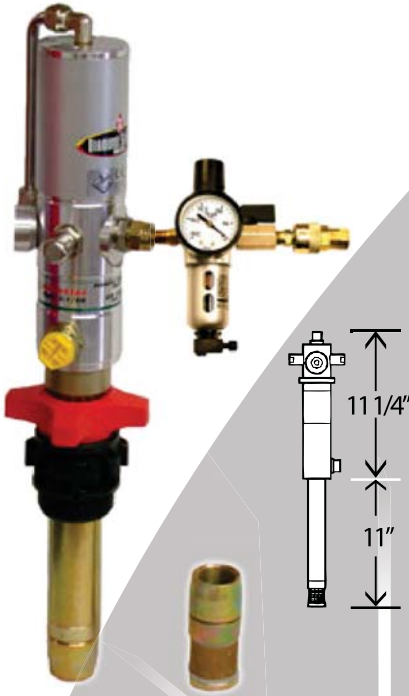

PART# 1702R

Single Action 3:1 Oil Pump

1 1/2" diameter pickup tube
Fits 55-gallon drum

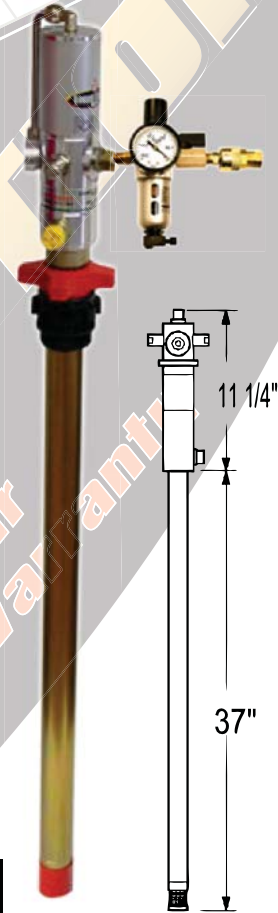

Optional Extensions (PVC):

Part#	Fits	Extension
15219	16-gal drum	PVC 1" x 24"
15221	55-gal drum	PVC 1" x 28"
15222	275-gal drum	PVC 1" x 36"

Specifications

Part #	1700R	1702R
Max. Delivery	3.7 GPM (3:1 Ratio)	3.7 GPM (3:1 Ratio)
Max. Fluid Viscosity	80/90 SAE	80/90 SAE
Max. Fluid PSI	330 PSI	330 PSI
Max. Air PSI	110 PSI	110 PSI
Air Consumption	12 CFM @ 100 PSI	12 CFM @ 100 PSI
Air Inlet	1/4" NPT	1/4" NPT
Fluid Inlet	1" NPT	1" NPT
Fluid Outlet	1/2" NPT	1/2" NPT
Oil Hose	1/2" x 4-ft (2204)	1/2" x 4-ft (2204)
Air Hose	1/4" x 4-ft (2004)	1/4" x 4-ft (2004)
Pump Length	22 1/4"	48 1/4"
Foot Valve W/ Screen	KR3308	KR3308
Bung Adapter	38042	38042
Pressure Relief Valve	Optional (28625)	Optional (28625)
Air Line Filter Package	1559A-ASSY	1559A-ASSY

Optional Accessories PART# 28625

Pressure relief valve

•Prevents damaging back pressure on pumps, meters and reels. It is highly recommended for this pump.



AIR OPERATED OIL PUMPS

OIL

5:1 Ratio Oil Pumps

Recommended For Delivery Of Oil Based Fluids

IMPORTANT! Not suitable for water based fluids



PART# 1730A

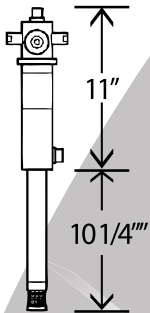
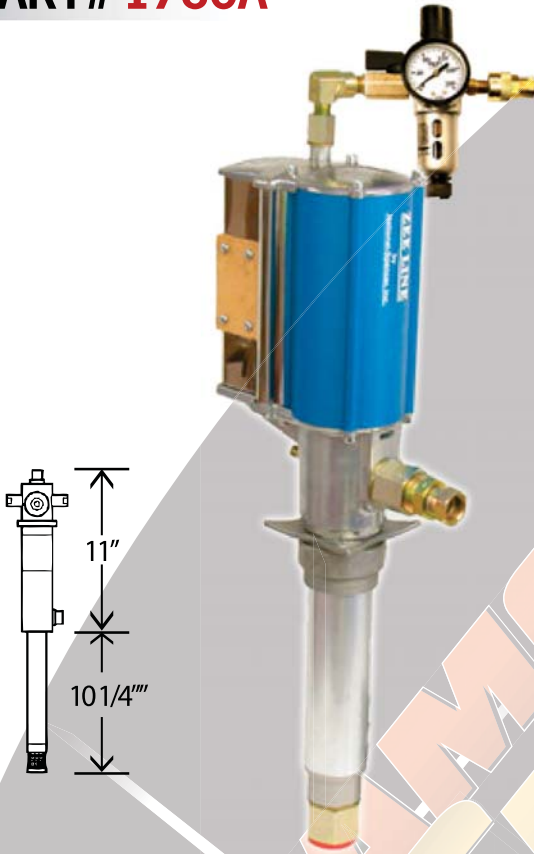

Specifications

Part #	1730A
Max. Delivery	5 GPM (5:1 Ratio)
Max. Fluid Viscosity	240 SAE
Max. Fluid PSI	725 PSI
Max. Air PSI	145 PSI
Air Consumption	29.06 CFM @ 100 PSI
Air Inlet	1/4" NPT
Fluid Inlet	1" NPT
Fluid Outlet	3/4" NPT (w/1/2" NPT Adapter)
Air Hose	1/4" x 4-ft (2004)
Oil Hose	1/2" x 4-ft (2204)
Pump Length	21 1/4"
Foot Valve W/ Screen	200-171
Bung Adapter	28595
Pressure Relief Valve	28623
Air Line Filter Package	1559A-ASSY

PART# 28623

Pressure relief valve (included W/pump)

Prevents damaging back pressure on pumps, meters and reels

Releases pressure at 900 PSI



Optional Extensions (PVC):

Part#	Fits	Extension
15219	16-gal drum	PVC 1" x 24"
15221	55-gal drum	PVC 1" x 28"
15222	275-gal drum	PVC 1" x 36"

5:1 Ratio Oil Pumps

Recommended For Delivery Of Oil Based Fluids & Antifreeze

PART# 1730R

Double Action 5:1 Stub Style Oil Pump
For dispensing fluid from various sized
containers by using a customized suction
tube (see chart below)

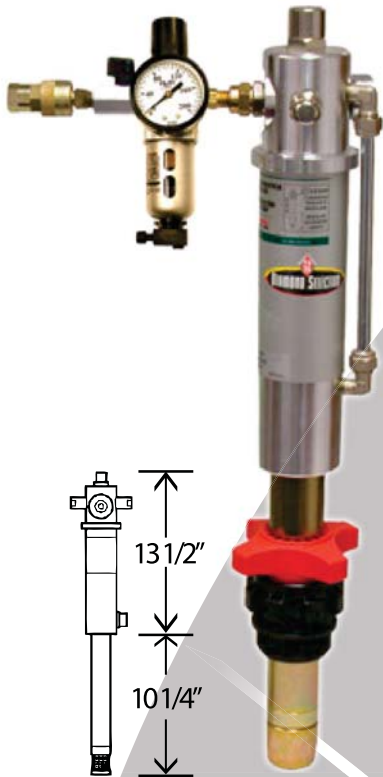

PART# 1745

5:1 Oil Pump Double Action
Fits 55-gallon drum
For dispensing high density oil
from both fixed and mobile
installations

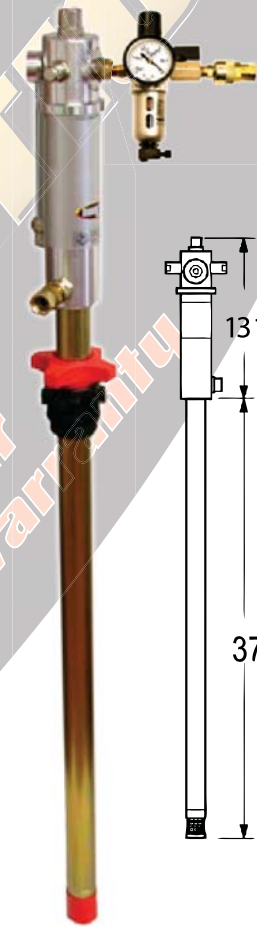

Optional Extensions (PVC):

Part#	Fits	Extension
15219	16-gal drum	PVC 1" x 24"
15221	55-gal drum	PVC 1" x 28"
15222	275-gal drum	PVC 1" x 36"

Specifications

Part #	1730R	1745
Max. Delivery	4.7 GPM (5:1 Ratio)	4.7 GPM (5:1 Ratio)
Max. Fluid Viscosity	240 SAE	240 SAE
Max. Fluid PSI	550 PSI	550 PSI
Max. Air PSI	110 PSI	110 PSI
Air Consumption	8.2 CFM @ 100 PSI	8.2 CFM @ 100 PSI
Air Inlet	1/4" NPT	1/4" NPT
Fluid Inlet	1" NPT	1" NPT
Fluid Outlet	1/2" NPT	1/2" NPT
Oil Hose	1/2" x 4-ft (2204)	1/2" x 4-ft (2204)
Air Hose	1/4" x 4-ft (2004)	1/4" x 4-ft (2004)
Pump Length	23 3/4"	50 1/2"
Foot Valve W/ Screen	KR3308	KR3309
Bung Adapter	38042	38042
Pressure Relief Valve	Optional (28625)	Optional (28625)
Air Line Filter Package	1559A-ASSY	1559A-ASSY

Optional Accessories

PART# 28625



Pressure relief valve

•Prevents damaging back pressure
on pumps, meters and reels. It is
highly recommended for this pump.

TOTE MOUNTING PLATE

& Tote Dispensing Systems
Recommended for Bulk Oil & Synthetic Oil

OIL

PART# 6601

Tote mounting plate



Features

- Fits totes 39" to 41" wide
- Clamps to side rails of most shaped cages
- Meter holder that catches oil droplets
- Steel construction
- 2" NPT threads for pump
- 2" filler neck with rubber cap
- Holes for mounting Zeeline reels

Tote Mounting Kits:

Part#	Pump	Reel / Hose	Meter	Pickup Tube
6611	3:1 Stub (1712)	32-ft. Reel (1475R)	Mechanical (1525)	P/N 15216
6612	3:1 Stub (1712)	32-ft. Reel (1475R)	Mechanical (1515)	P/N 15216
6613	3:1 Stub (1712)	25-ft. Hose (2225)	Digital (1504)	P/N 15216
6614	3:1 Stub (1712)	32-ft. Reel (1475R)	Digital (1504)	P/N 15216

Shipping Information

- ◇ 24-lbs.
- ◇ 7"x16"x45"

Portable Rollaround Units
Recommended For Bulk Oil & Synthetic Oil



PART# 5265



Features

- 17-gallon wheel-mounted tank
- 3:1 ratio pump (dispenses 3.7 GPM @ 90 PSI)
- Maximum air pressure 110 PSI
- Air consumption 12 CFM @ 100 PSI
- Digital meter (1504)
- Delivery hose (13-ft. length, 1/2" diameter)
- 3" front and 6" rear wheels with ball bearings
- Loading funnel features an anti-splash rim
- Level gauge

PART# 3024



Features

- 5-gallon wheel-mounted tank for modern workplaces
- No pump needed
- Maximum air pressure 100 PSI
- Delivery hose and control handle
- Loading funnel features an anti-splash rim
- Level gauge

ELECTRIC OIL PUMP

Features

- Easy access screen for simple maintenance
- Built in bypass valve and on/off switch
- Self-priming, positive displacement
- Air Cooled Motor W/Thermal protection

Specifications

Part #	936G	938G
Delivery Rate	4.4 GPM	8 GPM
Max Oil Viscosity	90-wt. @ 50°	90-wt. @ 50°
Inlet Port	1" NPT	1" NPT
Outlet Port	3/4" NPT	3/4" NPT
Discharge Hose	3/4" x 8-ft.	3/4" x 8-ft.
Suction Tube	3/4" PVC	3/4" PVC
Motor	115-Volt AV 1/2hp	115-Volt AV 1/2hp
Max Oil Temp	150°	150°
Max Outlet PSI	65 PSI	65 PSI
RPM	1725 RPM	3450 RPM

PART# 936G & 938G

For transferring oil, antifreeze & hydraulic fluid



OIL BARS

Metered & Non-Metered

Recommended For Dispensing Of Oil Based Fluids

OIL



NON - METERED



METERED

Features

- Anti-splash filter on oil tap
- Self closing oil tap (1608RNL)
- Easy to clean removable drip tray

Size

- ◇Height: 26 1/2"
- ◇Width: 22"
- ◇Depth: 17"

Recommended Optional Accessories

- Spigot kit for additional oil taps (16110R) (Includes 1608R Locking)
- Spigot and meter kit for additional oil taps and meter (16111R) (Includes 1608R Locking)



PART# 1608RNL
Non Locking Oil Tap



PART# HS1600



PART# 1504AR

PART# 1608R
Locking Oil Tap

Specifications

Part #	No. of Taps	No. of Meters	Meters P/N
1610R	1	None	
1620R	2	None	
1630R	3	None	
1615R	1	1	1504AR
1625R	2	2	1504AR
1635R	3	3	1504AR

WARNING: Do not use with flammable or corrosive material

PART# 1208

Includes Pint Meter (1500)



16-gallon Drum

PART# 1209RAR

Pump, Hose, & Nozzle Only



16 - 55-gallon Drum

PART# 1209

Pump Without Meter Package



16-gallon Drum

Features

- Double-Action pump
- Adjustable lever for varying oil viscosity
- First two holes near suction rod must be used for all lubes over 50-wt. Use last hole for maximum delivery
- Buna N Seals
- Plated carbon steel construction
- Steel telescoping suction tube
- Bung adapter

Specifications

Part #	1208	1208RAR	1209
Delivery	1-gal. per 32 strokes	1-gal. per 32 strokes	1-gal. per 32 strokes
Container Size	16-Gallon Drum	16 - 55-Gallon Drum	16-Gallon Drum
Discharge Hose	5-ft. Delivery Hose	5-ft. Delivery Hose	5-ft. Delivery Hose
Drum Cover	680-823	Not Included	680-823
Drum Dolly	120-S	Not Included	120-S
Meter	Pint Meter (1500)	Not Included	Not Included

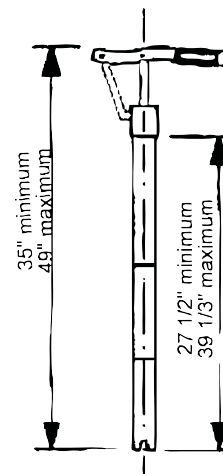

HAND PUMPS

Quart Stroke Hand Pump

Recommended for Oil Based Fluids & Gear Lube

OIL

WARNING: Not recommended for use with fuel, water based fluids, or other corrosive liquids

PART# 975

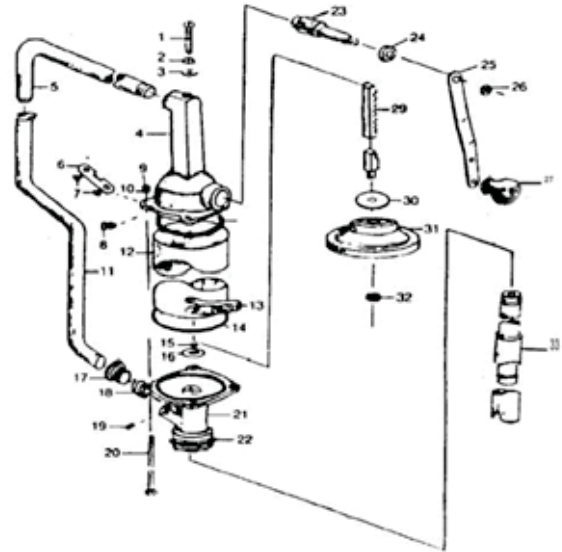

Specifications

Part #	975
Container Size	15 to 55-gallon
Bung Size	2" NPT
Delivery	1-quart per cycle
Lockable Crank Arm	Yes
Suction Tube	Steel Telescoping
Seals	Delrin

Ref. No.	Part No.	Description
1.	975-005	Adjustment Screw
2.	975-010	Jam Nut
3.	975-015	Leather Washer
4.	975-020	Top Casting
5.	975-025	Discharge Spout
6.	975-030	Rack Guide
7.	104025	Rack Guide Screws
8.	975-040	Dog Point Screw
9.	975-045	Main Stud Nuts
10.	104017	Main Stud Washers
11.	975-055	Drain Tube
12.	975-060	Cylinder
13.	975-065	Lock Pin
14.	975-070	Cylinder Gasket
15.	104012	Check Valve Screw
16.	975-080	Check Valve Washer
17.	975-085	Bushing
18.	975-090	Spring
19.	975-095	Set Screw
20.	975-100	Main Studs
21.	975-105	Bottom Casting
22.	104006	Locking Ring
23.	975-115	Pinion
24.	975-120	Pinion Seal
25.	975-125	Crank Arm
26.	975-130	Crank Locknut
27.	975-135	Crank Knob
28.	975-140	Crank Rivet
29.	975-145	Rack
30.	975-150	Piston Valve
31.	975-155	Piston
32.	975-160	Lock Nut
33.	L30-99N	Suction Tube

For 15 - 55 Gallon Drums

Recommended for Light Oil (Max 40 wt.), ATF, Hydraulic Fluid, Kerosene & Diesel Fuel

PART# 381

Variable Stroke



PART# 382

Variable Stroke
With non-drip tip



PART# D-S

Lever Pump



PART# D-S1

Lever Pump (D-S)
With non-drip attachment (D01)



IMPORTANT: Not suitable for water based products

Features (381 & 382)

- Steel construction with die cast aluminum head and base.

Features (D-S & D-S1)

- Rugged steel construction

PART# D01

Non-drip Attachment



Specifications

Part #	381	382	D-S	D-S1
Delivery Rate	1-gal. per 9 strokes	1-gal. per 9 strokes	1-gal. per 9 strokes	1-gal. per 9 strokes
Variable Stroke	Yes	Yes	Yes	Yes
Suction Tube	Telescoping PVC	Telescoping PVC	Telescoping PVC	Telescoping PVC
Non-Drip Tip	No	Yes	No	Yes (D01)
Powder Coat Finish	Yes	Yes	Yes	Yes
Seals	Buna N Seal	Buna N Seal	Buna N Seal	Buna N Seal
Theads on Spout	Garden Hose	N/A	Garden Hose	N/A

Optional Accessories

PART# 104006G

- Locking Nut Allows 360° positioning of pump
- Can be used on all pumps listed above



PART# 170

Lever Lock

- Fits most lever style drum pumps
- Fits up to 1/2" locks
- Lock not included



PART# L30-99N

Steel Telescoping suction tube with foot valve



HAND PUMPS

For Transferring And Dispensing

Recommended for Light Oils, ATF, and Hydraulic Oil

OIL

IMPORTANT! Not recommended for use with fuels, water based fluids or other corrosive liquids

PART# 101

Suction Gun



Features

- 17-oz. capacity
- 12" clear vinyl plastic hose
- Powder-coated steel construction
- Buna N piston ring

PART# 353

Plastic Bucket Pump

Attaches directly to pull-up spout on many 5-gal pails No need to remove sealed pail covers



Features

- Dispenses approx. 1-Qt. per 19 strokes
- Downstroke operation (*New Design*)
- Plastic pump head and steel tube
- Attaches directly to pull up spout creating tight fit without removing pail cover
- 48" long hose with embedded spring Discharge hose fitted with non drip tip (*New Design*)
- Metal curved pump spout
- Plastic pump extension for 6 1/2-gallon pail
- Includes 7 pump adapters for all types of pails

GEAR LUBE HAND PUMP

PART# 321

For dispensing oils, ATF & gear lube (max 140-wt.) from 5 - 6 1/2-gallon pails

Features

- Delivers approx. 1-gal per 55 strokes
- Variable stroke handle
- Powder coated pail cover
- 4-ft. vinyl hose with curved nozzle
- Buna N seal



HAND PUMPS

Lift Style For 15 - 55 Gallon Drums

Recommended for Light Oil (Max 40 wt.), ATF, Hydraulic Fluid, Kerosene & Diesel Fuel

IMPORTANT: Not suitable for water based products

PART# 366

Pumps light oil, kerosene and diesel Fuel from 15-55 gallon drums



PART# 366T

Pumps most types of paint thinners And some non-corrosive chemicals From 15-55-gallon drums



Features (366 & 366T)

- Plated steel construction with die cast aluminum head
- Heavy duty bar stock handle
- Cast iron bung adapter for a durable long lasting thread
- Garden hose threads on the head of the pump allow for threaded connection or a slip style connection on the 1/2" spout
- Brass piston rings for smooth operation without deterioration

Specifications

Part #	366	366T
Delivery Rate	1-gal. per 6 lift strokes	1-gal. per 6 lift strokes
Container Size	15-55-gallon drums	15-55-gallon drums
Length	37 1/2"	37 1/2"
Seal	PTFE	PTFE
Bung Adapter	Powder Coated	Unpainted

HAND PUMPS

OIL

Lever Style Pumps

Recommended for Oil & Gear Lube (Maximum 140 wt.)

IMPORTANT! Not recommended for use with fuels, water based fluids or other corrosive liquids

PART# 155

Lever Style Pump
For 30 to 55-gallon drums



PART# 336

Gear Lube Pump
For 16-gallon open head drums



PART# 15-30

Lever Style Pump
For 15 to 30-gallon drums



PART# 338

Lever Style Pump
For 15 to 55-gallon drums



Specifications

Part #	Hose Assembly	Bung Adapter	Delivery (Approx.)	Seals
155	5-ft. (104016-A)	2" (106025)	1-gal per 32 strokes	Buna N
15-30	5-ft. (104016-A)	2" (106025)	1-gal per 32 strokes	Buna N
336	5-ft. (104016-A)	Cover for Drum	1-gal per 32 strokes	Buna N
338	None	2" (106025)	1-gal per 32 strokes	Buna N

OIL

WASTE OIL DRAINS

For Gravity Drain Of Oil Based Fluids

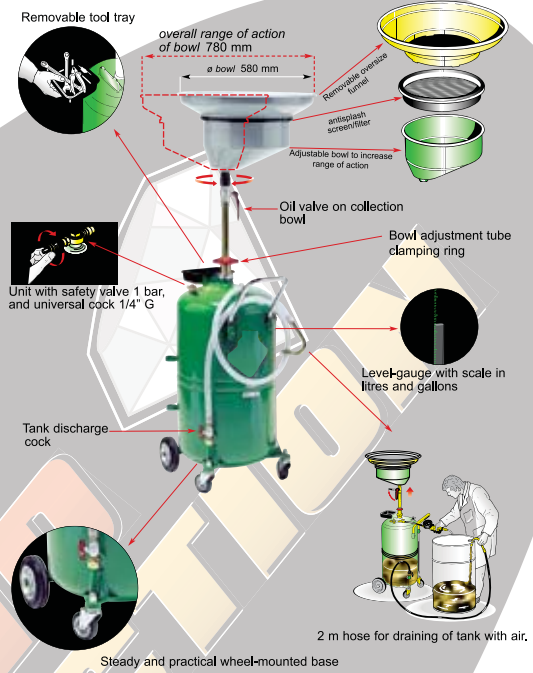

PART# 1235

- 17-gallon wheel mounted tank
- Adjustable height with minimum 49" and maximum 69"

PART# 1236

- 23-gallon wheel mounted tank
- Adjustable height with minimum 55" and maximum 75"

Features

- Centrally mounted bowl on swivel joint for positioning
- Front and rear ball bearing wheels (3" front casters and 6" rear wheels)
- Level sight gauge: scale in litres and gallons
- Anti-splash screen/filter provides useful support for draining used filters

Specifications

Part #	1235	1236
Collection Capacity	13.7-gallons (Max)	19.7-gallons (Max)
Funnel	22 1/2" diameter	22 1/2" diameter
Bowl	3 1/2-gallon adj. height	3 1/2-gallon adj. height
Draining PSI	7 PSI (Max)	7 PSI (Max)
Drain Hose	6 1/2-ft	6 1/2-ft
Tool Tray	6" x 8" x 2" Steel	6" x 8" x 2" Steel

OIL EVACUATION UNITS

For Removing Hot Engine Oil In Hard To Access Areas

OIL



PART# 1230

•23-gallon Portable Unit



PART# 1231

•23-gallon Portable Unit With Funnel

Features

- 2 heavy-duty 6" ball bearing rear wheels
- 2 front 3" ball bearing swivel casters
- Fluid level indicator
- Continuous connection to air source not required
- Probes size and type:

Plastic	1/4" x 27 1/2"	Metal	1/4" x 27 1/2"
	3/16" x 27 1/2"		3/16" x 27 1/2"
	5/16" x 27 1/2"		
	9/32" x 39 3/8"		

Specifications

Part #	1230	1231
Tank Capacity	23-gallon	23-gallon
Min. Oil Temp	158° F (For suction)	158° F (For suction)
Draining PSI	7 PSI (Max)	7 PSI (Max)
Suction Hose	6 1/2-ft w/ Probes	6 1/2-ft w/ Probes
Drain Hose	6 1/2-ft	6 1/2-ft
Tool Tray	6" x 8" x 2" Steel	6" x 8" x 2" Steel



X IMPORTANT! DO NOT drain brake fluids, fuels or any flammable or corrosive liquid

OIL

WASTE OIL DRAINS

30 - Gallon Pantograph Waste Oil Suction / Drainer

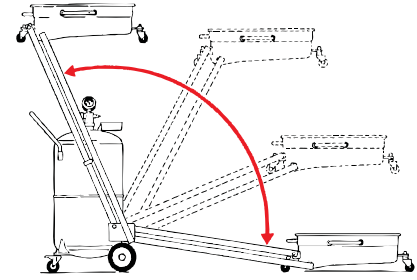

The pantograph arms allow the tank to be placed on the floor or raised, for draining under a lift.

Overall dimensions

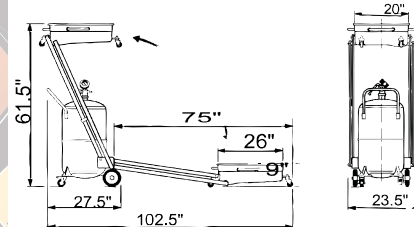

PART# 6215

Drains oil from heavy-duty trucks and RVs where a lift drain is not safely available

Features

- This versatile 3 in 1 oil suction/drafter can be used to change oil on all types of automobiles and trucks:
 - 1) By gravity with tank on floor
 - 2) By gravity with tank raised, with motor vehicles placed on auto lift or over a pit
 - 3) By suction with probe inserted directly in the engine. A continuous connection to the compressed air line or other energy source is not required (the oil must be hot 160 - 175° F)
- 30-gallon wheel mounted tank holds 25-gallons before draining
- Tank is equipped with level gauge and removable tool tray
- 13-gallon drain pan can be lowered to a 9" height for rolling under cars and trucks

X IMPORTANT! DO NOT drain brake fluids, fuels or any flammable or corrosive liquid

WASTE OIL DRAINS

For Gravity Drain Of Oil Based Fluids & Antifreeze

OIL

PART# 1234

For gravity drain of fluids from engines, gearboxes or differentials of all motor vehicles placed on an auto-lift or pit

Features

- Adjustable waste oil drain with minimum height 53" and maximum height 65"
- 21-gallon wheel mounted tank with front ball bearing wheels
- Centrally mounted bowl on swivel joint for positioning
- Level sight gauge: Scale in liters and gallons
- Anti-splash screen/filter provides useful support for draining used filters
- 6" x 8" x 2" removable steel tool tray

Specifications

Part #	1234
Collection Capacity	16-gallons (Max)
Funnel	14" diameter
Bowl	4-gallon adj. height
Draining PSI	7 PSI (Max)
Drain Hose	6 1/2-ft
Tool Tray	6" x 8" x 2" Steel



PART# 309,316,318

Features

- Translucent
- Durable polyethylene construction
- 18" polyethylene funnel (699J)
- 1 3/4" drain tube
- Adjusts from 44 1/2" to 67" in height

Optional Accessories

- Drain Pan 24" x 24" (776)
- Drain Pan 24" x 37" (778)

Part #	Capacity	Casters	Drain Valve	2"NPT Opening
309	8-Gallon	No	No	No
316	8-Gallon	Yes	No	No
318	18-Gallon	Yes (3 1/2")	Yes	Yes



PART# 318



PART# 312

PART# 312

For converting 120 lb. open head drum into a lift drain ****Drum not included****

Features

- Fits 16-gallon or 120-lb. open head containers
- Drum cover
- 67 1/2" drain pipe
- 14" steel funnel

Optional Accessory

- Drum dolly (120-S)

TRUCK OIL DRAINS

For Draining Fluids Where A Lift Drain Is Not Suitable
 Recommended For Oil Based Fluids & Antifreeze



PART# 237
Truck Drain



PART# 236
Evacuation Kit

PART# 237

For draining oil or antifreeze from heavy-duty trucks and RVs where a lift drain is not suitable

Note: Ships freight only, 55lb. shipping weight.

Features

- 17-gallon capacity
- Translucent body for easy viewing of fluid level
- Heavy-duty polyethylene
- Wire screen
- 2 rear stationary wheels for stability
- 2 large swivel casters

Part #	237	234
Capacity	17-gallons (Max)	17-gallons (Max)
Dimensions	8"H X 25" W X 46" L	8"H X 25" W X 46" L
Pump	115V (4 GPM)	Not Included
Hose	6-ft Rubber Hose	Not Included

PART# 234

Same as 237 Without pump or hose

Note: Ships freight only, 50lb. shipping weight.

PART# 236

Evacuation Kit with fittings, pump & hose only



PART# 227
Truck Drain

PART# 227

For draining oil or antifreeze from heavy-duty trucks and RVs where a lift drain is not suitable

Note: Ships freight only, 49lb. shipping weight.

Features

- 18-gallon capacity
- 8" height x 25 1/2" width x 47 1/4" length
- Heavy-duty steel construction
- 1/2" NPT drain outlet



PART# 1035K2
Air operated suction kit for draining Part# 227

PART# 1035K2

Evacuation Kit See Pg. 4

PNEUMATIC GREASE SYSTEM

GREASE

50:1 Ratio Pump For 25-50lb. Pail

Recommended For Grease Up To NLGI No. 2

PART# 3574R

Stationary Style / Fits 25-50-lb. pail
(Pail not included)



Specifications

Part #	3574R
Pump	Heavy-Duty 50:1 Ratio
Max Grease NLGI	No. 2
Max. Delivery	52 oz per minute @ 90PSI
Max. Air PSI	110 PSI
Air Consumption	4.59 CFM @ 100 PSI
Air Inlet	1/4" NPT
Air Hose	1/4" x 4-ft (2004)
Tube Length	16"
Pump Tube Diameter	1 3/16"
Air Line Filter Package	1559A-ASSY

- Systems with dispensing hose length other than specified above are also available as shown in the chart below

Part #	Hose Length	Hose P/N
3574R	6-ft.	1806
3574R-00	None	
3574R-10	10-ft.	1810
3574R-12	12-ft.	1812
3574R-16	16-ft.	1816
3574R-20	20-ft.	1820
3574R-25	25-ft.	1825

Included Accessories



Regulator
Combination Unit
1559A-ASSY

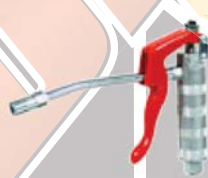

Control Handle
1536A



Carry Handle
66599



Air Hose
2004



Drum Cover
65310



"Z" Swivel
1545



Follower Plate
107016



Grease Hose
1806



Complete system with all parts shown for pumping grease from 25-50lb. pails



PNEUMATIC GREASE SYSTEM

60:1 Ratio Pump For 25-50lb. Pail

Recommended For Grease Up To NLGI No. 2

PART# 3574A

Stationary Style
Fits 35-50-lb. pail

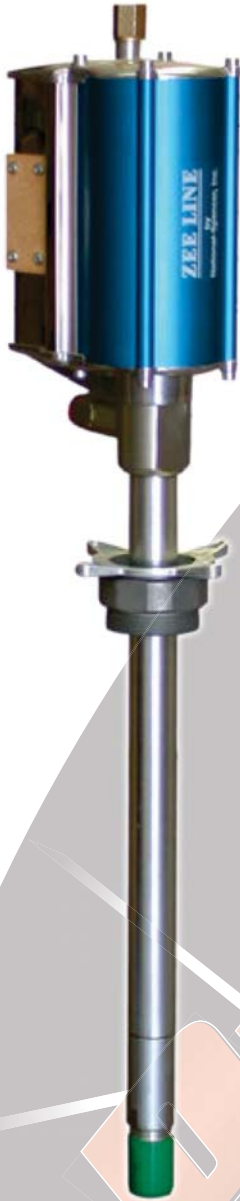

Specifications

Part #	3574A
Pump	Heavy-Duty 60:1 Ratio
Max Grease NLGI	No. 2
Max. Delivery	2.2-lbs per minute @ 100PSI
Max. Air PSI	100 PSI
Air Consumption	5.50 CFM @ 100 PSI
Air Inlet	1/4" NPT
Air Hose	1/4" x 4-ft (2004)
Tube Length	17 3/4"
Pump Tube Diameter	1 5/32"
Bung Adapter	2" (28591)
Air Line Filter Package	1559A-ASSY

- Systems with dispensing hose length other than specified above are also available as shown in the chart below

Part #	Hose Length	Hose P/N
3574A	6-ft.	1806
3574A-10	10-ft.	1810
3574A-12	12-ft.	1812
3574A-16	16-ft.	1816
3574A-20	20-ft.	1820
3574A-25	25-ft.	1825

Included Accessories

Complete system with all parts shown for pumping grease from 25-50lb. pails

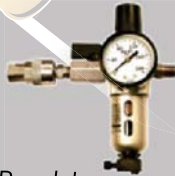

Regulator
Combination Unit
1559A-ASSY



Control Handle
1536A



Follower Plate
107016



Drum Cover
18527



Air Hose
2004



Grease Hose
1806



"Z" Swivel
1545



PNEUMATIC GREASE SYSTEM

GREASE

65:1 Ratio Pump For 120-lb. Drum

Recommended For Grease Up To NLGI No. 3

PART# 1213R

Portable Style
Fits 120-lb. Drum

Features

- Suction tube constructed with no seals to eliminate excessive wear

Specifications

Part #	1213R
Pump	Heavy-Duty 65:1 Ratio
Max Grease NLGI	No. 3
Max. Delivery	66-oz per minute @ 90PSI
Max. Air PSI	110 PSI
Air Consumption	8.74 CFM @ 100 PSI
Air Inlet	1/4" NPT
Air Hose	1/4" x 4-ft (2004)
Pump Head Dia.	2 1/2"
Head Length	10"
Tube Length	29"
Pump Tube Diameter	1 3/16"
Air Line Filter Package	1559A-ASSY



Complete system with all parts shown for pumping grease from 120-lb. drums

Application

- For dispensing most greases short and long distances
- Particularly suitable for centralized dispensing systems
- Highly recommended for specific needs requiring a higher quantity of grease and higher pressure

Included Accessories



Regulator
Combination Unit
1559A-ASSY



Control Handle
1536A



"Z" Swivel
1545



Drum Dolly
120-S



Drum Cover
65385



Follower Plate
1524



Grease Hose
1806



Air Hose
2004

- Systems with dispensing hose length other than specified above are also available as shown in the chart below

Part #	Hose Length	Hose P/N
1213R	6-ft.	1806
1213R-00	None	
1213R-10	10-ft.	1810
1213R-12	12-ft.	1812
1213R-16	16-ft.	1816
1213R-25	25-ft.	1825
1213R-50	50-ft.	1850

PNEUMATIC GREASE SYSTEM

50:1 Ratio Pump For 120-lb. Drum

Recommended For Grease Up To NLGI No. 2



PART# 1220R

Portable Style
Fits 120-lb. Drum

Features

- Suction tube constructed with no seals to eliminate excessive wear

Specifications

Part #	1220R
Pump	Heavy-Duty 50:1 Ratio
Max Grease NLGI	No.2
Max. Delivery	52-oz per minute @ 90PSI
Max. Air PSI	110 PSI
Air Consumption	4.59 CFM @ 100 PSI
Air Inlet	1/4" NPT
Air Hose	1/4" x 4-ft (2004)
Pump Head Dia.	2 1/2"
Head Length	10"
Tube Length	29"
Pump Tube Diameter	1 3/16"
Air Line Filter Package	1559A-ASSY

- Different systems with dispensing hose length are also available as shown in the chart below

Part #	Hose Length	Hose P/N
1220R	6-ft.	1806
1220R-12	12-ft.	1812
1220R-16	16-ft.	1816

Included Accessories



Regulator
Combination Unit
1559A-ASSY



Control Handle
1536A



"Z" Swivel
1545



Drum Dolly
120-S



Drum Cover
65385



Follower Plate
1524



Grease Hose
1806



Air Hose
2004

Complete system with all parts shown for pumping grease from 120-lb. drums



PNEUMATIC GREASE SYSTEM

GREASE

60:1 Ratio Pump For 120-lb. Drum

Recommended For Grease Up To NLGI No. 2

PART# 1213A & 1214A

Portable Style, Fits 120-lb. Drum

Specifications

Part #	1213A & 1214A
Pump	Heavy-Duty 60:1 Ratio
Max Grease NLGI	No. 2
Max. Delivery	2.2-lbs per minute @ 100PSI
Max. Air PSI	100 PSI
Air Consumption	5.50 CFM @ 100 PSI
Air Inlet	1/4" NPT
Air Hose	1/4" x 4-ft (2004)
Tube Length	29 1/2"
Pump Tube Diameter	1 5/32"
Bung Adapter	2" (28591)
Air Line Filter Package	1559A-ASSY



- Different systems with dispensing hose length are also available as shown in the chart below

Complete system with all parts shown for pumping grease from 120-lb. drums

Part #	Hose Length	Hose P/N
1213A	6-ft.	1806
1213A-00	None	
1213A-10	10-ft.	1810
1213A-12	12-ft.	1812
1213A-16	16-ft.	1816
1213A-25	25-ft.	1825
1213A-50	50-ft.	1850

Part# 1213A Included Accessories



Regulator
Combination Unit
1559A-ASSY

Control Handle
1536A

"Z" Swivel
1545

Drum Dolly
120-S

Drum Cover
680-823

Follower Plate
1524

Grease Hose
1806

Air Hose
2004

Part# 1214A Included Accessories



Regulator
Combination Unit
1559A-ASSY

Follower Plate
1524

Grease Hose
1806

Air Hose
2004

Drum Cover
680-823

PART# 1212R

Dispenses Grease From 400-lb. Open Head Drum

Features

- Durable steel pump head
- Air motor with silicon lube to eliminate the need for an oiler

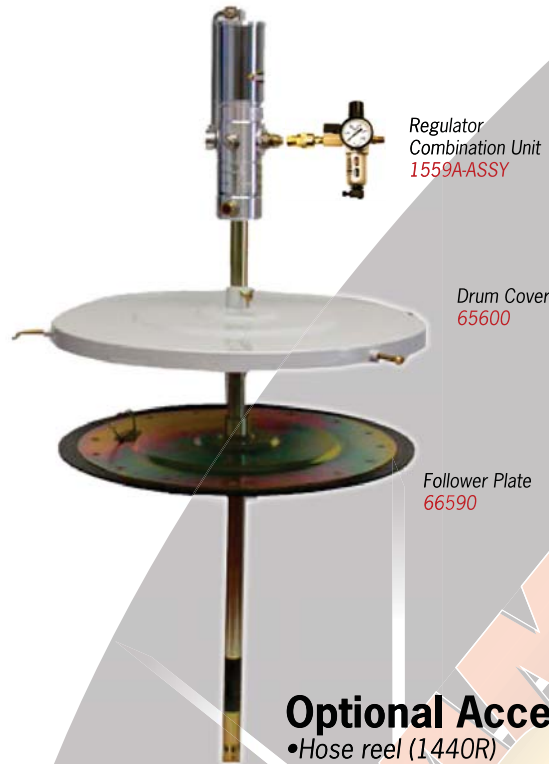

Regulator
Combination Unit
1559A-ASSY

Drum Cover
65600

Follower Plate
66590

PART# 1212A

Stationary Style, Fits 400-lb. Drum



Regulator
Combination Unit
1559A-ASSY

Drum Cover
18525

Follower Plate
18573

Air Hose
2004

Grease Hose
1804

Optional Accessories

- Hose reel (1440R)
- Booster control handle (1536A)
- "Z" Swivel for use with 1536A control handle (1545)
- Continuous flow control handle (1534)
- "Z" swivel for use with 1534 control handle (1547)
- Drum dolly (140-S, 140-SOR)

Specifications

Part #	1212R	1212A
Pump	Heavy-Duty 65:1 Ratio	Heavy-Duty 60:1 Ratio
Max Grease NLGI	No. 3	No. 2
Max. Delivery	66-oz per minute @ 90PSI	2.2-lbs per minute @ 100PSI
Max. Air PSI	110 PSI	110 PSI
Air Consumption	8.47 CFM @ 100 PSI	5.50 CFM @ 100 PSI
Air Inlet	1/4" NPT	1/4" NPT
Air Hose	1/4" x 4-ft (2004)	1/4" x 4-ft (2004)
Grease Hose	1/4" x 4-ft (1804)	1/4" x 4-ft (1804)
Tube Length	37"	36 5/8"
Pump Tube Diameter	1 3/16"	1 5/32"
Bung Adapter	N/A	2" NPT (28591)
Air Line Filter Package	1559A-ASSY	1559A-ASSY

GREASE HANDLES

GREASE

Continuous Flow & Booster Control Handles

Recommended For Dispensing Grease From Air Operated Pumps

PART# 1534

Continuous Flow Handle



Features

- Pressure is determined by the pump used with this handle

Available Options

- "Z" swivel 1/4" F NPT Inlet, 1/4" M NPT outlet (1547)
- Straight swivel 1/4" F NPT Inlet, 1/4" M NPT outlet (1544)



PART# 1533

Booster Handle With Pressure Relief Valve

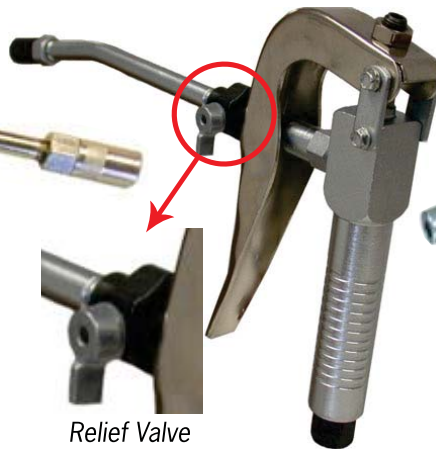

Relief Valve

Features

- Each pull of the handle increases pressure to a maximum 10,000 PSI

PART# 17

Flexible hose assembly for use with control handles



Features

- Includes adapter, hose and coupler
- Working pressure 5000-PSI
- Burst pressure 20,000-PSI

PART# 1536A

Booster Handle

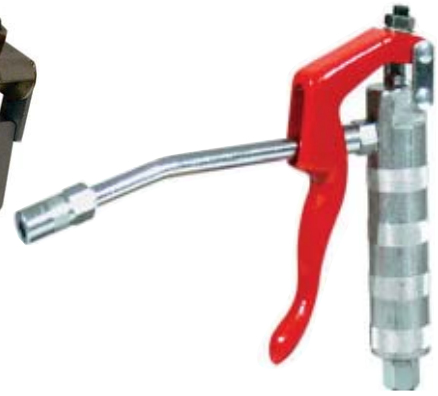

Features

- Each pull of the handle increases pressure to a maximum 10,000 PSI

Available Options

- "Z" swivel 1/4" F NPT Inlet, 1/8" M NPT outlet (1545)



Specifications

Part #	1533	1534	1536A
Inlet	1/8" NPT	1/4" NPT	1/8" NPT
Outlet	1/8" NPT	1/8" NPT	1/8" NPT
Continuous Flow	Yes	Yes	Yes
Grease Coupler	N/A	Standard 3-Jaw (28)	Heavy-Duty 3-Jaw (25)
Pressure Relief Valve	Yes	No	No
Construction	Steel	Steel	Aluminum

Steel follower plates suitable for barrels, drums and pails (straight or tapered).



107012 / 107016



1524

Specifications

Part #	Description	Ideal For	I.D	O.D
For 25-50-lb. Pails				
107012	Flexible Rubber Edge	328 (page 45)	1.50"	11.25"
107014	Flexible Rubber Edge		1.19"	11.25"
107016	Flexible Rubber Edge	3574A (page 36) 3574R (Page 37)	1.16"	11.375"
230000	1/ 1/4" Center Rubber Gromment	567 (page 43)	1.25"	11.00"
For 120-lb. Drums				
1523	Flexible Rubber Edge	327 (page 45)	1.437"	14.25"
1524	Flexible Rubber Edge	1213R (page 37) 1220R (Page 38) 1213A (Page 39)	1.25"	15.00"
For 400-lb. Drums				
18573	Flexible Rubber Edge	1212A (page 40)	1.175"	23.25"
66590	Flexible Rubber Edge	1212R (page 40)	1.25"	23.25"



1523



18573

HAND GREASE PUMPS

For Dispensing Grease From 25 To 50-lb. Pails

Recommended For Grease Up To NLGI No. 2

GREASE

PART# 550

NEW
IMPROVED DESIGN



Features

- Maximum output pressure 3500 PSI
- Delivers 1.2-oz. per 28 strokes
- 4 jaw coupler
- Follower plate (107016)
- 6-ft. high pressure hose
- Carrying handle
- Fits 25 to 50-lb. pail
- Easily dispenses to a grease fitting

PART# 567



Manual grease dispensing system including spring loaded pump, booster control handle, follower plate, and connecting hose. When installed on a 25-50 lb. pail (not included), each downstroke of the pump handle allows up to 3.2 oz. of grease to be dispensed through the booster handle.

The booster handle is a single shot style and includes connecting hose, swivel, and a switch for high volume or high pressure.

Features

- Maximum output pressure 8000 PSI
- Booster control handle
- Follower plate (107016)
- 9-ft. low pressure hose
- Fits 25 to 50-lb. pail (pail not included)

PART# 540



Features

- Variable stroke develops up to 4000 PSI
- Delivers 0.3-oz. per stroke
- 22-lb. steel container with carrying handle
- Heavy duty cast iron pump
- 6 1/2-ft. high pressure hose with 4 jaw coupler
- Spring loaded follower plate
- Container must be used with this pump and bulk filled
- Recommended for grease up to NLGI No. 3

PART# 625

Bench Type (Max Bearing Size 6")

For use with hand or pneumatic grease gun



Features

- Non-threaded top cone for fast placement of bearings
- Dust cover
- Mounting base

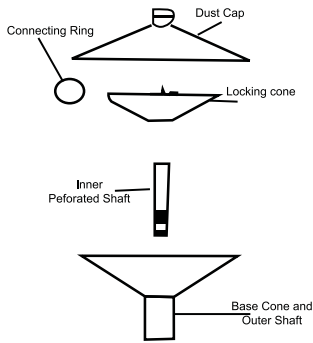

PART# 333

Grease Pump and Bearing Packer For 25 To 50-lb. Container



PART# 343

Grease Pump and Bearing Packer For 120-lb. Container



Specifications

Part #	333	343
Delivery	Variable Stroke up to 1-oz per stroke	Variable Stroke up to 1-oz per stroke
Follower Plate	107012	1523 (Replacement)
Pump Construction	Zinc Plated	Zinc Plated
Head Construction	Zinc Die Cast	Zinc Die Cast
Pump Length	18"	30"
Drum Cover Diameter	12" Powder Coated	16" Powder Coated
Collar	Adjustable	Adjustable

PART# 331

Portable Bearing Packer with Grease Gun



Features

- Non-threaded top cone for fast placement of bearings
- Dust cover
- Extended base
- Portable
- Gun holder (149SP)
- Lever style grease gun (419)

GREASE GUN FILLER PUMPS

GREASE

For Filling From Drums & Pails

Recommended For Grease Guns With Male Loader Fittings

PART# 327

For 120-lb. Drum

Pump length 30"
Drum cover diameter 16"



PART# 328

For 25-50-lb. Drum

Pump length 18"
Drum cover diameter 12"
"Rubber lined follower plate"



Specifications

Part #	327 & 328
Delivery	Variable Stroke up to 1-oz per stroke
Follower Plate	327(*1523) 328(107012)
Pump Construction	Zinc Plated
Head Construction	Die-cast Aluminum
Flange Construction	Cast Aluminum
Male Loader Nipple	80SP
Female Loader Nipple	29

*Replacement follower plate

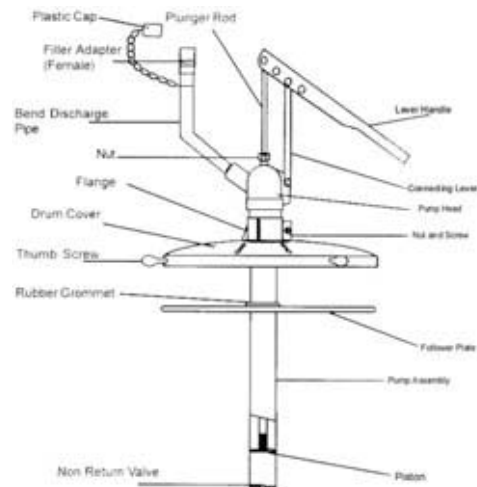

GREASE

CORDLESS GREASE GUN

19.2 Volt Grease Gun & Charger

Recommended For Grease Up To NLGI No. 2 At Minimum Of 50°

NEW
LITHIUM GREASE GUN



PART# 912-19 & 912-19L

19.2-volt Cordless Grease Gun
(NiCad or Lithium)

For delivery of grease in a variety of applications & hard to reach areas



Specifications

Part #	912-19 (NiCad)	912-19L (Lithium)
Max PSI	8500 PSI	8500 PSI
Battery Pack	(2) 1500mAh (91201-19) (1lb 11oz.)	(1) 19.2v Lithium (91201-19L) (13.5oz.)
Hose	30" Whip Hose w/spring guard	30" Whip Hose w/spring guard
Capacity	14 1/2-oz. Cartridge	14 1/2-oz. Cartridge
Threads	1/8" NPT	1/8" NPT
Charger	1-hr. Charger (91202-19)	1-hr. Charger (91202-19L)
Loading Options	Cartridge, Suction, or Bulk	Cartridge, Suction, or Bulk
Air Bleeder Valve	Yes	Yes
Shoulder Strap	91207-19	91207-19
Storage Case	Hard Plastic	Hard Plastic

NEW
LITHIUM BATTERY KIT

PART# 912-19LK

19.2-volt NiCad to Lithium Retro Fit Kit

Convert all National -Spencer 912-19 NiCad grease guns to the NEW 19.2v lithium grease gun.

Lithium Has 30% More Power Than NiCad



PART# 91201-19L



PART# 91202-19L

****WARNING DO NOT MIX BATTERIES AND CHARGERS. ONLY USE NICAD WITH NICAD AND LITHIUM WITH LITHIUM****

Optional Accessories

- 12-Volt Car Charger (91203-19)
- Grease Tube Blanket Warmer (91204-19)



PNEUMATIC GREASE GUNS

GREASE

Pistol Style Grease Guns

Recommended For Grease Up To NLGI No. 2

PART# 911

Single shot

Pistol Style Grease Gun

PART# 914

Continuous Flow

Pistol Style Grease Gun

Specifications

Part #	911 & 914
Max Outlet Pressure	4,000 PSI (40:1)
Delivery	1.30-oz per 40 shots
Inlet Pressure	75 to 100 PSI
Air Inlet	1/4" NPT
Capacity	14 1/2-oz. Cartridge
Extension	6" Steel (1/8" NPT)
Loading Options	Cartridge, Suction, or Bulk
Construction	Aluminum Die Cast Head

- Swivel male quick connect fitting (911 only)



GREASE FEEDERS

NEW

Grease Feeders are used to provide single point controlled lubrication for all types of bearing housings thereby eliminating difficulties arising due to over or under greasing.



Eliminates Over & under greasing resulting in fewer bearing failures!

Specifications

Part #	47721	47722	47724	47725
Bowl Capacity	2 oz.	6 oz.	2 oz.	6 oz.
Operating Condition	Static	Static	Dynamic	Dynamic
Overall Diameter	2.375"	3"	2.375"	3"
Overall Height	4.625"	6"	4.625"	6"
Bowl	Polycarbonate	Polycarbonate	Polycarbonate	Polycarbonate
Base	Polycarbonate	Polycarbonate	Aluminum	Aluminum

PART# 180

Zinc plated grease gun with rigid extension for 3-oz. grease cartridges



Features

- Single handed operation
- T grip plunger rod handle for firm grip
- Attractive clamshell packaging

Specifications

Part #	180 & 180G
Max Outlet Pressure	3,000 PSI
Coupler	4 Jaw w/Ball Check
Capacity	3-oz. Cartridge
Extension	4" Steel (1/8" NPT)
Loading Options	Cartridge or Suction
Construction	Textured Zinc Plated

PART# 180G

180 grease gun with (1) 3-oz. grease starter cartridge included.



Incorporates two discharge ports - front discharge port for regular greasing applications and top port for lubrication of hard to reach fittings.

Optional Accessories

- 12" flexible whip hose with 3-jaw coupler (P/N 16)
- Bag of (3) 3-oz. tubes lithium grease (P/N 35)



NLGI GRADES

NLGI Grade	Worked Penetration After 60 Strokes At 25 °c(0.1mm)	Appearance	Food Consistency Comparison
000	445-475	Fluid	Ketchup
00	400-430	Fluid	Applesauce
0	355-385	Very Soft	Brown Mustard
1	310-340	Soft	Tomato Paste
2	265-295	Moderately Soft	Peanut Butter
3	220-250	Semi-fluid	Vegetable Shortening
4	175-205	Semi-hard	Frozen Yogurt
5	130-160	Hard	Smooth Pate
6	85-115	Very Hard	Cheddar Cheese Spread

Zinc Plated And Powder Coated Pistol Grip Grease Guns

Recommended For Grease Up To NLGI No. 2

PART# 610

Zinc plated barrel
4" steel extension (P/N 59004)



PART# 619

Powder coated barrel
4" steel extension (P/N 59004)



PART# 613

Zinc plated barrel
12" whip hose (P/N 12R)



PART# 620

Powder coated barrel
12" whip hose (P/N 12R)



Features

- Comfortable one-hand operation
- Air release achieved through half turn of the head assembly

Specifications

Part #	All Models
Max Outlet Pressure	5,000 PSI
Delivery	1-oz. per 40 Strokes
Coupler	4 Jaw (27)
Capacity	14 1/2-oz. Cartridge
Threads	1/8" NPT
Loading Options	Cartridge, Suction or Bulk
Loading Nipple	Optional (8OSP)

Pistol Grip Grease Guns

Recommended For Grease Up To NLGI No. 3



PART# 609

Adjustable stroke grease gun with 18" whip hose & coupler

Features

- Adjustable Stroke (High Pressure / High Volume)
- Quick-load threadless barrel
- Powder coated barrel
- Maximum pressure 7000 PSI
- Delivers 1-oz. per 31 strokes
- Capacity 14 1/2-oz.
- Multiple loading options (cartridge, suction or bulk)

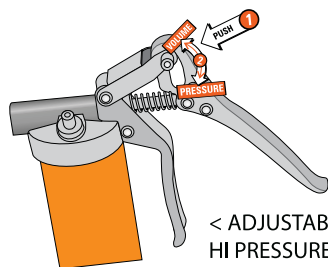

Threadless Quick Load barrel



PART# 615

Chrome plated barrel with dual grease outlets and 4" steel extension

Features

- Maximum pressure 5000 PSI
- Delivers 1 1/2-oz. per 40 strokes
- Chrome plated
- Rigid pipe (1/8" NPT)
- Capacity 14 1/2-oz.
- 2 grease outlets
- Multiple loading options (cartridge, suction or bulk)
- Attractive retail packaging

Optional Accessories

- Grease gun holder (149SP)
- Loader nipple (80SP)
- Flex grease hose (12R)
- 14 1/2oz. grease cartridge (33)



PART# 414

Die cast aluminum head.
Chrome plated finish with
5 1/2" steel extension and
12" flexible whip hose



PART# 415

Die cast aluminum head.
Chrome plated finish with
5 1/2" steel extension



PART# 444

Die cast aluminum head.
Powder coated finish with 5 1/2"
steel extension



Optional Accessories

- Grease gun holder (149SP)
- Loader nipple (80SP)
- Grease tube (33)
- Whip hose (12R)

Specifications

Part #	All Models
Max Outlet Pressure	7,000 PSI
Delivery	1-oz. per 28 Strokes
Coupler	4 Jaw (27)
Capacity	14 1/2-oz. Cartridge
Threads	1/8" NPT
Loading Options	Cartridge, Suction or Bulk

PART# 410

Zinc plated barrel
5 1/2" steel extension (55)
Rubber grip



PART# 413

Zinc plated barrel
12" flexible whip hose (12R)
Rubber grip



NEW
IMPROVED GRIP

PART# 419

Red powder coated finish
5 1/2" steel extension (55)



PART# 420

Red powder coated finish
5 1/2" steel extension (55) and
12" flexible whip hose (12R)



Features

- Air release through half turn of head assembly

Specifications

Part #	All Models
Max Outlet Pressure	7,000 PSI
Delivery	1-oz. per 28 Strokes
Coupler	4 Jaw (27)
Capacity	14 1/2-oz. Cartridge
Threads	1/8" NPT
Loading Options	Cartridge, Suction or Bulk

Premium Variable Stroke Lever Style Grease Guns

Recommended For Grease Up To NLGI No. 2

Premium 10,000 PSI Variable Stroke Grease Gun

PART# HD4

With 6" Steel extension 1/8" NPT (55)



Features

- Maximum pressure 10,000 PSI
- Delivers 1-oz. per 28 strokes
- Powder coated
- Holds 14 1/2-oz. cartridge
- Hydraulic Coupler (P/N 27)
- Loader nipple (P/N 80)
- Short stroke for ease of use in confined areas
- Heavy-duty head incorporates a bulk loader
- Multiple loading options (cartridge, suction or bulk)
- Soft rubber grip on lever handle for comfortable operation

PART# HD4A

With 12" flexible whip hose (12R)



Optional Accessories

- Grease Gun Holder (149SP)
- Premium Grease Cartridge (33)

PART# 149 & 149SP

Grease Gun Holder



PART# 159

Extra secure grease gun mount

Features

- Ideal for truck mounting
- Easy one hand operation



Quick Coupler Lube Kit

Recommended For Hand Operated Grease Equipment

PART# 660

Quick Coupler Lube Kit

For efficient connection and replacement of hand operated grease gun tips

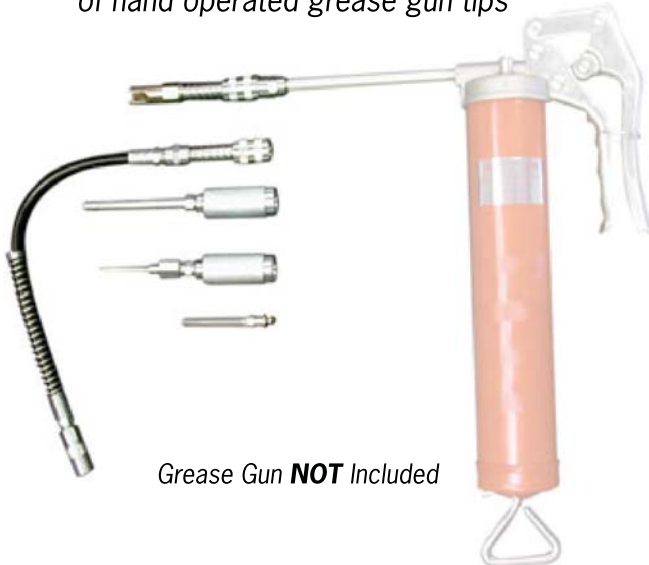

Grease Gun **NOT** Included



Retail Box



Features

- Quick connects are included with all tools
- Stainless steel needle 1 1/2" long
- Lube adapter, 90° angle
- Needle nose adapter with .046 diameter tip
- Professional recessed lube adapter 3 1/4" long
- Quick connect 12" hose with coupler and spring guard
- Attractive and durable nylon pouch

Application

- Where more than one grease gun coupler is needed
- Eliminates the need for multiple grease guns
- Saves time changing tips

PART# 186

Hand Operated Grease Fitting Cleaner
For unstopping clogged grease fittings



Features

- Plated steel finish
- Steel body
- 4-Jaw Grease Coupler (P/N 27)
- Includes 5" flexible hose
- Opens clogged grease fittings
- Replaceable O-Ring
- Skin packaged



With Clear Grease Tubes

Clear Barrel Allows For Easy Identification Of Grease Type

PART# 620CTB

With 12" flexible whip hose

Features

- Maximum pressure 5000-PSI
- Delivers 1-oz. per 40 strokes

Available Colors

- Silver (620CTS)
- Gold (620CTY)
- Purple (620CTP)
- Blue (620CTB)
- Black (620CTK)
- Red (620CTR)
- Green (620CTG)



PART# HD4ACTB

With 12" flexible whip hose

Features

- Maximum pressure 10,000 PSI
- Delivers 1-oz. per 28 strokes

Available Colors

- Silver (HD4ACTS)
- Gold (HD4ACTY)
- Purple (HD4ACTP)
- Blue (HD4ACTB)
- Black (HD4ACTK)
- Red (HD4ACTR)
- Green (HD4ACTG)



PART# NS-CTB

Clear grease tube

W/ anodized aluminum rings

Available Colors

- Silver (NS-CTS)
- Gold (NS-CTY)
- Purple (NS-CTP)
- Blue (NS-CTB)
- Black (NS-CTK)
- Red (NS-CTR)
- Green (NS-CTG)





Specifications

100-Pc. Grease Fitting Assortment Kit Includes 70 Grease Fittings & 30 Grease Fitting Caps Available in Standard or Metric			
PART # 10066 (Standard)		PART # 10066M (Metric)	
Fitting Size	Quantity	Fitting Size	Quantity
1/4"-28 Straight	15	M6x1 Straight	15
1/4"-28 45°	10	M6x1 90°	10
1/4"-28 90°	10	M8x1 Straight	15
1/8"-27 Short Straight	15	M8x1 90°	5
1/8"-27 Short 45°	10	M10x1 Straight	15
1/8"-27 Short 90°	10	M10x1 90°	10
Grease Caps:		Grease Caps:	
Red (10), Black (10), Yellow (10)		Red (10), Black (10), Yellow (10)	



Specifications

80 piece grease fitting assortment. Plastic refillable box contains 6 most popular fittings in standard and metric sizes.					
PART # 66 (Standard)		PART # 66M (Metric)		PART # 66SS (Stainless)	
Fitting Size	Quantity	Fitting Size	Quantity	Fitting Size	Quantity
1/8" NPT straight	25	M6 x 1 straight	20	1/8" x 27 straight	10
1/8" NPT 45° angle	10	M8 x 1 straight	15	1/8" x 27 45° angle	5
1/8" NPT 90° angle	10	M10 x 1 straight	15	1/8" x 27 90° angle	5
1/4" x 28 straight	15	M6 x 1 90° angle	10	1/4" x 28 straight	10
1/4" x 28 45° angle	10	M8 x 1 90° angle	10	1/4" x 28 45° angle	5
1/4" x 28 90° angle	10	M10 x 1 90° angle	10	1/4" x 28 90° angle	5



PART# 50Y
Yellow Grease Fitting Caps
(50) Yellow caps in bag



PART# 50R
Red Grease Fitting Caps
(50) Red caps in bag

PART# 50SP
Skinpack Grease Fitting Caps
(10) Yellow | (10) Red



PART# 50SP

GREASE FITTINGS

GREASE

Standard, Button Head, Metric Fittings & Tools

All Fittings Are Available In Varied Quantities. See Price Sheet

Standard Fittings

Part #	Description
62	1/4" NPT straight
69	5/16" straight drive type
82SP	3/16" straight drive type
83SP	1/4" straight drive type
70	1/8" NPT straight
71	1/8" NPT 45° angle
72	1/8" NPT 90° angle
73	1/4" x 28 straight
74	1/4" x 28 45° angle
75	1/4" x 28 90° angle
78	1/8" NPT 30° angle
79	1/8" NPT 65° angle



Button Head Fittings

Part #	Description
34	1/8" NPT for 5/8" standard
37	1/4" NPT for 5/8" standard
38	1/4" NPT for 7/8" giant
39	3/8" NPT for 7/8" giant



Metric Fittings

Part #	Description
59	M10x1 straight fitting.
60	M6x1 straight fitting.
61	M8x1 straight fitting.



PART# 77SP

Grease Fitting Assortment In Blister Pack	
Fitting No.	Quantity
70	2
71	1
72	1
73	2
74	1
75	1
78	1
79	1



77SP

GREASE FITTING TOOLS



PART # 49SP

- Taps 1/8" NPT.
- Wrench fits 7/16" and 3/8" hex.
- Easy out for 1/8" NPT



PART # 51SP

- Taps 1/4" 28.
- Wrench fits 5/16" and 3/8" hex.
- Easy out for 1/4" 28.

GREASE FITTING TOOLS



PART # 85SP

- "Drive Fit" grease fitting tool for straight fittings



PART # 87SP

- "Drive Fit" grease fitting tool for angled fittings



Premium quality whip hose for hand operated grease guns. Offers maximum flexibility and long lasting construction.

PART# 12R, 18R & 19R

Features

- Rubber construction - inner tubing is Polyamide with polyurethane sheathing, reinforced diagonally in high tear resistant polyester.
- 1/8" NPT brass fittings



Specifications

Part #	Description	Max PSI
12R	12" x 13/32"	3000 PSI
12R-1	12" x 13/32" In poly bag	3000 PSI
12R-SP	12" x 13/32" Blister packed	3000 PSI
13R	12" x 13/32" 2 Wire braid	5000 PSI
18R	18" x 13/32"	3000 PSI
18R-1	18" x 13/32" In poly bag	3000 PSI
18R-SP	18" x 13/32" Blister packed	3000 PSI
18RR	18" x 13/32" 2 Wire braid	5000 PSI
19R	24" x 13/32"	3000 PSI
19R-SP	24" x 13/32" Skin packed	3000 PSI
36R	36" x 13/32"	3000 PSI
36R-SP	36" x 13/32" Skin packed	3000 PSI

Standard duty thermoplastic constructed whip hose for hand operated grease guns. Offers high efficiency at maximum savings.

PART# 12G, 18G & 19G

Features

- Thermoplastic with polyester braid
- 1/8" NPT steel fittings



Specifications

Part #	Description	Max PSI
12G	12" x 5/16"	3000 PSI
18G	18" x 5/16"	3000 PSI
19G	24" x 5/16"	3000 PSI

NOTE: All hoses (except for 5000 PSI) are for use with HAND OPERATED grease guns only



12R-SP



18R-SP



Flexible Position



Rigid Position



PART# 11SP

Flexible & Rigid Extension Adapter

Features

- Maximum working pressure 5000 PSI
- Allows operator to switch from flexible to rigid extension with one hand.
- Overall length 13"
- 1/8" NPT (M)

HYDRAULIC COUPLERS

Premium Standard & Heavy-duty Couplers

All Hydraulic Couplers Are 1/8" NPT (F)

GREASE

PART# 25

10,000 PSI
Heavy-duty 3-Jaw
hydraulic coupler with
ball check .670" (OD)



PART# 44

15,000 PSI
Heavy-duty 3-Jaw
hydraulic coupler
with ball check for air
operated equipment .662" (OD)



PART# 25SP

Same as Part# 25
(Blister Packaged)



PART# 47SP

(Blister Packaged)
1,000 PSI
Right angle hydraulic
coupler



PART# 27

6,000 PSI
Standard 4-Jaw
hydraulic coupler with
ball check .590" (OD)



PART# 48

360° swivel coupler
assembly



PART# 27SP

Same as Part# 27
(Blister Packaged)



PART# 48SP

Same as Part# 48
(Blister Packaged)



PART# 28

6,000 PSI
Standard 3-Jaw
hydraulic coupler with
ball check .590" (OD)



PART# 52

7,000 PSI
Zinc plated swivel coupler
with ball check Locks at
any 45° position for easy
access to most grease fittings



PART# 28SP

Same as Part# 28
(Blister Packaged)



PART# 52SP

Same as Part# 52
(Blister Packaged)



Couplers & Adapters

Recommended For Use With Manual Grease Equipment

PART# 10

(Available in a skin pack 10SP)
Steel Grease Pipe

Features

- 1/8" NPT (M) both ends.
- Approximately 10" long with 15° bend



PART# 31

(Available in a skin pack 31SP)
Standard Button Head Coupler

Features

- For 5/8" button head fittings
- 1/8" NPT (F) inlet



PART# 22

(Available in a skin pack 22SP)
Needle Point

Features

- 1/8" NPT (F)
- Needle only is 1/8" x 1 1/2" long



PART# 32

(Available in a skin pack 32SP)
Giant Button Head Coupler

Features

- For 7/8" button head fittings
- 1/8" NPT (F) inlet



PART# 23

(Available in a skin pack 23SP)
Seal-Off Adapter

Features

- 1/8" NPT (F)
- Diameter .394"
- Length 1 1/2"



PART# 55

(Available in a skin pack 55SP)
Steel Grease Pipe

Features

- 1/8" NPT (F)
- Approximately 5 1/2" long with 15° bend



PART# 24

Coupler Connector

Features

- 1/8" NPT (M)



PART# 65

(Available in a skin pack 65SP)
Sealed Bearing Lubricator

Features

- Fits grease gun coupler
- Needle only is 1/16" x 1 1/2"



PART# 29

Filler Pump Valve

Features

- 1/4" NPT (F) fits on grease gun filler pumps (P/N 327 or P/N 328)



PART# 80

(Available in a skin pack 80SP)
Loader Nipple

Features

- 1/8" NPT (M) for filling from gun filler pump.
- Fits most grease guns



ELECTRIC FUEL PUMPS

FUEL

12 Volt & 115 Volt Cast Aluminum Fuel Pumps

Recommended For Gasoline, Kerosene & Diesel Fuel, Mineral Spirits Heptane & Stoddard Solvent

PART# 925

12 Volt DC Electric Gear Pump
Flow rate up to **15-GPM**

PART# 930

115 Volt AC Electric Gear Pump
Flow rate up to **15-GPM**

PART# 945

12 Volt DC Electric Gear Pump
Flow rate up to **20-GPM**



Features (All Models)

- Aluminum die cast construction
- UL approved explosion proof motor with sintered powered metal gears
- Fits 15-55-gallon drums
- Positive displacement
- Nozzle holster w/lock
- Duty cycle 30 minutes on, 30 minutes off
- Two piece 34" long Suction tube
- Tank adapter 2" threaded

Specifications

Part #	925	930	945
Motor	12 Volt DC - 1/7-HP	115 Volt AC - 1/8-HP	12 Volt DC - 1/7-HP
Inlet	1" NPT	1" NPT	1" NPT
Outlet	3/4" NPT	3/4" NPT	1" NPT
Hose	3/4" x 12-ft. Anti-static	3/4" x 12-ft. Anti-static	1" x 12-ft. Anti-static
Power Cord	15-ft. (13ga.)	N/A	15-ft. (13ga.)
Draw	12-amp	1.7-amp	15-amp
Nozzle	Manual	Manual	Manual

- All models have a removable wire mesh strainer for easy cleaning without disassembly of the pump.
- Wetted components are aluminium, steel, cast iron, nylon, NBR, zinc, FKM, polypropylene and PVC.

ELECTRIC FUEL PUMPS

12 Volt & 115 Volt Fuel Pumps

For Gasoline, Diesel, Kerosene, Mineral Spirits, Heptane & Stoddard Solvent



PART# 926

12 Volt DC Electric Vane Pump

PART# 927

115 Volt AC Electric Vane Pump

Features (926 & 927)

- Fits 15-55-gallon drums
- Positive displacement
- Manual nozzle holster with lock
- Duty cycle 30 minutes on, 30 minutes off
- Includes two piece PVC suction tube

Specifications

Part #	926	927	942
Motor	12 Volt DC - 1/4-HP	115 Volt AC - 1/4-HP	12 Volt DC - 1/4-HP
Flow Rate	13 GPM	13 GPM	20 GPM
Construction	Cast Iron	Cast Iron	Cast Iron
Inlet	1" NPT	1" NPT	1" NPT
Outlet	3/4" NPT	3/4" NPT	1" NPT
Hose	3/4" x 10-ft. Anti-static	3/4" x 10-ft. Anti-static	1" x 12-ft. Anti-static
Power Cord	15-ft. (12GA.)		18-ft. (12GA.)
Draw	20-amp	2-amp	22-amp



PART# 942

12 Volt High Flow Fuel Transfer Pump
Pumps gasoline or diesel from bulk tanks to cars, trucks or other equipment

Features

- Thermal overload protected / internal bypass valve
- Cast iron rotor / Machined bronze vanes
- Fuel inlet strainer
- Nozzle holster with lock
- Duty cycle 30 minutes on, 30 minutes off
- U.S. & Canadian UL Listed; CE approved motor
- All steel telescoping suction tube



PORTABLE FUEL DISPENSER

PART# 924

For transferring kerosene, diesel fuel, antifreeze & hydraulic fluid

Features

- 12-Volt DC / light-duty / 8 to 10.5 GPM
- Cast iron construction / aluminum nozzle
- 3/4" barbed Inlet / Outlet
- Includes battery cables and clips
- Built in bypass valve and on/off switch
- Self-priming, positive displacement
- 13-ft hose for suction and discharge

Not for Gasoline / Not UL Listed

ELECTRIC FUEL PUMPS

12 Volt & 115 Volt Cast Aluminum Fuel Pumps

Recommended For Gasoline, Kerosene & Diesel Fuel

Convenient spin collar for easy installation on 2" NPT Bung

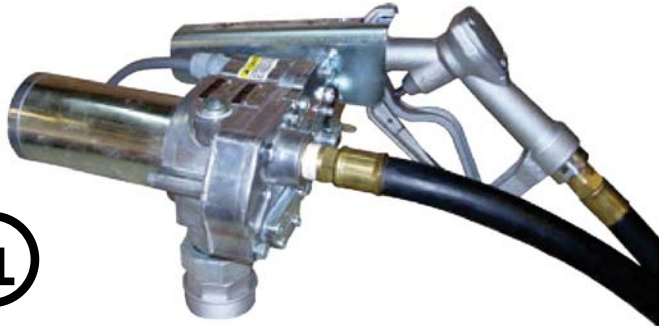

FUEL

PART# 928

Electric Gear Pump W/15-ft.
(4.6m) 12-gauge Cord
12-V fuel pump w/ overload protected motor

PART# 933

Electric Gear Pump
115-V fuel pump w/ overload protected motor

Part #	928	933
Motor	12 Volt DC	115 Volt AC - 1/4-HP
Flow Rate	15 GPM	15 GPM
Construction	Cast Aluminum	Cast Aluminum
Suction Lift	5 1/2-ft.	5 1/2-ft.
Discharge Lift	19 1/2-ft.	19 1/2-ft.
Operating Temperature	-20° to +125° F	-20° to +125° F
Connection	2" NPT	2" NPT
Inlet	1" NPT	1" NPT
Outlet	3/4" NPT	3/4" NPT
Hose	3/4" x 12-ft. Anti-static	3/4" x 10-ft. Anti-static
Power Cord	15-ft. (12GA.)	
Draw	18-amp	1.5-amp

Features (928 & 933)

Nozzle: Manual shutoff, unleaded spout
Security: Nozzle can be padlocked
Suction Pipe: Plastic, adjustable 22" to 40"

Mechanical & Digital Fuel Meters

PART# 1514 & 1514L

Mechanical Meter with Strainer



1514 & 1514L (Also Available in 1" NPT In/Out 1514-1)	
Units of Measure	
1514	U. S. Gallon
1514L	Liters
Flow Rate	4 to 20 GPM
Accuracy	± 2%
Design Type	Nutating Disc
Housing	Aluminum
Max. Working Pressure	50 PSI
Inlet/Outlet	3/4" or 1" NPT
Maximum Batch Total	999.9
Maximum Cumulative Total	999,999
Dimensions	5.5" X 4.5" X 5.5"

PART# 1512

Electronic Digital Fuel Meter



1512	
Units of Measure (Changeable)	Pints, Quarts, Liters, or Gallons
Flow Rate (Pump or Gravity Feed)	1 to 32 GPM
Accuracy	± 1%
Design Type	Turbine
Housing	Poly
Max. Working Pressure	300 PSI
Working Temperature Range	14°F - 122°F
Inlet/Outlet	1" NPT
Required batteries	2 X AAA
Maximum Batch Total	9999
Maximum Cumulative Total	99999
Dimensions	2.75" X 3" X 2.25"

Display can be changed by rotating the card in its housing thus ensuring great versatility in positioning

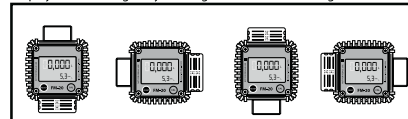

Nozzles & Swivels

Recommended For Gasoline, Diesel Fuel, Kerosene



Manual Nozzles

Automatic Nozzles

**Manual Nozzles
W/Swivel**

Fuel Nozzle Display (10ct.)

1537-10, 1537C-10,
1538-10, 1538C-10,
1539-10, 1539C-10

UL Listed

Part #	Spout	Inlet	Outlet	Automatic Nozzle	Swivel	Locking Trigger
1537	Straight	1"	1"	No	No	Yes
1537-10	Straight	1"	1"	No	No	Yes
1537C	Curved	1"	1"	No	No	Yes
1537C-10	Curved	1"	1"	No	No	Yes
1537WS	Straight	1"	1"	No	Yes	Yes
1538	Straight	3/4"	3/4"	No	No	Yes
1538-10	Straight	3/4"	3/4"	No	No	Yes
1538C	Curved	3/4"	3/4"	No	No	Yes
1538C-10	Curved	3/4"	3/4"	No	No	Yes
1538WS	Straight	3/4"	3/4"	No	Yes	Yes
1539	Straight	1"	3/4"	No	No	Yes
1539-10	Straight	1"	3/4"	No	No	Yes
1539C	Curved	1"	3/4"	No	No	Yes
1539C-10	Curved	1"	3/4"	No	No	Yes
1541	Curved	3/4"	13/16"	Yes (Black)	No	Yes
1542	Curved	3/4"	15/16"	Yes (Black)	No	Yes
1543	Curved	1"	1"	Yes (Green)	No	Yes
15441	Curved	True 1"	True 1"	Yes (Green)	No	Yes



! Warning swivels are not UL listed !

Optional Accessories

- Part# 75000 3/4" NPT Dual Plane Swivel
- Part# 75100 1" NPT Dual Plane Swivel

DEF Nozzles



DEF
Compatible

DEF
Compatible

PART# DEF-15

Plastic Manual Nozzle

- Locking trigger for hands-free operation
- Stainless steel spout
- 3/4" Hose barb
- FKM seals
- 0.75" OD Spout

PART# DEF-906

Stainless steel Automatic Nozzle

- Locking trigger for hands-free operation
- Stainless steel spout
- FKM seals
- 0.75" OD Spout

Optional Accessories (For DEF-906)

PART# DEF-107233

3/4" Hose barb x 3/4" NPT SS Swivel



DEF
Compatible

DIESEL EXHAUST FLUID

FUEL

Electric & Hand Operated Pumps

Recommended For Pumping DEF (Diesel Exhaust Fluid)

PART# 10231TK

DEF 10231 Tote Mounting Kit

Features

- Kit includes a 3 vane rotary Pump (10231)
- Pumps 1 gal per 10 rotations.
- DEF hose (8') to be cut for a pick up tube and the suction hose to the pump.
- Buttress plug (Qty 2) One for the suction tube, and one for the breather.
- Fittings kit (Includes all fittings & clamps to make connection to the tote)
- Mounting bracket with adjustable shelf for a 2.5 gal container. Adjust down for taller containers.
- Mounting bracket is powder coated and clamps to the tote for stable pumping.
- 46" Discharge hose and SS clamp.
- Stays primed with DEF at all times once started.
- Optional drum adapter plate (10231TBC)



PART# 9115

115 Volt AC Diaphragm Pump (12Volt DC Part# 9112)

Features

- 9 -GPM (.45 HP Motor)
- Voltage 115 volts AC/ 3.5 amps
- 3/4 Hose barb inlet/outlet (w 3/4" BSP Threads)
- DEF kits available
- Optional drum adapter plate (10231TBC)

Part# 9115
(Pump Only)



Part#
9115TKSN



Part# 3713
Micro-Matic Valve
Not included w/ 9115TKBS



Part# DEF-504G Meter

Available Kits

Part #	9115TKBS	9115TK	9115TKSN	9115TKSNM
Pump	115-Volt AC (9115)	115-Volt AC (9115)	115-Volt AC (9115)	115-Volt AC (9115)
Inlet Hose	4' (08DEF750)	4' (08DEF750)	4' (08DEF750)	4' (08DEF750)
Outlet Hose	20' (08DEF750)	20' (08DEF750)	20' (08DEF750)	20' (08DEF750)
Suction Hose	5' (08DEF750)	No	No	No
Micro-Matic Connection	No	Yes (3713)	Yes (3713)	Yes (3713)
Meter	No	No	No	Digital (DEF-504G)
Nozzle	Plastic (DEF-15)	Plastic (DEF-15)	Automatic SS (DEF-906)	Automatic SS (DEF-906)

*Kits Also Available With 12-Volt DC Pump

DIESEL EXHAUST FLUID

Hand Operated Pumps

Recommended For Pumping DEF (Diesel Exhaust Fluid)



PART# 369
Polyethylene Construction



PART# 365
Nylon Construction



PART# 375
Polypropylene Construction



PART# 10211
Polypropylene Construction



PART# 387
Stainless Steel Construction



PART# 10193
Stainless Steel Construction



PART# 11219
Stainless Steel Construction



PART# 373
Polypropylene Construction

Part #	Container	Output	Seals
369	15-55 gallon	Siphons 7gal. per min	N/A
365	15-55 gallon	1gal. per 8 lifts	PTFE
373	15-55 gallon	1pint per stroke	Acetal
375	15-55 gallon	1gal. per 10 strokes	FKM
10211	15-55 gallon	1gal. per 16 revolutions	FKM
387	15-55 gallon	1gal. per 8 lifts	PTFE
10193	15-55 gallon	1gal. per 13 strokes	PTFE
11219	15-55 gallon	1gal. per 24 revolutions	PTFE

Attention - Hand equipment includes 2" NPT bung adapter.
DEF plastic drums & totes have 2" buttress threads.



Optional Accessories

PART# 151

Features

- Buttress thread adapter
- Nylon construction
- Converts 2" buttress thread to 2" NPT



PART# 5072

Threaded Micro-Matic™ Coupler (Coupler Only)

Features

- 1" NPT Male Threads
- Available in a Pump Kit 11219MM (Shown Above)

DIESEL EXHAUST FLUID

Air, Electric, Hand Operated Pumps & Meters
Recommended For Pumping DEF (Diesel Exhaust Fluid)

FUEL

PART# DEF-005 PART# DEF-005EC

115-Volt Economy DEF Pump System



DEF Pump Systems

•Sealed solution bung adapter w/buttress thread

Part #	Container	Tube length	Output	Nozzle	Hose
DEF-005	55 gallon	40"	5 GPM	Auto/SS	8-ft
DEF-010	275 gallon	48"	5 GPM	Auto/SS	8-ft
DEF-020	330 gallon	54"	5 GPM	Auto/SS	15-ft
DEF-027	55 gallon	40"	10 GPM	Auto/SS	8-ft
DEF-028	275 gallon	48"	10 GPM	Auto/SS	8-ft
DEF-005EC	55 gallon	40"	5 GPM	Manual/Poly	8-ft
DEF-010EC	275 gallon	48"	5 GPM	Manual/Poly	8-ft
DEF-020EC	330 gallon	54"	5 GPM	Manual/Poly	15-ft
DEF-027EC	55 gallon	40"	10 GPM	Manual/Poly	8-ft
DEF-028EC	275 gallon	48"	10 GPM	Manual/Poly	8-ft

DEF Hose

Part #	Size	Connections / Discharge
08DEF750	3/4" ID Sold by the foot	Open

Warning: All DEF Hose, Pumps and Nozzles should be flushed out with DEF or De-ionized water after assembling. All DEF hose meets ISO 22241 and NFPA 70 Standards

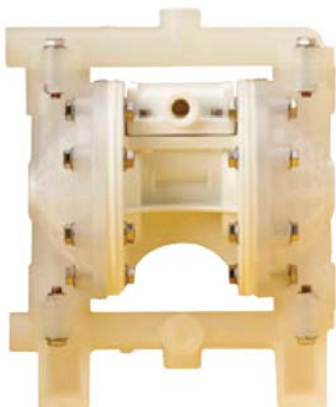

PART# 1035SP

Air Operated
1:1 Double Diaphragm Pump

- Flow rate 14 GPM
- 1/2" NPT inlet/outlet
- Non-stalling

PART# DEF-504G

Nylon Digital Turbine meter

- 1" NPT Inlet/outlet
- Flow rate 1 to 32 GPM
- Powered by 2 AAA Batteries
- 300 PSI



NEW
IMPROVED METER

PART# DEF-15

Plastic Nozzle

- Stainless steel spout
- 3/4" Hose barb
- FKM seals
- Locking trigger
O.D. 3/4"



PART# DEF-906

Stainless Steel Automatic Nozzle

- Locking trigger for hands-free operation
- Stainless steel spout
O.D. 3/4"



Optional Accessories (For DEF-906)

PART# DEF-107233

3/4" Hose barb x 3/4" NPT SS Swivel



DEF HOSE REEL



PART# DEF-7925

Features

- 25' X 3/4" NPT Hose - 250 PSI
- Stainless steel fittings & flow path
- Steel construction
- Weight: 42lbs

PART# 3713



PART# 5702



PART# 5072



PART# 5792

2.5" x 5 Buttress Threads
One opening is slightly angled and one is straight to maximize footprint on cap to connect Fill and Dispense Couplers.



PART# DEF-601



Part #	Description
3713	Stainless Steel Micro-Matic™ Coupler With 3/4" Barbed Outlet
5072	Stainless Steel Threaded Micro-Matic™ Coupler 1" NPT Threads
5702	Composite Micro-Matic™ Coupler With 3/4" Barbed Outlet
5792	6" Composite Two Hole IBC Center Cap (Optimized for Filling and Dispensing)
DEF-601	Polypropylene Cam Lock Coupler With 3/4" Hose Barb and EPDM Seals

HAND FUEL PUMPS

FUEL

Hand Diaphragm Pump & Lever Style Pump

Recommended for Gasoline, Diesel Fuel, Antifreeze & Glycol

Premium Quality Pump

PART# 30A1

Manual Diaphragm Pump

Specifications

Part #	30A1
Dispenses	1-gallon per 8 strokes
Container	15-55 gal. drum
Bung Adapter	2" NPT (L30-79N)
Suction Tube	22" to 39" telescoping (L30-99N)
Hose	8-ft. (L30-95N)
Lockable Handle	Yes
Discharge Nozzle	Yes (L30-90N)

Optional Accessories

- Tank brace (L30-94N)
- Repair kit (L302193)
 - a) One (1) Diaphragm (L30-30N)
 - b) One (1) Seal (L30-35N)
 - c) Two (2) Reed valves (L30-52N)

PART# L30-94N

Tank Brace



PART# 202

Bio-Diesel / E85 Hand Pump

Features

- Rugged steel construction
- Delivers approx. 1-gal. per 9 strokes
- Yellow powder coated finish
- PTFE seals
- FKM O-ring
- Garden hose type threads on spout
- Telescoping suction tube



PART# 103

Hand Operated Transfer Pump

IMPORTANT! NOT Suitable For Water Based Fluids

Features

- Carbon steel construction
- Double check valve
- FKM O-Ring
- 2 pieces (4 ft. each) clear vinyl hose
- 2 1/4" x 11" barrel size
- Dispenses 14 oz. per stroke



For Removing Microscopic Particles From Fuels

Recommended For Regular Grades Of Gasoline, Diesel Fuel & 10% Ethanol

Fuel filters for removing microscopic particles (up to 10 microns) of dirt, rust, sand and scale from gravity feed tanks, hand pumps and electric fuel pumps



PART# NS-10

Fuel Filter

CAUTION! This unit should not be used unattended for safety reasons

Features

- Element has 366 square inches of filter surface for efficient filtration and optimum life
- Translucent bowl to monitor fuel flow
- 5 GPM gravity flow with 24" head

PART# 20

Replacement Element

(Part # 20 comes with both replacement gaskets)



Attractive 6 pack display box
Retail display box included in all case quantities

PART# 175

Filter Wrench for the NS-10 Filter



Specifications

Part #	Description	Thread
NS-10	Fuel Filter	1" NPT
NS-10-BSP	Fuel Filter with BPT threads	1" BPT
NS-10W	Water Block Fuel Filter	1" NPT
20	Replacement Element	
20WB	Water Block Element	
BOWL	Replacement Bowl for fuel filters	



PART# NS-30

Fuel Filter

Features

- 10 Micron filter assembly with aluminum head
- 20 GPM Max flow rate
- Max working pressure 50 PSI
- Cartridge uses a 1.5-16 UNF thread
- Has three 5/16-18 BSW threads in the top of head for mounting

Specifications

Part#	Description	Thread
NS-30	Fuel Filter Assembly	1" NPT
NS-30AR	Filter Head Only	1" NPT
NS-40	Filter Element	
NS-40WB	Water Block Element	

PART# NS-30AR



PART# NS-40



IMPORTANT! Not recommended for water based products, aviation fuels, race fuels or gasoline containing more than 10% ethanol

ROTARY PUMPS

Cast Iron Rotary Pumps

Recommended For Gasoline, Diesel Fuel & Light Oil

FUEL

PART# 960



PART# 961



PART# 962



PART# 963



Retail packaging for all 4 models

Specifications

Part #	960	961	962	963
Dispenses	1-gal. per 13 revolutions	1-gal. per 13 revolutions	1-gal. per 13 revolutions	1-gal. per 13 revolutions
Container	15-55 gal. drum	15-55 gal. drum	15-55 gal. drum	15-55 gal. drum
Construction	Cast iron	Cast iron	Cast iron	Cast iron
Vanes & Seals	Cast iron / NBR	Cast iron / NBR	Cast iron / NBR	Cast iron / NBR
Bung Adapter	2" NPT	2" NPT	2" NPT	2" NPT
Suction Tube	3 pc. Rigid	3 pc. Rigid	Telescoping Suction Tube	Telescoping Suction Tube
Bi-directional	Yes	Yes	Yes	Yes
Hose	No	8-ft. (L30-95N)	No	8-ft. (L30-95N)
Water Deflector	WD950	WD950	WD950	WD950
Spout*	3/4" NPT (M)	3/4" NPT (M)	3/4" NPT (M)	3/4" NPT (M)
Discharge Nozzle	No	Manual (L30-90N)	No	Manual (L30-90N)
Nozzle Holster	No	Holster (53)	No	Holster (53)

* 1" BSPT on pump inlet.

Cast Iron Rotary Pumps

Recommended For Gasoline, Diesel Fuel & Light Oil



PART# 1002

Pickup Tube Screen



PART# 1003

Unassembled

Specifications

Part #	1002	1003
Dispenses	1-gal. per 13 revolutions	1-gal. per 13 revolutions
Container	15-55 gal. drum	15-55 gal. drum
Construction	Cast iron	Cast iron
Vanes & Seals	Cast iron / NBR	Cast iron / NBR
Bung Adapter	2" NPT (96023)	2" NPT (96023)
Suction Tube	3 pc. Steel w/screen	3 pc. Steel w/screen
Bi-directional	Yes	Yes
Hose	No	8-ft. (L30-95N)
Water Deflector	WD950	WD950
Spout	3/4" NPT (M)	3/4" NPT (M)
Discharge Nozzle	No	Manual (L30-90N) Holster (53)



(Optional accessory)

PART# 169

Non-sparking drum wrench

ROTARY PUMPS

3-Vane Cast Iron Rotary Pumps
Recommended For Gasoline & Diesel Fuel

FUEL

Heavy Duty Bi-Directional Rotary Vane Hand Pumps

PART# 1007

PART# 1007H

Includes 8-ft section of vinyl hose (2158)



PART# 1006

PART# 1006H

Includes 8-ft section of fuel resistant hose (L30-95N)



PART# 1006HFM

FM Approved Rotary Pump



Features













- Cast iron construction
- For 15-55-gallon drums
- Telescoping suction tube
 - minimum length 20"
 - maximum length 40"
- Bi-directional
- 3 self adjusting vanes
- Dispenses 1-gallon per 10 revolutions
- Smooth operation
- 2" NPT Bung adapter
- 3/4" NPT discharge spout (M)

Specifications

Part #	1006	1006H & 1006HFM
Dispenses	1-gal. per 13 revolutions	1-gal. per 13 revolutions
Container	15-55 gal. drum	15-55 gal. drum
Construction	Cast iron	Cast iron
Vanes & Seals	Cast iron / Graphite	Cast iron / Graphite
Bung Adapter	2" NPT	2" NPT
Suction Tube	Telescoping	Telescoping
Bi-directional	Yes	Yes
Hose	No	8-ft. (L30-95N)
Spout	3/4" NPT (M)	3/4" NPT (M)
Discharge Nozzle	No	Non-sparking with Holder

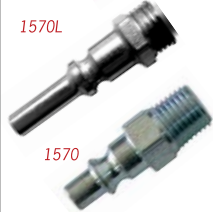

Hose Included with Part# 1007H (2158)

Part#	Description		Part#	Description	
1559A-ASSY	Air line filter with nighttime drain, regulator, gauge, ball valve and quick disconnects 40 micron filter 1/4" NPT Inlet/Outlet		1554	Mini air regulator with 4 ports (2) 1/4" NPT and (2) 1/8" NPT (with 1 plug). For air pressure ranging from 0 to 200 PSI	
1559A2-ASSY	1559A-ASSY with 12" hose (2001) Mounting bracket (BRKT-1578) 3/8" X 1/4" Bushing (1167) 1" x 1/4" Hex Nipple (1183) 1/4" NPT Inlet/Outlet		1556BV	Brass ball valve 1/4" NPT (M) x 1/4" NPT (F)	
1573A	Heavy-duty air treatment unit provides moisture-free air with a touch of oil for lubrication. Handles 18 CFM with 100 PSI inlet pressure. Includes filter, gauge, regulator, and oiler. 1/4" NPT (F) 40 micron filter		1560	Air gauge with 2" dial face. 1/4" NPT bottom connection for 0 to 200 PSI.	
1558A	High-flow 1/4" NPT inlet air line filter with a nighttime drain. Flow rate = 60 CFM with 90 -120 PSI inlet pressure. Maximum pressure 150 PSI. 1/4" NPT (F) 40 micron filter		1561	Air gauge with 2" dial face. 1/8" NPT center back connection for 0 to 200 PSI	
1559A	Mini air line filter with automatic drain. Die cast body with 2 ports. Maximum air pressure 150 PSI (10 bar) 40 micron filter 1/4" NPT (F)		1565L	Zinc plated quick connect air coupler 1/4" NPT (Current Style) For equipment prior to 2014 please order Part# 1565	
1578	Mini air line filter with nighttime drain. Die cast body with 2 ports. Includes filter, gauge, and regulator. Maximum air pressure 150 PSI (10 bar) 1/4" NPT (F) 40 micron filter		1570L	Air Nipple. 1/4" NPT thread (Current Style) For equipment prior to 2014 please order Part# 1570	
1574	Combo unit for high air flow. Includes 3/8" NPT inlet and outlet, regulator, gauge, oiler and filter. Protective metal covering for all bowls. Manual water drain		1183	Air Nipple. 1/4" NPT thread	

HOSE ASSEMBLIES

For Grease, Oil, Air & Water
Hoses Available In Vinyl, Rubber & Nitrite/PVC Blend

ACCESSORIES



Part #	Material Type	Size	Compatible With	Connections / Discharge
36	Clear vinyl	1/2" x 5-ft.	D-S, 338, 366, 381	Garden hose / open
88	Clear vinyl	1/2" x 8-ft.	D-S, 338, 366, 381	Garden hose / curved nozzle
2154	Clear vinyl	3/4" x 4-ft.	960, 1002	3/4" NPT (F) / open
2156	Clear vinyl	3/4" x 6-ft.	960, 1002	3/4" NPT (F) / open
2158	Clear vinyl	3/4" x 8-ft.	960, 1002	3/4" NPT (F) / open
2134	Clear vinyl	3/4" x 4-ft.	360, 363, 365	Coupling nut / plastic nozzle
2136	Clear vinyl	3/4" x 6-ft.	360, 363, 365	Coupling nut / plastic nozzle
L30-95N	Black rubber	3/4" x 8-ft.	30A1	3/4" NPT (M) / 3/4" NPT (M)
2178	Black rubber	3/4" x 8-ft.	960, 962, 1007	3/4" NPT (F) / aluminum nozzle
10039-1P	Nitrite/PVC blend	3/4" x 12-ft.	926, 927, 928, 933	3/4" NPT (M) / 3/4" NPT (M)

DEF Hose

Part #	Size	Connections / Discharge
08DEF750	3/4" ID Sold by the foot	Open

Warning: All DEF Hose, Pumps and Nozzles should be flushed out with DEF or De-ionized water after assembling. All DEF hose meets ISO 22241 and NFPA 70 Standards

High Pressure Hose Assemblies

Ideal for air operated grease pumps and hose reels

1/4" I.D. wire braid
Maximum working pressure 5,000-lbs.
Minimum burst pressure 20,000-lbs.
Fittings 1/4" NPT (M) both ends

Medium Pressure Hose Assemblies

Ideal for air operated oil pumps and hose reels

1/2" I.D. fiber braid
Maximum working pressure 1,125-lbs.
Minimum burst pressure 4,500-lbs.
Pressure fittings 1/2" NPT (M) both ends

Low Pressure Hose Assemblies

Ideal for air and water hose reels

1/2" I.D.
Maximum working pressure 250-lbs.
Minimum burst pressure 1,000-lbs.
Fittings 1/2" NPT (M) both ends

High Pressure

Part #	Length
1802	2-ft.
1804	4-ft.
1806	6-ft.
1810	10-ft.
1812	12-ft.
1816	16-ft.
1820	20-ft.
1825	25-ft.
1850	50-ft.

Medium Pressure

Part #	Length
2205	5-ft.
2210	10-ft.
2215	15-ft.
2220	20-ft.
2225	25-ft.
2250	50-ft.

Low Pressure

Part #	Length
2300	1-ft.
2320	20-ft.
2325	25-ft.
2330	30-ft.
2340	40-ft.
2350	50-ft.

Conventional Reels

Recommended For Oil, Grease, Air, Water & Fuel

Heavy-duty For Stationary And Mobile Truck Mounting

PART# 1440R



PART# 1481NS



Conventional Reels

Features

- Steel construction with heavy-duty base
- Dual arm support
- 3-position guide for ceiling, wall or bench mounting
- Adjustable hose stop
- Drum support bushing with self-lubricating material
- Easy and safe replacement of spring can
- Durable powder-coated finish

Specifications

Part #	Product	Hose Length	Max. Pressure	Inlet Thread	Outlet Connection	Dimensions
1440R	Grease	1/4" x 52-ft.	5000 PSI	1/4" F NPT	1/4" M NPT	A
1474R	Grease	1/4" x 39-ft.	5000 PSI	1/4" F NPT	1/4" M NPT	A
1444R	Oil, ATF, Gear Lube	1/2" x 49-ft.	2500 PSI	1/2" F NPT	1/2" M NPT	B
1475R	Oil, ATF, Gear Lube	1/2" x 32-ft.	2500 PSI	1/2" F NPT	1/2" M NPT	A
1448R	Air, Water	1/2" x 49-ft.	300 PSI	1/2" F NPT	1/2" M NPT	B
1456R	Air, Water	3/8" x 39-ft.	300 PSI	3/8" F NPT	3/8" M NPT	A
1458R	Air, Water	3/8" x 59-ft.	300 PSI	3/8" F NPT	3/8" M NPT	A
1481NS	Gasoline, Diesel	3/4" x 50-ft.	50 PSI	3/4" F NPT	3/4" M NPT	C
1482NS	Gasoline, Diesel	1" x 50-ft.	50 PSI	1" F NPT	1" M NPT	D

Dimensions

A Bolt Pattern: 5.500" X 7.700", Overall Height 16.100", Overall Width 7.300"

B Bolt Pattern: 5.500" X 7.700", Overall Height 18.100", Overall Width 7.300"

C Bolt Pattern: 6.000" X 10.000", Overall Height 25.375", Overall Width 10.125"

D Bolt Pattern: 7.875" X 10.500", Overall Height 25.375", Overall Width 15.250"

Low Pressure Air / Water Hose Reel

Features

- Heavy gauge steel stampings with reinforced ribs increase strength.
- The industrial-grade drive spring is protected from the environment.
- Stainless steel torsion spring is used on the latch to insure maximum life.
- Steel components are individually powder coated and teamed with composite materials, which virtually eliminates corrosion.
- Versatile mounting - The guide arm can be adjusted to seven convenient locations.
- Composite spool and steel components make the reel strong yet lighter.

Specifications

Part #	Product	Hose Length	Max. Pressure	Inlet Thread	Outlet Connection	Dimensions
1496NS	Air, Water	1/4" x 25-ft.	300 PSI	3/8" F NPT	1/4" M NPT	A
1497NS	Air, Water	3/8" x 25-ft.	300 PSI	3/8" F NPT	1/4" M NPT	A
1458NS	Air, Water	3/8" x 50-ft.	300 PSI	1/2" F NPT	1/4" M NPT	B



Dimensions

A Bolt Pattern: 2.250" X 6.000", Overall Height 17.875", Overall Width 5.750"

B Bolt Pattern: 2.250" X 6.000", Overall Height 17.875", Overall Width 6.250"

DEF HOSE REEL

PART# DEF-7925

Features

- 25' X 3/4" NPT Hose - 250 PSI
- Stainless steel fittings & flow path
- Steel construction
- Weight: 42lbs

Bolt Pattern: 7.8125" X 3.875"

Note: Other Sizes available upon request



Closed Reels & Static Reels

Closed Reels For Air & Water / Static Reels For Grounding



Overall dimensions

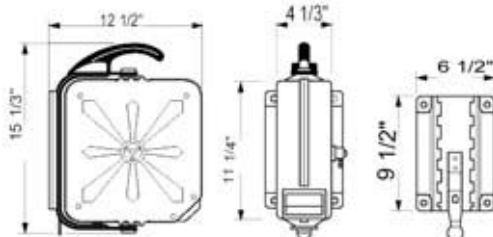

Wall-mounted

PART# 1459

Portable Closed Reel For Air Or Water

Can be moved from mounted location without tools

Features

- 5/16" x 33-ft. service hose with stop
- 1/4" NPT outlet swivel
- Bayonet coupling bracket for easy mounting
- Maximum pressure 150 PSI
- Reel swivels for convenience
- Can be locked with bolt or lock for security
- Includes wall bracket (89001)

Part# 1472NS



Static Reels

Recommended For: Grounding Of Electrically Operated Components

Specifications

Part# 1470NS	Part# 1472NS
100-ft. Cable	50-ft. Cable (Enclosed)

Part# 1470NS



Features

- 50 amp grounding clamp
- 3/32" diameter vinyl coated galvanized steel cable
- Retracting static grounding cable
- Heavy-duty construction
- 1" solid steel center shaft
- Multi-position arm guide (except 1472NS)
- Adjustable cable stop
- Spring rewind with latching device

Light & Electrical Cord Reels

For Ease & Convenience In Managing Work Place Lighting & Electrical

PART# 1476NS

Heavy Duty Power Cord Reel

Features

- Powder coated steel construction
- Wall, ceiling or bench mount
- 45-ft. cord length - 12/3 gauge
- Rating 15A 125V
- U.L. Listed



PART# 1477NS

Heavy Duty Light Cord Reel

Features

- Powder coated steel construction
- Wall, ceiling or bench mount
- 50-ft. cord length - 16/3 gauge
- Rating 10A 125V
- U.L. Listed



Dimensions For Both

Bolt Pattern: 2.500" X 8.000", Overall Height 13.250", Overall Width 9.375"



PART# 913

Features

- Standard cord reel
- 20-ft. cord length
- SVT type
- 18/3 gauge
- Rating 7A 125V
- U.L. Listed
- Maximum 75 watt bulb (not included)

PART# 916

Features

- Fluorescent light cord reel
- 40-ft. cord SJT type
- Efficient 15 watt bulb
- 18/2 90 gauge
- Rating 7A 125V
- U.L. Listed

PART# 918

Features

- Standard cord reel
- 50-ft. cord length
- SVT type
- 18/2 gauge
- Rating 7A 125V
- U.L. Listed
- Maximum 75 watt bulb (not included)



PART# PW005

Features

- 4-gallon capacity
- Solvent capacity 3-gallons
- Steel cover with fusible link
- Steel flexible spigot
- Re-circulates 22-gallons per hour
- Size 17" x 13 1/4" x 9"



PART# PW020

Features

- 20-gallon capacity
- Solvent capacity 12-gallons
- Self latching fire cover with fusible link
- Chrome steel flexible spigot
- Built in drain
- Re-circulates 50-gallons per hour
- Size 31 7/8" x 20 7/8" x 35 3/8"

OILY WASTE CANS



PART# 306

6-gallon Capacity

PART# 310

10-gallon Capacity

Features

- Foot operated cover
- Automatically closes when not in use
- Holds soiled rags and solvent cloths
- FM and UL listed
- Red powder coat finish

PART# 514

Plastic Coated Industrial Gloves

- Heavy-duty abrasion & chemical resistant for handling oil, acids, caustic materials, & many solvents



For Various Size Containers & Openings

PART# 167

Universal Spoke Drum Wrench

Features

- Rugged, all-steel construction
- Powder coated to protect against rust
- 4 different ends
- Can open 3/4" to 2" openings
- Convenient 12" x 12" x 1/2" size



Part# 167

Opens Most drums with ease

PART# 169

Aluminum Drum Wrench

Features

- Non Sparking
- Opens 3/4" slotted bung
- Opens 2" cross bar bung



Part# 169



Part# 10265

PART# 10265

Bronze-Alloy Drum Wrench

Features

- Non Sparking
- Offset handle



Part# 10266



Part# 10267

PART# 10266

Bronze-Alloy Drum Wrench

Features

- Non Sparking
- Built-in 1 1/4" faucet wrench

PART# 10267

Iron-Alloy Universal Drum Wrench

Features

- Fits all drum plugs and bung nuts
- Will not bend or chip under normal use
- Angled handle



Part# 830



Part# 151

PART# 830

Features

- Brass horizontal drum vent
- Threaded 2" NPT

PART# 151

Features

- Buttnut thread adapter
- Nylon construction
- Converts 2" buttnut thread to 2" NPT

For Various Size Containers
Dollies, Trolleys & Carts For Drums



Part# 145

PART# 145

Hand Truck for 100-120 pound drums.

Features

- Specially designed with clamping feature to securely hold drum up to 450 lbs.
- 5" solid rubber wheels.
- 6" X 14" toe plate. 40" high by 17 1/2" wide.



Part# 147

PART# 147

Adjustable trolley for carrying 16-gallon or 120-lb. drums
For creating a portable grease or oil dispensing system

Features

- Drum top hook
- Hose hook
- Meter hook
- Self lubricating plastic and rubber wheels



Drum, meter and pump not included



Part# 148

PART# 148

4 wheel trolley for carrying 16-gallon to 55-gallon drums with a hose reel tray

Features

- Ideal for creating a portable dispensing system with a pump, hose reel, and oil control handle or meter.
- Size of tray: 25 5/8" X 24 5/8"



Drum, meter, reel and pump not included

NEW
IMPROVED DESIGN



Part# 150

PART# 150

3 wheel drum cart for 55gal or 400lb drums

Features

- Easy loading for better mobility of large drums

DRUM HANDLING EQUIPMENT

ACCESSORIES

Drum Dollies & Cradles

For 5 To 55 Gallon Drums

PART# 105



PART# 120



PART# 130-S



PART# 138-S



PART# 140-S



PART# 140-SOR



Specifications

Part #	Container Size	Casters	Diameter Min/Max	Maximum Load
105	5 to 6 1/2-gallon	Phenolic	10" / 11 5/8"	200-lbs.
105-S	5 to 6 1/2-gallon	Steel	10" / 11 5/8"	200-lbs.
120	15 to 16-gallon	Phenolic	13 1/2" / 14 1/4"	200-lbs.
120-S	15 to 16-gallon	Steel	13 1/2" / 14 1/4"	200-lbs.
130-S	30-gallon	Steel	18"	300-lbs.
138-S	55-gallon	Phenolic	23"	450-lbs.
140-S	55-gallon	Steel	23"	450-lbs.
140-SOR	55-gallon	Steel	23"	450-lbs.



PART# 135

Drum Cradle with axle and wheels

PART# 137

Drum Cradle without axle and wheels

PART# 135WC

Drum Cradle with axle and wheels

Specifications

Part #	135	135WC	137
Tips & Rotates	Yes	Yes	Yes
Stores	55 gal. drum	55 gal. drum	55 gal. drum
Self Storing Lever Bar	Yes	Yes	Yes
Capacity	600-lb.	600-lb.	600-lb.
Axel & Wheels	Yes	Yes	No
Casters	No	Yes	No

DRUM ACCESSORIES

Gate Valves, Barrel Faucets & Accessories

For 3/4", 1", & 2" Drum Openings

Part# 57



Part# 63



Part# 64



Part# 67



Empties 55-gallon in 3 min.

Part# 68



Part# 81



Part# 89



Specifications

Part #	Fits	Construction	Manual / Automatic	Lockable
57	1" NPT	Cast Iron	Manual	No
63	3/4" NPT	Cast Iron	Manual	No
64	2" NPT	Cast Iron	Manual	No
67	2" NPT	Polyethylene	Manual	No
68	3/4" NPT	Polyethylene	Manual	Yes
81	3/4" NPT	Die-cast Metal	Automatic (Self Closing)	Yes
89	2" NPT	Aluminum	Automatic (Self Closing)	No

NEW

PART# 5003

Sealed Vent Cap With Cast Iron Base
Stops Fuel Evaporation



Cap opens at 2.5 PSI
Vent opens at 1.5 oz.

Part# 5002 (Cap Only)



Cast Iron Base



PART# 5001

Features

- Vented fill cap
- Lockable
- Threaded 2" NPT



PART# 782



PART# 784



NEW

PART# 784L



PART# 782

2 Drum Spill Containment Pallet

PART# 784

4 Drum Spill Containment Pallet

Note: Ships freight only, 67lb. shipping weight.

PART# 784L

In-Line 4 Drum Spill Containment Pallet

Note: Ships freight only, pallet is poly bagged, 64lb. shipping weight.

Specifications *Note: Other sizes available upon request*

Part #	782	784	784L
Drum Size	2 Drum	4 Drum	4 Drum
Spill Capacity	30 gallons	66 gallons	60.5 gallons
Dimensions	26.25"W x 51.5"L x 6.5"H	51.5"W x 51.5"L x 8"H	30.25"W x 106"L x 6.75"H
Load Capacity	5,000 lb	8,000 lb	8,000 lb

PART# 783

Low Profile Drum Ramp

DIMENSIONS: 45.5" x 32" x 8"

LOAD CAPACITY: 1,500 lbs.



Part# 43



Part# 45

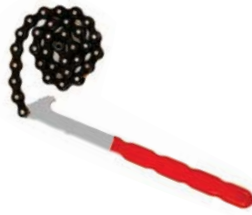

PART# 43

Filter Wrench

For removing standard 3 1/2" to 3 5/8" spin-on filters. 1 1/4" wide plated band and 7" vinyl grip

PART# 45

Chain Type Filter Wrench

For removing spin-on filters up to 4 1/2" in diameter.

Part# 1562



Part# 1563



PART# 1562

Safety Blow Gun

Chrome plated, heavy duty and lightweight. Maximum pressure 30 PSI. Threaded 1/4" NPT (F)

PART# 1563

Air Chuck 1/4" NPT (F)

Part# 1564



Part# 1567



PART# 1564

Engine Clean Gun

For use with solvents or detergents. Blasts off dirt and grime by siphoning solvent and mixing with high air pressure

PART# 1567

Tire Inflating Chuck

Gauge and 12" hose included. Gauge reads from 10-120 lb.

Part# 1588



PART# 1588

1/4" Water Bib

Easily fill radiators

FUNNELS AND DRAIN PANS

ACCESSORIES

Galvanized & Plastic
All Funnels Include A Screen

Part# 86



Part# 701



Part# 703



Part# 705



Part# 707



Part #	Capacity	Spout	Screen	Outlet	Dimensions
86	1-quart	14" Flexible	50 Mesh Brass	7/16" I.D.	6" Diameter
701	1-quart	Straight	Yes	1/2" I.D.	6 1/4" Diameter x 8" Deep
703	8-quart	6" Straight, Lock-on	Yes	1" I.D.	9 1/2" Diameter x 6" Deep
705	6-quart	Straight, Offset	50 Mesh Brass	1" I.D.	10" Diameter
707	9-quart	Straight	Yes	1" I.D.	12" Diameter x 12" Deep

Part# 721

PART# 721

3 1/2-gallon galvanized utility drain pan
15 1/2" diameter x 3 1/2" deep



NEW

PART# 765

Plastic drain pan and parts cleaner
13" diameter x 4" deep

Part# 765



Part# 766



PART# 766

4.5-gallon plastic drain pan w/spout & cap
22.91" x 18.58" x 6.14" deep

PART# 785

Drip Pan

- Fits any 2" NPT Opening
- Strains & returns overflow back to the drum
- Fits pumps with 2" NPT bung

Part# 785



Part# 699J



Part# 769



PART# 699J

Universal Replacement Funnel

- Fits portable oil drains
- Polyethylene construction
- Fits 1 1/2" to 1 7/8" I.D. tube
- Fits the following drains: 309, 316, 318

Part# 776



Part# 778



PART# 769

Deep 3-quart Polyethylene Drum Funnel.

Threaded for 2" openings.
Black only

PART# 776

Extension to Part # 699J

- Allows for larger funnel
- 24" x 24"

Part# 772



Part# 774



PART# 778

Transmission Funnel

- Fits atop Part # 699J
- Increases catch area
- 24" x 37"

Part# 798



PART# 772

55-gallon Drum Funnel

that permits drainage into drum. Ideal for oil cans and drain pans. Durable polyethylene will not rust.

PART# 774

Cover for Part # 772

PART# 798

Threaded Drum Funnel

- 4qt capacity
- Fits 2" openings
- Hinged cover
- Heavy-duty

Part# 799



PART# 799

E-Z Smart Funnel

- 2 Gallon capacity
- Funnel design protects against over filling the drum

PART# 759

Funnel with Screen

- Heavy-duty polyethylene
- 8" diameter
- 7" long x 1/2" flexible spout
- Anti-splash rim w/lid
- 1.75qt capacity
- 1" O.D. outlet

Part# 759



Part# 761



PART# 761

Funnel with Screen

- Heavy-duty polyethylene
- 9" diameter
- 9" long x 7/8" flexible spout
- Anti-splash rim w/lid
- 3qt capacity
- 1" O.D. outlet

Part# 764



PART# 764

Funnel with Screen

- Heavy-duty polyethylene
- 10" x 7" at top
- 1 1/8" O.D. outlet

Part# 770



Part# 775



PART# 770

Deluxe Plastic Funnel

- 11" flexible outlet
- Wide neck for rapid filling
- Handy in hard to reach areas
- 0.625" O.D. outlet

PART# 775

King Size Plastic Funnel

- 4 1/2" diameter
- 17" long x 5/8" outlet
- One piece construction
- 0.625" O.D. outlet

Part# 790



Part# 791



PART# 790, 791

Disposable Paper Funnels

- 32oz Part# 790
- 8.5oz Part# 791
- Sold in packs of 36

Flow Control Measures

Features

- 12" flexible metal spout
- 1/2" diameter outlet
- Black enamel finish
- Non-splash rim
- One-hand operated flow control valve

Specifications

Part No.	Capacity
743	4-Quarts
745	5-Quarts
748	8-Quarts



PART# 93, 94, 95, 97

Pistol Action Oiler

Features

- 6" rigid steel spout and 6" flexible spout
- Deep-drawn seamless body.
- Attractive red painted finish.

Specifications

Part #	Container Size	6" Rigid Steel Spout	6" Flexible Spout
93	6oz	YES	YES
94	1 Pint	YES	YES
95	10 oz	YES	YES
97	1 Quart	YES	YES



NEW



PART# 1000R

Powder Coated Steel Sprayer

Features

- 32oz. Capacity
- Metal Construction
- Brass Nozzle
- Great for bulk application of cleaners, degreasers, penetrating oils, solvents and lubricants

PART# 731 & 732

Features

- 731 4 Liter / 4-quarts
- 732 8 Liter / 8-quarts
- Marked in liters & quarts
- Includes leak proof thread on lid
- Includes outlet cap cover



PART# 737

Battery Filler

- Heavy-duty polyethylene
- Automatic Shutoff
- Non-drip tip
- Safe to use with battery acid
- 1.8qt capacity (2 Liters)



Plastic measures with Flexible spouts

Features

- Marked in quarts & liters
- Flexible spout
- Includes leak proof thread-on lid
- Includes thread-on outlet cap (SPOUT/CAP)
- Polyethylene spout and caps
- HDPE container



Specifications

Part #	Capacity	Lid	Spout
751	1-quart	752G	SPOUT/751/753
753	2-quarts	754G	SPOUT/751/753
755	3-quarts	754G	SPOUT/751/753
757	5-quarts	758G	SPOUT/757
760	6-quarts	758G	SPOUT/757

Disposable Cleaning Towels & Cleaners
Make Clean Up Simple With These Products

Dyna-wipes Dual Sided Disposable Cleaning Towels 9" X 12"



Use For

- Hands
- Tools & equipment
- Stainless steel
- Vinyl
- Leather
- Tennis shoes

Removes

- Coffee stains
- Carpet spots
- Gasket cement
- Plumbers cement
- Permanent marker
- Crayon marks
- Tar & asphalt
- Scuff marks
- Pipe cement
- Labels & Residue
- Urethane sealants
- Paints & varnishes

Specifications

Part#	# of Towels	Textured	Used For
796	80	Yes	Cleaning
796-120	120	No	Cleaning
796-25	30	No	Cleaning
796-25P	30	No	Removes Paint

High Concentrate Cleaners



Features

- Biodegradeable
- Non-Toxic
- Mix With Water 60 to 1

Specifications

Part #	Size	Per Case
796-PMQ	QT.	12
796-PMG	GAL	4

Graffiti Remover



Features

- Clings to a vertical surface
- Removes:
 - Graffiti
 - Paint
 - Adhesive

Specifications

Part #	Size	Per Case
794	1QT. Spray	12
794-G	GAL	4
794-5G	5 GAL	1
794-55G	55 GAL	1

Air Sentry Contamination Control Breathers

The Solution For Fluid Contamination Problems

Unit Selection Guide

Disposable Breathers

Part #	Height	Diameter	Thread
D-100	3 1/2"	5"	
D-101	5"	5"	
D-102	8"	5"	
D-108	10"	5"	2" NPT
D-109	14"	6"	3" NPT
S-154	5"	5"	1" NPT

Disposable Mini Breathers

Part #	Height	Diameter
Z-131	1 3/4"	2"
Z-132	3"	2"
Z-133	1 3/4"	3 1/4"
Z-134	3"	3 1/4"

Adapters

Part #	Description	
A-101	Flange adapter	
A-102	Threaded adapter	1" MNPT
A-103	Threaded adapter	3/4" MNPT
A-104	Bayonet adapter	



Adapter Selection Guide

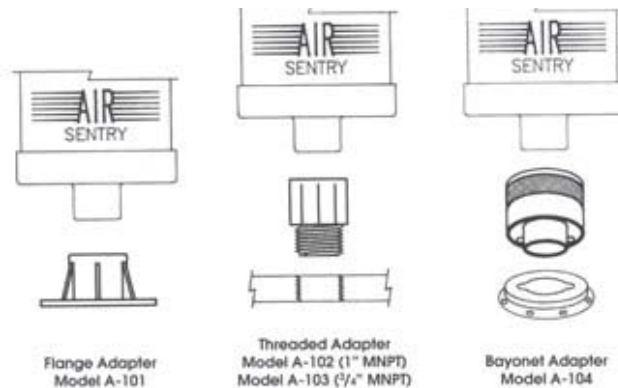

Features

- Blocks corrosive water vapor
- Filters damaging particulate
- Reduces other contaminants
- Protects expensive equipment
- Disposable. Replace when desiccant changes color from gold to green

Air Sentry® Breathers are a unique, patented air filter and vapor removal system. They replace the standard breather or vent cap on virtually all types of industrial equipment, storage tanks, and transformers. They prevent destructive contaminants from entering fluid reservoirs and tanks as air is breathed in and out due to thermal expansion or fluid level changes. Fluid contamination is one of the primary causes of component wear and lubricant failure in industrial equipment.

Models are available to meet the requirements of most industrial applications. Ask your local distributor for technical/sales brochures for any of the products described below:



D-SERIES BREATHERS: The five models in this group satisfy most applications involving hydraulic reservoirs, lubrication and fuel storage tanks, transformers, pumps and gearboxes. Models D-100, D-101 and D-102 are rated for airflow of 35 cfm (260 g.p.m. of fluid level change). They are connected to the tank or reservoir using any of several available adapters. Model D-108 is rated for airflow of 100 cfm (750 g.p.m.) and is connected to the tank by a 2" male pipe thread. Model D-109 is rated for 250 cfm (1875 g.p.m.) and is connected to the tank by a 3" male pipe thread.

Z-SERIES BREATHERS: There are four models of these "Mini Breathers". They are designed for applications where space is limited. They are often used for gearboxes and small reservoirs. The airflow rating of these models is 10 cfm (75 g.p.m.). The connection on all of these units is a 1/2" female thread which mates with several available fittings.



Hand Pumps For 15 - 55 Gallon Drums

Recommended for Light Oil (Max 40 wt.), ATF, Hydraulic Fluid, Kerosene & Diesel Fuel

NEW**PART# 10210****PART# 10191****PART# 10190****PART# 10130****PART# 10080****PART# 10120****PART# 10210**

An economical cast iron pump with steel internals for use with kerosene, diesel fuel, low viscosity oil, etc. (Not for use with water). Comes with 3 piece suction tube and strainer.

- Dispenses approx. 1 gal. per 13 revolutions
- For 15, 30 & 55 gallon containers.
- weight: approx. 12 Lb.

PART# 10130

A fast-flow zinc-plated pump for soaps, waxes and other noncorrosives. Removable spout threaded for 3/4 " garden hose fitting.

- Dispenses approx. 1 gal. per 8 lifts
- For 15 to 55 gallon containers
- Weight: approx. 5 Lb.

PART# 10080

An economical zinc-plated steel pump with polyethylene internal parts for mild soaps, waxes, thinners, etc.

- Dispenses approx. 1 gal. per 16 lifts
- For 15 to 55 gallon containers
- Weight: approx. 3 Lb.

PART# 10191

A Chrome-plated pump for non-waterbased and non-corrosive liquids, including lightweight lubricants, antifreeze, fuel oils, etc. Suction tube telescopes. Threaded for 2" or 1½" NPT bung. Removable spout threaded for 3/4" garden hose fitting.

- Dispenses approx. 1 gal. per 10 strokes
- For 15 to 55 gallon containers
- Weight: approx. 5 Lb.

PART# 10190

An easily operated pump with die-cast zinc alloy body, ideal for high viscosity liquids such as paraffin, gear oil, etc. Suction tube telescopes to fit various containers. Includes curved spout and high angle spout.

- Dispenses approx. 1 gal. per 4 strokes
- For 15 to 55 gallon containers
- Weight: approx. 7 Lb.

PART# 10120

A zinc-plated pail pump with steel and polyethylene parts for waxes, detergents and other non-corrosive liquids. Locking strap holds pump in place to adapt to a variety of pail openings.

- Dispenses approx. 1 gallon per 32 lift strokes
- For 5 & 6 gallon pails
- Weight: approx. 2 Lb.

ROTARY PUMPS

High Flow Gear Driven Rotary Pumps

Recommended For Diesel Fuel, Water Based Fluids & Most Alcohols

CHEMICALS

IMPORTANT! NOT intended for gasoline or benzyl

High Flow Gear Driven Rotary Pump



PART# 1009

Gear driven for fast and easy transfer of light oils, diesel, alcohol, antifreeze and windshield washer fluids

Features

- High flow Rotary Pump will empty a 55-gallon drum in approximately 2 minutes (25 GPM)

Specifications

Part #	1009	10250
Dispenses	1-gal. per 4 revolutions (25GPM)	1-gal. per 4 revolutions (25GPM)
Container	15-55 gal. drum	15-55 gal. drum
Construction	Aluminum Alloy	PPS
Vanes & Seals	Steel Vanes / NBR Seals	PTFE / FKM Seal
Bung Adapter	2" NPT Polyethylene	2" NPT Polyethylene
Suction Tube	3 pc. Steel (1.25" O.D.)	3 pc. Stainless Steel (1.25 O.D.)
Hose	54" Polypropylene (1009H)	54" Polypropylene (1009H)
Spout	1.25" x 16 Straight Thread	1.25" O.D. Stainless Steel

PART# 10250

Same as the 1009 but featuring a PPS construction, PTFE packing and a FKM seal for upgraded chemical resistance

ROTARY PUMPS

For Dispensing Chemicals From 15-55 Gal Drums

Recommended For Methanol, Chlorinated Solvents, Antifreeze & Windshield Washer Fluid



PART# 1014



PART# 1014R



PART# 10240

Rotary Pumps

Features

- Dispenses 1-gallon per 16 revolutions
- Lightweight and corrosion resistant
- Bung adapter (10217)
- 1" Hose barb
- 3/4" Outlet BSP
- 1" Inlet BSP
- 1.25" O.D. Pick up tube

Optional Accessory

- 46" Polyethylene ribbed hose (10213)



Specifications

Part #	Construction	Vanes	Seals	Gaskets	Recommended For
1014	Polypropylene	PPS	PTFE	Polyethylene	Petroleum products, water-based chemicals, and chlorinated solvents
1014R	PPS	PPS	FKM	PTFE	Aggressive chemicals, chlorinated solvents, aromatic and aliphatic hydrocarbons
10211	Polypropylene	PPS	FKM	Polyethylene	DEF, petroleum products, water-based chemicals, and chlorinated solvents
10255	Polypropylene	PTFE	PTFE	Polyethylene	Alcohols, petroleum products, water-based chemicals, and chlorinated solvents
10256	PPS	PTFE	PTFE	PTFE	Alcohols, chemicals, chlorinated solvents, aromatic and aliphatic hydrocarbons
10240	HDPE	PTFE	FKM	Polyethylene	Bleach, chlorine and other chemicals compatible with HDPE

PART# 10231

3 Vane PPS Rotary Pump

Smoother operation and higher flow than standard rotary pump.



Features

- Dispenses 1-gallon per 10 revolutions
- PPS construction
- Lightweight and corrosion resistant
- 1" Hose barb
- PTFE Vanes
- PTFE Seals
- Recommended for pumping aggressive chemicals including chlorinated solvents, aromatic and aliphatic hydrocarbons, etc.

CHEMICAL PUMPS

Lever Style Chemical Pumps
Made From Polyethylene, Polypropylene Or PPS

CHEMICALS

PART# 373

Plastic lever style pump for oil and water based products

**** IMPROVED DESIGN ****

Features

- Polypropylene, Polyethylene construction
- Acetal seal
- 3/4" x 6' hose included
- 3/4" hose barb outlet spout
- 2" bung adapter w/locking nut
- Fits 5 - 55-gallon drums
- Delivers 1-pint per stroke



Drum locking ring
For positioning
Pump outlet

PART# 374

Features

- Lightweight and corrosion resistant
- Dispenses maximum 12-oz. per stroke
- For 15-55-gallon drums
- Telescoping suction tube
- Bung adapter will fit 1 1/4" and 2" drum openings
- 1" O.D. Pick up tube



PART# 374



Specifications

Part #	Construction	Seal	Rod	Color	Recommended For
374	Polypropylene	FKM & Polypropylene	Plated Steel	Blue	Lubricants, Alcohol, Fuel Oils
375	Polypropylene	FKM & Polypropylene	Stainless Steel	Yellow	Water Based Fluid, Acid, Alkali Solutions
376	PPS	FKM & Polypropylene	Stainless Steel	Black	Stronger Acids, Alkali, 20% Nitric Acid
377	PPS	FKM & PTFE	Stainless Steel	Black	Stronger Acids, Alkali, Hexane, 20% Nitric Acid, Toluene, Toluol, Trichlorethane

PART# 170

Lever Lock



- Fits most lever style drum pumps
- Fits up to 1/2" locks
- Lock not included

PART# 375



PART# 376 & 377



CHEMICAL PUMPS

Lift Style & Siphon Style Pumps
Made From Polypropylene Or Nylon



PART# 369 (Individually Boxed)

- Fits 15-55 Gallon Container
- Siphons 7-gallons per minute
- Polyethylene (Body) & polypropylene (suction tube) construction
- Low density polyethylene discharge hose Part# 10112

Siphon Pump

Specifications

Part #.	Siphons Lower	Pumps Higher	Inlet	Outlet
369	Yes	Yes	1"	1"

PART# 10020 (24 Pumps in 1 box)

- Fits 15-55 Gallon Container
- Siphons 5-gallons per minute
- Polyethylene (Body) & polypropylene (suction tube) construction
- Spare discharge hose Part# 10113

PART# 10010 (120 Pumps in 1 box)

- Fits 1, 2 1/2 & 5 Gallon Container
- Siphons 2-gallons per minute
- Polyethylene (Body) & polypropylene (suction tube) construction

PART# 369 PART# 10020 PART# 10010

Also Available

PART# 369AR (24 Pumps in 1 box)

- Same as Part# 369
- Sold in bulk pack of 24



PART# 360, 363, 365

- Fits 15-55 Gallon Container
- Dispenses approx. 1-gallon per 8 lifts

Lift Style Pumps

Specifications

Part #.	Bung Adapter	Construction	Seal	Rod
360	Yes	Polypropylene	FKM	Nickel Plated Steel
363	Yes	Nylon	FKM	Nickel Plated Steel
365	Yes	Nylon	PTFE	Stainless Steel

PART# 360 PART# 363 PART# 365



PART# 10044



PART# 10050

PART# 10044

- Fits 15-55 Gallon Container
- Dispenses approx. 1-gallon per 16 lifts
- 5-gallon pail adapter included
- Recommended for water based fluids, light oils, mild acids soaps, detergents, waxes, deodorants, etc.

PART# 10050

- Fits 15-55 Gallon Container
- Dispenses approx. 1-gallon per 8 lifts
- 5-gallon pail adapter included
- Recommended for water based fluids, light oils, mild acids, soaps, detergents, waxes, deodorants, etc.

PART# 387

Features

- Stainless steel construction (316 alloy)
- Dispenses approx. 1-gal. per 8 lifts
- Fits 15 - 55-gallon drums
- PTFE packing and seals
- Polypropylene bung adapter

PART# 387



PART# 10110

PART# 10110

Features

- Stainless steel construction (316 alloy)
- Dispenses approx. 1-gal. per 16 lifts
- Fits 15 - 55-gallon drums
- PTFE packing and seals

PART# 11219

Features

- Stainless steel construction
- Dispenses approx. 1 gal. per 24 revolutions
- Fits 15, 30 and 55 gallon containers
- PTFE vanes and shaft seal
- Stainless steel bung adapter
- Stainless steel spring
- 3 pcs stainless steel pickup tube
- 3/4" Hose barb on spout
- Aluminum handle
- Rubber water deflector (WD950)



PART# 11219

PART# 10193

Features

- Stainless steel construction lever pump
- Dispenses approx. 1-gal. per 13 strokes
- Fits 15 - 55-gallon drums
- PTFE Seal



PART# 10193



PART# 1025

Air Operated 1:1 Double Diaphragm Pump

For transferring fluids at low pressure (*Not compatible with oil products*)

Maximum performance in a mini package; small enough to fit in your hand

Features

- Flow rate up to 6 GPM
- 6.5 CFM @ 100 PSI
- Polypropylene construction
- Santoprene seats and diaphragms
- Kynar check valve
- Hastelloy springs
- Maximum particle size .10" diameter
- 1/4" NPT air inlet
- 3/8" NPT inlet/outlet
- Non-stalling, Lube-free

RECOMMENDED ACCESSORY OPTIONS

- Air line filter with nighttime drain, regulator, gauge, ball valve and quick disconnects (1559A-ASSY)
- Wall mount bracket (96)



Split Intake Port

Split Intake Port

PART# 1035M

1/2" Split Inlet Mixing Pump (Flow rate 14 GPM)

For mixing 50% water and 50% antifreeze or windshield fluids

Features

- Polypropylene construction
- Buna N diaphragm
- Acetal balls, Poly. seats
- 1/2" NPT inlet / 1/2" NPT outlet



Combination Unit
1559A-ASSY

Suction Tube
15210



Oil Hose
2204



Air Hose
2004

PART# 1795

Air Operated 1:1 Fluid Pump (Flow rate 13 GPM)

For delivery of water based fluids

(Wetted parts constructed from non-corrosive material)

Features

- 29.06 CFM @ 100 PSI
- Tube length 24" PVC (15210)
- 2" NPT bung adapter
- 1/2" x 4-ft. oil hose (2204)
- 1/4" x 4-ft. air hose (2004)
- Air line filter with nighttime drain, regulator, gauge, ball valve and quick disconnects (1559A-ASSY)

For Various Containers

Pumps For Gasoline, Kerosene, Diesel, Light Oils, Tire Sealant, Antifreeze & Windshield Washer Fluid

PART# 7000

Cordless Multi-Purpose Pump

For pumping Gasoline, Kerosene, Diesel, Light Oils.

Features

- Operates on "D" size alkaline batteries X 2
- Flow rate up to 2.6 GPM
- Pumps approx. 1,056 gal. on two "D" size alkaline batteries
- Includes 39.4" long hose
- Suction tube length 15.2"

NEW
CORDLESS PUMP



PART# EFP-005

115-Volt AC Pump System for 55 gal drum

For pumping antifreeze & windshield washer fluid

Features

- Flow rate up to 5 GPM
- Pump length 40"
- Includes plastic nozzle (DEF-15)
- Included 2" NPT bung adapter (10217)
- Ideal alternative to slow, troublesome hand pumps
- 3/4" x 8' Vinyl Hose (2156)



PART# 240

Hand Operated Tire Sealant Pump

For pumping tire sealant directly into tubeless tires

Features

- For 5 to 6 1/2-gallon pails
- Dispenses approximately 1-gallon per 16 lift strokes
- Collar is adjustable allowing user to vary the length of each stroke and amount to be dispensed per stroke
- Return valve (240-115)
- 5-ft. vinyl hose (240-122)
- Powder coated cover
- Quick connect valve stem coupler (240-127)



PART# 9115

115 AC Diaphragm Pump

Features

- 9 -GPM
- Voltage 115 volts AC/ 3.5 amps
- 3/4 Hose barb inlet/outlet
- DEF kits available

Also available in 12 Volt (Part # 9112)



CHEMICAL RESISTANCE

Ratings-chemical effect

- No effect - Excellent
- Minor to Moderate effect - Fair
- Severe effect - Not recommended

Note:

Any pump used with a chemical not listed as Excellent is not covered by our warranty!

CHEMICAL NAME:	#360	#363	#365	#366T	#369AR	#373	#374	#375	#376	#377	#387	#753	#755	#757	#759	#761	#764	#798	#1014	#1014R	#10010	#10020	
Acetaldehyde																							
Acetic acid 20%																							
Acetic Anhydride																							
Acetone																							
Alcohol: Amyl																							
Alcohol: Benzyl																							
Alcohol: Butyl																							
Alcohol: Diacetone																							
Alcohol: Ethyl																							
Alcohol: Hexyl																							
Alcohol: Isobutyl																							
Alcohol: Isopropyl																							
Alcohol: Methyl																							
Alcohol: Propyl																							
Ammonia 10%																							
Ammonia, anhydrous																							
Ammonia, liquid																							
Ammonium Hydroxide																							
Anti-Freeze																							
Benzene																							
Benzoic Acid																							
Bleach																							
Boric Acid																							
Calcium Chloride (30% in Water)																							
Calcium Hypochlorite																							
Calcium Sulfate																							
Citric Acid																							
Copper Chloride																							
Copper Sulfate 5%																							
Detergents																							
Diesel Fuel																							
Ethyl Acetate																							
Ethylene Glycol																							
Formic Acid																							
Fuel Oils																							
Gasoline																							
Glycerin																							
Heptane (Brake Cleaner)																							
Hydrochloric Acid, to 37%																							
Hydrochloric Acid, to 50%																							
Hydrogen Peroxide, to 30%																							
Jet Fuel (JP3: JP4: JP5)																							
Kerosene																							
Lacquers																							
Lacquer Thinners																							
Lactic Acid																							
Methyl Ethyl Ketone																							
Mineral Spirits																							
Naphtha																							
Nitric Acid, to 20%																							
Oxalic Acid, (Cold)																							
Phosphoric Acid, to 40% solution																							
Photographic, (Developer)			N/A						N/A	N/A													
Potassium Chloride																							
Potassium Hydroxide																							
Propylene Glycol									N/A	N/A													
Silicone	N/A	N/A	N/A		N/A																	N/A	N/A
Sodium Bicarbonate																							
Sodium Chloride																							
Sodium Hydroxide 50%																							
Sodium Hypochlorite < 20%																							
Sodium Nitrate																							
Sodium Sulfate																							
Stoddard Solvent																							
Sulfuric Acid, 75%																							
Toluene, Toluol																							
Trichlorethane																							
Trichlorethylene																							
Turpentine																							
Urea/DEF																							
Xylene																							

!WARNING! The data for this chart has been gathered by other reputable sources. It should be used only as a guideline for selecting a pump. It is not an un-qualified guarantee of compatibility. Always test with your particular liquids and in the environment they will be exposed to. Assistance may be available from your dealer and/or National-Spencer Inc.. National-Spencer Inc. can assume no responsibility for the accuracy or completeness of this information for the specific applications. This chart reflects chemical resistance only. It does not take into consideration other properties of your liquids such as

1. Flammability
2. Viscosity
3. Tendency to dry, harden, thicken, foam or crystallize

The user is responsible for investigating these issues and taking appropriate safety precautions.

CHEMICAL RESISTANCE

Ratings-chemical effect

- No effect - Excellent
- Minor to Moderate effect - Fair
- Severe effect - Not recommended

Note:

Any pump used with a chemical not listed as Excellent is not covered by our warranty!

CHEMICAL NAME:	#10044	#10050	#10080	#10110	#10120	#10130	#10190	#10191	#10193	#10210	#10211	#10220	#10231	#10240	#10250	#10255	#10256	#11219	#7000	#7019
Acetaldehyde																				
Acetic acid 20%																				
Acetic Anhydride																				
Acetone																				
Alcohol: Amyl																				
Alcohol: Benzyl																				
Alcohol: Butyl																				
Alcohol: Diacetone																				
Alcohol: Ethyl																				
Alcohol: Hexyl																				
Alcohol: Isobutyl																				
Alcohol: Isopropyl																				
Alcohol: Methyl																				
Alcohol: Propyl																				
Ammonia 10%																				
Ammonia, anhydrous																				
Ammonia, liquid																				
Ammonium Hydroxide																				
Anti-Freeze																				
Benzene																				
Benzoic Acid																				
Bleach																				
Boric Acid																				
Calcium Chloride (30% in Water)																				
Calcium Hypochlorite																				
Calcium Sulfate																				
Citric Acid																				
Copper Chloride																				
Copper Sulfate 5%																				
Detergents																				
Diesel Fuel																				
Ethyl Acetate																				
Ethylene Glycol																				
Formic Acid																				
Fuel Oils																				
Gasoline																				
Glycerin																				
Heptane (Brake Cleaner)																				
Hydrochloric Acid, to 37%																				
Hydrochloric Acid, to 50%																				
Hydrogen Peroxide, to 30%																				
Jet Fuel (JP3: JP4: JP5)																				
Kerosene																				
Lacquers																				
Lacquer Thinners																				
Lactic Acid																				
Methyl Ethyl Ketone																				
Mineral Spirits																				
Naphtha																				
Nitric Acid, to 20%																				
Oxalic Acid, (Cold)																				
Phosphoric Acid, to 40% solution																				
Photographic, (Developer)																				
Potassium Chloride																				
Potassium Hydroxide																				
Propylene Glycol																				
Silicone															N/A					
Sodium Bicarbonate																				
Sodium Chloride																				
Sodium Hydroxide 50%																				
Sodium Hypochlorite < 20%																				
Sodium Nitrate																				
Sodium Sulfate																				
Stoddard Solvent															N/A					
Sulfuric Acid, 75%																				
Toluene, Toluol																				
Trichlorethane																				
Trichlorethylene																				
Turpentine																				
Urea/DEF																				
Xylene																				

!WARNING! The data for this chart has been gathered by other reputable sources. It should be used only as a guideline for selecting a pump. It is not an un-qualified guarantee of compatibility. Always test with your particular liquids and in the environment they will be exposed to. Assistance may be available from your dealer and/or National-Spencer Inc.. National-Spencer Inc. can assume no responsibility for the accuracy or completeness of this information for the specific applications. This chart reflects chemical resistance only. It does not take into consideration other properties of your liquids such as

1. Flammability
2. Viscosity
3. Tendency to dry, harden, thicken, foam or crystallize

The user is responsible for investigating these issues and taking appropriate safety precautions.

Part Number Index

Part No.	Description	Page	Ship Wt.	UPC No.
A-101	Flange adapter	93	0.1	0 1595440099 8
A-102	Threaded adapter 1" NPT (M)	93	0.1	0 1595440103 2
A-103	Threaded adapter 3/4" NPT (M)	93	0.1	0 1595440115 5
A-104	Bayonet adapter	93	0.3	0 1595440105 6
BOWL	Replacement filter bowl for NS-10	70	1.0	0 1595400009 9
D01	Non-drip attachment for barrel pumps	26	0.1	0 1595400002 0
D-100	Disposable breather w/ silica gel 3.5" height x 5" diameter	93	2.0	0 1595440100 1
D-101	Disposable breathe rw/ silica gel 5" height x 5" diameter	93	3.0	0 1595440101 8
D-102	Disposable breather w/ silica gel 8" height x 5" diameter	93	4.0	0 1595440102 5
D-108	Disposable breather w/ silica gel 10" height x 5" diameter 2" NPT (M)	93	6.0	0 1595440122 3
D-109	Disposable breather w/ silica gel 14" height x 6" diameter 3" NPT (M)	93	7.0	0 1595440124 7
D-S	Drum pump w/o hose for 15-55 gallon drum	26	5.0	0 1595400001 3
D-S1	Drum pump w/ non-drip attachment	26	5.0	0 1595400011 2
DEF-005	115-volt DEF complete pump system for 55 gallon container 5-GPM	67	14.0	0 1595440961 8
DEF-005EC	115-Volt DEF Pump System	67	16.0	0 1595440970 0
DEF-010	115-volt DEF complete pump system for 275 gallon container 5-GPM	67	16.0	0 1595440962 5
DEF-010EC	115-Volt DEF complete economy pump system for 275 gal container 5-GPM	67	17.0	0 1595440972 4
DEF-020EC	DEF economy pump for 330 gallon tote.5-GPM	67	18.0	0 1595440974 8
DEF-027EC	DEF economy pump for a 55 gallon drum.10-GPM	67	21.00	0 1595440971 7
DEF-028EC	DEF economy pump for 275 gallon tote. 10-GPM	67	25.0	0 1595440975 5
DEF-15	Plastic Manual Nozzle	64	21.0	0 1595440964 9
DEF-504G	Digital DEF nylon meter w/ 1" inlet/outlet & 3/4" bushing	67	2.0	0 1595431511 7
DEF-601	Polypropylene cam lock coupler with 3/4" hose barb and EPDM seals	68	2.0	0 1595440980 9
DEF-906	Stainless steel Automatic Nozzle	64	7.0	0 1595440977 9
DEF-7925	25x3/4" NPT Hose - 250 PSI	77	47.0	0 1595440978 6
DEF- 107233	3/4" Hose Barb X 3/4" NPY SS Swivel	64	1.0	0 1595440981 6
EFP-005	115-volt chemical & water-base fluid pump for 55 gallon container	101	12.0	0 1595440960 1
HD4	Heavy-duty powder-coated grease gun w/ rigid pipe	53	5.0	0 1595410005 8
HD4A	Heavy-duty powder-coated grease gun w/ 12" hose	53	5.0	0 1595410020 1
HD4ACTB	HD4A w/ blue aluminum rings on end of clear tube	55	5.0	0 1595454020 5
L30-94N	Tank brace for 30A1 diaphragm pump	69	3.0	0 1595453094 7
L30-95N	8' rubber hose for diaphragm pump 3/4" NPT (M)	75	3.0	0 1595453095 4
L30-99N	Telescoping suction tube w/ foot valve	26	2.0	0 1595453097 8
NS-CTB	Clear tube w/ blue aluminum rings on each end	55	1.0	0 1595454000 7
NS-10	Fuel tank filter 1" NPT	70	2.0	0 1595400010 5
NS-10-BSP	Fuel tank filter w/ BSP thread 1" BPT	70	2.0	0 1595400008 2
NS-10W	Fuel filter w/ water separating element 1" NPT	70	2.0	0 1595400007 5
NS-30	Spin on fuel filter w/10 micron filter cartridge	70	2.5	0 1595400030 3
NS-30AR	Aluminum casting fuel filter head	70	2.5	0 1595400031 0
NS-40	Replacement 10 micron filter	70	1.5	0 1565400040 2
NS-40WB	Replacement 10 micron water block filter	70	1.5	0 1595400041 9
OMS900524E	Wireless oil management system keypad + one meter	10	12.0	0 1595449005 5
PW005	5 gallon parts washer, solvent capacity 3 1/2 gallons	80	9.0	0 1595440005 9
PW020	20 gallon parts washer, solvent capacity 12 gallons	80	3.0	0 1595440020 2
S-154	Disposable breather w/ silica gel 5" height x 5: diameter 1" NPT	93	3.0	0 1595440126 1
Z-131	Mini breather 1 3/4" ht. X 2" diameter	93	0.2	0 1595440131 5
Z-132	Mini breather 3" ht. X 2" diameter	93	0.2	0 1595440132 2
Z-133	Mini breather 1 3/4" ht. X 3 1/4" diameter	93	0.3	0 1595440133 9
Z-134	Mini breather 3" ht. X 3 1/4" diameter	93	0.3	0 1595440134 6
08DEF750	DEF Hose 3/4" id	67	0.3	0 1595440979 3
10	10" steel adapter tube for grease guns 1/8" NPT (M)	60	0.2	0 1595410010 2
11SP	Rigid Flexible Extension	58	1.0	0 1595420011 6
12G	12" thermoplastic-covered whip hose	58	1.0	0 1595410111 6
12R	12" rubber-covered wire-braid whip hose	58	0.3	0 1595410112 3
12R-1	12" rubber-covered wire-braid whip hose - Poly bag	58	0.3	0 1595410114 7
12R-SP	12" rubber-covered wire-braid whip hose - Blister pack	58	0.3	0 1595420013 0
13R	12" rubber-covered 2 wire-braid whip hose	58	0.3	0 1595410113 0
15-30	Drum pump w/ 5' hose for 15 or 30 gallon drum	29	8.0	0 1595401530 7
17	Whip hose assembly w/ coupler & adapter for 1536A control handle	41	0.4	0 1595410017 1
18G	18" thermoplastic-covered whip hose	58	1.0	0 1595410118 5
18R	18" rubber-covered wire-braid whip hose	58	0.4	0 1595410119 2
18R-1	18" rubber-covered wire-braid whip hose - Poly bag	58	0.4	0 1595410120 8
18R-SP	18" rubber-covered wire-braid whip hose - Blister pack	58	0.4	0 1595420019 2
18RR	18" rubber-covered 2 wire-braid whip hose	58	0.4	0 1595410121 5
19G	24" thermoplastic-covered whip hose	58	1.0	0 1595410123 9
19R	24" rubber-covered wire-braid whip hose	58	0.4	0 1595410124 6
19R-SP	24" rubber whip hose - Blister pack	58	1.0	0 1595420020 8
20	Replacement element for NS-10 filter	70	1.0	0 1595400020 4
20WB	Water separating element for NS-10	70	1.0	0 1595400021 1
22	Needle adapter to lubricate bearings 1/8" NPT (F)	60	0.1	0 1595410022 5
23	Seal-off adapter to lubricate bearings 1/8" NPT (F)	60	0.1	0 1595410023 2
24	Coupler connector to connect hose to grease gun 1/8" NPT (F)	60	0.1	0 1595410024 9
25	Heavy-duty hydraulic coupler w/ ball check 1/8" NPT (F)	59	0.2	0 1595410025 6
25SP	Heavy-duty hydraulic coupler w/ ball check 1/8" NPT (F) skin pack	59	0.2	0 1595420025 3
26	Manual non-drip tip	14	0.1	0 1595440026 4
26A	Automatic non-drip tip	14	0.5	0 1595440027 1
27	4-jaw hydraulic coupler 1/8" NPT (F)	59	0.1	0 1595410027 0
27SP	4-jaw hydraulic coupler 1/8" NPT (F) skin pack	59	0.1	0 1595420027 7

Part Number Index

Part No.	Description	Page	Ship Wt.	UPC No.
28	Standard 3-jaw hydraulic coupler w/ ball check 1/8" NPT (F)	59	0.1	0 1595410028 7
28SP	Standard 3-jaw hydraulic coupler w/ ball check 1/8" NPT (F) skin pack	59	0.1	0 1595420028 4
29	Valve for grease gun filler pumps 1/4" NPT (F)	60	0.1	0 1595410029 4
30A1	Diaphragm pump w/ 8' hose, plain nozzle & suction tube	69	13.0	0 1595400301 4
31	Standard button head coupler 1/8" NPT (F)	60	0.1	0 1595410031 7
32	Giant button head coupler 1/8" NPT (F)	60	0.2	0 1595410032 4
33	14-1/2 oz. multi-purpose lithium grease cartridge	51	1.0	0 1595410033 1
35	Bag of 3 - 3 oz. tubes of multi-purpose lithium grease	48	1.0	0 1595410035 5
36	Drum pump hose w' garden hose thread 5' long x 1/2" ID (F)	75	0.8	0 1595450036 0
36R	36" rubber-covered wire braid whip hose	58	1.0	0 1595410043 0
36R-SP	36" rubber-covered wire-braid whip hose skin pack	58	1.0	0 1595420036 9
43	Heavy-duty filter wrench for standard filters	86	0.6	0 1595430043 4
44	Heavy-duty 3-jaw coupler (7500 psi)	59	0.1	0 1595410044 7
45	Chain-type filter wrench for diameters up to 4-1/2"	86	0.4	0 1595430045 8
47SP	Right-angled hydraulic coupler	59	0.5	0 1595420047 5
48	360° swivel coupler for grease guns 1/8" NPT (M)	59	0.3	0 1595410048 5
48SP	360° swivel coupler for grease guns 1/8" NPT (M) skin pack	59	0.4	0 1595420048 2
52	360° swivel coupler w/ 45° locking positions	59	0.3	0 1595410052 2
52SP	360° swivel coupler w/ 45° locking positions skin pack	59	0.3	0 1595420052 9
55	5 1/2" curved steel grease pipe 1/8" NPT (M)	60	0.1	0 1595410055 3
57	Manual cast-iron gate valve threaded 1" NPT	84	2.0	0 1595430057 1
63	Manual cast-iron gate valve threaded 3/4" NPT	84	1.5	0 1595430063 2
64	Manual cast-iron gate valve threaded 2" NPT	84	4.0	0 1595430064 9
65	Hypodermic needle adapter for sealed bearings	60	0.1	0 1595410065 2
67	Polyethylene bung faucet for 2" NPT opening	84	0.6	0 1595430067 0
68	Polyethylene bung faucet for 3/4" NPT opening	84	0.1	0 1595430068 7
80	Loader nipple for grease gun or filler pump 1/8" NPT (M)	60	0.1	0 1595410080 5
80SP	Loader nipple for grease gun or filler pump 1/8" NPT (M) skin pack	51	0.1	0 1595420080 2
81	Die-cast bung faucet for steel drum or barrel 3/4" NPT	84	0.4	0 1595430081 6
86	Transmission funnel w/ screen & 14" flexible metal spout	87	0.5	0 1595430086 1
88	Drum pump hose w/ garden hose thread & curved nozzle 8' x 1/2"	75	2.0	0 1595450088 9
89	2" aluminum drum tap w/ polypropylene plunger	84	1.0	0 1595430089 2
91	Wall mount kit for stub-style pump 2" NPT	14	5.0	0 1595440091 2
92	Suction kit for wall mounted stub pump 3/4" NPT	14	10.0	0 1595440092 9
93	6 oz. pump-action oiler w/ 6" rigid & flexible spout	90	0.4	0 1595430093 9
94	1 pint pump-action oiler w/ 6" rigid & flexible spout	90	0.5	0 1595430094 6
95	10 oz. pump-action oiler w/ 6" rigid & flexible spout	90	0.7	0 1595430095 3
96	Wall mount for air-operated double-diaphragm pump	5	3.0	0 1595440096 7
97	1 quart pump-action oiler w/ 6" rigid & flexible spout	90	0.6	0 1595430097 7
98	Double diaphragm pump adapter	5	8.0	0 1595440098 5
101	Suction gun w/ 12" vinyl hose	27	2.0	0 1595410101 7
103	Transfer pump w/ 8' clear vinyl hose	69	2.0	0 1595410103 1
105	Band-type dolly w/ phenolic casters for 25-50 lb. pail	83	5.0	0 1595430105 9
105-S	Band-type dolly w/ steel casters for 25-50 lb. pail	83	5.0	0 1595430106 6
108-5110	Container for vacuum pump (p/n 1785)	6	6.0	0 1595445110 5
120	Band-type dolly w/ phenolic casters for 100-120 lb. drum	83	6.0	0 1595430120 2
120-S	Band-type dolly w/ steel casters for 100-120 lb. drum	83	6.0	0 1595430121 9
130-S	Band-type dolly w/ steel casters for 30 gallon drum	83	9.0	0 1595430131 8
135	Tilting drum cradle w/ wheels	83	26.0	0 1595430135 6
135WC	Tilting drum cradle w/ casters	83	26.0	0 1595430132 5
137	Tilting drum cradle w/o wheels	83	23.0	0 1595430137 0
138-S	Lip-type dolly w/ steel casters for 55 gallon drum	83	14.0	0 1595430138 7
140-S	Band-type dolly w/ steel casters for 55 gallon drum	83	26.0	0 1595430140 0
140-SOR	Out-rigger band-type drum dolly w/ steel casters for 55 gallon drum	83	32.0	0 1595430141 7
145	Hand truck w/ drum chain & 6" rubber tires 450 lb. capacity	82	15.0	0 1595430145 5
147	Adjustable cart for 16-120 lb. drum	82	13.0	0 1595430147 9
148	4-wheel cart for 55 gallon drum	82	85.0	0 1595430148 6
149	Clamp style grease gun holder	53	0.4	0 1595410149 9
149SP	Clamp style grease gun holder skin pack	53	0.4	0 1595420149 6
150	3-wheel drum cart for 55 gallon drum	82	35.0	0 1595430150 9
151	2" polypropylene buttress thread adapter	81	0.2	0 1595430151 6
155	Drum pump w/ 5' hose for 15-55 gallon oil drum	29	8.0	0 1595400155 3
159	Extra secure grease gun mount ideal for truck mounting	53	4.0	0 1595410150 5
160	Pump for non-corrosive fluids. Fits container up to 2 1/2 gallons	101	0.5	0 1595400160 7
167	Universal spoke drum wrench	81	3.0	0 1595430167 7
169	Aluminum plug wrench for 3/4" & 2" drum plug	81	0.5	0 1595430169 1
170	Safety lock for lever action pump	26	0.1	0 1595400170 6
175	Filter Wrench	70	2.0	0 1595430175 2
180	Mini grease gun for bulk or 3 oz. cartridge	48	2.0	0 1595410180 2
180G	Mini grease gun w/ 3 oz. cartridge	48	3.0	0 1595410181 9
186	Hand operated grease fitting cleaner for unstopping clogged grease fittings	54	4.0	0 1595410186 4
202	Drum pump for E-85 & Biodiesel fuels	69	5.0	0 1595400202 4
227	18 gallon heavy-duty steel lowboy drain	34	49.0	0 1595430228 5
234	17 gallon lowboy drain w/ 2 wheels, 2 casters & handle 8"x25"x46"	34	50.0	0 1595430234 6
236	Evacuation kit for lowboy drain (fittings, pump & hose)	34	9.0	0 1595430236 0
237	17 gallon lowboy drain w/ 2 casters, 2 wheels, handle & pump	34	55.0	0 1595430237 7
240	Tire sealant pump w/ hose, coupler & cover for 5 - 6 1/2 gallon pail	101	7.0	0 1595400240 6
306	6 gallon foot-operated oily waste can. FM & UL listed	80	10.0	0 1595430306 0

Part Number Index

Part No.	Description	Page	Ship Wt.	UPC No.
309	8 gallon portable lift drain w/o wheels	33	30.0	0 1595430309 1
310	10 gallon foot-operated oily waste can. FM & UL listed	80	12.0	0 1595430310 7
312	Waste oil lift drain for use w/ 120 lb. open drum	33	16.0	0 1595430312 1
316	8 gallon portable lift drain w/ 3 1/2" wheels	33	30.0	0 1595430316 9
318	18 gallon portable lift drain w/ 3 1/2" wheels	33	30.0	0 1595430318 3
321	Lube pump w/ 4' hose for 5 - 6 1/2 gallon pail	27	8.0	0 1595400321 2
327	Filler pump w/ follower plate for 120 lb. open drum	45	10.0	0 1595400327 4
328	Filler pump w/ follower plate for 25-50 lb. pail	45	8.0	0 1595400328 1
331	Bearing packer w/ lever grease gun & gun holder	44	9.0	0 1595400331 1
333	Bearing packer w/ follower plate for use w/ 25-50 lb. pail	44	10.0	0 1595400333 5
336	Lube pump w/ 5' hose for 16 gallon drum	29	10.0	0 1595400336 6
338	Pump w/o hose for 16 gallon drum	29	8.0	0 1595400338 0
343	Bearing packer w/ follower plate for 120 lb. drum	44	12.0	0 1595400343 4
353	Plastic Hand pump for pull-up spout hose & spout	27	3.0	0 1595400354 0
360	Polypropylene pump w/ nickel-plated rod w/o hose 15-55 gallon	98	1.5	0 1595400360 1
363	Nylon pump w/ nickel-plated rod w/ hose 15-55 gallon	98	1.5	0 1595400363 2
365	Nylon pump w/ stainless-steel rod w/o hose 15-55 gallon	98	1.5	0 1595400365 6
366	Barrel pump w/ red bung adapter w/o hose for 15-55 gallon drum	28	5.0	0 1595400366 3
366T	Barrel pump w/ bung adapter w/o hose for 15-55 gallon drum	28	5.0	0 1595400367 0
369	Polyethylene siphon pump w/ hose for 15-55 gallon drum	98	2.0	0 1595400369 4
369AR	Polyethylene siphon pump w/ hose for 15-55 gallon drum - bulk pack	98	2.0	0 1595400370 0
373	Glass-filled nylon lever handle piston pump for 5-55 gallon drum	97	4.0	0 1595400373 1
374	Polypropylene & steel construction chemical pump w/ FKM seals	97	2.5	0 1595400374 8
375	Polypropylene & stainless-steel chemical pump w/ FKM seals	97	2.5	0 1595400380 9
376	PPS & stainless-steel chemical pump w/ FKM seals	97	2.5	0 1595400376 2
377	PPS & stainless-steel chemical pump w/ PTFE seals	97	2.5	0 1595400377 9
381	Barrel pump w/o hose for 15-55 gallon drum	26	5.0	0 1595400381 6
382	Barrel pump w/ non-drip tip for 15-55 gallon drum	26	5.0	0 1595400382 3
387	Stainless-steel lift pump for 15-55 gallon drums w/ PTFE seals	99	4.0	0 1595400387 8
410	3-way loading lever-style grease gun w/ pipe	52	4.0	0 1595410410 0
413	3-way loading lever-style grease gun w/ whip hose	52	4.0	0 1595410413 1
414	3-way loading lever-style grease gun w/ whip hose	51	3.0	0 1595410414 8
415	3-way loading chrome-plated lever-style grease gun w/ pipe	51	3.0	0 1595410415 5
419	3-way loading powder-coated lever-style grease gun	52	4.0	0 1595410419 3
420	3-way loading powder-coated lever-style grease gun w/ 12" whip hose	52	4.0	0 1595410422 3
444	3-way loading powder-coated lever-style grease gun	51	4.0	0 1595410444 5
514	Plastic-coated chemical-resistant industrial gloves	80	0.6	0 1595430514 9
540	Hand-operated grease pump w/ 22 lb. fully enclosed container	43	22.0	0 1595400540 7
550	Hand-operated grease pump w/ follower plate for 25-50 lb. pail	43	11.0	0 1595400550 6
567	Hand-operated grease pump w/ hose & follower plate for 25-50 lb. pail	43	12.0	0 1595400567 4
609	Adjustable stroke grease gun with 18" whip hose & coupler	50	4.0	0 1595410607 4
610	3-way loading pistol-style grease gun w/ pipe	49	4.0	0 1595410610 4
613	3-way loading pistol-style grease gun w/ whip hose	49	4.0	0 1595410613 5
615	3-way loading pistol-style grease gun w/ pipe	50	3.0	0 1595410615 9
619	Pistol-style powder-coated grease gun w/ pipe	49	4.0	0 1595410619 7
620	Pistol-style powder-coated grease gun w/ whip hose	49	4.0	0 1595410620 3
620CTB	620 w/ blue aluminum rings on clear tube	55	4.0	0 1595454040 3
625	Bench type bearing packer for bearings up to 6"	44	3.0	0 1595400625 1
660	Kit including an assortment of quick connect lube accessories	54	1.0	0 1595400661 9
699J	Universal 18" replacement funnel for 1 1/2" to 1 7/8" ID tube	88	1.5	0 1595430699 3
701	1 quart galvanized funnel w/ screen	87	0.4	0 1595430701 3
703	8 quart lock-on galvanized funnel w/ screen & 1" outlet	87	2.2	0 1595430703 7
705	5 quart offset galvanized funnel w/ screen & 1" outlet	87	1.7	0 1595430705 1
707	3 quart galvanized funnel w/ screen	87	2.0	0 1595430707 5
721	3 1/2 galvanized utility drain	87	2.0	0 1595430721 1
731	6-liter measure for oil, antifreeze, & windshield fluid	91	1.0	0 1595430731 0
732	8-liter measure for oil, antifreeze, & windshield fluid	91	2.0	0 1595430732 7
737	Battery filler	91	1.0	0 1595430737 2
743	4 quart powder-coated flow-control measure w/ flexible metal spout	90	4.0	0 1595430743 3
745	5 quart powder-coated flow-control measure w/ flexible metal spout	90	5.0	0 1595430745 7
748	8 quart flow-control measure w/ flexible metal spout	90	6.0	0 1595430748 8
751	1 quart polyethylene measure w/ flexible spout	91	0.2	0 1595430751 8
752G	Replacement lid for 751 measure	91	0.3	0 1595431502 5
753	2 quart polyethylene measure w/ flexible spout	91	0.3	0 1595430753 2
754G	Replacement lid for 753 & 755 measure	91	0.3	0 1595431503 2
755	3 quart polyethylene measure w/ flexible spout	91	0.5	0 1595430755 6
757	5 quart polyethylene measure w/ flexible spout	91	0.6	0 1595430757 0
758G	Replacement lid for 757 measure	91	0.3	0 1595441033 1
759	6" heavy-duty polyethylene funnel w/ screen	89	0.3	0 1595430759 4
760	6 quart polyethylene measure w/ flexible spout	91	0.5	0 1595400031 0
761	9" heavy-duty polyethylene funnel w/ screen	89	0.6	0 1595430761 7
764	Heavy-duty polyethylene funnel w/ screen for diesel 10" x 7" top	89	0.9	0 1595430764 8
765	Parts cleaner & drain pan	87	1.5	0 1595430765 5
766	Antifreeze drain pan 16 liter	87	2.0	0 1595430767 9
769	3 quart polyethylene drum funnel threaded for 2" NPT opening	88	3.0	0 1595430769 3
770	Deluxe plastic funnel w/ 11" flexible outlet	89	0.3	0 1595430770 9
772	Polyethylene drum funnel for 55 gallon drum	88	4.0	0 1595430772 3
774	Plastic cover for 772 drum funnel	88	5.0	0 1595430774 7

Part Number Index

Part No.	Description	Page	Ship Wt.	UPC No.
775	King size plastic funnel 4 1/2" x 17"	89	0.4	0 1595430775 4
776	Drain pan 24" x 24"	88	1.0	0 1595430776 1
778	Drain pan 24" x 37"	88	3.0	0 1595430778 5
782	Spill containment platform for 2 - 55 gallon drums	85	32.0	0 1595430782 2
783	Ramp for 2 & 4 drum spill containment platforms	85	32.0	0 1595430783 9
784	Spill containment platform for 4 - 55 gallon drums	85	67.0	0 1595430784 6
784L	4 in line drum containment platform	85	67.0	0 1595430795 2
785	Aluminum drip pan	87	2.0	0 1595430785 3
786	Oil meter holder w/ drip tray	14	20.0	0 1595430786 0
790	32 oz. disposable fast funnel	89	1.5	0 1595430790 7
791	8.5 oz. disposable fast funnel	89	1.0	0 1595430791 4
794	Graffiti remover - quart spray bottle	92	3.0	0 1595430794 5
794-G	Graffiti remover - gallon bottle	92	9.0	0 1595430800 3
794-5G	Graffiti remover - 5 gal container	92	50.0	0 1595430801 0
794-55G	Graffiti remover - 55 gal container	92	56.0	0 1595430802 7
796	Dyna-wipes disposable cleaning towels - qty 80 towels	92	3.0	0 1595430796 9
796-25	Dyna-wipes disposable cleaning towels - qty 30 towels	92	0.9	0 1595420803 1
796-120	Dyna-wipes disposable cleaning towels - qty 120 towels	92	4.3	0 1595430803 0
796-25P	Painter wipes disposable cleaning towels - qty 30 towels	92	0.9	0 1595430805 4
796-PMG	Purple Magic industrial cleaner - 1 gallon	92	9.0	0 1595430806 5
796-PMQ	Purple Magic industrial cleaner - 1 quart	92	3.0	0 1595420807 5
798	Funnel w/ lid	88	2.0	0 1595430798 3
799	2 gallon E-Z Smart Funnel	88	5.0	0 1595430799 0
830	Horizontal drum vent for 2" NPT	81	1.0	0 1595430830 0
911	Air-operated grease gun w/ swivel	47	4.0	0 1595410911 2
912-19	19-volt battery-operated grease gun w/ charger, 2 batteries & case	46	18.2	0 1595410915 0
912-19L	19 volt lithium battery operated grease gun	46	14.0	0 1595410924 2
912-19LK	Lithium battery kit for 912-19	46	2.0	0 1595410921 1
913	Drop light on 20' retractable electric cord reel	79	4.0	0 1595440913 7
914	Continuous-flow air-operated grease gun	47	4.0	0 1595410914 3
916	Fluorescent light on 40' cord reel	79	12.0	0 1595440916 8
918	Drop light on 50' retractable cord reel	79	9.0	0 1595440918 2
924	Dual-voltage portable oil pump 12 & 24 DC	62	23.0	0 1595440924 3
925	12V DC 15 GPM Fuel Pump	61	3.2	0 1595440925 0
926	12-volt UL listed fuel pump w/ 10' hose 13 GPM	62	31.0	0 1595440926 7
927	110/115-volt UL listed fuel pump w/ 10' hose 13 GPM	62	31.0	0 1595440927 4
928	12-volt fuel pump w/ 12' hose 13 GPM	63	24.0	0 1595440928 1
930	115V AC 15 GPM Fuel Pump	61	3.2	0 1595440930 4
933	115-volt AC fuel pump w/ 12' hose 12 GPM	63	20.0	0 1595440933 5
936G	115-volt AC oil pump 4.4 GPM	22	58.0	0 1595440945 8
938G	115-Volt AC oil pump / high flow 8 GPM	22	33.9	0 1595440950 2
942	12-volt fuel pump w/ 12' hose (high flow 20 GPM)	62	37.0	0 1595440942 7
945	12V DC 20 GPM Fuel Pump	61	21.0	0 1595440925 2
960	Economy rotary pump for 15-55 gallon container	71	14.0	0 1595400960 3
961	Economy rotary pump w/ rubber hose & holster for 15-55 gallon	71	18.0	0 1595400961 0
962	Economy rotary pump w/ telescoping tube for 15-55 gallon	71	13.0	0 1595400962 7
963	Economy rotary pump w/ telescoping tube, hose & holster	71	18.0	0 1595400963 4
975	Quart stroke pump for 15-55 gallon container	25	13.0	0 1595400975 7
1000R	Power coated steel sprayer features	90	3.0	0 1595310006 9
1002	Rotary hand pump for 15-55 gallon container	72	13.0	0 1595401002 9
1003	Rotary hand pump w/ hose & nozzle cover for 15-55 gallon	72	18.0	0 1595401003 6
1006	3 vane rotary hand pump	73	20.0	0 1595401006 7
1006H	3 vane rotary hand pump w/ hose & nozzle	73	22.0	0 1595401005 0
1006HFM	FM approved 3 vane rotary hand pump w/ hose & nozzle	73	22.0	0 1595401004 3
1007	Heavy-duty multi-directional rotary pump	73	23.0	0 1595401007 4
1007H	Heavy-duty multi-directional rotary pump w/ 2158 hose	73	25.0	0 1595401008 1
1009	High flow gear driven rotary pump	95	13.0	0 1595401009 8
1014	Plastic rotary pump	96	5.0	0 1595401014 2
1014R	PPS plastic rotary pump	96	5.0	0 1595401015 9
1025	Air-operated polypropylene double-diaphragm pump 1/4" NPT 4.5 GPM	100	3.0	0 1595441025 6
1035	Air-operated polypropylene double-diaphragm pump 1/2" NPT 14 GPM	3	9.0	0 1595441035 5
1035K	Polypropylene double diaphragm pump w/ suction kit for oil 1/2" NPT 14 GPM	5	21.0	0 1595441036 2
1035K2	Double-diaphragm suction kit for 227 truck drainer	5	21.0	0 1595431504 9
1035M	Double-diaphragm mixing pump 1/2" NPT 14-GPM	100	9.0	0 1595441034 8
1035SP	Air-operated double diaphragm pump w/ santoprene 1/2" NPT	67	9.0	0 1595441031 7
1037	Polypropylene fluid evacuation pumping system 1/2" NPT 14 GPM	3	13.0	0 1595441037 9
1038	Air-operated aluminum double-diaphragm pump 3/4" NPT	3	10.0	0 1595441032 4
1040	Air-operated aluminum double-diaphragm pump 3/4" NPT x 1" NPT 37 GPM	3	22.0	0 1595441040 9
1040K	37-GPM double-diaphragm pump w/ a suction kit for waste oil 1"	5	52.0	0 1595441039 3
1040SS	Stainless-steel double-diaphragm pump 1" NPT w/ PTFE	3	42.0	0 1595441045 4
1040UL	Aluminum double-diaphragm pump 1" NPT 37 GPM	3	22.0	0 1595441041 6
1041	Aluminum double-diaphragm pump 1 1/2" NPT 72 GPM	4	60.0	0 1595441042 3
1043	Aluminum double-diaphragm pump 2" NPT 155 GPM	4	70.0	0 1595441043 0
1044	Aluminum double-diaphragm pump 3" NPT 230 GPM	4	115.0	0 1595410044 7
1101	Swivel adapter for oil meter 1/2" (M) x 1/2" (F) NPT	14	0.4	0 1595431101 0
1183	1/4" nipple fitting	74	1.0	0 1595431183 6
1208	Gear lube pump w/ meter, hose, dolly & cover for 16 gallon drum	24	24.0	0 1595401208 5
1209	Gear lube pump w/ hose, dolly & cover for 16 gallon drum	24	16.0	0 1595401209 2

Part Number Index

Part No.	Description	Page	Ship Wt.	UPC No.
1209RAR	Gear lube pump only	24	7.0	0 1595401229 0
1212A	55:1 stationary grease pump for 400 lb. drum	40	55.0	0 1595441229 8
1212R	60:1 stationary grease pump for 400 lb. drum	40	43.0	0 1595441234 2
1213A	60:1 portable grease pump w/ 6' hose for 120 lb. drum	39	41.0	0 1595441223 6
1213R	60:1 ratio portable grease system for 120 lb. drum (6' hose)	37	45.0	0 1595441226 7
1214A	55:1 stationary grease pump for 120 lb. drum	39	22.0	0 1595441224 3
1220R	50:1 ratio portable grease system for 120 lb. drum (6' hose)	38	38.0	0 1595441232 8
1230	20 gallon oil evacuation unit	31	102.0	0 1595441230 4
1231	20 gallon oil evacuation unit w/ funnel	31	96.0	0 1595441231 1
1234	21 gallon steel lift drain	33	75.0	0 1595441254 0
1235	17 gallon waste oil drain	30	74.0	0 1595441235 9
1236	24 gallon waste oil drain	30	82.0	0 1595441236 6
1315	Fluid flex hose for oil meter	14	0.5	0 1595441315 8
1315A	Fluid flex hose w/ non-drip nozzle for oil meter	14	0.6	0 1595441316 5
1326	16" 90° pipe w/ manual non drip nozzle	14	0.8	0 1595441326 4
1330	8" 30° bent rigid pipe w/ non-drip nozzle for oil meter	14	0.5	0 1595441330 1
1335	8" 15° bent rigid pipe w/ non-drip nozzle for oil meter	14	0.5	0 1595441335 6
1340	6" straight pipe w/ automatic non-drip nozzle for oil meter	14	0.4	0 1595441340 0
1440R	52' open-type dual-arm grease hose reel	76	44.0	0 1595441490 2
1444R	49' open-type oil hose reel	76	44.0	0 1595441494 0
1448R	49' open-type air/water hose reel	76	44.0	0 1595441498 8
1456R	39' open-type air/water hose reel	76	31.0	0 1595441496 4
1458NS	3/8" x 50' air/water hose reel 300 psi	77	29.0	0 1595442458 1
1458R	59' open type air/water hose reel	76	38.0	0 1595441497 1
1459	33' enclosed plastic air/water hose reel	78	14.5	0 1595441459 9
1470NS	100' discharge cable	78	22.0	0 1595441504 6
1472NS	50' in closed static discharge cable reel	78	12.0	0 1595441505 3
1474R	1/4" x 39' grease hose reel	76	36.0	0 1595441493 3
1475R	1/2" x 32' oil hose reel	76	38.0	0 1595441495 7
1476NS	45' reel w/ GFI duplex outlet box	79	41.0	0 1595441476 6
1477NS	50' reel w/ fluorescent light & outlet	79	37.0	0 1595441477 3
1481NS	3/4" x 50' fuel hose reel	76	91.0	0 1595441481 0
1482NS	1" x 50' fuel hose reel	76	95.0	0 1595441482 7
1496NS	1/4" x 25' medium-duty air/water retractable hose reel	77	11.0	0 1595441502 2
1497NS	3/8" x 25' medium-duty air/water retractable hose reel	77	11.0	0 1595441503 9
1500	Mechanical non-totalizing in-line pint meter 1/2" NPT (F)	13	2.0	0 1595431500 1
1502	Mechanical pint totalizing in-line meter 1/2" NPT (F)	13	3.0	0 1595431502 5
1503	Mechanical pint totalizing pistol-type meter 1/2" NPT (F)	13	5.0	0 1595431503 2
1504	Digital totalizing meter w/ handle & flex nozzle	11	4.0	0 1595431531 5
1504AR	Digital in-line totalizing meter	11	2.0	0 1595431532 2
1505	Mechanical quart totalizing in-line meter 1/2" NPT (F)	13	3.0	0 1595431505 6
1507	Digital oval in-line gear meter w/ handle & flex nozzle 1/2" NPT	11	4.0	0 1595431527 8
1508	Mechanical quart totalizing pistol-type meter w/ rigid pipe 1/2" NPT (F)	12	5.0	0 1595431508 7
1508G	Gallon totalizing pistol-type quart meter w/ rigid pipe 1/2" NPT	12	5.0	0 1595431509 4
1508GG	Gallon totalizing pistol-type gallon meter w/ rigid pipe 1/2" NPT (F)	12	5.0	0 1595431510 0
1508L	Mechanical liter totalizing pistol-type meter w/ rigid pipe 1/2" NPT (F)	12	5.0	0 1595431509 4
1508Q	Mechanical quart totalizing pistol-type meter w/ rigid pipe 3/8" NPT (F)	12	5.0	0 1595431507 0
1509	Digital totalizing pistol-type meter w/ rigid pipe 1/2" NPT (F)	9	3.0	0 1595431510 0
1510	Digital totalizing electronic meter w/ hose & automatic nozzle	9	4.0	0 1595431535 3
1512	Digital liter and gallon fuel meter	63	1.5	0 1595431512 4
1514	Mechanical fuel meter 3/4" NPT	63	4.0	0 1595431514 8
1514-1	Mechanical fuel meter 1" NPT	63	4.0	0 1595431503 2
1514L	Mechanical fuel meter 3/4" NPT registers in liters	63	4.0	0 1595431517 9
1515	Mechanical quart totalizing pistol-type meter w/ 14" hose 1/2" NPT	12	5.0	0 1595431515 5
1515A	Quart totalizing pistol-type meter w/ 14" hose & automatic nozzle	12	5.0	0 1595431534 6
1515G	Mechanical quart dial w/ gallon totalizing meter	12	5.0	0 1595431496 7
1515GG	Mechanical gallon dial & totalizing meter	12	5.0	0 1595431496 7
1515L	Mechanical liter totalizing pistol-type meter w/ 14" hose 1/2" NPT	12	5.0	0 1595431516 2
1517	Digital totalizing preset meter w/ hose	7	4.0	0 1595431530 8
1519	Quart totalizing pistol-type meter w/ rigid pipe & automatic nozzle	8	5.0	0 1595431519 3
1519L	Liter totalizing pistol-type meter w/ rigid pipe & automatic nozzle	8	5.0	0 1595431544 5
1520	Gallon totalizing pistol-type quart preset meter w/ rigid pipe 1/2" NPT (F)	8	5.0	0 1595431520 9
1520GG	Gallon totalizing pistol-type gallon preset meter w/ rigid pipe 1/2" NPT (F)	8	5.0	0 1595431547 6
1520L	Mechanical liter totalizing pistol-type preset meter w/ rigid pipe 1/2" NPT (F)	8	5.0	0 1595431521 6
1522	Digital preset meter w/ rigid pipe & automatic nozzle 1/2" NPT	7	5.0	0 1595431539 1
1522RF	Digital preset meter for use w/ Wireless Oil Management System	10	5.0	0 1595431543 8
1523	Rubber-edged follower plate for 120 lb. drum 1-7/16" center diameter	42	4.0	0 1595441523 7
1524	Rubber-edged follower plate for 120 lb. drum 13/16" center diameter	42	4.0	0 1595441524 4
1525	Mechanical oval gear in-line meter w/ 1572 control handle & 1513A nozzle	13	4.0	0 1595431533 9
1525BC	Oval Gear Meter w/ Ctrl Handle	13	4.0	0 1595431591 9
1525AR	Mechanical oval gear in-line meter	13	2.0	0 1595431554 4
1527	Power pump valve w/ quart meter	16	6.0	0 1595441527 5
1529	Power pump valve and extension pipe	16	5.0	0 1595441529 9
1533	High-pressure booster control handle w/ pressure relief	41	2.0	0 1595441532 9
1534	High-pressure continuous flow control handle	41	2.0	0 1595441534 3
1536A	High-pressure grease booster control handle	41	2.0	0 1595441537 4
1537	1" inlet/outlet straight manual fuel nozzle	64	1.5	0 1595401537 6
1537-10	1" inlet/outlet straight manual fuel nozzle - 10 pk retail display	64	1.5	0 1595411537 3

Part Number Index

Part No.	Description	Page	Ship Wt.	UPC No.
1537C	1" inlet/outlet curved manual fuel nozzle	64	1.5	0 1595402537 5
1537C-10	1" inlet/outlet curved manual fuel nozzle - 10 pk retail display	64	1.5	0 1595412537 2
1537WS	1" inlet/outlet fuel nozzle & swivel w/ manual lock-on	64	1.5	0 1595401557 4
1538	3/4" inlet/outlet straight manual fuel nozzle	64	1.5	0 1595401538 3
1538-10	3/4" inlet/outlet straight manual fuel nozzle - 10 pk retail display	64	1.5	0 1595411538 0
1538C	3/4" inlet/outlet curved manual fuel nozzle	64	1.5	0 1595402538 2
1538C-10	3/4" inlet/outlet curved manual fuel nozzle - 10 pk retail display	64	1.5	0 1595412538 9
1537WS	1" inlet/outlet fuel nozzle & swivel w/ manual lock-on	64	1.5	0 1595401557 4
1538WS	3/4" inlet/outlet fuel nozzle & swivel w/ manual lock-on	64	1.5	0 1595401558 1
1539	1" inlet, 3/4" outlet straight manual fuel nozzle	64	1.5	0 1595401543 7
1539-10	1" inlet 3/4" outlet straight manual fuel nozzle - 10 pk retail display	64	1.5	0 1595411539 7
1539C	1" inlet 3/4" outlet curved manual fuel nozzle	64	1.5	0 1595401544 4
1539C-10	1" inlet 3/4" outlet curved manual fuel nozzle - 10 pk retail display	64	1.5	0 1595412539 6
1541	3/4" inlet/outlet automatic fuel nozzle	64	3.5	0 1595402541 2
1542	3/4" inlet 1" outlet automatic fuel nozzle	64	3.5	0 1595402542 9
1543	1" inlet/outlet automatic fuel nozzle	64	3.5	0 1595402543 6
1544	Straight swivel 1/4" (M) NPT x 1/4" (F) NPT	41	0.5	0 1595441544 2
1545	"Z" swivel for 1536A control handle	41	0.8	0 1595441545 9
1547	"Z" swivel for 1543 control handle	41	1.0	0 1595441547 3
1554	Mini air regulator for air-operated equipment	74	0.4	0 1595441554 1
1556BV	Ball valve for air-operated pumps 1/4" NPT x 1/4" NPT (F)	74	0.4	0 1595441556 5
1558A	Air line filter for air-operated pumps	74	2.0	0 1595441564 0
1559A	Mini air line filter w/ automatic drain	74	0.5	0 1595441566 4
1559A-ASSY	Mini air line filter, regulator, gauge, ball valve, & quick disconnects	74	2.0	0 1595441567 1
1559A2-ASSY	Mini air line filter, regulator, gauge, ball valve, 12" hose & mtg bracket	74	3.0	0 1595441590 9
1560	Air gauge for 1555 air regulator 1/4" NPT	74	0.4	0 1595441560 2
1561	Air gauge for 1554 air regulator 1/8" NPT	74	0.3	0 1595441561 9
1562	Safety blow gun (F)	86	0.5	0 1595431562 9
1563	Air chuck 1/4" NPT (F)	86	0.1	0 1595431563 3
1564	Engine clean gun for solvents or detergents	86	0.6	0 1595441564 3
1565	Zinc-plated quick connect air coupler 1/4" NPT	74	0.3	0 1595441565 7
1565L	Zinc-plated quick connect air coupler 1/4" NPT	74	0.3	0 1595441581 7
1567	Tire inflating chuck w/ gauge & 12" hose	86	1.0	0 1595431567 4
1570L	Quick connect air Nipple 1/4" NPT (M)	74	1.0	0 1595431499 8
1572	Control handle w/ 1/2" NPT swivel, trigger guard & lock	14	2.0	0 1595441572 5
1572R	Medium pressure control handle for oils, gear lube, ATF	14	2.0	0 1595441569 5
1573A	Heavy-duty filter, regulator, gauge & oiler combination unit 1/4" NPT (F)	74	1.5	0 1595441571 8
1574	Filter regulator, gauge & lubricator combination 3/8" NPT	74	4.0	0 1595441574 9
1575	Deluxe control handle w/ swivel, hose & nozzle	14	2.0	0 1595441575 6
1576	Deluxe control handle w/ swivel	14	2.0	0 1595441576 3
1578	Filter regulator, gauge & automatic drain	74	1.5	0 1595441578 7
1584	Oil control handle w/ 15° angled pipe	14	2.0	0 1595441584 8
1587	Low pressure control handle w/ swivel, flex hose & nozzle	14	2.0	0 1595441587 9
1588	1/2" radiator water bib	86	2.0	0 1595441588 6
1590	High flow meter totalizing in gallons or liters	10	8.0	0 1595431590 2
1608R	Heavy non-drip self closing oil bar spigot	23	3.0	0 1595441607 4
1608RNL	Oil bar tap non-locking NPT	23	2.6	0 1595441608 8
1610R	Single tap oil bar	23	57.0	0 1595441611 1
1615R	Single tap oil bar w/ meter	23	60.0	0 1595441616 6
1620R	Double tap oil bar	23	60.0	0 1595441621 0
1625R	Double tap oil bar w/ 2 meters	23	65.0	0 1595441626 5
1630R	Triple tap oil bar	23	63.0	0 1595441630 2
1635R	Triple tap oil bar w/ 3 meters	23	68.0	0 1595441635 7
1700R	3:1 ratio stub-style oil pump	18	17.0	0 1595441698 2
1702R	3:1 ratio oil pump for 55g gallon oil container	18	21.0	0 1595441697 5
1712	3:1 stub-style oil pump	17	11.0	0 1595441712 5
1712PPV	3:1 stub-style oil pump w/ power pump valve	16	12.0	0 1595441727 9
1713	3:1 oil pump for 16 gallon container	17	16.0	0 1595441713 2
1714	3:1 oil pump for 55 gallon container	17	11.0	0 1595441714 9
1716	3:1 oil pump for 275 gallon container	17	12.0	0 1595441721 7
1722	3:1 stub-style oil pump w/ pump valve	16	13.0	0 1595441752 1
1730A	5:1 stub-style oil pump	19	20.0	0 1595441729 3
1730R	5:1 stub-style oil pump	20	17.0	0 1595441696 8
1735R	1:1 stub-style oil pump	15	18.0	0 1595441732 3
1737	1:1 stub-style oil pump	15	12.0	0 1595441734 8
1745	5:1 oil pump for 55 gallon container	20	16.0	0 1595441745 3
1785	Vacuum pump w/ bung adapter, suction hose & air connection kit	6	7.0	0 1595441785 9
1795	Air-operated pump for water based fluids	100	11.0	0 1595441795 8
1802	High pressure hose 1/4" I.D. x 2' long 1/4" NPT (M)	75	0.8	0 1595451802 0
1804	High pressure hose 1/4" I.D. x 4' long 1/4" NPT (M)	75	2.0	0 1595451804 4
1806	High pressure hose 1/4" I.D. x 6' long 1/4" NPT (M)	75	3.0	0 1595451806 8
1810	High pressure hose 1/4" I.D. x 10' long 1/4" NPT (M)	75	4.0	0 1595451810 5
1812	High pressure hose 1/4" I.D. x 12' long 1/4" NPT (M)	75	5.0	0 1595451812 9
1816	High pressure hose 1/4" I.D. x 16' long 1/4" NPT (M)	75	7.0	0 1595451816 7
1820	High pressure hose 1/4" I.D. x 20' long 1/4" NPT (M)	75	8.0	0 1595451820 4
1825	High pressure hose 1/4" I.D. x 25' long 1/4" NPT (M)	75	10.0	0 1595451825 9
1850	High pressure hose 1/4" I.D. x 50' long 1/4" NPT (M)	75	19.0	0 1595451850 1
2134	Plastic pump hose 3/4" I.D. x 4' long w/ special thread (F)	75	1.0	0 1595452134 1

Part Number Index

Part No.	Description	Page	Ship Wt.	UPC No.
2136	Plastic pump hose 3/4" I.D. x 6' long w/ special thread (F)	75	2.0	0 1595452136 5
2154	Clear vinyl rotary pump hose 4' x 3/4" NPT (F)	75	1.0	0 1595452154 9
2156	Clear vinyl rotary pump hose 6' x 3/4" NPT (F)	75	2.0	0 1595452156 3
2158	Clear vinyl rotary pump hose 8' x 3/4" NPT (F)	75	2.0	0 1595452158 7
2178	Rubber rotary pump hose 8' long x 3/4" NPT (F)	75	4.0	0 1595452178 5
2205	Medium pressure hose 1/2" I.D. x 5' long 1/2" x 1/2" NPT (M)	75	2.0	0 1595452205 8
2210	Medium pressure hose 1/2" I.D. x 10' long 1/2" x 1/2" NPT (M)	75	4.0	0 1595452210 2
2215	Medium pressure hose 1/2" I.D. x 15' long 1/2" x 1/2" NPT (M)	75	6.0	0 1595452215 7
2220	Medium pressure hose 1/2" I.D. x 20' long 1/2" x 1/2" NPT (M)	75	8.0	0 1595452220 1
2225	Medium pressure hose 1/2" I.D. x 25' long 1/2" x 1/2" NPT (M)	75	7.0	0 1595452225 6
2250	Medium pressure hose 1/2" I.D. x 50' long 1/2" x 1/2" NPT (M)	75	12.0	0 1595452250 8
2300	Air hose 1/2" I.D. x 1 ft -1/2" NPT (M)	75	5.0	0 1595452300 0
2320	Air hose 1/2" I.D. x 20' long 1/2" NPT (M)	75	5.0	0 1595452320 8
2325	Air hose 1/2" I.D. x 25' long 1/2" NPT (M)	75	6.0	0 1595452325 3
2330	Air hose 1/2" I.D. x 30' long 1/2" NPT (M)	75	7.0	0 1595452330 7
2340	Air hose 1/2" I.D. x 40' long 1/2" NPT (M)	75	9.0	0 1595452340 6
2350	Air hose 1/2" I.D. x 50' long 1/2" NPT (M)	75	11.0	0 1595452350 5
3024	5 gallon portable oil dispensing system	22	30.0	0 1595453024 7
3574A	55:1 portable chassis grease pump w/ 6' hose for 35-50 lb. pail	36	24.0	0 1595443577 8
3574R	50:1 stationary grease system w/ 6' hose for 35-50 lb. pail	35	23.0	0 1595443790 1
3713	Stainless Micro-Matic Coupler with 3/4" hose barbed	68	2.0	0 1595442981 4
5001	2" vented locking fill cap	84	2.0	0 1595445001 6
5002	Vented fuel cap (cap only)	84	1.0	0 1595445002 3
5003	Vented Fuel cap with 2" base	84	2.0	0 1595445003 0
5072	RSV/RPV dispense coupler -threaded	68	2.0	0 1595442982 1
5265	Portable oil dispensing system w/ pump, meter & 17 gallon tank	22	71.0	0 1595445265 2
5702	Composite dispense coupler (DEF)	68	1.0	0 1595442983 8
5792	6" dual bung ibc center cap (Blue)	68	1.0	0 1595442984 5
6104	Equipment package 1712-2225-1504	Insd frt cvr	22.0	0 1595446104 3
6105	Equipment package 1712-1444R-1504	Insd frt cvr	85.0	0 1595446105 0
6112	Equipment package 1712-1444R-1515	Insd frt cvr	86.0	0 1595446112 8
6116	Equipment package 1712-1475R-1515	Insd frt cvr	67.0	0 1595446116 6
6120	Equipment package 1712-1444R-1520	Insd frt cvr	86.0	0 1595446120 3
6124	Equipment package 1712-1475R-1504	Insd frt cvr	66.0	0 1595446124 1
6167	Grease equipment package 1214-1440R	Insd frt cvr	103.0	0 1595446167 8
6168	Grease equipment package 1220R-1474R-120-S	Insd frt cvr	92.0	0 1595446168 2
6204	Equipment package 1702R-2225-1504-167	Insd frt cvr	35.0	0 1595446024 4
6215	Universal oil suction drain	32	151.0	0 1595446215 6
6401	Equipment package 1702R-1504-1475R-148	Insd frt cvr	152.0	0 1595446401 3
6403	Equipment package 1714-1475R-1515-148	Insd frt cvr	140.0	0 1595446403 7
6404	Equipment package 1702R-1475R-1515-148	Insd frt cvr	146.0	0 1595446404 4
6405	Equipment package 1745-1475R-1504-148	Insd frt cvr	136.5	0 1595446405 1
6520	Equipment package 1730A-1444-1520	Insd frt cvr	86.0	0 1595446520 1
6530	Equipment package 1730A-1444-1515	Insd frt cvr	86.0	0 1595446530 0
6601	Universal tote mounting plate	21	30.0	0 1595446601 7
6611	Tote mounting kit 1712-1475R-1525-6601	Insd frt cvr	90.0	0 1595446611 6
6612	Tote mounting kit 1712-1475R-1515-6601	Insd frt cvr	90.0	0 1595446612 3
6613	Tote mounting kit 1712-2225-1504-6601	Insd frt cvr	45.0	0 1595446613 0
6614	Tote mounting kit 1712-1475R-1504-6601	Insd frt cvr	75.0	0 1595446614 7
6709R	Equipment package 1700R-1444R-1509	Insd frt cvr	64.0	0 1595446709 0
6809R	Equipment package 1730R-1444R-1509	Insd frt cvr	64.0	0 1595446809 7
6815R	Equipment package 1730R-1444R-1515	Insd frt cvr	69.0	0 1595446815 8
7000	Cordless multi-purpose pump	101	1.0	0 1595446815 8
9115	Electric Diaphragm pump 115 volt 9 GPM	65	14.0	0 1595449115 6
9115TK	DEF-tote kit w/micro matic valve	65	32.0	0 1595449117 7
9115TKBS	DEF-basic tote kit w/ poly manual nozzle	65	29.0	0 1595449116 3
9115TKSN	DEF tote kit w/ S.S. nozzle and micro matic valve	65	32.0	0 1595449118 7
9115TKSNM	DEF- tote kit w/ S.S automatic nozzle & meter	65	3.0	0 1595449119 4
9810	Double diaphragm pump kit w/ 10' hose, control handle & adapter	5	22.0	0 1595449810 0
9825	Double diaphragm pump kit w/ 25' hose, control handle & adapter	5	25.0	0 1595449825 4
10010	1B Siphon Pump	98	0.5	0 1595460010 7
10020	4A Plastic Siphon Pump	98	2.0	0 1595460020 6
10039-1P	12' fuel hose 3/4" NPT (M) both ends	75	4.0	0 1595450039 1
10044	Polypropylene self priming piston lift pump-- 8 oz. per stroke	98	1.0	0 1595460040 4
10050	Polypropylene self priming piston lift pump-- 16oz per stroke	98	1.0	0 1595460050 3
10080	Economical zinc plated steel pump	94	2.0	0 1595460080 0
10110	316TSS--8oz per stroke--PTFE pump	99	3.0	0 1595460110 4
10120	Zinc-plated pail pump	94	3.0	0 1595460120 3
10130	Fast flow zinc plated pump	94	4.0	0 1595460130 2
10190	Die-cast zinc alloy pump	94	6.0	0 1595460190 6
10191	Chrome plated pump	94	5.0	0 1595460210 1
10193	Stainless-steel lever pump w/ PTFE seal	99	5.5	0 1595460193 7
10210	Economical cast iron pump	94	11.0	0 1595460210 1
10211	RP-90P polypropylene pump	96	5.0	0 1595460211 8
10231	PPS rotary pump w/ 3 piece PTFE vane	96	5.0	0 1595460231 6
10231TK	DEF-Manual pumping system for a tote or drum	65	29	0 1595460232 3
10240	HDPE PTFE Polyethylene Bleach, chlorine, chemicals compatible with HDPE	96	5.0	0 1595460240 8
10250	High flow gear driven rotary pump	95	12.0	0 1595460250 7

Part Number Index

Part No.	Description	Page	Ship Wt.	UPC No.
10255	RP - 90 PT polypropylene rotary pump w/ PTFE vane	96	5.0	0 1595460255 2
10256	RP - 90 PT PPS rotary pump w/ PTFE vane	96	6.0	0 1595460256 9
10265	DW - 100 drum wrench	81	2.0	0 1595460265 1
10266	DW - 200 drum bung wrench	81	2.0	0 1595460266 8
10267	DW - 300 iron drum plug wrench	81	4.0	0 1595460267 5
11219	Stainless-steel rotary pump w/ PTFE seals	99	14.0	0 1595461219 3
15441	1" inlet/outlet automatic fuel nozzle	64	4.0	0 1595402544 3
18573	Follower plate for 55 gallon container	42	12.0	0 1595408573 7
28623	Pressure relief valve 900 psi maximum	17	1.0	0 1595431506 3
28625	In-line pressure relief valve 900 psi maximum	18	1.0	0 1595431507 0
47721	2 oz. grease feeders polly base	47	1.0	0 1595447721 1
47722	6 oz. grease feeders polly base	47	2.0	0 1595447722 8
47724	2 oz. grease feeders alum base	47	1.0	0 1595447724 2
47725	6oz grease feeders alum base	47	2.0	0 1595447725 9
66590	Follower plate for 55 gallon container	42	11.0	0 1595446590 4
75000	3/4" NPT dual plane swivel	64	1.0	0 1595454659 0
75100	1" NPT dual plane swivel	64	1.0	0 1595405100 8
91203-19	12-volt car charger for 912-19 grease gun	46	1.0	0 1595410918 1
91204-19	Grease tube warming blanket	46	1.0	0 1595410919 8
103501	3/4" suction kit for 1035 double-diaphragm pump	5	21.0	0 1595441046 1
104001	1" suction kit for 1040 double-diaphragm pump	5	23.0	0 1595441047 8
104006G	Locking nut for D-S, 381 & 382 lever pumps	26	0.5	0 1595431508 7
107012	Follower plate for tapered or straight side pail 1-7/16" I.D.	42	2.0	0 1595407012 2
107014	Follower plate for tapered or straight side pail 1-3/16" I.D.	42	2.0	0 1595407014 6
107016	Follower plate for tapered or straight side pail 1" I.D.	42	2.0	0 1595407016 0
230000	Follower plate	42	1.0	0 1595407026 9
	Grease fittings & fitting accessories	56-57	--	N/A

The Maximum Response Team

We promise to provide the best service in our industries.
You will always receive our "Maximum Response".



Sam Goode
Chairman/CEO



Rick England
President



Greg ShROUT
Vice President
Western Region



Russell Spurgeon
Customer Service
Manager



Dustin Dougan
Sales Manager



Brad Buckley
Plant Manager



Jana Nicholson
Accounting Mgr.



Toni Box
Credit Mgr. /
Systems Admin.



Juaquina Bowers
Sales & Mktg.



Emily Wagoner
Customer Service



Carol Rubel
Customer Service

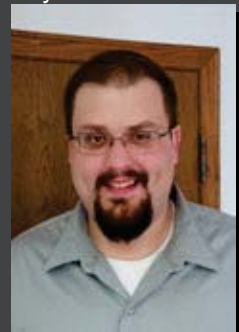

Tim Harshbarger
Customer Service





1ST RECHARGEABLE 19.2V BATTERY OPERATED PUMP

PART# 7019

19.2V Rechargeable Battery Operated Drum Pump

- Pumps at **7 GPM** (Pumps 106 gal. per charging)
- Uses all **PART# 912-19** battery and chargers to power it. (Lithium kit also available, pumps 30% more per charge)
- Includes one NiCad battery and one charger.
- Portable; no power outlets needed to pump fluid.
- Can pump DEF, and many other water based chemicals such as detergents, antifreeze, chemical insecticides, and soaps along with petroleum product such as diesel, kerosene, and light oils.
- Includes S.S. screened telescoping suction tube that extends from a min of 33.5" to 49".
- Comes with 2" NPT bung adapter and a 2" buttress adapter for plastic drums.
- Includes a 79" long corrugated P.E. hose with a Poly nozzle that has a 3/4" S.S. spout.
- Comes with a nozzle holster built in the pump body



Also Available
With Lithium Battery & Charger
For Longer Battery Life



NATIONAL - SPENCER, INC.

FLUID MANAGEMENT EQUIPMENT

SALES AND SERVICE

tel 800-231-1525

fax 800-637-9511

e-mail: sales@zeeline.com

CORPORATE & SALES OFFICE

National - Spencer, Inc

P.O. Box 57

Wichita, KS 67201

FACTORY & WAREHOUSE:

National - Spencer, Inc

1209 32nd Ave. West

Spencer, IA 51301

WAREHOUSE:

National - Spencer, Inc

2334 Stagecoach Road, Suite G

Stockton, CA 95215