

Quick Finder Index...

Fuel Injection Diagnostic and Cleaning Equipment and Tools	66-74
Fuel Line Disconnect Tools	75-76
Fuel Injection and Emission System Tools	77-78



FUEL SERVICE TOOLS

Fuel Service Tools

Only
OTC offers
you complete
fuel injection
service
coverage:

Diagnostic (Fuel Pressure Check)

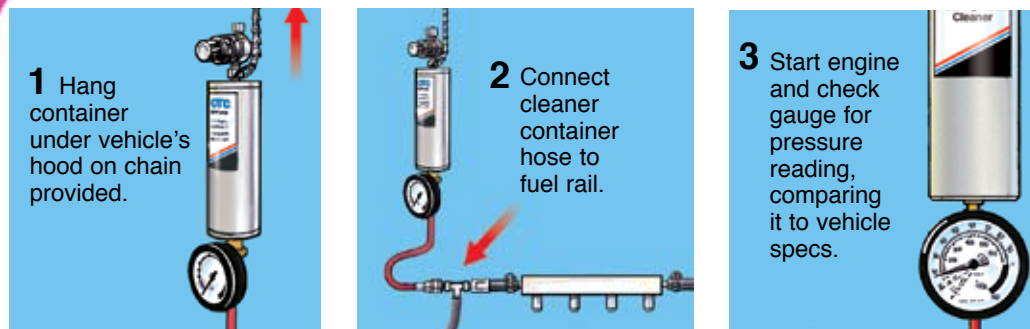

Cleaning Injectors

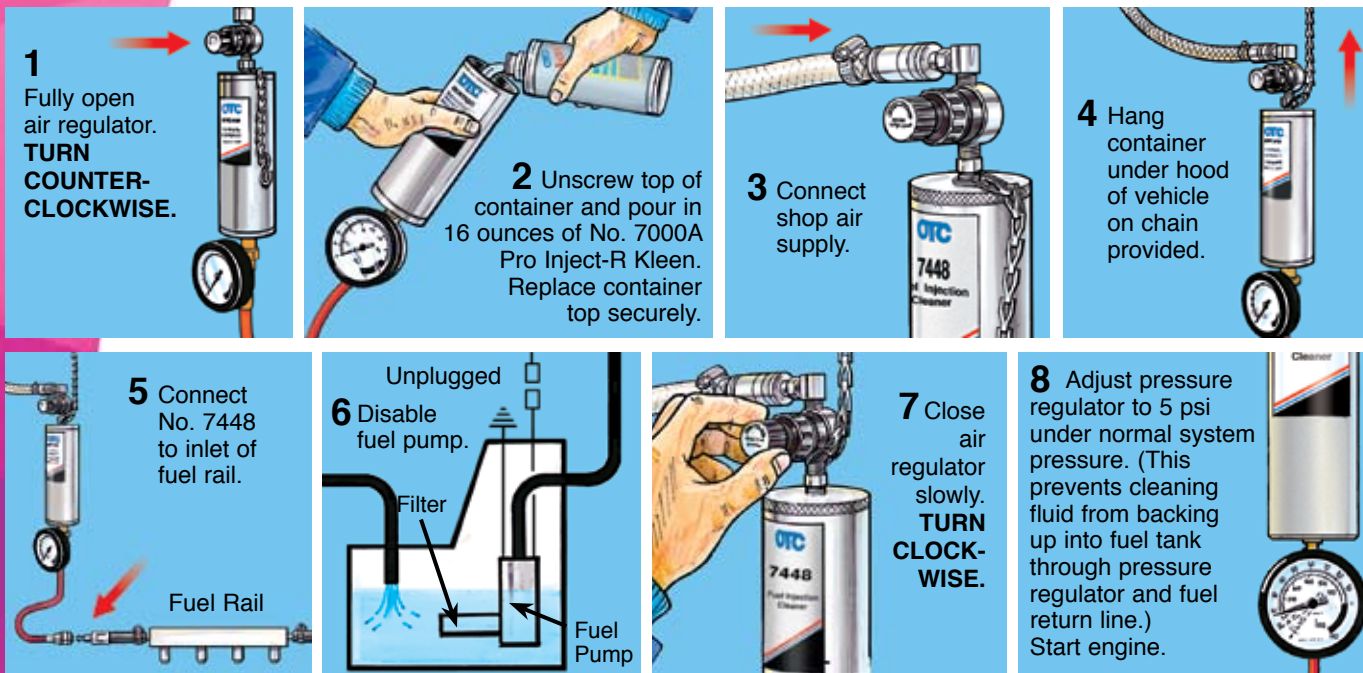

Intake System Decarbonizing

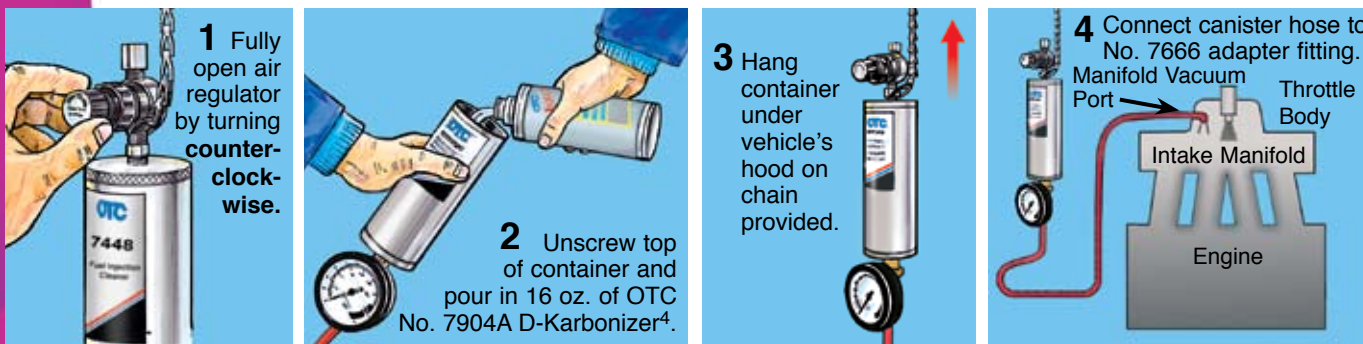

- 5** a) Locate a manifold vacuum port (NOT ported vacuum) near throttle body or carburetor to distribute decarbonizing solution evenly. Connect decarbonizer hose with adapter to vacuum port.
- b) Start engine. Manually increase throttle to 1,500 RPM. Slowly open shut-off valve until engine runs rough and RPM decreases. (Do not manually increase RPM at this point.)
- c) When 16 oz. of decarbonizer solution has been used, turn off engine. Remove adapter fitting from engine and reconnect vacuum hose. Do not start engine for at least 30 minutes, to allow cleaning solution to loosen carbon deposits.

Fuel Injector Cleaning Kit

Clogged fuel injectors cause sluggish engine performance, poor fuel economy, and a rough idle. You can easily correct such problems with this injector cleaning kit. It works on a wide range of engines, both domestic and imported. Using our Pro Inject-R Kleen fluid, you can effectively clean injectors, restore their spray patterns, and prevent recurring deposits. The kit also enables you to do low- and high-pressure fuel system tests. It will also work with your shop's pressurized air supply for more powerful cleaning without expensive propellants.

- Removes carbon from intake and combustion systems when used with fitting No. 7666 and No. 7904A D-Karbonizer⁴ fluid.
- Includes canister, gauge, hose, fittings, operating instructions.

No. 7649 – Fuel injector cleaning kit. Wt., 9 lbs., 10 oz.

No. 7659 – Fuel injector cleaning kit. Includes everything in kit No. 7649, plus twelve 16 oz. cans of Pro Inject-R Kleen fluid. Wt., 29 lbs.



7649

No. 7236 – Spring lock coupling adapter
No. 7272 – EFI quick-disconnect fitting (.307-32 internal; Ford)
No. 7273 – Pressure adapter TBI (5/16" and 3/8")
No. 7430 – Quick-disconnect 90° elbow fitting (7/16"-20 internal)
No. 7441 – Banjo fitting (M8 internal banjo)
No. 7442 – Banjo fitting (M10 internal banjo)
No. 7443 – Banjo fitting (M12 internal banjo)
No. 47955 – Fuel injector cleaner (canister)

Canister-type Fuel Injector Cleaner

When connected to your shop's pressurized air supply, this tool provides the most effective method of cleaning fouled fuel injectors. It's much quicker than aerosol methods, and it works on many domestic and imported engines, with either low- or high-pressure systems. The canister, built with brass and aluminum, is rugged and holds 18 fluid ounces. The gauge's large dial is easy to read. We recommend that our No. 7000A Pro Inject-R Kleen fluid be used with this cleaner.

- Works with all OTC fuel injection system adapters.
- Will remove carbon from intake and combustion systems, when used with our No. 7666 adapter and No. 7904A D-Karbonizer⁴ fluid.
- Includes gauge, 72" hose, under-hood hanger, and instructions.

No. 7448 – Canister-type fuel injector cleaner. Wt., 6 lbs., 14 oz.



7448

No. 313575 – Pressure gauge
No. 213299 – Air regulator
No. 213209 – O-ring
No. 206878 – Coupler socket
No. 306905 – Hose

Pro Inject-R Kleen Fluid

Clean fuel injectors mean cleaner running, more efficient engines – and lower emissions. This fluid restores injectors' original spray pattern, helps prevent recurring problems, and reduces intake and port deposits. We recommend it for all of our canister-type cleaning devices.

- No mixing; use right from the can.

No. 7000A – Pro Inject-R Kleen fluid. Case of 12 16-oz. cans. Wt., 13 lbs., 10 oz.

No. 7000A-1 – Pro Inject-R Kleen fluid single can.

D-Karbonizer⁴ Intake System Cleaning

When you need serious intake system cleaning, you need our D-Karbonizer⁴ fluid. It quickly strips away carbon, gum, and varnish. A clean intake and combustion system results in easier starting, less engine knocking, better fuel economy, and fewer emissions. We recommend it for all of our canister-type cleaning devices.

- No mixing; use right from the can.

No. 7904A – D-Karbonizer⁴ intake system cleaning treatment. Case of 12 16-oz. cans. Wt., 13 lbs., 10 oz.

No. 7904A-1 – D-Karbonizer⁴ single can.



7000A

Not a fuel additive
DO NOT POUR INTO
FUEL TANK.

Not a fuel additive
DO NOT POUR INTO
FUEL TANK.



7904A

FUEL SERVICE TOOLS

Fuel Service Tools



7797



7635A

Fuel Injection Diagnostic Set

With these sets, you can quickly and accurately diagnose fuel pressure problems on Chrysler, Ford, GM, or Jeep engines that have multi-port fuel injection systems. You can also bleed air from the system with the bleed valve. No. 7211 gauge assembly allows technicians to check fuel pressure and fuel volume.

Set Includes:

- No. 7665 – GM TBI fuel pressure adapter
- No. 7430 – Quick-disconnect 90° elbow fitting
- No. 7272 – Ford EFI quick-disconnect fitting
- No. 211398 – Pressure hose
- No. 206878 – Coupler
- No. 19088 – O-ring

No. 7797 – Fuel injection diagnostic set. Wt., 1 lb., 13 oz.

No. 7635A – Basic fuel injection diagnostic set. (Same as No. 7797, but does not include No. 7665 GM TBI adapter.) Wt., 1 lb., 8 oz.

Gauge and Hose Assembly

This gauge is designed to work with any of our fittings for testing fuel injection systems. It features a sturdy 3-1/2" dial that reads 0–100 psi. It also has a built-in (100–150 psi) retard to prevent excess pressure damage. The assembly's disconnect fitting has a check valve to lessen chance of fuel spray.

- Includes 6-ft. bleed hose and 30" pressure hose.
- Bleed valve eliminates air from injection system and can be used to reduce pressure when disconnecting hoses.
- Bleed valve also allows gauge assembly to be used to check fuel pump volume.

No. 7211 – Gauge and hose assembly. Wt., 1 lb., 3 oz.

No. 306905 – Optional pressure hose, 70" long. Wt., 7 oz.

No. 7211M – Gauge, 6' bleed hose, and 70" pressure hose.



7211

Fuel Pressure Tester Kit

Quickly and easily locate any malfunctioning fuel system component, including fuel filters, pressure regulators, fuel lines, and fuel pumps without removing it from the vehicle.

Features and benefits:

- Large, easy-to-read 0–100 psi scale, 0–700 kPa.
- Solid brass fittings.
- Pressure relief valve for safe, clean testing.

No. 5630 – Fuel pressure tester kit. Wt., 1 lb., 4 oz.



5630

Master Fuel Injection Kit

Test fuel injection systems on most GMs, including GM TBI, Ford, Chrysler, and Jeep vehicles. Also works on imports, including CIS and CISE fuel systems. With this kit you can diagnose fuel-related problems, such as a weak fuel pump or restricted fuel filter, and perform leak-down tests. Kit includes 0–100 psi fuel pressure gauge and 35 of the popular OTC fuel injection adapters, each equipped with a quick-connect Schrader valve. Replacement seal kit also included.

No. 6550 – Master fuel injection kit. Wt., 11 lb., 12 oz.

6550



Domestic Fuel Injection Kit

Test fuel injection systems on most GMs, including GM TBI, Ford, Chrysler, and Jeep vehicles. With this kit you can diagnose fuel-related problems, such as a weak fuel pump or restricted fuel filter, and perform leak-down tests. Kit includes 0–100 psi fuel pressure gauge and 17 of the popular OTC fuel injection adapters, each equipped with a quick-connect Schrader valve. Replacement seal kit also included.

No. 6551 – Domestic fuel injection kit. Wt., 4 lb., 2 oz.

6551



Import Fuel Injection Kit

Test fuel injection systems on imports, including CIS and CISE fuel systems. With this kit you can diagnose fuel-related problems, such as a weak fuel pump or restricted fuel filter, and perform leak-down tests. Kit includes 0–100 psi fuel pressure gauge and 23 of the popular OTC fuel injection adapters, each equipped with a quick-connect Schrader valve for. Replacement seal kit also included.

No. 6552 – Import fuel injection kit. Wt., 4 lb., 2 oz.

6552



Asian Fuel Injection Fitting Kit

The fittings in this kit enable you to connect OTC No. 7211 gauge (not included) to most Hyundai, Honda, Mitsubishi, and other Asian automotive engines, and diagnose most common fuel system problems involving low fuel pressure and low fuel volume at the injectors. Each fitting comes with a quick-connect Schrader valve for easy hookup to the gauge assembly.

- Fitting seals are compatible with most popular cleaning solvents.
- Includes operating instructions and handy blow-molded case.

No. 6570 – Asian fuel injection fitting kit. Wt., 3 lb.

6570



FUEL SERVICE TOOLS





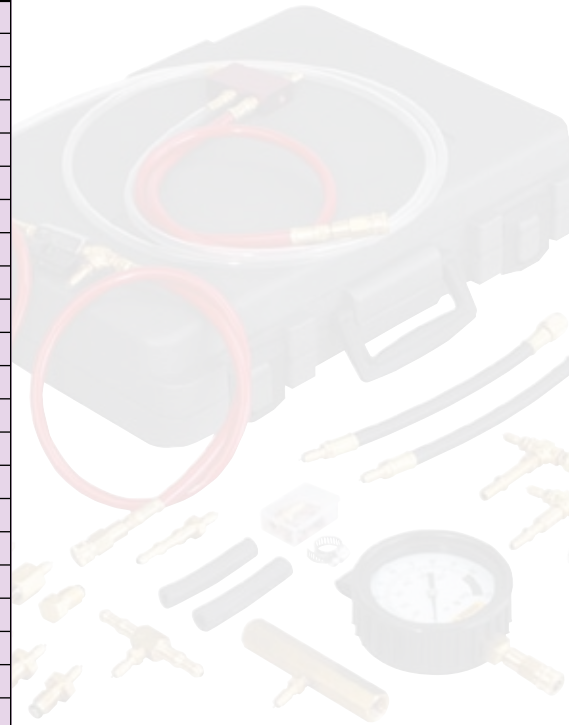





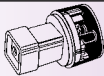

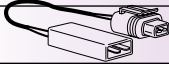
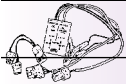





Fuel Injection Comparison Chart (Adapters, Fittings, and Accessories)

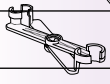



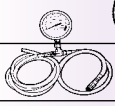
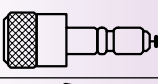
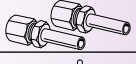
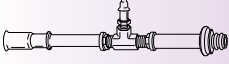

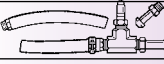



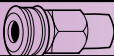











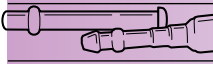

No.	Description	6550	6551	6552	6570
518356	CIS/TBI hose assembly with shutoff valve	•	•	•	
518472	16 mm x 1.5 internal o-ring adapter	•	•		
518473	14 mm x 1.5 external o-ring adapter	•	•		
518474	14 mm x 1.5 internal o-ring adapter	•	•		
518476	Ford hairpin adapter (5/16")	•	•		
518477	Seal Kit	•	•	•	
518478	Single-end hose adapter (1/4, 5/16, 3/8)	•	•	•	
518480	Double-end hose adapter (5/16, 3/8)	•	•	•	•
518481	16 mm x 1.5 external o-ring adapter	•	•		
518482	14 mm x 1.5 external o-ring plug	•	•		
518483	3-1/2" gauge, 0–100 psi (0–7 BAR)	•	•	•	
518484	M10 x 1.0 internal o-ring adapter	•		•	
518485	M8 x 1.0 internal o-ring adapter	•		•	
518486	M12 x 1.5 internal swivel adapter	•		•	
518487	GM TBI inline adapter (16 mm x 1.5)	•	•		
518488	M8 x 1.0 external o-ring adapter (long)	•		•	
518489	M10 x 1.0 external o-ring adapter	•		•	
518490	M6 x 1.0 external o-ring adapter	•		•	•
518491	M8 x 1.0 external banjo adapter	•		•	
518492	M10 x 1.0 external banjo adapter	•		•	
518493	M12 x 1.5 external banjo adapter	•		•	
518494	M12 x 1.25 external banjo adapter	•		•	•
518495	Ford flexible EFI adapter	•	•		
518496	M16 x 1.5 external & internal swivel adapter	•		•	
518497	1/4" BSPT external & internal swivel adapter	•		•	
518498	M14 x 1.5 external & internal swivel adapter	•		•	
518499	Ford spring lock adapter	•	•		
518501	M14 x 1.5 external banjo adapter	•		•	
518527	GM/Chrysler hairpin adapter (3/8")	•	•		
518530	Gauge hose assembly with relief valve	•	•	•	
518534	5/8" x 18 external flare adapter	•	•		
518535	5/8" x 18 internal flare adapter	•	•		
518536	M8 x 1.0 external o-ring adapter	•		•	
518537	M8 x 1.0 internal o-ring adapter (long)	•		•	
518542	7/16 x 20 GM/Chrysler flexible adapter	•	•		
528177	7/16 x 20 GM/Chrysler elbow adapter				
528178	7/16 x 20 GM/Chrysler straight adapter (short)				
528180	Low pressure gauge 0–15 psi (0–1 BAR)				
528182	16 mm x 1.5 elbow GM TBI fitting				
528183	3/8 hairpin adapter				
528541	5/8 x 18 flare straight adapter				
528766	M12 banjo adapter				•
528767	M8 x 1.0 double banjo bolt				•
528768	M12 x 1.25 double banjo bolt				•
528769	M8 banjo fitting				•
528770	.430 diameter adapter				•
528771	.560 diameter adapter				•
528772	5/8" diameter adapter				•
528773	O-ring & washer kit				
528774	O-ring & washer kit				•
528776	Ford EFI adapter				
528779	16 mm x 1.5 internal union adapter				



FUEL SERVICE TOOLS









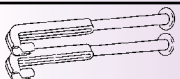

Fuel Injection Comparison Chart (Adapters, Fittings, and Accessories)





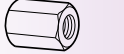

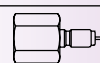

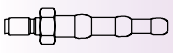
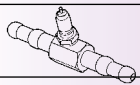
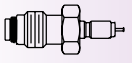
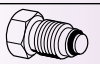
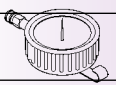
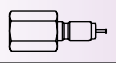
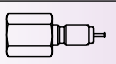
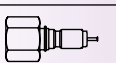
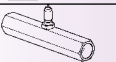

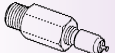
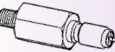
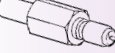
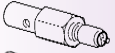

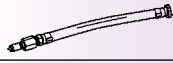
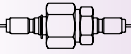

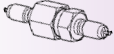
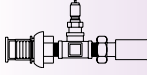
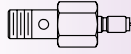
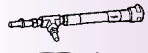

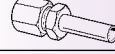

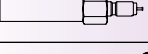
	Part No.	Description
	3054C	Noid Lite/IAC signal tester with fiber optic cable. Wt., 15 oz.
	3052S	IAC signal tester (GM). (Square 4-pin connector). Wt., 3 oz. See page 74.
	3053S	IAC signal tester (GM). (Flat 4-pin connector). Wt., 3 oz. See page 74.
	3305-53	TBI adapter. Wt., 11 oz.
	3320	2-in-1 idle air/idle speed control tester. Wt., 10 oz. See page 49.
	3397	Fuel injector tester (TBI adapter included). (Same as Kent-Moore J-39021-22.) Wt., 2 lbs., 10 oz. See page 48.
	3398	Fuel injection pulse tester. Wt., 10 oz. See page 74.
	4506	Fuel line clamp set. Wt., 6 oz.
	6023	Noid Lite (for GM Multec 2 injectors). Wt., 2 oz. See page 73.
	6260	Fiber Optic Noid Lite Extension Cable. Wt., 5 oz. See page 74.
	6266	Noid Lite (for GM Bosch 2 injectors). Wt., 2 oz.
	6509	Fuel line disconnect tool. Wt., 3 oz. See page 76.
	6511	Fuel line disconnect tool. Wt., 3 oz. See page 76.
	7000A	Injector cleaning fluid. case of 12 cans. Wt., 13 lb., 10 oz. See page 67.
	7187	Noid Lite (GM TBI). GM model 220, 300, 500 series TBI. Wt., 2 oz. See page 73.
	7188	Noid Lite (Bosch PFI). GM model 700 series TBI. Wt., 2 oz. See page 73.
	7211	Pressure gauge assembly (0-100 psi). Wt., 1 lb., 3 oz.
	7214A	Quick-disconnect straight fitting (1/16-20 internal). (Also conversion adapter for Champion and 3M.) Wt., 2 oz.
	7222A	Adapter set (5/8-18 internal, 45° flare inverted). Wt., 7 oz.
	7236	Spring lock coupling adapter same as Ford 310-D003 (D85L-9974-C). Wt., 7 oz.
	7244	Quick-disconnect tool (for duck bill clips). Same as Ford 307-123 (T82L-9500-AH). Wt., 2 oz.
	7272	EFI Quick coupler disconnect fitting (Ford .307-32 internal). Wt., 1 oz.
	7273	Pressure adapter (1/16" & 3/8" fuel line). Wt., 8 oz.
	7335	Fuel line disconnect tool (1/8") (yellow). Same as Ford 310-D004 (D87L-9280-A). Wt., 2 oz.
	7336	Fuel line disconnect tool (1/2") (green). Same as Ford 310-D005 (D87L-9280-B.) Wt., 2 oz.

	Part No.	Description
	7342	Quick coupler adapter. Wt., 2 oz.
	7370	Fuel line disconnect tool (1/16") (gray). Same as Ford 310-040 (T90T-9550-B). Wt., 1 oz.
	7371	Fuel line disconnect tool (1/8") (blue). Same as Ford 310-041 (T90T-9550-C). Wt., 1 oz.
	7430	Quick-disconnect 90° elbow fitting (7/16-20 internal). Also conversion adapter for Champion & 3M. Wt., 3 oz.
	7433	Fuel return line plug (3/8" external). Wt., 2 oz.
	7439	Pressure gauge (0-100 psi). Has a built-in retard (100-150 psi). Wt., 11 oz.
	7442	Banjo fitting (M10 internal banjo). Wt., 3 oz.
	7443	Banjo fitting (M12 internal banjo). Wt., 3 oz.
	7448	Fuel injector canister-type cleaner. Wt., 6 lbs., 13 oz. See page 67.
	7472	Conversion adapter (M12 x 1.5 internal ball nose snap-on). Wt., 3 oz.
	7597	Conversion Adapter Kit (7430 & 7472 snap-on). Wt., 7 oz.
	7601	Noid Lite (Ford TBI). Wt., 1 oz. See page 73.
	7602	Noid Lite (GM PFI). Wt., 1 oz. See page 73.
	7608	Noid Lite (Geo TBI). Wt., 1 oz. See page 73.
	7628	Special fitting set (5/16"). Wt., 3 oz.
	7629	Special fitting set (3/8"). Wt., 3 oz.
	7631	Fuel return line plug (5/16"). Wt., 2 oz.
	7655	Pinch-off pliers. Wt., 13 oz.
	7660	Fuel line disconnect tool. Same as Ford 310-052 (T93T-9550-AH). Wt., 2 oz.
	7666	Decarbonizing adapter. Wt., 5 oz.
	519154	Ford fuel line coupling tool. Same as 310-052 (T90T-9550-A). Wt., 1 oz. See page 77.
	519155	Chrysler fuel line disconnect Tool. Wt., 10 oz.
	7828	GM SCPI Noid-Lite. Wt., 2 oz. See page 73.
	518501	EFI pressure test adapter (M14 x 1.5 external double banjo). Wt., 3 oz.



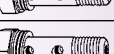

FUEL SERVICE TOOLS





Fuel Injection Comparison Chart (Adapters, Fittings, and Accessories)

Part No.	Description
 7896	Fuel line disconnect tool set, 5/16" red and 3/8" blue. (Same as Kent-Moore J-39504.) Wt., 7 oz.
 7902	Chrysler fuel injection fitting. Wt., 13 oz.
 7904A	D-Karbonizer ⁺ intake system cleaning fluid. Case of 12 cans. Wt., 13 lbs., 10 oz. See page 67.
 7915	Fuel injection quick coupler adapter. Wt., 2 oz.
 7923	Ford fuel injection adapter. Wt., 5 oz.
 7951	Ford idle speed control tester. Wt., 9 oz.
 518356	Fuel line adapter (CIS). Wt., 12 oz.
 518472	16 mm x 1.5 Internal o-ring adapter. Wt., 3 oz.
 518473	14 mm x 1.5 External o-ring adapter. Wt., 2 oz.
 518474	14 mm x 1.5 Internal o-ring adapter. Wt., 2 oz.
 518476	Ford hairpin adapter (5/16"). Wt., 5 oz.
 518477	Fuel injection seal kit. Wt., 2 oz.
 518478	Single-end hose adapter (1/4", 5/16", 3/8"). Wt., 12 oz..
 518480	Double-end hose adapter (5/16", 3/8"). Wt., 3 oz.
 518481	16 mm x 1.5 external o-ring. Wt., 2 oz.
 518482	Fuel return line plug (M14 x 1.5 external). Wt., 3 oz.
 518483	3-1/2" Gauge, 0-100 psi, 0-7 BAR. protective boot. Wt., 12 oz.
 518484	M10 x 1.0 internal o-ring adapter. Wt., 10 oz.
 518485	M8 x 1.0 Internal o-ring adapter. Wt., 10 oz.
 518486	M12 x 1.5 Internal swivel adapter. Wt., 1 oz.
 518487	GM TBI fuel pressure adapter. (16 mm x 1.5). Wt., 5 oz.

Part No.	Description
 518488	Quick-disconnect fitting (M8 x 1.0 x 3 3/8" long external o-ring). Wt., 3 oz.
 518489	Quick-disconnect fitting (M10 x 1.0 external o-ring). Wt., 2 oz.
 518490	Quick-disconnect fitting (M6 x 1.0 external o-ring). Wt., 3 oz.
 518491	Quick-disconnect banjo fitting (M8 x 1.0 external). Wt., 3 oz.
 518492	Quick-disconnect banjo fitting (M10 x 1.0 external). Wt., 3 oz.
 518493	Quick-disconnect banjo fitting (M12 x 1.5 external). Wt., 3 oz.
 518494	Quick-disconnect banjo fitting (M12 x 1.25 external). Wt., 3 oz.
 518495	Ford adapter, Schrader, .308 x 3/2 thread (Ford EFI). Wt., 2 oz.
 518496	M16 x 1.5 External & internal swivel adapter. Wt., 2 oz.
 518497	1/4" Pipe External & internal swivel adapter. Wt., 5 oz.
 518498	M14 x 1.5 External & internal swivel adapter. Wt., 2 oz.
 518499	Ford spring lock adapter. 2003 - newer with returnless fuel system. Wt., 7 oz.
 518501	M14 x 1.5 External banjo bolt. Wt., 2 oz.
 518527	3/8" Hairpin adapter. Wt., 5 oz.
 518530	Hose assembly with relief valve. Wt., 1 lb. 2 oz.
 518534	Adapter set (5/8-18 external, 45° inverted flare). Wt., 3.5 oz.
 518535	Adapter set (5/8-18 internal, 45° inverted flare). Wt., 3.5 oz.
 518536	Quick-disconnect fitting (M8 x 1.0 external o-ring). Wt., 2 oz.
 518537	M8 x 1.0 Internal o-ring adapter (long). Wt., 5 oz.
 518542	GMC/Chrysler adapter (7/16 x 20). Wt., 6 oz.
 528177	7/16 x 20 GM/Chrysler elbow adapter. Wt., 4 oz.
 528178	7/16 x 20 GM/Chrysler straight adapter (short). Wt. 4 oz.
 528180	Low-pressure gauge 0-15 psi (0-1 BAR). Wt. 12 oz.
 528182	16 mm x 1.5 elbow GM TBI fitting. Wt. 4 oz.
 528183	3/8 hairpin adapter. Wt. 4 oz.
 528766	M12 x 1.0 Double Banjo Bolt. Wt., 5 oz.
 528767	M8 x 1.0 Double Banjo Bolt. Wt., 2 oz.
 528768	M12 x 1.25 Double Banjo Bolt. Wt., 2 oz.

Fuel Injection Adapters, Fittings, and Accessories

Part No.	Description
 528541	5/8 x 18 flare straight adapter. Wt. 3 oz.
 528769	Banjo fitting (M8 banjo). Wt., 3 oz.
 528770	Quick-disconnect fitting (.430 Ø external) (Mitsubishi/Chrysler). Wt., 3 oz.
 528771	Quick-disconnect fitting (.580 Ø external) (Mitsubishi/Chrysler). Wt., 3 oz.
 528772	Quick-disconnect fitting (5/8" Ø external) (Mitsubishi). Wt., 5 oz.

Part No.	Description
 528773	O-ring and washer set for kit No. 6571. Wt. 1 oz.
 528774	O-ring and washer set for kit No. 6570. Wt. 1 oz.
 528776	Ford EFI Adapter. Wt. 4 oz.
 528779	16 mm x 1.5 Internal union adapter. Wt. 2 oz.

Noid Lite/IAC Test Kits

- Noid Lites are a proven test device to quickly determine if the electrical signal is present at the fuel injector.
- Simplest method for eliminating the EFI system or idle air control as possible faults on no-start vehicles.
- Disconnect the fuel injectors, plug in a Noid Lite, and crank the engine. A flashing noid light indicates normal pulsing voltage.

- Expanded set of eight specific Noid Lites covers: GM PFI, Ford TBI, Geo TBI, Bosch PFI, GM TBI, GM SCPI, Bosch 2, and Multec 2. Also includes two GM IAC testers (flat and square four-connector applications) with red and green LEDs.
- Kits come in molded plastic cases and include a fiber optic Noid Lite extension that allows for convenient remote viewing of noid lite flashing from the driver's seat.

No. 3050C – Noid Lite Test kit. Wt., 1 lb. 1 oz.

Set includes: (available separately)

- No. 7187** – GM TBI Noid Lite. Wt., 2 oz.
- No. 7188** – Bosch PFI Noid Lite. Wt., 2 oz.
- No. 7601** – Ford TBI Noid Lite. Wt., 2 oz.
- No. 6023** – GM Multec 2 Noid Lite. Wt., 2 oz.
- No. 7602** – GM PFI Noid Lite. Wt., 2 oz.
- No. 7608** – Geo TBI Noid Lite. Wt., 2 oz.
- No. 7828** – GM SCPI Noid Lite. Wt., 2 oz.
- No. 6266** – Bosch 2 Noid Lite. Wt., 2 oz.
- No. 6260** – Fiber optic Noid Lite extension. Wt., 5 oz.



Typical Noid Lite

3050C

No. 3054C – Noid Lite/IAC test kit. Wt., 1 lb. 3 oz.

Set includes: (available separately)

- No. 7187** – GM TBI Noid Lite. Wt., 2 oz.
- No. 7188** – Bosch PFI Noid Lite. Wt., 2 oz.
- No. 7601** – Ford TBI Noid Lite. Wt., 2 oz.
- No. 6023** – GM Multec 2 Noid Lite. Wt., 2 oz.
- No. 7602** – GM PFI Noid Lite. Wt., 2 oz.
- No. 7608** – Geo TBI Noid Lite. Wt., 2 oz.
- No. 7828** – GM SCPI Noid Lite. Wt., 2 oz.
- No. 6266** – Bosch 2 Noid Lite. Wt., 2 oz.
- No. 6260** – Fiber optic Noid Lite extension. Wt., 5 oz.
- No. 3052S** – '82 and newer GM TBI/PFI IAC tester with square 4-pin connector. Wt., 2 oz.
- No. 3053S** – '87 and newer Model 700 TBI/PFI with flat 4-pin connector. Wt., 2 oz.



3054C

FUEL SERVICE TOOLS

Fuel Service Tools



Similar to Kent-Moore J-34730-225

3397

Fuel Injection Tester

Fuel injectors can pass a resistance test but still fail under load. With this tool, you can check and balance fuel injectors. Also tests fuel injector coil windings under load, and detects intermittent fuel injector coil faults. Adjustable current output. Works on both throttle body and multiport fuel injectors. TBI adapter included.

No. 3397 – Fuel injector tester. Wt., 3 lbs., 5 oz.



3398

Fuel Injection Pulse Tester

Fuel injector testing requires precision equipment. This vehicle-powered tool fills that requirement. It enables you to check cylinder balance by firing individual injectors at 1/2-second increments in three different ranges: 1 pulse of 500 milliseconds, 50 pulses of 10 milliseconds, 100 pulses of 5 milliseconds.

- Power and output lights indicate test activation.
- Includes wiring harness adapter and instructions.

No. 3398 – Fuel injection pulse tester. Wt., 8 oz.

No. 306677 – Replacement lead. Wt., 2 oz.



3052S

3053S

General Motors IAC Signal Test Lights

For checking the electronic control module signal that provides direction to the idle air control motor on General Motors vehicles with throttle body or port fuel injection systems.

No. 3051 – Set consists of Nos. 3052S and 3053S. Wt., 4 oz.

No. 3052S – Signal test light for 1982 and newer GM TBI and PFI fuel injection systems with a square 4-pin connector. Wt., 2 oz.

No. 3053S – Signal test light for 1987 and newer GM Model 700 TBI and PFI fuel injection systems with a flat 4-pin connector. Wt., 2 oz.



6260

Fiber Optic Noid Lite Extension Cable

- Four-foot length permits easy viewing of Noid Lite signal. Used with OTC's Nos. 7187, 7188, 7601, 7602, 7608, 7828, 6023, and 6266, as well as other brands of Noid Lites.
- Noid Lite is inserted into cup end of extension cable, then plugged into vehicle's wiring harness. Fiber optic cable is routed out of engine compartment with end placed where it can be observed. Engine is cranked, and flashing at end of extension indicates normal injector pulsing voltage.
- Suction cup at end of extension cable permits secure placement on hood, fender, windshield, etc., without damage to surface.

No. 6260 – Fiber optic Noid Lite extension cable. Wt., 5 oz.

Full-Coverage Disconnect Tool Set

If you're working on Chrysler, Ford, or General Motors vehicles, this set will make your job easier. The tools are designed for heater hoses, transmission oil coolers, air conditioning and fuel lines. They're approved by vehicle manufacturers and will not damage the fittings being disconnected. Tool Nos. 518092, 518896, 518897, 518898, 518899, 518900, and 518901 are spring-loaded in the closed position to deflect any spray that occurs when lines are disconnected.

- Comes in blow-molded case.

No. 6508 – Disconnect tool set. Wt., 4 lbs., 8 oz.



Contents of set:

	Tool	Description
	440384	GM hydraulic clutch line disconnect tool.
	440486	GM transmission oil cooler line.
	511410	Fuel line disconnect tool.
	511413	Fuel line disconnect tool.
	518902	Heater hose disconnect tool.
	519158	Fuel line disconnect tool set.
	518582	Fuel line disconnect tool.
	518583	Fuel line disconnect tool.
	518584	Fuel line disconnect tool.
	518896	Fuel line disconnect tool. (Yellow, 3/8")
	518897	A/C spring lock coupling tool. (Black, 5/8")
	518898	A/C spring lock coupling tool. (Blue, 1/2")
	518899	Fuel line disconnect tool. (Green, 1/2")
	518900	A/C spring lock coupling tool. (Red, 3/8")

	Tool	Description
	518901	A/C spring lock coupling tool. (White, 3/4")
	519067	Fuel line disconnect tool.
	519068	Fuel line disconnect tool.
	519151	Quick disconnect tool.
	519152	Oil cooler line disconnect tool.
	519153	Clutch coupling tool.
	519154	Fuel line coupling tool.
	519155	Chrysler fuel line disconnect tool.
	519156	Ford heater hose disconnect tool.
	519157	GM heater line quick connect separator.
	519159	Oil cooler line disconnect tool.

FUEL SERVICE TOOLS

Fuel Service Tools



6517

Disconnect Tool Set

Designed for A/C lines, fuel lines, and transmission cooler lines.

- Contains 3/8", 1/2", 5/8", and 3/4" spring lock disconnect tools for A/C lines on 1981 thru 2006 Ford cars and trucks, 1994 thru 2006 Chrysler and Jeep vehicles.
- Contains the 3/8" and 1/2" fuel line disconnect tool for Ford vehicles.
- Contains the 5/16" and 3/8" fuel line disconnect tools for GM and Chrysler vehicles.
- Contains the transmission oil cooler line disconnect tool used on many GM and Ford vehicles.

No. 6517 – Disconnect tool set. Wt. 7 oz.



6603

Similar to Kent-Moore
No. J-46363.

GM Fuel Line Disconnect Tool

Applications: 2002–newer Tahoe and light-duty trucks with the 5.3L V8 engine.

- This is a required tool to remove the fuel line from the fuel filter.

No. 6603 – GM fuel line disconnect tool. Wt. 1 oz.



7337

Ford Fuel Line Disconnect Tool Set

These tools will easily disconnect the spring lock couplings of fuel lines on Ford's throttle body and port fuel injection systems. The tools are spring-loaded and durable, and they enclose the line to help deflect spray.

- Tools fit 3/8" and 1/2" lines.

No. 7337 – Ford fuel line disconnect tool set. Includes 7335 (3/8" yellow) and 7336 (1/2" green) disconnect tools. Wt., 4 oz.



7361

Similar to Ford
No. 310-5039
(T90T-9550-S)

Fuel Line Disconnect Tool Set

These two disconnect tools are designed to fit quick-connect fuel line fasteners. They'll work on Chrysler, Ford, or GM vehicles, and separate fuel lines without damaging the connectors.

- Tools fit 5/16" and 3/8" lines.

No. 7361 – Fuel line disconnect tool set. Includes 7370 (5/16" gray) and 7371 (3/8" blue) disconnect tools. Wt., 1 oz.



6509



6511

Fuel Line Disconnect Tools

• Special low-profile design works in close quarters on GM, Ford, and Chrysler vehicles where there is limited clearance between the fuel line fittings and fuel filters, fuel rails, or sending units. Both tools are designed to access the center port on the GM fuel tank sending unit.

No. 6509 – For 3/8" & 5/16" applications. Will also service 1999–current GM pickups, and 2000–current Suburban, Tahoe, and Yukon gasoline vehicles. Wt., 3 oz.

No. 6511 – For 3/8" and 1/2" applications. Will also service 2001–current 3/4- & 1-ton trucks with the Duramax diesel engines. Wt., 3 oz.

Fuel and Air Conditioning Line Release Tool

- This spring-lock coupling release tool easily separates fittings on fuel and air conditioning lines.
- Tool sizes are 3/4", 5/8", 1/2", and 3/8".

No. 4494 – Fuel and air conditioning line release tool. Wt., 5 oz.

4494



OTC Stinger

Ford Fuel Line Disconnect Tool Set

Here's the best tool for easy, frustration-free fuel line separation. As you put the tool on the fuel line coupling, its fingers depress the retaining collar to release the fuel line, preventing component damage.

- Works on 1990 to 1995 Ford Ranger and Explorer models fitted with 4.0L, 6-cylinder engines.

No. 519154 – Ford fuel line coupling tool. Wt., 2 oz.

519154



Rubber Line Clamp Set

- Set of two clamps. Used to quickly shut off flow from vacuum, brake, and fuel lines.
- Enables you to clamp and hold hose without damage.

No. 4506 – Rubber line clamp set. Wt., 6 oz.

4506

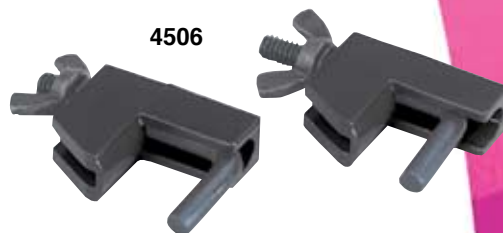

7-Piece Sensor Socket Set

Includes:

- No. 4673-1** – 29 mm pressure / vacuum switch socket.
- No. 4673-2** – 7/8" vacuum switch socket.
- No. 4673-3** – 27 mm oil pressure sending unit socket.
- No. 4673-4** – 7/8" vacuum switch socket.
- No. 4673-5** – 1-1/16" & 1" oil pressure sending unit socket.
- No. 4673-6** – 22 mm heated oxygen sensor wrench.
- No. 4673-7** – 7/8" short oxygen sensor socket.

No. 4673 – 7-Piece sensor socket set. Wt. 4 lbs. 10 oz.

4673



Oxygen Sensor Socket

- Designed to easily remove an oxygen sensor.
- Heat-treated cast steel.
- 7/8" hex, 1/2" square drive (double square for easy access).

No. 7189 – Oxygen sensor socket. Wt., 8 oz.

Similar to Ford
No. T79P-9472-A

7189



Oxygen Sensor Socket

- Works on all domestic and imported vehicles with oxygen sensors.
- Slot in socket's side allows wire clearance.
- Outside rib provides added strength, yet does not restrict access to sensors.
- 1/2" square drive, 1" male hex drive on top, 7/8" six-point opening, 3-7/8" long

No. 6931 – Oxygen sensor wrench. Wt., 1 lb.

6931



FUEL SERVICE TOOLS

Fuel Service Tools

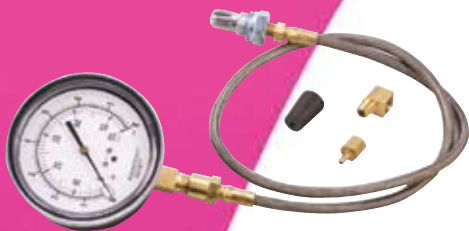

7215

Exhaust Back Pressure Gauge

Now you can quickly read back pressure to determine the amount of restriction in an exhaust system. This gauge accurately measures through the oxygen sensor hole. Its large dial clearly shows pressure from 0–8 psi. The system has a stainless steel braided tube to withstand high-heat conditions.

- Includes a universal adapter for vehicles with thermactor systems.
- Works on domestic and imported vehicles.

No. 7215 – Exhaust back pressure gauge with universal adapter. Wt., 1 lb., 3 oz.



7416

Fuel Emission Flow Meter

- Enables precise adjustment of engine idle mixtures.
- Works with OTC No. 7148 propane enrichment kit to monitor the propane going into the engine.
- Works on domestic or imported vehicles that have carburetors.

No. 7416 – Fuel emission flow meter. Wt., 6 oz.



Similar to Ford
No. 310-003
(T75L-9600-A)

7148

Propane Enrichment Kit

- Ensures a correct idle mixture and compliance with emission standards.
- Works on domestic or imported vehicles that have carburetors.
- Uses standard 14-oz. propane cartridge.

No. 7148 – Propane enrichment kit. Wt., 14 oz.



Similar to Miller
No. 6856

7998

Chrysler Fuel Pump Module Spanner Wrench

Removes and installs the fuel pump retaining ring that holds the fuel pump module onto the gas tank. Works on most 1994–2005 Chrysler vehicles, and 1995–2004 Jeep vehicles.

No. 7998 – Chrysler fuel pump module spanner wrench. Wt., 1 lb., 5 oz.



6599

Fuel Tank Lock Ring Wrench

Universal design allows tool to fit fuel tank lock rings on Ford, Chrysler, and GM vehicles with gas engines.

- Works on: 2004–newer Ford F-150 trucks; 2004–newer Chrysler / Dodge minivans, PT Cruiser, Dakota, and Durango; 2004–newer Chevy 1/2-ton and 3/4-ton trucks; and 2005–newer Jeep vehicles.
- Tool easily removes and installs lock ring on the fuel tank when servicing the fuel pump or fuel sending unit.
- Used with a 1/2" drive ratchet or breaker bar.

No. 6599 – Fuel tank lock ring wrench. Wt. 1 lb. 8 oz.



6598

Mercedes-Benz Fuel Tank Service Tool Kit

- Tool kit designed to remove fuel tank lids and plastic fuel tank cups to allow service on the fuel pump and/or the fuel sending unit.
- Works on Mercedes-Benz models W202 and W210.

No. 6598 – Mercedes-Benz Fuel Tank Service Tool Kit. Wt. 4 lb. 2 oz.

Quick Finder Index...

Puller “How-to” Information	206–207
Puller Safety Tips	207
Protective Blankets	207
Mechanical “Grip-O-Matic” Pullers	208
Hydraulic “Grip-O-Matic” Pullers	209
Mechanical Push-Pullers	209
Hydraulic Push-Pullers	210
Pulling Attachments	211
Puller Adapters	211–212
Slide Hammer Pullers	213–214
Bearing Pullers	214–215
Puller Sets	215–222



PULLERS

Selecting the "Right" Puller

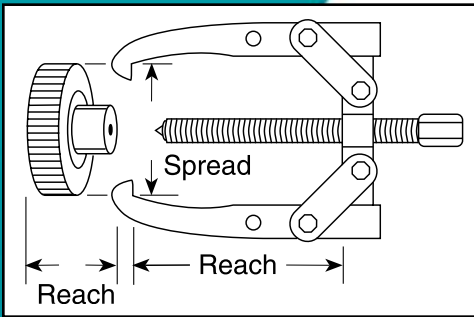

General Rule of Thumb: Manual pullers require that the puller screw be at least half as large (in diameter) as the shaft of the pulling job.

Hydraulic pullers need the maximum force exerted in tons to be 7–10 times the diameter of the shaft in inches.

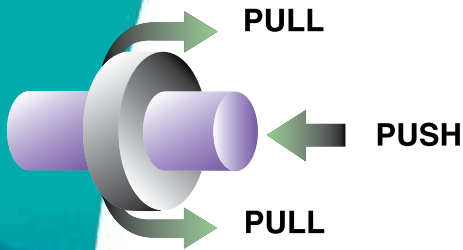

1 Pulling something off a shaft.

Removing a gear, bearing, wheel, pulley, etc., to replace it or get at another part.

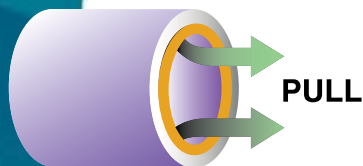

2 Pulling something out of a hole.

Internal bearing cups, retainers, or oil seals are usually press-fitted and are difficult to remove.

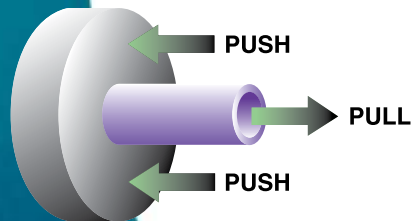

3 Pulling a shaft out of something.

A transmission shaft or pinion shaft is often hard to remove from a bore or housing. Use a Push-Puller with adapters if you can "get ahold of" the threaded end of the shaft. Sometimes it's possible to push a shaft through a housing, rather than pull it out. In applications of this type, the puller legs must be securely fastened to the housing and the screw may simply bear against the shaft.

You can solve the 3 basic pulling problems...

The first thing you have to do is identify exactly what your particular pulling problem is. Once you recognize the problem, you can go on to select the right tool to solve it.

How to select the "RIGHT" puller

1: Determine the type of puller or puller combination.

Which puller type is best for "getting a grip" on the part? Is a combination of puller types required?

2: Determine the "REACH" needed. The puller you select must have a "reach" equal to or larger than the corresponding sizes of the part.

3: Determine the "SPREAD" needed. The width of the part to be pulled will determine the "spread" required.

4: Estimate the force required. A puller with the correct "reach" and "spread" will **usually** have enough power. When in doubt, always use the next larger size. More power may be needed for rusted parts, or when the "area of resistance" is large.

The tools to use when pulling something off a shaft:

Jaw-type puller, either manual or hydraulic. (For extra force and convenience use a hydraulic puller.) Both are available in 2- or 3-jaw versions and are used to grip the outer circumference of an attachment.

Bearing pulling attachment. Provides "knife-like" edges to get behind the component, or when there isn't a good gripping area on the part to be pulled.

Push-Puller® with attachments. External-internal adapters can thread directly into tapped holes on a component. The splitter gets behind the component to prevent damage to the part.

Slide hammer puller with selected attachments for multiple light-duty pulling tasks.

A variety of OTC **adapters** can be used to protect a shaft, bridge a hole, thread into tapped holes, or assist installation.

The tools to use when pulling something out of a hole:

Internal pulling attachments have narrow jaws which extend through the center of the part to be pulled. They provide a straight pull and avoid damage to housings. Designed for use with Push-Pullers or slide hammer pullers.

Push-Puller in combination with internal pulling attachment. Both mechanical and hydraulically powered versions are available.

Here a **slide hammer puller** is combined with an internal pulling attachment. Ideal for removing parts from blind holes, especially when there is no housing to brace puller legs against.

When there is a shaft to bear against, a **forcing screw** of the correct size may be used in combination with an internal pulling attachment.

The tools to use when pulling a shaft out of something:

Push-Puller® with threaded adapter. Use a mechanical or hydraulic puller, depending on the size of the shaft to be pulled.

When the housing lacks sufficient surface for the puller legs to bear against, a **pulling attachment** may be used to provide support.

Slide hammer puller with threaded adapter – either external-internal or internal can be used.

Internal adapters are fastened to the external threaded end of the shaft to pull while pushing against the housing.

External-internal adapters are threaded into the shaft to pull it while pushing against the housing.

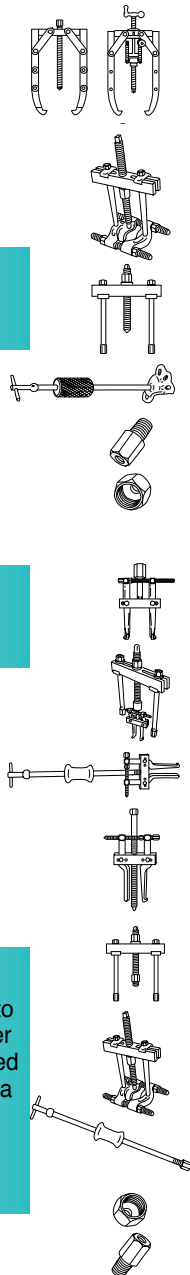

Your pulling system exerts tons of force. You must respect this force, and observe safety precautions at all times.

Caution

It is impossible to predict the exact force required for every pulling job: setup requirements and the size, shape, and condition of the parts being pulled vary a great deal. In addition, the OTC Pulling System is so versatile, it is possible that components in a pulling setup may have different tonnage ratings. The lowest “capacity” component, then, determines the capacity of the setup. For example: When an accessory with a 1-ton capacity is used with a 10-ton capacity puller, the setup can be used only at a force of one ton.

These tools should be used only by trained personnel familiar with them. Always wear eye protection during a job, since work parts, or the pulling tool itself, may break and parts may fly. It is recommended to cover the work with an OTC Protective Blanket or use a shield while force is being applied.

If you are at all unsure which tool or attachment to select, contact Technical Services.

A Few Easy Tips to Remember

Wear safety glasses at all times!

You have only one set of eyes, so protect them from possible flying parts.

Keep your pulling tools in shape!

Clean and lubricate the puller’s forcing screw frequently, from threads to tip, to ensure long service life and correct operation.

Cover work with a protective blanket!

With high forces being exerted on the part being pulled, breakage may sometimes result. By covering the work with a protective blanket, the user reduces the danger of flying parts.

Apply force gradually!

The component should give a little at a time. Do not try to speed up removal by using an impact wrench on the puller screw.

Use the right size puller!

If you have applied maximum force and the part has not moved, go to a larger capacity puller. Resist sledging.

Protective Blankets

Think of them as “security blankets.” They wrap around pulling, pressing, and other high-force jobs to protect you and your employees from work-related injuries as much as possible. They’re made of high tensile, tear resistant ballistic nylon – similar to military flak jackets – that, when tested, withstood the shattering of a neck-down grade 8 bolt without any visible damage.

NOTE: Always reduce the force from the workpiece prior to removing the blanket. Protective blankets may afford protection from injuries to users and others should part breakage occur. Because of the variety of situations that require guarding, it is the user’s responsibility to determine the best method of protection.

No. 1230PB – Protective blanket. 12" x 30". Wt., 2 lbs., 3 oz.

No. 2036PB – Protective blanket. 20" x 36". Wt., 3 lbs.

No. 2860PB – Protective blanket. 28" x 60". Wt., 7 lbs.



Grip-O-Matic pullers

Align puller legs and jaws.

Be sure the setup is rigid and the puller is square with the work.

Mount puller so grip is tight!

Tighten the adjusting strap bolts when using a jaw-type puller.

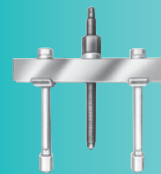

Push-Pullers

Do not couple puller legs!

The tonnage capacity of a Push-Puller is reduced when longer-than-standard legs are used, or when legs are in compression. The chance of breaking, bending, or misaligning legs increases. Always use the shortest legs possible to do the job.



Bearing pulling attachments

These attachments may not withstand the full tonnage of the pullers with which they are used. The shape and condition of the part being pulled affects the tonnage at which the puller blocks and/or studs may bend or break. Always select the largest attachment that will fit the part to be pulled.



1230PB

PULLERS

Mechanical Grip-O-Matic® Pullers

Mechanical Grip-O-Matic® Pullers

OTC has developed the most complete line of gear and bearing pullers, enabling you to remove and install parts for fast, effective repairs. The pullers are forged from quality steel, heat treated, and subjected to rigorous tests which exceed their rated capacity.

No. 1020–1050

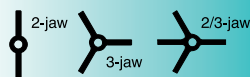
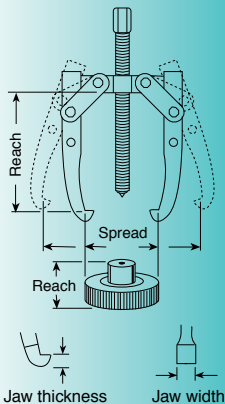

WARNING
Wear approved eye protection when using pullers.
See page 207 for protective blankets for your pulling jobs.

Tool No.	MAX.		Screw Size	JAW		Capacity, Style, and Weight	
	Reach	Spread		Thickness	Width		
	1020	2-1/8"	3-1/4"	5/16"-24 x 3-7/8"	9/64"	1/4"	1-Ton, 2-Jaw; 5 oz.
	1022	3-1/4"	4"	3/8"-24 x 4-7/8"	Upper 3/16" Lower 1/8"	Upper 1/4" Lower 1/2"	2-ton, 2-Jaw; 14 oz. (Reversible Jaws)
	1024	3-1/4"	6"	9/16"-20 x 6-15/16"	Upper 5/16" Lower 1/4"	Upper 3/8" Lower 3/4"	5-Ton, 2-Jaw; 1 lb., 12 oz. (Reversible Jaws)
	1025	5-1/2"	6"	9/16"-20 x 6-15/16"	Upper 5/16" Lower 1/4"	Upper 3/8" Lower 3/4"	5-Ton, Long 2-Jaw; 2 lbs. (Reversible Jaws)
	1035	5"	9"	11/16"-18 x 9"	Upper 5/16" Lower 11/32"	Upper 1" Lower 1"	7-Ton, 2-Jaw; 4 lbs., 8 oz. (Reversible Jaws)
	1036	8-3/4"	9-1/2"	11/16"-18 x 9"	11/32"	1"	7-Ton, Long 2-Jaw; 5 lbs., 6 oz.
	1039	11"	12"	13/16"-16 x 12"	9/16"	1"	13-Ton, 2-Jaw; 10 lbs., 13 oz.
	1040	15-1/4"	15-1/2"	13/16"-16 x 12"	9/16"	1"	13-Ton, Long 2-Jaw; 13 lbs.
	1043	14-1/2"	14"	1"-14 x 13-1/2"	13/16"	1-9/32"	17-1/2-Ton, 2-Jaw; 23 lbs.
	1044	18-3/4"	16"	1"-14 x 13-1/2"	13/16"	1-9/32"	17-1/2-Ton, Long 2-Jaw; 26 lbs.
	1047	15-1/2"	18"	1-1/4"-12 x 15-15/16"	1-1/16"	1-1/2"	25-Ton, 2-Jaw; 37 lbs., 8 oz.
	1048	22-1/4"	20"	1-1/4"-12 x 15-15/16"	1-1/16"	1-1/2"	25-Ton, Long 2-Jaw; 42 lbs., 12 oz.
	1049	15-1/2"	18"	1-1/4"-12 x 15-15/16"	1-1/16"	1-1/2"	25-Ton, 3-Jaw; 54 lbs.
	1048	22-1/4"	20"	1-1/4"-12 x 15-15/16"	1-1/16"	1-1/2"	25-Ton, Long 3-Jaw; 60 lbs.

Hydraulic Grip-O-Matic® Puller

No. 1065-1080 Available in 17-1/2 to 50-ton capacities. Reliable single-acting Power Twin ram is matched with a versatile 2-jaw or 3-jaw puller. Lightweight ram can be used in other applications. You also get an adjusting screw, speed crank, and coupler where applicable. Hydraulic pump is not included; see index for pump listings.

Tool No.	MAX.		Ram Capacity & Number	JAW		Screw Size & Crank No.	Style and Weight
	Reach	Spread		Thickness	Width		
1065	11-1/2"	16"	17-1/2 Ton, No. 4120	13/16"	1-9/32"	1"-8 x 20" No. 24814	17-1/2 Ton, 2-Jaw; 40 lbs.
1064	11-1/2"	16"	N/A	13/16"	1-9/32"	N/A	17-1/2 Ton, 2-Jaw Puller Only; 24 lbs.
1067	11-1/2"	20"	17-1/2 Ton, No. 4120	13/16"	1-9/32"	1"-8 x 20" No. 24814	17-1/2 Ton, 3-Jaw; 53 lbs.
1066	11-1/2"	20"	N/A	13/16"	1-9/32"	N/A	17-1/2 Ton, 3-Jaw Puller Only; 37 lbs.
1073	19-7/16"	26"	30-Ton, No. 4121	1-1/8"	1-5/8"	1-1/4"-7 x 24" No. 27198	30-Ton, 2-Jaw; 91 lbs.
1072	19-7/16"	26"	N/A	1-1/8"	1-5/8"	N/A	30-Ton, 2-Jaw Puller Only; 59 lbs.
1075	19-7/16"	34"	30-Ton, No. 4121	1-1/8"	1-5/8"	1-1/4"-7 x 24" No. 27198	30-Ton, 3-Jaw; 122 lbs.
1074	19-7/16"	34"	N/A	1-1/8"	1-5/8"	N/A	30-Ton, 3-Jaw
1080	19-7/16"	44"	N/A	1-1/8"	1-5/8"	N/A	50-Ton, 3-Jaw Puller Only; 187 lbs.



Puller components

	No.	Description	Capacity in Tons
	24814	Speed Crank	17-1/2
	27198	Speed Crank	30
	29595	Speed Crank	50
	32118	Adjusting Screw	17-1/2
	34758	Adjusting Screw	30
	32698	Adjusting Screw	50
	39448	Lube for pullers	

Push-Pullers®

No. 927 – 10-Ton Capacity Can be used with No. 1123 bearing pulling attachment or No. 679 pulley pulling attachment. May also be used with Nos. 1150, 1151, 1152, or 1153 internal pulling attachments.

No. 938 – 17-1/2 Ton Capacity Can be used with Nos. 1124 and 1130 bearing pulling attachments or Nos. 679 and 680 pulley pulling attachments. May also be used with Nos. 1150, 1151, 1153, 1165, or 1166 internal pulling attachments.

No. 939 – 30-Ton Capacity Can be used with Nos. 1126 and 1127 bearing pulling attachments or No. 680 pulley pulling attachment (two 8012 adapters are required to connect 680 to puller). Can be used with No. 1165 internal pulling attachment.

Tool No.	MAX.		Screw Size	Notes / Weight
	Reach	Spread		
927	8-1/4"	2-1/8" – 7-1/4"	3/4"-16 x 12"	1/2" of forcing screw tip end is threaded 5/8"-18. No. 1100 legs and No. 24827 leg ends included. Wt., 7 lbs.

Extra Legs (pair) for No. 927 Push-Puller (Reach equals leg length plus 1-1/2" with leg end caps.)

Tool No.	Leg Length & Wt.	Tool No.	Leg Length & Wt.
1103	4-3/4" 1 lb.	1102	11-3/4" 2 lbs., 4 oz.
1100	6-3/4" 1 lb., 8 oz.	1101	15-3/4" 3 lbs., 4 oz.

938	11-1/2"	3-1/8"-11-3/4"	1"-14 x 13-1/4"	Leg ends threaded 5/8"-18. No. 1106 legs and No. 24827 leg ends included. Wt., 20 lbs., 12 oz.
-----	---------	----------------	-----------------	--

Extra Legs (pair) for No. 938 Push-Puller (Reach equals leg length plus 2" with leg end caps.)

Tool No.	Leg Length & Wt.	Tool No.	Leg Length & Wt.
1107	4-1/2" 2 lbs., 8 oz.	1105	22-1/2" 9 lbs.
1106	9-1/2" 4 lbs., 8 oz.	1108	30" 11-1/2" lbs.
1104	16-1/2" 6 lbs., 8 oz.		

939	10-1/2"	7"-16-1/4"	1-1/2"-12 x 17-1/4"	Leg ends threaded 1"-14. No. 1109 legs and No. 28390 leg ends included. Wt., 44 lbs.
-----	---------	------------	---------------------	--

Extra Legs (pair) for No. 939 Push-Puller (Reach equals leg length plus 2-5/8" with leg end caps.)

Tool No.	Leg Length & Wt.	Tool No.	Leg Length & Wt.
1109	8" 8 lbs.	1111	28" 22 lbs.
1110	18" 15 lbs.		



PULLERS

Hydraulic Push-Pullers

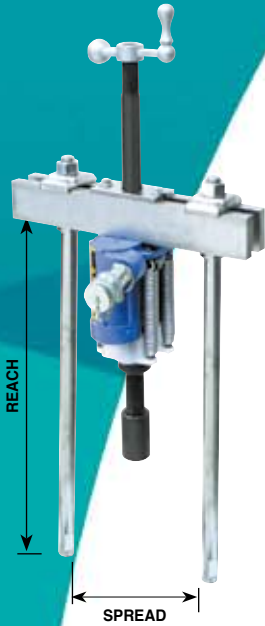

No. 1062 & 1063
Usable reach equals leg length minus 4-7/8" when using leg ends.

No. 1070 & 1071
Usable reach equals leg length minus 5-7/8" when using leg ends.

No. 1076
Usable reach equals leg length minus 10-5/8".

Hydraulic Push-Puller

No. 1062, 1063 – 17-1/2" Ton Capacity Can be used with Nos. 1124 and 1130 bearing pulling attachments or No. 680 pulley pulling attachment. May also be used with No. 1154 internal pulling attachment. Ends of legs are threaded 5/8"-18. Usable reach: 11-5/8".

Tool No.	MAX.		Screw Size	Notes / Weight
	Reach	Spread		
1063	18-1/2"	5-3/4"-11-3/4"	1"-8 x 20"	Puller with No. 1104 legs, No. 24827 leg ends, No. 4120 hyd. ram, No. 32118 adjusting screw, and No. 24814 adjusting crank. 38 lbs.
1062	18-1/2"	5-3/4"-11-3/4"	1"-8 x 20"	Puller only. 22 lbs.

Extra Legs (pair) for No. 1062, 1063 (Reach equals leg length plus 2" with leg end caps.)

Tool No.	Leg Length & Wt.	Tool No.	Leg Length & Wt.
1107	4-1/2" 2 lbs., 8 oz.	1105	22-1/2" 9 lbs.
1106	9-1/2" 4 lbs., 8 oz.	1108	30" 11-1/2 lbs.
1104	16-1/2" 6 lbs., 8 oz.	Note: 3/4"-14 thread on leg upper end. ← LEG LENGTH →	

No. 1070, 1071 – 30-Ton Capacity Can be used with Nos. 1126 and 1127 bearing pulling attachments or No. 680 pulley pulling attachment (two No. 8012 adapters are required to connect No. 680 to puller). Also may be used with No. 1166 internal pulling attachment. Ends of legs are threaded 1"-14. Usable reach: 12-1/8".

Tool No.	MAX.		Screw Size	Notes / Weight
	Reach	Spread		
1071	20-1/2"	7"-16-1/4"	1-1/4"-7 x 24"	Puller with No. 1110 legs, No. 28390 leg ends, No. 4121 hyd. ram, No. 34758 adjusting screw, and No. 27198 adjusting crank. 90 lbs.
1070	20-1/2"	7"-16-1/4"	1-1/4"-7 x 24"	Puller only. 56 lbs.

Extra Legs (pair) for No. 1070, 1071 (Reach equals leg length plus 2 5/8" with leg end caps.)

Tool No.	Leg Length & Wt.	Tool No.	Leg Length & Wt.
1109	8" 8 lbs.	1111	28" 22 lbs.
1110	18" 15 lbs.	Note: 1"-14 thread on both ends of legs	

No. 1076 – 50-Ton Capacity Can be used with Nos. 1128 and 1129 bearing pulling attachments. Ends of legs are threaded 1-1/4"-12. Usable reach: 13-3/8". See pages 211-212 to order threaded adapters for use with these pullers.

Tool No.	MAX.		Screw Size	Notes / Weight
	Reach	Spread		
1076	24"	8-1/2"-20-1/2"	1-5/8"-5-1/2 x 30-3/8"	Puller only. 106 lbs.

Extra Legs (pair) for No. 1076 (Reach equals leg length.) Note: 1-1/4"-12 thd. on both leg ends.

Tool No.	Leg Length & Wt.	Tool No.	Leg Length & Wt.
1112	24" 34 lbs.	1113	34" 47 lbs.

Bearing Splitters

No. 1121-1130 These versatile accessories feature "knife-like" edges which are easily placed behind the part to secure a gripping surface, even when clearances are extremely limited. When used with an OTC Grip-O-Matic® puller, puller jaws grip attachment's outer edge; when used with a Push-Puller, puller legs are threaded into the attachment's two tapped holes.

Tool No.	MAX. Spread	MIN. Spread	A	B	Weight	Application
1121	15/16"	1/4"	15/16"-18	1-11/16"	12 oz.	Use with puller Nos. 1020, 1022, & 1023.
1122	2"	1/8"	3/8"-16	2-7/16"	1 lb., 4 oz.	Use with puller Nos. 1024, 1025, 1026, 1027, 7392, & 7393.
1123	4-5/8"	1/2"	5/8"-18	4-3/8"	5 lbs.	Use with puller Nos. 1035, 1036, 1037, 1038, & 927.
1124	5-3/4"	1/2"	5/8"-18	6"	12 lbs.	Use with puller Nos. 1035, 1040, 1041, 1042, 1065, 1063, & 938.
1130	9"	1/2"	5/8"-18	6"	12 lbs., 9 oz.	Use with puller Nos. 1035, 1040, 1041, 1042, 1065, 1063, & 938.
1126	8"	5/8"	1"-14	7-1/8"	19 lbs., 12 oz.	Use with puller Nos. 1047, 1043, & 939.
1127	13-3/8"	3/4"	1"-14	10-1/4"	41 lbs., 12 oz.	Use with puller Nos. 1047, 1073, & 939.
1128	12-7/8"	5"	1-3/4"-12	13"	100 lbs.	Use with puller Nos. 1073, 1079.

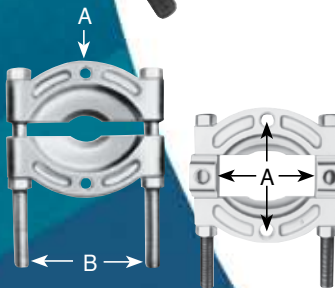

A = Thread of tapped hole in adapter.
B = Distance between adjusting screws.

Pulley Pulling Attachments

Attachment clamps down into V-groove to distribute load. Use with Grip-O-Matic® pullers or Push-Pullers.

Tool No.	MAX. Spread	MIN. Spread	A	B	Weight	Application
679	5-7/8"	1-3/4"	5/8"-18	6"	4 lbs., 4 oz.	Use with puller Nos. 1035, 1036, 1037, 1038, and 927.
680	10"	1-5/8"	5/8"-18	10-1/16"	22 lbs., 4 oz.	Use with puller Nos. 1039, 1040, 1041, 1063, 1065, and 938.

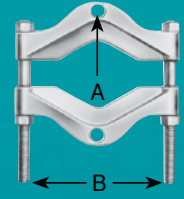
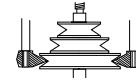

A = Thread of tapped hole in adapter.
B = Distance between adjusting screws.

Internal Pulling Attachments

Approved by leading bearing manufacturers, OTC's internal pulling attachments remove bearing cups, oil seals, bushings, and other parts from blind holes quickly and easily. Each attachment is designed for use with a corresponding Push-Puller or slide hammer assembly.

Tool No.	JAW		A	B	Weight	Application
	Spread	Reach				
1153	1-1/2"-5"	2-1/8"	1"-14	5/8"-18	4 lbs., 4 oz.	Use with Nos. 927 and 938 Push-Pullers, 1155 and 1156 slide hammer pullers, or 24832 and 24833 puller screw.
1150	1-1/2"-6"	4"	1"-14	5/8"-18	4 lbs., 4 oz.	
1152	1-1/2"-6"	4"	-	5/8"-18	3 lbs., 8 oz.	
1151	1-1/2"-7"	5-1/4"	1"-14	5/8"-18	4 lbs., 8 oz.	Use with Nos. 927 and 938 Push-Pullers, 1155 and 1156 slide hammer pullers, or 24832 puller screw.
1165	3"-9"	5-7/8"	1-1/2"-12	1"-14	13 lbs., 8 oz.	Use with No. 939 Push-Puller.
1154	1-1/2"-9"	4"	1"-8	5/8"-18	4 lbs., 8 oz.	Use with No. 1063 hyd. Push-Puller.
1166	3"-9"	5-7/8"	1-1/4"-7	1"-14	13 lbs., 8 oz.	Use with No. 1071 hyd. Push-Puller.

Puller Screws

24832	13-3/4" long	5/8"-18	1 lb.	Use with Nos. 1150, 1151, 1152, and 1153. Acts as a regular forcing screw when threaded directly into the block of pulling attachment.
24833	5-1/2" long	5/8"-18	6 oz.	Use with Nos. 1150, 1152, and 1153. Acts as a regular forcing screw when threaded directly into the block of pulling attachment.



A = Thread of tapped hole in adapter.
B = Internal thread of tapped cross block.

Metric Adapter Sets*

No. 8110-8140 Add metric capability to your Push-Puller legs or forcing screws! Four different sets to choose from. A storage/organizer case is included with each set.

Tool No.	Internal End	External End	Length
8111	5/8"-18	M6 x 1.0	2-1/4"
8112	5/8"-18	M8 x 1.0	2-1/4"
8113	5/8"-18	M8 x 1.25	2-1/4"
8114	5/8"-18	M10 x 1.25	2-1/4"
8115	5/8"-18	M10 x 1.5	2-1/4"
8116	5/8"-18	M12 x 1.25	2-1/4"
8117	5/8"-18	M12 x 1.75	2-1/4"
8121	5/8"-18	M14 x 1.5	2-1/4"
8122	5/8"-18	M14 x 2.0	2-1/4"
8123	5/8"-18	M16 x 1.5	2-3/4"
8124	5/8"-18	M16 x 2.0	2-3/4"
8125	5/8"-18	M20 x 1.5	2-3/4"
8126	5/8"-18	M20 x 2.5	2-3/4"
Tool No.	Std. End	Metric End	Length
8131	5/8"-18	M6 x 1.0	1-5/8"
8132	5/8"-18	M8 x 1.25	1-5/8"
8133	5/8"-18	M10 x 1.5	1-5/8"
8134	5/8"-18	M12 x 1.75	1-5/8"
8135	5/8"-18	M14 x 2.0	1-5/8"
8136	5/8"-18	M16 x 2.0	1-5/8"
8137	5/8"-18	M20 x 2.5	1-5/8"
Tool No.	Female End	Male End	Length
8141	1"-14	M16 x 1.5	3"
8142	1"-14	M16 x 2.0	3"
8143	1"-14	M18 x 1.5	3"
8144	1"-14	M20 x 1.5	3"
8145	1"-14	M20 x 2.5	3"
8146	1"-14	M22 x 1.5	3"

NOTE: The adapters in each of these sets are also available separately.

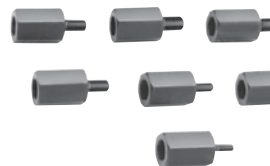

No. 8110 – External/internal metric adapter kit. Wt., 3 lbs.



No. 8120 – External/internal metric adapter kit. Wt., 3 lbs.

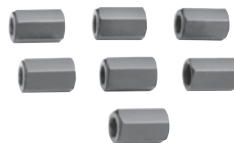

No. 8130 – External/internal adapter kit. Wt., 2 lbs., 12 oz.

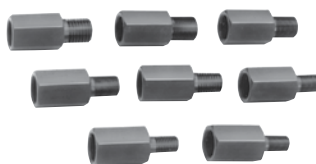

No. 8140 – External/internal metric adapter kit. Wt., 5 lbs., 5 oz.



PULLERS

External-Internal Threaded Adapters

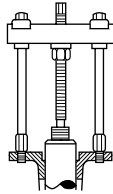

External-Internal Threaded Adapters

For use on the ends of Push-Puller legs or forcing screws when pulling shafts, bearing caps, pinions, etc.

Tool No.	Internal End	External End	Length
206437	1/2"-20	5/8"-18	2-1/4"
8000	5/8"-18	1/4"-20	2-1/4"
8001	5/8"-18	5/16"-18	2-1/4"
8002	5/8"-18	7/16"-14	2-1/4"
8003	5/8"-18	7/16"-20	2-1/4"
8004	5/8"-18	3/8"-24	2-1/4"
8005	5/8"-18	3/8"-16	2-1/4"
8006	5/8"-18	1/2"-20	2-1/4"
8007	5/8"-18	1/2"-13	2-1/4"
8008	5/8"-18	9/16"-18	2-1/4"
8009	5/8"-18	9/16"-12	2-1/4"
8010	5/8"-18	5/8"-11	2-1/4"
8013	5/8"-18	3/4"-16	2-1/4"
8015	5/8"-18	3/4"-10	2-1/4"
8017	5/8"-18	7/8"-14	2-1/4"
8018	5/8"-18	7/8"-9	2-1/4"

Tool No.	Internal End	External End	Length
8019	5/8"-18	1"-14	2-1/4"
8022	5/8"-18	1/8" pipe	2-1/4"
8012	1"-14	5/8"-18	3-3/16"
8011	1"-14	5/8"-11	2-1/2"
8014	1"-14	3/4"-16	2-1/2"
8016	1"-14	3/4"-10	2-1/2"
8020	1"-8	5/8"-18	3"
8021	1"-8	1"-14	3"
8023	1-1/4"-12	1"-14	4-1/2"
8024	1-1/4"-12	1-3/4"-12	4-3/4"
8025	1-1/4"-7	5/8"-18	4"
8027	1-1/4"-7	1"-14	4"
8029	1-5/8"-5/2	1"-14	4"
8028	1-5/8"-5/2	1"-8	4"
8030	3/4"-16	5/8"-18	2-1/4"

Internal Threaded Adapter Set

For use on the ends of Push-Puller legs or forcing screws to aid in the removal and installation of shafts, axles, and housings.

No. 8044 – Internal adapters. Wt., 3 lbs.

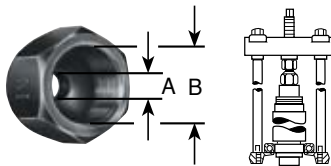

Tool No.	Internal End "A"	Internal End "B"
8035*	1/2"-20	5/8"-18
8036*	1"-14	1"-14
8037	5/8"-18	5/8"-18
8038	5/8"-18	3/4"-16
8039	5/8"-18	7/8"-14

Tool No.	Internal End "A"	Internal End "B"
8040	5/8"-18	1"-14
8041	5/8"-18	1-1/8"-12
8042	5/8"-18	1-1/4"-12
8043*	5/8"-18	1-1/2"-12

*Not included in set No. 8044. Order separately. All adapters are available separately.

Step Plate Adapter Sets

Necessary for pulling and installing bearings, gears, or other parts found on hollow shafts or housings. They may be used with Grip-O-Matic® pullers and Push-Pullers®, as well as shop presses. All adapters are available separately.

No. 8074 – Wt., 1 lb., 5 oz.

No. 8075 – Wt., 5 lbs., 5 oz.

No. 8076 – Wt., 10 lbs., 6 oz.

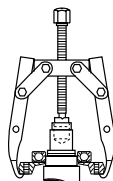

Tool No.	Set No.	Set No.	Set No.	Dia. "A"	Dia. "B"
	8074	8075	8076		
8057	•	•		1"	3/4"
8058				1-1/8"	7/8"
8059	•	•		1-1/4"	1"
8060	•	•		1-3/8"	1-1/8"
8061	•	•		1-5/8"	1-1/4"
8062	•	•		1-3/4"	1-3/8"
8063				1-7/8"	1-1/2"
8064				2"	1-5/8"
8065		•		2-1/8"	1-3/4"

Tool No.	Set No.	Set No.	Set No.	Dia. "A"	Dia. "B"
	8074	8075	8076		
8066				2-3/8"	1-7/8"
8067		•		2-1/2"	2"
8068			•	2-5/8"	2-1/8"
8069			•	2-3/4"	2-1/4"
8070			•	2-7/8"	2-3/8"
8071			•	3"	2-1/2"
8072			•	3-1/4"	2-3/4"
8073			•	3-1/2"	3"

Shaft Protector Set

Designed to protect shaft centers from distortion when extreme pressures are applied with either Grip-O-Matic® pullers or Push-Pullers. Shaft protectors are available separately.

No. 8056 – Shaft protectors. Wt., 1 lb., 2 oz.

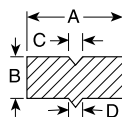
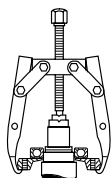

Tool No.	"A"	"B"	"C" (60°)	"D" (60°)
8050	1-1/2"	3/4"	3/8"	7/16"
8051	1-1/4"	3/4"	3/8"	1/4"
8052	1"	3/4"	3/8"	5/16"

Tool No.	"A"	"B"	"C" (60°)	"D" (60°)
8053	3/4"	3/4"	1/4"	1/4"
8054	5/8"	5/8"	1/4"	1/4"
8055	5/8"	5/8"	3/16"	3/16"

Reversible-Jaw Slide Hammer Pullers

Here are two extremely versatile pullers, which will accomplish many pulling jobs involving gears, bearings, outer races, grease retainers, oil seals, etc. Either two or three puller jaws may be used to handle "inside" pulling jobs such as bearing cups and outer races, as well as regular "outside" pulling jobs. The basic slide hammer unit can be removed and used independently. The No. 1177 slide hammer puller has a 5 lb. hammer, and the No. 1176 has a 2-1/2 lb. hammer.

No. 1176 – Puller with 2-1/2 lb. hammer, 2-way and 3-way head, 27" long. Wt., 8 lbs.

No. 1177 – Same as 1176, except has a 5 lb. hammer. Wt., 10 lbs., 8 oz.



2-Jaw Spread				3-Jaw Spread				Overall Length
Inside Min.	Inside Max.	Outside Min.	Outside Max.	Inside Min.	Inside Max.	Outside Min.	Outside Max.	
1-1/4"	3-1/2"	1"	4-1/2"	1-1/2"	4-1/4"	1-1/2"	4-1/2"	27"

Slide Hammer Pullers with Cup Pulling Attachments

These pullers combine a basic slide hammer unit with a No. 1152 internal pulling attachment (described on page 211). Ideal for removing bearing cups, outer races, and oil seals from blind holes. Upon removal of the internal pulling attachment, the basic slide hammer unit, which has a 5/8"-18 threaded end, may be used with various adapters for a multitude of pulling jobs.

No. 1157 – Slide hammer puller, consisting of an 1152 internal pulling attachment and an 1156 basic slide hammer unit with a 2-1/2 lb. hammer. Wt., 9 lbs., 12 oz.

No. 1158 – Slide hammer puller (not shown), consisting of an 1152 internal pulling attachment and an 1155 basic slide hammer unit with a 5 lb. hammer. Wt., 12 lbs., 4 oz.

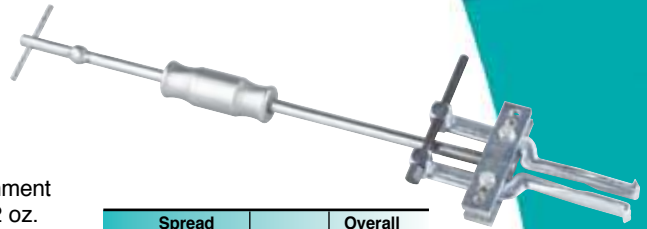

Spread		Reach	Overall Length
Min.	Max.		
1-5/8"	6"	4"	28"

Basic Slide Hammer Units

May be used with an OTC internal pulling attachment (page 211), or with internal or external-internal threaded adapters (page 212).

No. 1155 – Basic slide hammer unit is 24" long with a 5 lb. hammer and a 5/8"-18 threaded end. Wt., 7 lbs., 4 oz.

No. 1156 – Basic slide hammer unit is 24" long with a 2-1/2 lb. hammer and a 5/8"-18 threaded end. Wt., 4 lbs., 12 oz. (not shown)

No. 6501 – Basic slide hammer unit is 17" long with a 1-3/4 lb. hammer and a 1/2"-20 threaded end. Wt., 3 lbs.

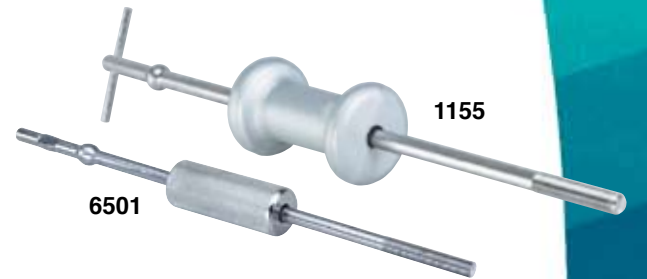

Pilot Bearing Pullers

These very versatile pullers are built specially for inside pulling jobs, and particularly for removing flywheel pilot bearings on automobiles, trucks, and tractors. Also very practical for pulling motor, generator, and magneto bearings.

Tool No.	Reach	I.D. Spread		Wt. (lbs./oz.)
		Min.	Max.	
1170	3/4"	1/2"	1-1/2"	4 / 14
1171	1"	7/8"	2-1/8"	4 / 14
1172	1-3/4"	1/2"	2"	4 / 14

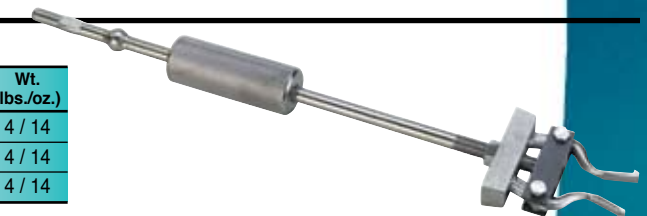

Special Slide Hammer Puller

Ideal for pulling jobs in very close quarters, as in removal of small-bore bushings, bearings, oil seals, etc. Internal pulling attachment has a jaw spread of 1/2" to 1-3/8", adjusted by turning the slide hammer handle. Handle end has a 1/2"-20 thread.

No. 1173 – Slide hammer puller with head assembly. Wt., 3 lbs., 8 oz.

No. 1174 – Head assembly only. Wt., 10 oz.



Slide Hammer Puller

Just 8-1/2" long to fit into tight spots, but its 1-1/2 pound hammer gives you a little extra muscle for stubborn jobs. It's perfect for pulling injector nozzles. The shank is threaded 1/2"-20 and has a 5/8"-18 threaded adapter included. Works with many OTC pulling attachments.

No. 5028 – Slide hammer puller. Wt., 2 lbs.



5028

PULLERS

Grip Wrench Adapters & Bearing Pullers



7703

Ten-Pound Slide Hammer Puller

This heavy-duty slide hammer puller gets tough with those really stuck parts. It has all the features of our smaller versions – heat treated, 24" long, and a 5/8"-18 threaded end to adapt to any of OTC's pulling attachments. The difference is the ten-pound hammer that gives you the extra muscle for really stubborn pulling jobs.

No. 7703 – Ten-pound slide hammer puller. Wt., 12 lbs., 5 oz.



22185

34331

Sliding Hammers

No. 22185 – 2-1/2 lb. sliding hammer.

No. 34331 – 5 lb. sliding hammer.



Grip Wrench Adapters

For grip wrenches using single- or double-lead thread adjusting screw. Adapter threads onto a slide hammer with a 5/8"-18 thread. Grip wrench threads onto a 7/16"-14 end of adapter for pulling use.

No. 205378 – Grip wrench adapter with single lead thread. Wt., 4 oz.

No. 218875 – Grip wrench adapter with double lead thread. Wt., 4 oz.



464

465

OTC "GripLock" Pullers

Manufactured to our rigorous specifications to ensure the quality professionals expect from OTC

- Pressure bearing yoke cap holds jaws in place for ease of set up - in any orientation.
- 2 or 3 Jaw application.
- Both External and Internal Pulling Action.
- "Live Center" action forcing screw.
- Professional finished for long lasting durability...

No. 464 – Puller with a 4" maximum reach, 3" to 4" spread. Wt., 3 lb., 4 oz.

No. 465 – Puller with a 7" maximum reach, 3" to 7" spread. Wt., 7 lb., 13 oz.

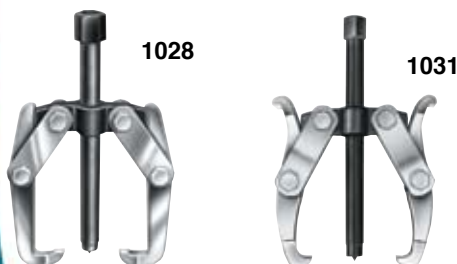

1028

1031

Differential Bearing Pullers

For removing differential side carrier bearings on a wide variety of passenger cars and light trucks. Use with step plate adapter Nos. 8060, 8061, 8063, and 8064. (Step plate adapters are not included with 1028 or 1031. See page 212.)

No. 1028 – Puller with a 3-1/2" maximum reach, 1-1/4" to 4-1/2" spread. Primarily for servicing Ford products. Wt., 1 lb., 13 oz.

No. 1031 – Puller with a 3-1/4" maximum reach, 6" maximum spread. For servicing most General Motors, American Motors, and Chrysler products. Wt., 2 lbs.



4520

Differential Side Bearing Pullers

- Use to remove differential side carrier bearing. Works on a wide variety of cars and light-duty trucks.
- Includes four step plate adapters to fit carrier bearings.
- Reach: 1-5/8". Spread: 2-5/8" to 3-3/8". Forcing screw is 3/4"-16 mm x 6-11/16" lg.

Set includes:

Part No. Description

4520-1 Forcing Screw / Cross Block Assembly

4520-2 Puller Jaws / Pins (set of two each)

4520-3 Puller Jaws Retaining Yoke

4520-4 Step Plate Adapters (set of four)

15/16" – 1-11/32" diameter

1-1/8" – 1-1/2" diameter

1-1/4" – 1-5/8" diameter

1-1/8" – 1-3/4" diameter

No. 4520 – Differential side bearing puller. Wt., 4 lbs., 10 oz.

Specifications

Reach: 1-5/8"

Spread: 2-5/8" on inside holes in crossbar
3-3/8" on outside holes in crossbar

Forcing screw: 3/4"-16 mm x 6-11/16" lg.

Adapter sizes: 15/16" to 1-3/4" diameter

Multipurpose Puller Set

This assortment of puller tools gives you a wide range of job versatility. You get a 5 lb. slide hammer puller, hub puller, two sizes of OTC Grip-O-Matic® jaw-type pullers, a bearing pulling attachment, plus a cross-bar gear and pulley puller, all contained in a handy plastic storage case.

No. 1181 – Multi-purpose puller set. Wt., 25 lbs.

Set No. 1181 consists of:	
No.	Description
1177	Slide hammer puller with a 5 lb. hammer, 2-way and 3-way heads. Reversible: either two or three jaws may be used to handle both "inside" and "outside" pulling jobs.
7208A	Front hub puller for servicing front-wheel-drive cars. Includes a spare locknut, which permits use with a No. 1177 slide hammer for rear axle flanges.
1023	2-ton combination 2- or 3-jaw Grip-O-Matic puller. Has 3-3/8" max. reach, 4-3/4" max. spread.
1027	5-ton combination 2- or 3-jaw Grip-O-Matic puller. Has 5-1/2" max. reach, 7" max. spread.
7393	Bar-type gear and pulley puller with a 5-1/2" long screw. Includes two hex head cap screws, 3/8"-16 x 3" long. Spread range: 1-1/2" to 4-1/4".
1122	Bearing pulling attachment for use with No. 1027 and No. 7393 pullers. Has 2" max spread, 1/8" min. spread.

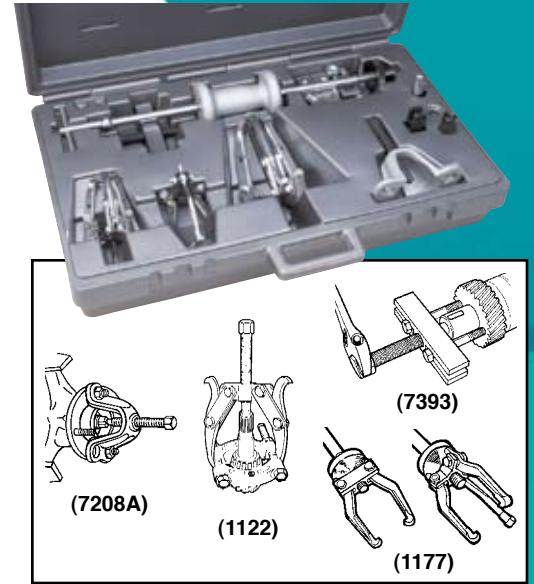

Cone-type Puller

Reversible jaws permit handling of both internal and external pulling jobs. The 2-way/3-way head permits assembly of puller to suit the job at hand. Turning the cone on the puller head securely locks its jaws on the part to be removed.

Puller reach: 2-7/8"

2-jaw spread:

Inside: 1-1/2" to 4-1/2"

Outside: 3/4" to 5"

3-jaw spread:

Inside: 1-1/2" to 4-3/4"

Outside: 1" to 4-1/2"

No. 1184 – Cone-type puller. Wt., 2 lbs., 6 oz.



Bearing Cup Remover

Ideal for servicing hubs on today's popular front-wheel-drive small cars. The cone holds the jaws in place during pulling. No. 7136 is perfect for pulling internal bearing cups, seals, bushings, etc. Jaw spread: 15/16" to 3-1/4", reach to 3-1/2". Use with any slide hammer having a 5/8"-18 thread (OTC No. 1155 or No. 1156 or the No. 927 Push-Puller).

No. 6542 – Universal bearing cup remover. Wt., 1 lb., 8 oz.

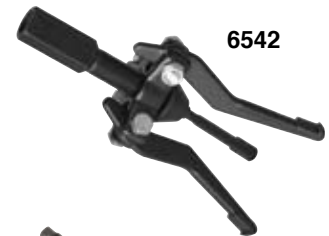

Pilot Bearing Pullers

Designed to pull flywheel pilot bearings in close quarters where a slide hammer cannot be used. Operates on many models with engine in chassis.

No. 7318 – Pilot bearing puller. Capacity: 1/2" to 1-1/2". I.D. reach: 3/4". Wt., 3 lbs., 7 oz.

No. 7319 – Pilot bearing puller. Capacity: 7/8" to 2". I.D. reach: 1". Wt., 3 lbs., 8 oz.

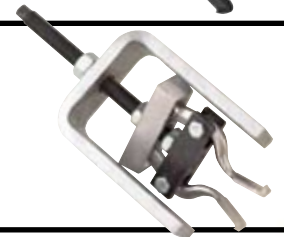

"Silver Slapper" 8-Way Slide Hammer Puller Set

You can pull flange-type rear axles, stubborn oil seals and bearings, and other press-fit parts. Jaws can be set up for 2/3-way internal or external pulling jobs.

No. 1179 – 8-way slide hammer puller set with a 5 lb. hammer and attachments. Wt., 12 lbs.

Set No. 1179 consists of:

No.	Description
1155	Slide hammer w/5 lb. hammer
7372	Rear axle pulling attachment
24544	3-way cross-head
24545	Cone
27241	2-way cross-block
27315	Puller hook attachment
34698	Pulling jaws (3) for internal or external pulling jobs
205378	Grip wrench adapter w/single lead (wrench not included)
205377	Dent puller attachment

Application Examples

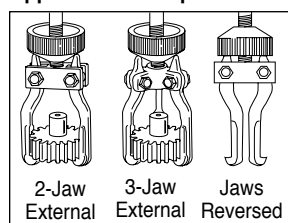

1179

PULLERS

Slide Hammer Puller Sets



7792

Rear Axle Puller Set

The tools you need for flange-type rear axle and bearing removal on most late model passenger cars and light trucks. Set includes the No. 7374 rear axle pulling plate and a 5 lb. slide hammer. The axle bearing pullers, used with the slide hammer, make short work of removing semi-floating rear axle bearings.

No. 7792 – Rear axle puller set. Wt., 11 lbs., 4 oz.

Set No. 7792 consists of:

No.	Description
7374	Rear axle pulling plate with a 5 lb. slide hammer.
7495	Rear axle bearing puller. Fits a min. bearing tube I.D. of 1" and a max. axle tube I.D. of 1-7/8".
7496	Rear axle bearing puller. Fits min. bearing tube I.D. of 5/16" and max. axle tube I.D. of 2-3/8".
7497	Rear axle bearing puller. Fits min. bearing tube I.D. of 1-3/8" and max. axle tube I.D. of 2-7/8".
27315	Puller hook for use with 5 lb. slide hammer in set. Removes oil seals, bearings, etc.

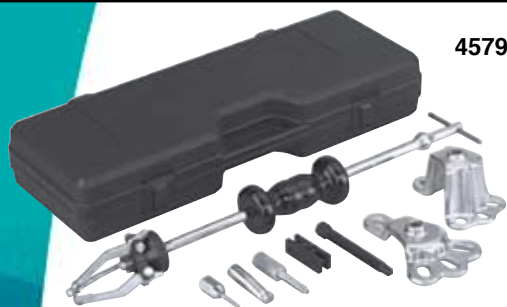

4579

9-Way Slide Hammer Puller Set

Pulls flange type rear axles and most front wheel drive hubs.

- Internal and external jaws provide a variety of combinations to pull bearings, gears and seals.
- Two and three way cross blocks and cone provide the perfect jaw configuration for most jobs.
- Set also includes a grip wrench adapter and a dent puller attachment for sheet metal or other unique pulling requirements.

No. 4579 – 9-Way Slide Hammer Set.



7948

8-Way and 10-Way Slide Hammer Puller Sets

Our two most popular slide hammer puller sets—the Silver Slapper and the Silver Slapper Plus—now come packaged in a convenient plastic, blow-molded carrying/storage case. They're the same great sets with the same versatile pullers and attachments, now made even better with the addition of an organizer case. Or, if you already own either our No. 1179 or No. 1189 puller sets, we offer the plastic case separately. The case will hold either set.

No. 7947 – Eight-way slide hammer puller set. Same contents as No. 1179 Silver Slapper set, but includes plastic carrying/storage case. Wt., 19 lbs.

No. 7948 – Ten-way slide hammer puller set. Same contents as No. 1189 Silver Slapper Plus set, but includes plastic carrying / storage case. Wt., 25 lbs.

No. 63106 – Puller storage case. Blow-molded plastic. Wt., 7 lbs.



1178

Slide Hammer Puller Set

This useful set contains OTC's popular No. 1176 reversible-jaw slide hammer puller, plus an assortment of special jaws and adapters. You get all the versatility of the No. 1176 (described fully on page 213), plus attachments for pulling various size pilot bearings, oil seals, bushings, timing gears, harmonic balancers, and other tightly fitted parts!

No. 1178 – Slide hammer puller set. Wt., 10 lbs., 3 oz.

No. 1178 set consists of:

No.	Description
1176	Reversible-jaw slide hammer puller with 2-1/2 lb. hammer
44195	Medium jaw (3 incl.)
32054	Pilot bearing jaw (3 incl.)
44148	Long jaw (3 incl.)
27315	Puller hook. Removes oil seals, bearings, etc.
27241	2-way cross head
36578	Cross block. Removes timing gears, harmonic balancers, pulleys, other parts having tapped holes. Uses cap screws up to 3/8" diameter. Spread with 3/8" dia. cap screws: 1-7/8" – 5-5/8".

Tool No.	2-Jaw Spread				Tool No.	3-Jaw Spread			
	Inside Min.	Inside Max.	Outside Min.	Outside Max.		Inside Min.	Inside Max.	Outside Min.	Outside Max.
44195	1-1/2"	4-1/2"	3/4"	5"	44195	1-1/2"	4-3/4"	1"	4-1/2"
32054	3/4"	2-3/8"	–	–	32054	1"	2-3/4"	–	–
44148	2-3/4"	5-1/2"	3/4"	7-1/2"	44148	3-1/4"	6-1/4"	1"	6-1/4"
34698	1-1/4"	3-1/2"	1"	4-1/2"	34698	1-1/2"	4-1/4"	1-1/2"	4-1/2"

Blind Hole Puller Set

This set provides a complete selection of expanding collets ranging in size from 5/16" to 1-3/4". Collet is placed through bore of part to be removed, then expanded with actuator pin so that lips of collet secure a positive grip for pulling. Force is exerted by means of a forcing screw and a bridge assembly or a slide hammer. Individual pieces can be ordered separately.

No. 981 – Blind hole puller set. Wt., 21 lbs.



Set No. 981 consists of:

No.	Description
24835	Forcing screw
24836	Forcing screw nut
22185	2-1/2 lb. hammer
208627	Shank and tee bar assembly
28250	Actuator pin, 1/8" dia., for use with collets 33856 & 33857

No.	Description
28253	Actuator pin, 3/16" dia., for use w/collets 33858-33862
28256	Actuator pin, 1/2" dia., for use with collets 33863-33865
28323	Metal box (not shown)
33856	Collet 5/16" to 3/8"

No.	Description
33857	Collet 3/8" to 7/16"
33858	Collet 7/16" to 1/2"
33859	Collet 1/2" to 5/8"
33860	Collet 5/8" to 3/4"
33861	Collet 3/4" to 7/8"

No.	Description
33862	Collet 7/8" to 1"
33863	Collet 1" to 1-1/4"
33864	Collet 1-1/4" to 1-1/2"
33865	Collet 1-1/2" to 1-3/4"
41331	Bridge

Blind Hole Bearing Puller Set

- For pulling jobs requiring an internal pull.
- Set includes four collets, which fit a wide range of applications. Select the appropriate sized collet by comparing it with the application. Insert the collet, expand it to fit the hole, then attach the slide hammer.
- Four collet sizes: 7/16" to 1/2", 9/16" to 11/16", 5/8" to 1", and 1" to 1-1/4".
- Set includes a 2-1/2 lb. slide hammer with a T-handle.
- Housed in a blow-molded plastic storage case.

No. 4581 – Blind hole bearing puller set. Wt., 7 lbs., 2 oz.

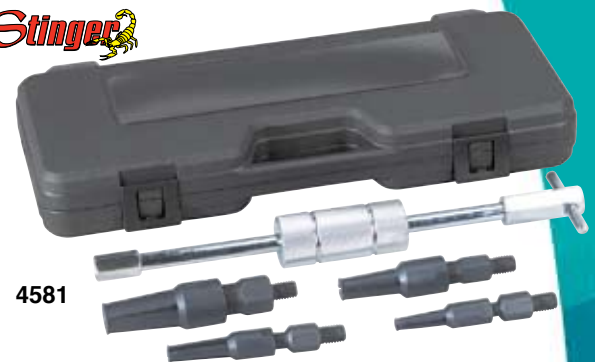

A/C Clutch Pulley Puller Set

- For removal of stubborn air conditioning clutch pulleys. Also can be used on many alternator, generator, power steering, and crankshaft pulleys, harmonic balancers, and fiber timing gears.
- Set includes drop-forged components: one 3/4"-16 x 5" live center forcing screw, 5-1/2" crossbar with 3 spread settings, two pairs of jaws, and a clamp bolt.
- Spread: 3" to 5"; Reach: 1" to 5".
- Includes a blow-molded plastic case.

No. 4536 – A/C clutch pulley puller set. Wt., 4 lbs., 11 oz.



Multipurpose Bearing and Pulley Puller Set

- For a wide range of pulling jobs, including: bearings, alternators, generators, power steering and crankshaft pulleys, timing gears, and harmonic balancers.
- Set includes drop-forged components, which can be used in a variety of combinations.

Contents of Set:

- 2 – Forcing Screws (live center): 3/4"-16 x 6-11/16" & 3/4"-16 x 5"
- 2 – Cross-bar Yokes: 3 pin-hole @ 3-1/4" to 5-1/2", 2 pin-hole @ 2-3/8" to 3-3/8"
- 2 – Clamp Bolts
- 3 – Pairs of Puller Jaws: 1-3/8" Max, 1-5/8" Max, 1-3/4" Max
- 1 – Pair of Jaw Pins with Ball Spring
- 3 – Pairs of Capped Bolts

• Spread: 3" to 5", Reach: 1" to 2-1/4"

• Housed in a blow-molded plastic storage case.

No. 4534 – Multipurpose bearing and pulley puller set. Wt., 8 lbs., 2 oz.



PULLERS

Puller/Bearing Sets



1182

Lock-on, Jaw-type Puller Set

Components can be assembled to create several versatile puller versions for both internal and external pulling tasks. The puller head is turned to securely lock the jaws onto the part being removed. Both a 2-way and 3-way puller head are included, plus three long-reach and three short-reach puller jaws. Plastic storage box included. Easily removes gears, bearings, timing gears, harmonic balancers, and other press-fitted parts.

No. 1182 – Jaw-type puller set. Wt., 6 lbs., 10 oz.

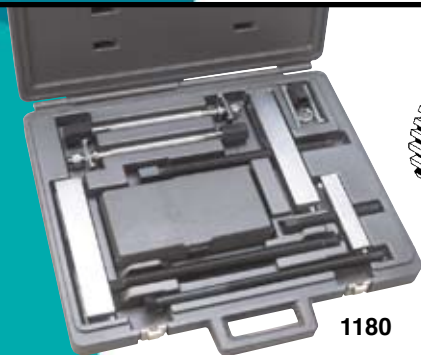

1180

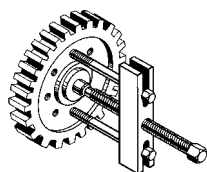

10-Ton Capacity Push-Puller Set

Contains three popular OTC bar-type pullers in one versatile set, packed in a handy plastic storage case. Tools included permit damage-free pulling of gears, bearings, harmonic balancers, and other parts having tapped holes. Ideal for servicing heavy-duty trucks, off-road construction equipment, and machinery.

No. 1180 – 10-ton push-puller set, in plastic case. Wt., 25 lbs.

Set No. 1180 consists of:

No.	Description
927	10-ton Push-Puller, 8-3/8" reach, 2-1/8" to 7-1/4" spread. 6-3/4" puller legs. Other leg sizes are available separately. (See pages 209–210.)
522	Gear and pulley puller; spread range when used with 1/2" cap screws: 2" to 7-3/4". Cap screws not included.
7393	Gear and pulley puller with standard 5-1/2" forcing screw, plus special 13" forcing screw. Includes two hex head cap screws, 3/8"–16 x 3" long. Special range: 1-1/2" to 4-1/4".



1183

Bearing Splitter Combo Set

This combo pack contains four of OTC's most popular bearing splitters, plus a pulley pulling attachment. A rugged organizer case is included, enabling you to keep the tools together for instant use.

Set No. 1183 consists of:

No.	Description
1121	Bearing splitter. Has 15/16" max. spread and 1/4" min. spread.
1122	Bearing splitter. Has 2" max. spread and 1/8" min. spread.
1123	Bearing splitter. Has 4-5/8" max. spread and 1/2" min. spread.
1130	Bearing splitter. Has 9" max. spread and 1/2" min. spread.
679	Pulley pulling attachment with a 5-7/8" max. and 1-3/4" min. spread

No. 1183 – Bearing splitter combo set. Wt., 30 lbs., 5 oz.

No. 62885 – Organizer case only (for 1183). Wt. 5 lbs., 5 oz.



4518

5-Ton Bar-type Puller/Bearing Separator Set

- This combination set includes our two most popular bearing "splitters" (2" and 3"), four sets of hex push-puller legs, and a bar-type puller head with a 9/16" forcing screw. Separator tools are used with bar puller and legs for a wide variety of pulling jobs.
- The 5" puller cross-bar with a 6-1/4" forcing screw and each of the bearing separators may be used separately or in combination with other pullers or tools.
- A blow-molded plastic storage case keeps set contents organized and protected from loss.

No. 4518 – Bearing separator/bar-type puller set. Wt., 10 lbs., 8 oz.

Flange-Type Puller Combination

Two specialty pullers in one box. You get a flange-type puller for removal of harmonic balancers, timing gears, and other parts with two or three tapped holes. You also get a steering wheel, pulley, and flywheel puller.

No. 525 – Flange-type puller combination. Includes flange-type puller and steering wheel puller with four sets of cap screws. Wt., 5 lbs., 8 oz.

525



Flange-Type Puller

Heavy-duty flange puller features a live center forcing screw. Includes two live center forcing screw tips and two sets of commonly used automotive bolts. Puller will work on bolt circles from 1-1/2" to 4-1/4". Three cap screws, 3/8-24 x 3" long, and three cap screws, 3/8-16 x 3" long.

No. 6930 – Flange-type puller. Wt., 3 lbs., 4 oz.

6930



7-Ton Capacity Four-In-One™ Puller Set

With the parts included in the PA7, you can quickly assemble a 2/3-jaw puller with standard or long reach. 7-ton capacity, the max. reach of 8-3/4", and max. spread of 11" make it ideal for hundreds of pulling jobs.

No. PA7 – Four-in-one puller set, 7-ton cap. Standard jaw max. reach: 5". Max. spread: 10-1/2". Long jaw max. reach: 8-3/4". Max. spread: 11". Wt., 12 lbs.

PA7



Flange-Type Puller Set

Covers almost every car, pick-up, SUV, and small engine. Capable of handling almost every two- or three-way bolt pull possible. For use on a variety of jobs: harmonic balancers, steering wheels, crankshaft pulleys, and gears. Storage tray and detailed application chart included. Slotted holes in puller flange permit cap screws to be positioned to handle bolt circles from 1-1/2" to 4-1/4".

Includes three each of the following washer head bolts (Grade 8):

M8 x 1.25 x 90 mm	3/8-16 UNF x 3"	M8 x 1.25 x 90 mm
1/4-28 UNF x 3"	M10 x 1.5 x 35 mm	M8 x 1.25 x 60 mm
5/16-24 UNF x 3"	5/16-18 UNF x 3.5"	3/8-16 UNF x 4.5"
3/8-24 UNF x 1.5"	3/8-16 UNF x 2"	

Special Stepped Bolts – 1990 & newer GM 3300–3800 V-6 crankshaft pulleys

No. 6294 – Flange-type puller set. Wt., 7 lbs., 4 oz.

6294



PULLERS

Puller Sets

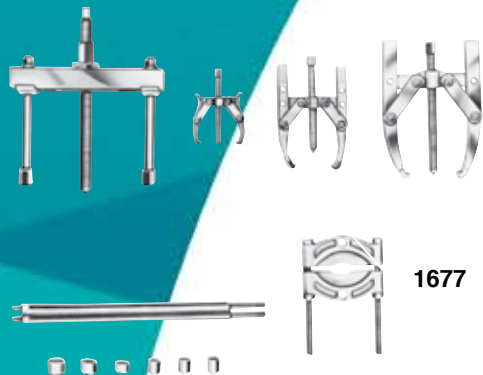

1677

17-1/2 Ton Capacity Puller Set

This puller set gives you the versatility you want and the tonnage capacity you need to tackle parts removal and installation on many models of cars, trucks, tractors, power shovels, road building machinery, etc. Maintenance operations involving the removal and replacement of gears, bearings, wheels, and other press-fit parts can be done with ease.

No. 1677 – 17-1/2 ton capacity puller set. Wt., 65 lbs.

No. 1621 – Board (3' x 4') for storing No. 1677 set (not included with set). Wt., 37 lbs.

No.	Description	No.	Description
938	Push-Puller w/ 9-1/2" legs		Internal threaded adapters
1104	16-1/2" legs for 938 (pr.)	8037	5/8"-18 x 5/8"-18
1024	2-jaw puller	8038	5/8"-18 x 3/4"-16 (2)
1036	2-jaw puller	8039	5/8"-18 x 7/8"-14
1039	2-jaw puller	8040	5/8"-18 x 1"-14
1130	Bearing splitter	8041	5/8"-18 x 1-1/8"-12
		8043	5/8"-18 x 1-1/2"-12

13-Ton Capacity Puller Set

This versatile 13-ton capacity puller set removes gears, bearings, shafts, pinions, bearing outer races, and other tightly fitted parts. The set includes a Push-Puller, Grip-O-Matic® pullers, bearing pulling attachments, specialized pullers, and many accessories. You can work on all makes and models of cars and light trucks with this set.

No. 1675 – 13-ton capacity puller set. Wt., 74 lbs.

No. 1620 – Board (3' x 4') for storing No. 1675 set (not included with set). Wt., 40 lbs.

No.	Description	No.	Description
927	Push-Puller w/ 6-3/4" legs	1176	Slide hammer puller
1101	15-3/4" legs for 927 (pr.)	7310A	Pitman arm puller
1022	2-jaw puller	8075	Step plate adapter set
1024	2-jaw puller	8035	Internal threaded adapter: 1/2" -20 x 5/8" -18 (2)
1035	2-jaw puller	8044	Internal threaded adapter set
1039	2-jaw puller	1152	Bearing cup pulling attach.
7392	Gear and pulley puller	1121	Bearing splitter
518	Flange-type puller	1122	Bearing splitter
7403	Steering wheel puller	1123	Bearing splitter
1170	Pilot bearing puller		

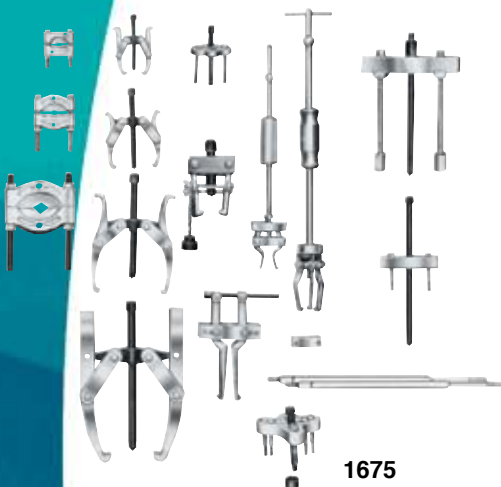

1675

Strong Box Puller Set

Here's a set of pullers that gives you almost unheard of versatility. You get eight pullers, five attachments, and extra puller jaws. They enable you to pull gears, bearings, pulleys, wheels, and more on cars and light trucks. All these tools are contained in a rugged, lockable metal storage cabinet you can either mount on a wall or stand on a work bench, so they are handy when you need them. Just imagine the jobs you can do with this set!

No. 1676 – Strong box puller set. Wt., 85 lbs.

No. 18886 – Storage box only. 29-1/2" wide x 25-3/4" high x 10" deep. Wt., 47 lbs.

No.	Description	No.	Description
1026	2/3-jaw puller	7311A	Pitman arm puller
1037	2/3-jaw puller	1122	Bearing splitter
7393	Gear and pulley puller	1123	Bearing splitter
518	Flange-type puller	7372	Rear axle pulling adapter
7403	Steering wheel puller	43888	Long jaws for No. 1026 (3)
1170	Pilot bearing puller	43892	Long jaws for No. 1037 (3)
1177	Slide hammer puller	18886	Metal storage box



1676

Hydraulic Puller Sets

17-1/2, 30-, and 50-Ton Capacity – Individual items in the sets are fully described elsewhere in this catalog. . . consult index.

No. 1688 – 17-1/2 ton capacity hydraulic puller set. Wt., 139 lbs.

No. 1689 – 30-ton capacity hydraulic puller set. Wt., 330 lbs.

No. 1690 – 50-ton capacity hydraulic puller set. Wt., 576 lbs.

No.	Description	Set 1688	Set 1689	Set 1690
HYDRAULICS				
4002	Single stage hydraulic hand pump assy.	•	•	•
4120	17-1/2 ton ram with threaded insert	•		
4121	30-ton ram with threaded insert		•	
4122	50-ton ram with threaded insert			•
24815	Tee adapter	•	•	•
9650	Pressure gauge	•	•	•
9767	Hydraulic hose – 6 foot	•	•	•
9798	Hose half coupler with dust cap	•	•	•
PULLERS				
1062	17-1/2 ton Push-Puller with 16-1/2" legs	•		
1066	17-1/2 ton 3-jaw hydraulic puller	•		
1070	30-ton hydraulic Push-Puller with 18" legs		•	
1074	30-ton 3-jaw hydraulic puller		•	
1076	50-ton hydraulic Push-Puller with 24" legs			•
1080	50-ton 3-jaw hydraulic puller			•
ACCESSORIES				
1105	Puller leg – 22-1/2"	•		
1111	28" legs for No. 1070		•	
1113	34" legs for No. 1076			•
1127	Bearing pulling attachment		•	•
1130	Bearing pulling attachment	•		
1154	Bearing cup pulling attachment	•		
1166	Bearing cup pulling attachment		•	
201454	Pushing adapter	•		
24814	Speed crank	•		
27198	Speed crank		•	
28228	Pushing adapter	•		
28229	Ram cap		•	
28230	Ram cap for No. 1076			•
29595	Speed crank			•
32118	Ram adjusting screw	•		
32698	Adjusting screw			•
34510	Pushing adapter		•	
34755	Pushing adapter			•
34758	Adjusting screw		•	
41226	2-way head for No. 1074		•	
41224	2-way head for No. 1066	•		
50449	2-way head for No. 1080			•
8020	1"-8 F. x 5/8"-18 M. threaded adpt.	•		
8023	1-1/4"-12 F. x 1"-14 M. threaded adpt. (2)			•
8028	1-5/8"-5-1/2 F. x 1"-8 M. threaded adpt.			•
8029	1-5/8"-5-1/2 F. x 1"-14 M. threaded adpt.			•
8036	Female thd. adpt. 1"-14 x 1"-14 (2)		•	
8038	Female thd. adpt. 5/8"-18 x 3/4"-16 (2)	•		

1688

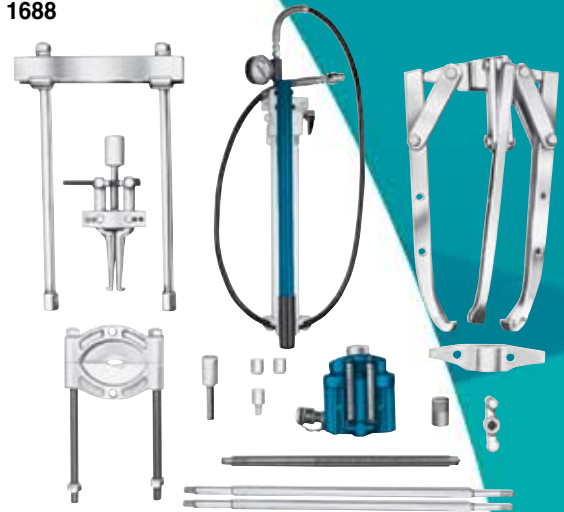

1689



1690

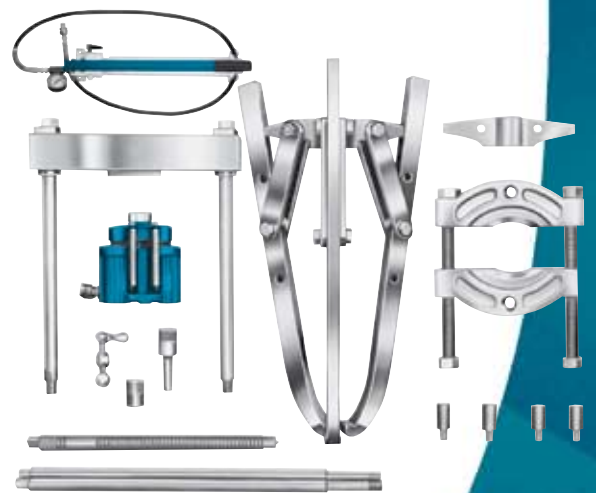

PULLERS

Hydraulic Puller Sets



1679-1683

Photo for illustrative purposes only. For complete set contents, see chart below.

Individual items in the sets are fully described elsewhere in this catalog. . . consult index.

Tool No.	Description	Set 1679	Set 1680	Set 1681	Set 1682	Set 1683
HYDRAULICS						
4002	Single-stage hydraulic hand pump assembly	•	•	•	•	•
4008	2-stage hyd. hand pump w/3-way control valve				•	
9650	Pressure gauge	•	•	•	(2)	•
9798	Hose half coupler w/dust cap	•	•	•	(2)	•
9767	Hydraulic hose – 6 ft.	•	•	•	(2)	•
RAMS						
4120	17-1/2 ton ram with threaded insert	•	•	•	•	•
4121	30-ton ram with threaded insert			•	•	
4122	50-ton ram with threaded insert				•	•
PULLERS						
1025	2-jaw puller		•			
1027	5-ton capacity 2/3-jaw puller	•		•	•	•
1035	2-jaw puller		•			
1039	2-jaw puller		•			
1062	17-1/2 ton cap. hyd. Push-Puller w/16-1/2" legs	•	•	•	•	•
1105	22-1/2" legs for No. 1062 (pair)	•	•	•	•	•
1106	9-1/2" legs for No. 1062 (pair)				•	
1107	4-1/2" legs for No. 1062 (pair)				•	
1070	30-ton cap. hyd. Push-Puller w/18" legs			•	•	
1109	8" legs for No. 1070 (pair)				•	
1111	28" legs for No. 1070 (pair)			•	•	
1076	50-ton cap. hyd. Push-Puller w/24" legs				•	•
1113	34" legs for No. 1076 (pair)				•	•
1066	17-1/2 ton 3-jaw Grip-O-Matic® puller	•	•	•	•	•
41224	17-1/2 ton 2-jaw puller head	•	•	•	•	•
1074	30-ton 3-jaw hyd. puller			•	•	
1080	50-ton 3-jaw hyd. puller				•	•
50449	50-ton 2-jaw puller head			•	•	
1037	Combination 2/3-jaw puller	•		•	•	•

Hydraulic Puller Sets

- No. 1679 – 17-1/2 ton hydraulic puller set. Wt., 238 lbs.
- No. 1680 – 17-1/2 ton hyd. farm implement service set. Wt., 186 lbs.
- No. 1681 – 17-1/2 ton and 30-ton hydraulic puller set. Wt., 543 lbs.
- No. 1682 – 17-1/2 ton, 30-ton, & 50-ton master puller set. Wt., 1260 lbs.
- No. 1683 – 17-1/2 ton & 50-ton hydraulic construction equipment service set. Wt., 821 lbs.

Tool No.	Description	Set 1679	Set 1680	Set 1681	Set 1682	Set 1683
41226	30-ton 2-jaw puller head			•	•	
43892	Long jaws for No. 1037 (3)			•	•	•
1041	Combination 2/3-jaw puller	•		•	•	•
30902	Long jaws for No. 1041 (3)			•	•	•
1170	Pilot bearing puller		•			
1176	Slide hammer puller		•			
7392	Gear and pulley puller		•			•
24833	Short forcing screw for No. 7392		•			•
ACCESSORIES						
8005	5/8"-18 F x 3/8"-16 M threaded adapter (2)	•	•	•	•	•
8006	5/8"-18 F x 1/2"-20 M threaded adapter (2)	•	•	•	•	•
8007	5/8"-18 F x 1/2"-13 M threaded adapter (2)	•	•	•	•	•
8010	5/8"-18 F x 5/8"-11 M threaded adapter (2)	•	•	•	•	•
8013	5/8"-18 F x 3/4"-16 M threaded adapter (2)	•	•	•	•	•
8015	5/8"-18 F x 3/4"-10 M threaded adapter (2)	•	•	•	•	•
8017	5/8"-18 F x 7/8"-14 M threaded adapter (2)	•	•	•	•	
8018	5/8"-18 F x 7/8"-9 M threaded adapter (2)	•		•	•	
8019	5/8"-18 F x 1"-14 M threaded adapter (2)	•	•	•	•	•
8020	1"-8 F x 5/8"-18 M threaded adapter (1)	•	•	•	•	•
8021	1"-8 F x 1"-14 M threaded adapter (1)	•	•	•	•	•
8012	1"-14 F x 5/8"-18 M threaded adapter (2)			•	•	
8025	1-1/4"-7 F x 5/8"-18 M threaded adapter (2)			•	•	
8027	1-1/4"-7 F x 1"-14 M threaded adapter (2)			•	•	
8023	1-1/4"-12 F x 1"-14 M threaded adapter (2)				•	•
8024	1-1/4"-12 F x 1-3/4"-12 M threaded adapter (2)				•	
8028	1-5/8"-5-1/2 F x 1"-8 M threaded adapter (1)				•	•
8029	1-5/8"-5-1/2 F x 1"-14 M threaded adapter (1)				•	•
8036	1"-14 F x 1"-14 F threaded adapter (2)			•	•	
8038	5/8"-18 F x 3/4"-16 F threaded adapter	(2)	•	(2)	(2)	•
8056	Shaft protector set	•	•	•	•	•
8075	Step plate adapter set	•	•	•	•	•
8076	Step plate adapter set	•	•	•	•	•
679	Pulley pulling attachment	•		•	•	
680	Pulley pulling attachment			•	•	
8044	Internal threaded adapter set	•	•	•	•	•
10215	Hex nut: 3/4"-16 (2)					•
1154	Bearing cup pulling attachment	•	•	•	•	•
32136	Long jaws for No. 1154 (2)			•	•	
1166	Bearing cup pulling attachment			•	•	•
34479	Reducing adapter for use with No. 1166				•	•
1122	Bearing splitter	•	•	•	•	•
1123	Bearing splitter	•	•	•	•	•
1126	Bearing splitter			•	•	•
1127	Bearing splitter			•	•	•
1128	Bearing splitter				•	
1130	Bearing splitter	•	•	•	•	•
24814	Speed crank	•	•	•	•	•
24815	Tee adapter	•	•	•	•	•
24829	Short bolt (2)					•
24832	Special puller forcing screw	•		•	•	
27198	Speed crank			•	•	
29595	Speed crank				•	•
28228	Ram cap	•	•	•	•	•
28229	Ram cap			•	•	
28230	Ram cap				•	•
32118	Ram adjusting screw	•	•	•	•	•
32698	Ram adjusting screw				•	•
34758	Ram adjusting screw				•	•
34510	Pushing adapter			•	•	
34755	Pushing adapter				•	•
201923	Pushing adapter	•	•	•	•	•



- Engineered in the U.S.A.
- Lifetime Marathon Warranty®

Sleeve Pullers & Installers **224–225**

Diesel Engine Tools **226–230**

Truck Clutch Tools **231–232**

U-Joint Tools **233**

Wheel Bearing Locknut Sockets **234–236**

Lug Nut Tools **236**

King Pin/Anchor Pin Press **237**

Brake & Steering Tools **237–241**

Suspension Tools **238**

Transmission Tools **241–243**

Fuel & Injector Service **243–245**

Diesel Injection Nozzle Testers **246–248**

Heavy-Duty Class 4 – 8 Trucks

Category	Class	GVWR2	Representative Vehicles
Medium	4	62 - 71 kN (14,001 - 16,000 lbs.)	city cargo van, beverage delivery truck, wrecker, school bus
	5	71 - 87 kN (16,001 - 19,500 lbs.)	
	6	87 - 116 kN (19,501 - 26,000 lbs.)	
	7	116 - 147 kN (26,001 - 33,000 lbs.)	
Heavy	8	147 kN and over (33,00 lbs. and over)	truck tractor, concrete mixer, dump truck, fire truck, city transit bus

HEAVY-DUTY TOOLS

Sleeve Puller / Installer Sets



Sleeve Puller / Installer Sets

These sets work on a wide array of truck, bus, and tractor engines, as well as those in other vehicles. They'll handle wet and dry sleeves – and you won't need to remove head studs. Save time, effort, and money.

- Choice of two sets: manual or 17-1/2 ton hydraulic powered.
- Wide range of adapter plates available to fit most engines.

Manual Sleeve Puller Set

This manually operated, screw-powered device removes cylinder sleeves from most truck, bus, and tractor engines. Adapter plates (not included in the set) accommodate a wide range of bore sizes. See application chart on next page. The puller enables one technician to handle sleeve-pulling tasks.

Not recommended for Mack engines (use No. 1202 set).

No.	Description
24824	Thrust washer
37592	Three-way head
27908	13" risers (3 required)
22205	Forcing nut
208675	Swivel assembly
10088	Cap screws, hex hd. (3)
10586	Flat washers (3)
11466	Thrust bearing
32976	Pulling screw

No. 1200 – Manual sleeve puller set. Wt., 26 lbs.



Installing Conversion Kit for 1200 Set

Permits the No. 1200 sleeve puller to handle both removing and installing operations. Use plate Nos. 1253–1256 for installing, and plate Nos. 1219–1250 for removing. Plates are not included with kit.

No.	Description
33769	Screw extension
41291	Installing bar
302340	Yoke assembly

No. 1201 – Installing conversion kit. Includes screw ext., installing bar, and yoke assembly. Wt., 17 lbs., 13 oz.

SLEEVE PULLER PLATE APPLICATION CHART

The puller plates listed here work with manual and 17-1/2 ton hydraulic sleeve pullers	Bore Dia.	Plate No.
J.I. CASE – 207 Diesel	4"	1227
CATERPILLAR – 1673C; 1674; 3304; 3306; D330C; D333C; D334	4-3/4"	1240
D326, D337	5-1/8"	1246
CUMMINS – V Series 903 NT855	5-1/2"	1250
H & NH	4-7/8"	1242
GENERAL MOTORS – 53 Series	3-7/8"	1225
71 Series	4-1/4"	1232
INT'L HARVESTER – C-221, C-263	3-9/16"	1221
D-166, D-188, D-236, D-282, C-248, D-248, D-310, D-358, D-155	3-11/16"	1222
D-179, D-206, D-239	3-7/8"	1225
C-281, D-281, D-361	4-1/8"	1230
D-691, D-461	4-3/4"	1240
D-407	4-5/16"	1233
JOHN DEERE – 4-270, 6-404	4-1/4"	1232
6-531	4-3/4"	1240
6-619	5.12"	1246
8-955	5.512"	1250
MACK – END(T) 673, 675, 676	4-7/8"	1243
672	4-7/8"	1242
END (T) 711, 707	5"	1245
PERKINS – AD3.152, AG3.152, AD4.203	3.6"	1219
AG4.212, A4.236, AG4.236, A6.354, A6.3541, ATC6.3541, AT6.354, AT6.3541	3-7/8"	1223

Universal puller for wet-type sleeves, see following page.

17-1/2 Ton Hydraulic Sleeve Puller Set

Removes and installs sleeves of many makes and models of trucks, buses, and tractors. See chart at left and on next page.

Contents of Set No. 1202:

No.	Description	No.	Description
37592	Three-way head	27908	13" risers (3 req'd)
33769	Screw extension	41291	Installing bar
302482	Speed nut	10221	Hex safety nut
302340	Yoke assembly	208675	Swivel assembly
10088	Cap screws, hex hd (3)	10586	Flat washers (3)
32976	Pulling screw	21714	Insert
4180	Hyd. ram/pump assy.		

No. 1202 – 17-1/2 ton hydraulic sleeve puller set. Wt., 86 lbs.

No. 1203 – Sleeve puller without hydraulic assembly. Wt., 45 lbs., 10 oz.

Universal Puller for Wet-Type Sleeves

This tool will remove cylinder sleeves faster than ordinary pullers because it requires very little setup time. Cone adjustment positions the puller jaws quickly, locking bar is tightened. To aid in breaking "frozen" sleeves loose, adjustable bridge is positioned on the cylinder block and the bearing-mounted forcing nut is tightened. Next, bridge is removed and slide hammer assembly is attached. With a few sharp hammer blows, sleeve is pulled. In most cases, job time will average less than two minutes per cylinder. The puller features a 5 lb. slide hammer to help bust loose even the most stubborn sleeves.

- Special adapters are unnecessary.
- Adjustable jaws fit sleeves 3" to 6-1/2" in diameter.

No. 1205 – Sleeve puller with 5 lb. slide hammer assembly. Wt., 20 lbs., 10 oz.

No. 1204 – Sleeve puller without 5 lb. slide-hammer assembly. Wt., 14 lbs.

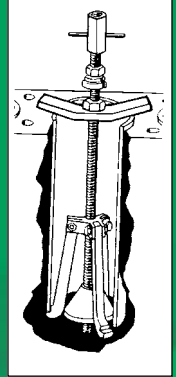

Bore Inches	"A" I.D. +.010 -0.000	"B" O.D. +.015 -0.015	OTC Plate Number
3.600"	3.585	3.657	1219
3-9/16"	3.547	3.663	1221
3-11/16"	3.671	3.792	1222
3-7/8"	3.840	4.047	1223
3-7/8"	3.859	4.093	1225
4"	3.984	4.218	1227
4-1/8"	4.109	4.229	1230
4-1/4"	4.235	4.470	1232
4-5/16"	4.302	4.450	1233
4-3/4"	4.734	5.171	1240
4-7/8"	4.860	4.980	1242
4-7/8"	4.860	5.045	1243
5"	4.977	5.120	1245
5-1/8"	5.093	5.593	1246
5-1/2"	5.484	5.718	1250

Sleeve Removal Plates

Designed to work with set Nos. 1200, 1202, and 1203, these removal plates fit the full spectrum of cylinder sleeve sizes. Determine engine bore size ("A" dimension) and O.D. of sleeve to be pulled ("B" dimension). Then consult chart to the right.

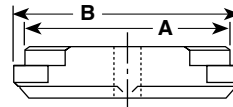

Sleeve Installation Plates

Each of these dry-sleeve installation plates covers a range of bore sizes. Their reversible design makes both sides usable. The plates work with our manual or 17-1/2 ton hydraulic puller/installers (Nos. 1200, 1202, and 1203). Check chart at right to ensure correct sleeve selection.

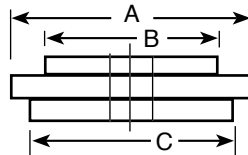

Fits Sleeves From	"A"	"B"	"C"	No.
3-3/16" to 3-7/16"	3-7/8"	3.171"	3.421"	1252
3-9/16" to 3-7/8"	4-1/4"	3.546"	3.859"	1253
4-1/8" to 4-3/8"	4-3/4"	4.109"	4.359"	1254
4-3/8" to 4-3/4"	5-1/4"	4.390"	4.734"	1255
4-13/16" to 5-3/4"	6-3/8"	4.797"	5.734"	1256

Blank Sleeve Remover Plates

These sleeve puller blanks supplement the sleeve puller plates listed above. Should a standard plate be unavailable, you can machine these blanks to the required bore size.

- Includes instructions.

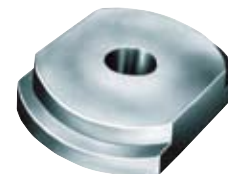
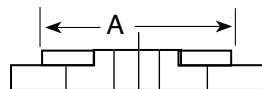

Machined Bore Dim. "A"	Will Machine to Bore Size Dim. "A"	Blank Number
5.250	4.750	39058
4.750	4.400	39057
4.400	3.812	38722
3.812	3.437	38724
3.437	3.000	38723

Oil Seal and Wear Ring Installer

This two-piece tool makes the difficult job of correctly installing the rear crankshaft seal and wear ring on most Navistar DT-360 and DT-466 engines thru 1996 an easy task. Bolt the adapter to the crankshaft and wrench the component home.

- Eliminates damage to seals or wear ring that can occur when driving them into place.

No. 5022 – Oil seal and wear ring installer for 5.0" dia. seals (ZTSE4749 for 6.5" dia.). Wt., 32 lbs.



5022

HEAVY-DUTY TOOLS

Glow Plug / Compression Service



Cylinder Liner Height Gauge with Hold-Down Bar

This set lets you meet those exacting specifications necessary for optimum diesel engine performance. It accurately measures cylinder bore flatness and depth. The hold-down bar correctly seats the liner for accurate measurement of liner protrusion. The easy-to-read dial is in .001 inch graduations, 1.000" range.

No. 7106 – Cylinder liner height gauge with hold-down bar, in plastic case. Wt., 7 lbs., 7 oz.

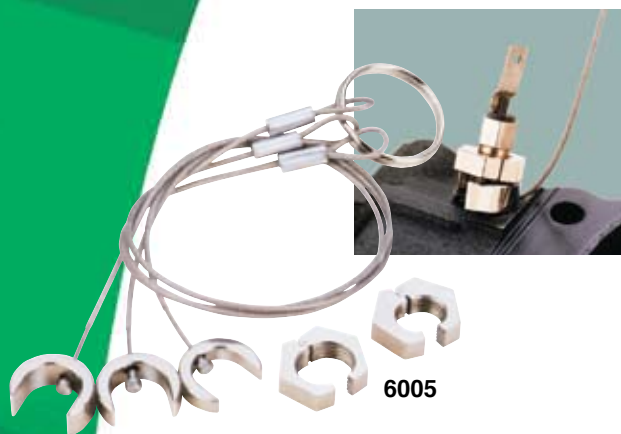

Diesel Glow Plug Removal Tool

- Removes damaged, stuck-in glow plugs on diesel engines without having to remove cylinder head, saving hours of service time!
- When glow plug tip is melted and plug cannot be removed without breaking it off, this tool is the only answer.
- Tool includes 10 mm and 12 mm split nuts that provide added threads for pulling. One of three furnished spacers is installed under split nut to give a solid base for extraction without breaking glow plug off. Split nut is held with a wrench as the glow plug is unscrewed from the head.
- Services diesels in popular 3/4- and 1-ton pickups. Comes in a plastic storage case.

No. 6005 – Includes 10 mm x 1.00 mm and 12 mm x 1.25 mm split nuts, three spacers (3/16", 1/4", 5/16"), plastic storage/organizer case, and instructions. Wt., 5 oz.

Services Ford – 1983-87 6.9L, 1988-98 7.3L, GM – 1992-2000 6.5L, 1982-93 6.2L, 1980-85 5.7L, plus many import and ag. diesel engines

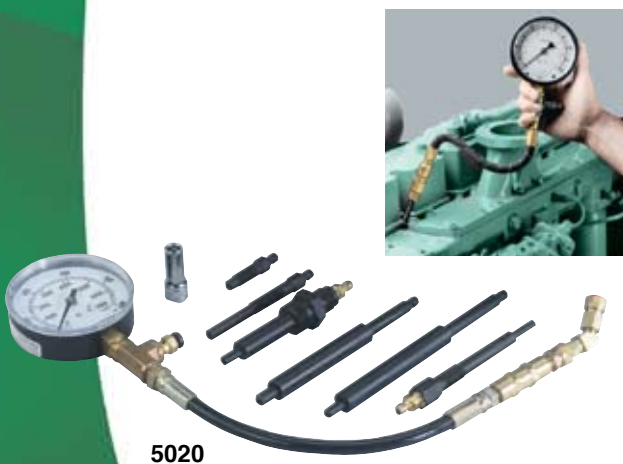

Diesel Compression Tester with Adapters

This easy-to-use compression tester is designed for light- and medium-duty diesel engines equipped with glow plugs. A dual-reading gauge, featuring a push-button release valve, measures compression to 1000 PSI and 7000 kPa. The hose end has quick disconnect fittings. The tester comes with glow plug and nozzle adapters in a handy storage case.

Tester services these engines:

- Cummins B and C
- Navistar DT466/DT360
- Ford/Navistar 6.9L & 7.3L
- Detroit 6.2L & 6.5L
- Hino diesel and Mitsubishi Fuso truck engines

No. 5020 – Diesel compression tester with adapters. Wt., 7 lbs., 13 oz.

No. 5021 – Universal diesel engine compression gauge. Wt., 1 lb., 8 oz.

No. 304802 – Replacement gauge. Wt., 8 oz.

Similar to Ford 303-D091 (D93T-6000-A)

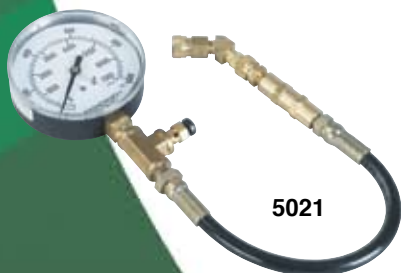

Similar to Ford No. 303-D092 (D93T-6000-B)

Replacement Adapters (available separately)

No. 47484 – Hino diesel truck engines with 12 mm x 1.25 thread

No. 209633 – Ford 6.6L & 7.8L diesels

No. 217791 – Cummins B 3.9L 4 cyl. & 5.9L 6 cyl. '89-'98

No. 308472 – Mitsubishi Fuso truck 4D & 6D engines with 10 mm x 1.25 thread

No. 310810 – Cummins C 8.3L 6 cyl. '88-'96

No. 310832 – Ford/Navistar 6.9L & 7.3L, Detroit 6.2L & 6.5L with 10 mm x 1.0 thread

No. 310840 – Navistar DT466/DT360

Ford Diesel Compression Test Adapter

- Use with OTC No. 5021 diesel engine compression gauge.
- Remove glow plug; this adapter is used to connect the No. 5021 gauge to perform a compression test.
- Application: 1994–2003 Ford vans and pickups with 7.3L direct-injected turbocharged (DIT) diesel engine.

No. 6076 – Ford diesel compression test adapter. Wt., 5 oz.

Similar to
Ford 303-D103
(D94T-6600-E)



6076

Ford Diesel Compression Test Adapter

- Use with OTC No. 5021 diesel engine compression gauge.
- Works on 2003-2006 Ford vans and trucks—with 6.0L diesel engines.

6660 – Ford diesel compression test adapter. Wt., 7 oz.

Similar to
Ford 303-757



6660

Ford 5-pin Connector Harness for Glow Plug Testing

- Provides an easy way to check glow plug resistance without having to remove the valve cover of 1994-98 Ford trucks and vans with 7.3L DIT (direct-injected turbocharged) diesel engine.
- Use with any standard digital volt ohmmeter to check glow plug resistance.

No. 6088 – Ford 5-pin connector harness for glow plug testing. Wt., 4 oz.



6088

Ford 9-pin Connector Harness for Glow Plug Testing

- Permits testing glow plug resistance without having to remove the valve cover of 1998-1/2–2003 Ford trucks and vans with 7.3L DIT (direct-injected turbocharged) diesel engines.
- Use with any standard digital volt ohmmeter to check glow plug resistance.

No. 6089 – Ford 9-pin connector harness for glow plug testing. Wt., 8 oz.



6089

Ford Oil Line Disconnect Tool

- Use to disconnect the high-pressure oil rail supply line from the fuel rail when removing fuel injectors.
- Works on the 6.0L diesel engine found in 2003–'07 F-250, F-350, F-450, and F-550 trucks, and Ford Excursions.

No. 6594 – Ford oil line disconnect tool. Wt., 5 oz.

Similar to
Ford 303-755

6594

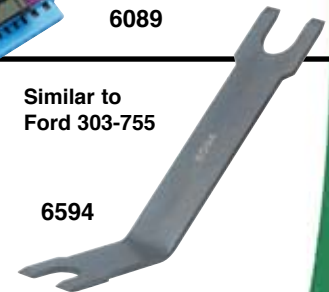

High Pressure Oil Line Disconnect Tool

- Use to disconnect the high pressure oil line from the cylinder head.
- Works on 1998 - 2003 Ford vans and trucks with 7.3L direct-injected, turbo-charged (DIT) diesel engines.

No. 6595 – High pressure oil line disconnect tool. Wt., 3 oz.

Similar to Ford
303-625

6595



Ford Injector Remover/Installer Kit

- Removes and installs injectors without damaging the injector or cylinder head.
- Application: 1994–2003 Ford 3/4- and 1-ton trucks, Super Duty trucks, and vans with 7.3L direct-injected turbocharged (DIT) diesel engine.

No. 6067 – Ford injector remover/installer kit. Wt., 6 oz.

Similar to
Ford 303-491
and 303-492

6067

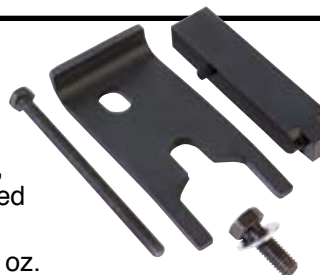

HEAVY-DUTY TOOLS

Diesel Injector & Fuel Tools



6069

Similar to
Miller 8318

Cummins Diesel Fuel Injector Remover Kit

- Kit contains a fuel injector connector tube remover and fuel injector puller. The fuel injector connector tube must be removed before pulling the injector, or both will be damaged.
- Application: 1998-1/2–2002 Dodge pickups and vans with 5.9L 24-valve Cummins diesel turbo engine.

No. 6069 – Cummins diesel fuel injector remover kit. Wt., 8 oz.

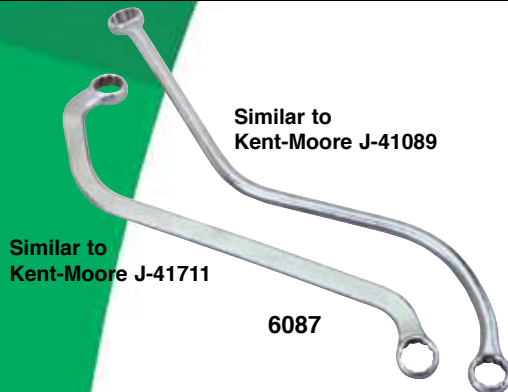

Similar to
Kent-Moore J-41089

Similar to
Kent-Moore J-41711

6087

GM Injection Pump Wrench Set

- Use to loosen or tighten injection pump retaining bolts whenever pump timing adjustment or pump service is required. Services 1996–2000 GM full-size 2- and 4-wheel drive trucks, vans, and Suburbans with 6.5L diesel engine.
- Two specially bent wrenches are needed, due to the location of the throttle, cruise control, T.V. cable bracket, cooling system crossover pipe and bracket, and the thermostat housing.
- Wrenches are 15 mm, 12-point, double box-end type.

No. 6087 – GM injection pump wrench set. Wt., 1 lb.



5060

Detroit Diesel Injector Socket

Because of their location, some injectors are difficult to remove or install. But with this 30 mm socket, you'll be able to attach a 3/8" square-drive tool or 7/8" wrench. The socket fits injectors snugly to provide a good grip and avoid damage.

- Works on 6.2L and 6.5L engines.

No. 5060 – Detroit Diesel injector socket. Wt., 8 oz.



6080

Master Cummins Diesel Fuel Injection Test Kit

- Includes the fittings and gauge needed to check fuel pressure, fuel volume, and fuel restrictions from the delivery pump to the injection pump.

Contents:

No. 518501 – Special quick-disconnect banjo fitting (M14 x 1.5 external).

No. 7915 – Two fuel injection quick-coupler adapters.

No. 7426 – Quick-disconnect banjo fitting (M12 x 1.5 external).

No. 223336 – Gauge assembly.

No. 6082 – Fuel volume test adapter.

No. 6078 – Diesel fuel inlet restriction test adapter.

- Application: 1988–98 Dodge pickups and vans with 5.9L 12-valve, & 1998-1/2–2003 5.9L 24-valve Cummins diesel engines.

No. 6080 – Master Cummins diesel fuel injection test kit. Wt., 5 lbs.

Cummins Diesel Fuel Volume Test Adapter

- Use to perform fuel volume test on fuel transfer pump. Fuel volume is as important as fuel pressure. Pump may pass pressure test, but fail volume test. Fitting is threaded into transfer pump, and No. 6082 is attached to the barbed end. The end of the 2 ft. tubing is placed into a container for fuel to be measured.
- Application: 1994–1998-1/2 Dodge pickups and vans with 5.9L 12-valve Cummins diesel engine.

No. 6082 – Cummins diesel fuel volume test adapter. Wt., 3 oz.



Cummins Diesel Fuel Inlet Restriction Test Adapter

- Adapter is used to perform a vacuum test on the transfer pump; excessive vacuum reading indicates a fuel inlet restriction.
- Application: 1988–95 Dodge trucks and vans with 5.9L 12-valve Cummins diesel engine. Included in OTC set No. 6080.

No. 6078 – Cummins diesel fuel inlet restriction test adapter. Wt., 1 lb., 3 oz.

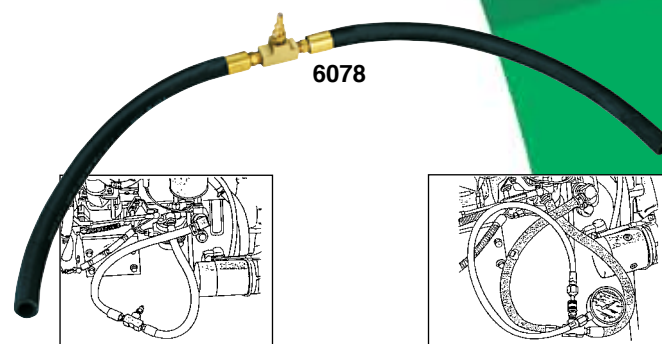

Special Quick-Disconnect Banjo Fitting

- Adapter fitting (M14 x 1.5 male) is used to check fuel pressure from the delivery pump to the injection pump. Use with gauge assembly of OTC set No. 6079.
- Has quick-connect Schrader valve on end of fitting for safety and ease of hook-up to gauge. Included in OTC kit No. 6080.
- Application: 1996–1998-1/2 Dodge pickups and vans with 5.9L 12-valve Cummins engine.

No. 518501 – Special quick-disconnect banjo fitting. Wt., 3 oz.

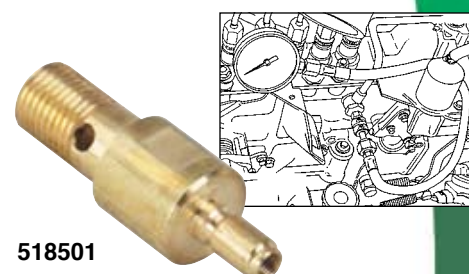

Cummins Engine Barring Tool

Need to manually rotate an engine? This tool makes the job easy. Just insert the tool into the flywheel housing until it engages the ring gear. Then attach a 1/2" square drive ratchet or breaker bar and turn. The tool's load-bearing collar provides friction-free operation while rotating the tool in the housing.

- Works on Cummins B and C series diesel engines and 5.9L diesels used in Dodge pickups.

No. 7471A – Cummins engine barring tool. Wt., 11 oz.



Cummins Engine Turning Tool

This tool makes easy work of manually rotating a Cummins 855 cubic inch engine. It's essential hardware when you're bringing pistons to top dead center to adjust injector timing.

No. 7161 – Cummins engine turning tool. Wt., 4 lbs., 5 oz.

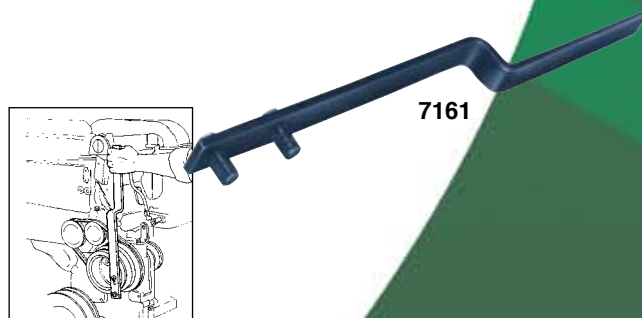

HEAVY-DUTY TOOLS

Pullers, Air Cooler Tester



7119

Similar to
Kent-Moore J-29953-A

Compressor Drive-Gear Coupling Puller

Here's the solution for removing the coupling from the Cummins Compact and Bendix air compressors found on many Cummins 855 cubic inch engines. The split collet design fits over the coupling, and mechanical force does the work.

- Works on compressors with 1-3/4" O.D. shaft.

No. 7119 – Compressor drive-gear coupling puller. Wt., 2 lbs., 7 oz.

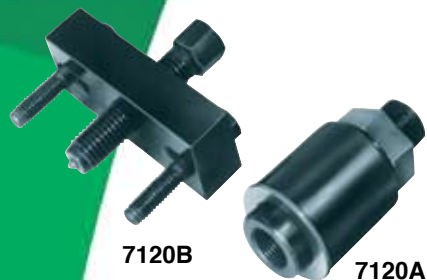

7120B

7120A

Cummins Drive-Pulley Tool Set

This two-piece set is designed to remove and install the drive pulley on Cummins NH and NTC 855 cubic inch engines. The 7120B remover simply bolts into the tapped holes for pulling. The 7120A installer threads onto the pulley accessory drive shaft for easy installation.

No. 7120 – Cummins drive-pulley tool set. Wt., 5 lbs., 5 oz.

No. 7120A – Drive-pulley installer. Wt., 2 lbs., 3 oz.

No. 7120B – Drive-pulley remover. Wt., 3 lbs.



5071

Cummins Water Pump Pulley Tool

This heavy-duty tool is designed to remove or install water pump pulleys on Cummins L10 and M11 engines, 1991 and newer. The installer has a rugged thrust bearing that allows for friction-free pulley installation without damaging pump components.

No. 5071 – Cummins water pump pulley tool. Wt., 2 lbs., 4 oz.

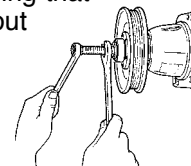

5039

Charged Air Cooler Tester

This is the easy way to find air leaks in the charged air cooler systems used on class 7 & 8 truck engines. The tester features a large 2-1/2", 0-60 PSI pressure gauge, regulator and relief valve, and two safety cables. It also has quick disconnect air fittings that attach to a 3", 3-1/2", or 4" cooler hose.

No. 5039 – Charged air cooler tester. Wt., 7 lbs., 6 oz.

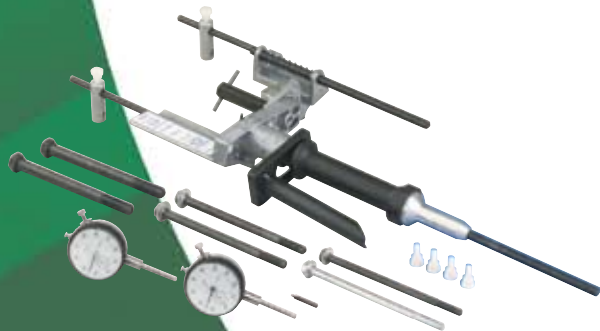

7470

Cummins Diesel Injector Timing Kit

Measures static timing on Cummins J, K, N, NH, V-12, N-14, and L-10 series diesel engines. With this tool you can determine the injector push tube travel in relation to piston travel. Tool is installed with one dial indicator in the injector bore and the other on the injector push tube. Turn the engine over manually to find top dead center. By checking the gauges, you can determine if timing is within factory specifications, then make adjustments to the cam followers.

No. 7470 – Cummins diesel injector timing kit. Wt., 15 lbs.

Truck Clutch Alignment Shafts

These 10-spline clutch alignment shafts are available in the three most popular sizes: 1-1/2", 1-3/4", 2" O.D., and are designed for use on heavy-duty single, two-plate, push/pull, manual, and self-adjust clutches. The shafts are constructed of lightweight fiberglass-reinforced nylon that won't hang up in clutch disc splines. Yet, they're rugged and will easily support the weight of heavy pressure plates.

No. 5070 – Truck clutch alignment shaft. 1-1/2" O.D., 30 mm pilot. Wt., 10 oz.

No. 7072A – Truck clutch alignment shaft. 1-1/2" O.D., 1" pilot, 10 splines, 3.25" long. Similar to Ford 308-D001 (D79T-7550-A). Wt., 10 oz.

No. 7073A – Truck clutch alignment shaft. 1-3/4" O.D., 1-1/4" pilot, spline 3.75" long. Similar to Ford 308-D002 (D79T-7550-B). Wt., 11 oz.

No. 7074A – Truck clutch alignment shaft. 2" O.D., 1-1/4" pilot. 10 splines, 3.6" long. Similar to Ford 308-D003 (D79T-7550-C). Wt., 13 oz.

No. 7480 – Truck clutch alignment shaft. 1-3/4" O.D., 1" pilot. Similar to Ford 308-D010 (D93T-7550-A). Wt., 7 oz.

No. 5029 – Clutch alignment shaft. 2" O.D., 1-1/4" pilot. 10 splines, 7.3" long. Similar to Ford 308-D011 (D93T-7550-B). Wt., 1 lb.

No. 5030 – Clutch alignment shaft. 1-3/4" O.D., 1-1/4" pilot, spline 7.375" long. Similar to Ford 308-D012 (D93T-7550-C). Wt., 13 oz.



Clutch-Adjusting Wrench

This clutch-adjusting wrench will solve the difficult, time-consuming job of internally adjusting heavy-duty Spicer clutches. Using this wrench is much quicker and easier than makeshift methods such as pry bars, which often result in component damage, poor job performance, or extra downtime.

No. 7028 – Clutch-adjusting wrench. Wt., 1 lb., 8 oz.

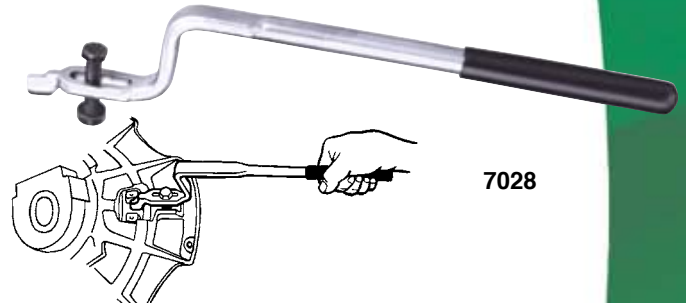

Self-Adjusting Clutch Rotating Tool

This handy tool replaces the self-adjuster mechanism on Spicer self-adjusting clutches, allowing you to manually adjust them with a wrench or socket.

- 3/4" hex drive.

No. 5044 – Self-adjusting clutch rotating tool. Wt., 7 oz.

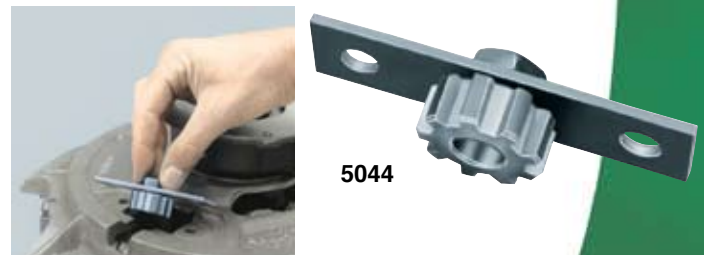

Truck Clutch Adjustment Set

The gauges in this set enable you to check the adjustment of pull-type, heavy-duty clutches, ensuring their correct operation. One gauge checks the amount of free play between the yoke and the bearing's wear pad. The other gauge lets you determine the amount of travel between the release bearing and transmission bearing cap.

No. 5035 – Truck clutch adjustment set. Wt., 1 lb., 8 oz.

No. 5034 – Clutch pedal free play gauge. Wt., 1 lb., 4 oz.

No. 5033 – Release bearing travel gauge. Wt., 4 oz.

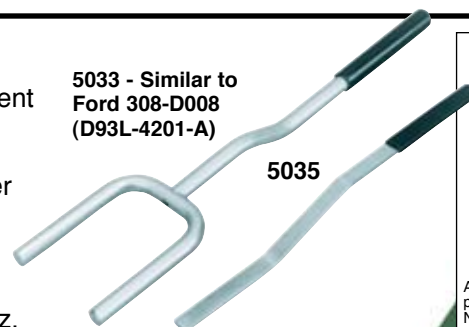

5033 - Similar to Ford 308-D008 (D93L-4201-A)

5035

5034 - Similar to Ford 308-D009 (D93L-7025-A)

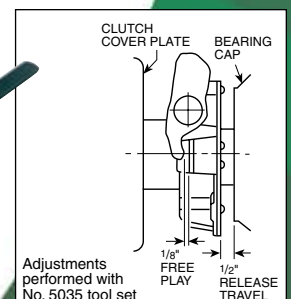

HEAVY-DUTY TOOLS

Clutch & Flywheel Tools



Clutch Service Set

Here's an ideal companion set to the No. 5015 clutch handler. Designed for Spicer heavy-duty clutches, the nine tools in this set help with a variety of jobs, from clutch installation and removal to flywheel drive-pin installation to clutch adjustment.

- Includes handy plastic carrying case.

No. 5043 – Clutch service set.
Wt., 15 lbs., 13 oz.

OTC No.	Description
5044*	Self-adjust clutch rotating tool. Rotates adjusting ring.
5045*	Flywheel drive pin installing tool. Aligns and installs drive pins in 14" heavy-duty truck pot-type flywheels.
5046*	Clutch release tool. Removes shipping blocks from between clutch housing and release bearing.
7028*	Adjusting wrench. For internal adjustment of multiple lever and angle-spring clutches.
7073A*	Clutch alignment tool. 1-3/4" O.D. Provides perfect fit to spline of clutch disc.
7074A*	Clutch alignment tool. 2" O.D. Provides perfect fit to spline of clutch disc.
213013	Pair of 3/8" flywheel to clutch guide pins.
213014	Pair of 7/16" flywheel to clutch guide pins.
213015	Hex key wrench. Removes/installs flywheel drive pin set screws.

* Tool is available separately.



Clutch Release Tool

- Permits removal of the shipping blocks from new clutch assemblies.

No. 5046 – Clutch release tool. Wt., 3 lbs., 10 oz.

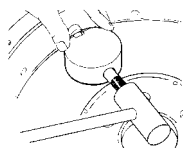

Drive Pin Installing Tool

- Enables precise alignment and installation of the spacer plate drive pins on a pot-type 14" flywheel.
- Ensures free action of clutch assembly.

No. 5045 – Drive pin installing tool. Wt., 3 lbs.

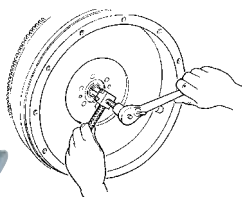

Pilot Bearing Pullers

These tools make quick work of pulling stubborn, rusted pilot bearings. No. 5048 fits 1-1/4" I.D. bearings, and No. 5049 fits 1" I.D. bearings. The puller's forcing screw expands the jaws inside the bearing and simultaneously pushes against the crankshaft.

No. 5048 – Pilot bearing puller for 1-1/4" I.D.
Wt., 1 lb., 3 oz.

No. 5049 – Pilot bearing puller for 1" I.D.
Wt., 1 lb., 3 oz.

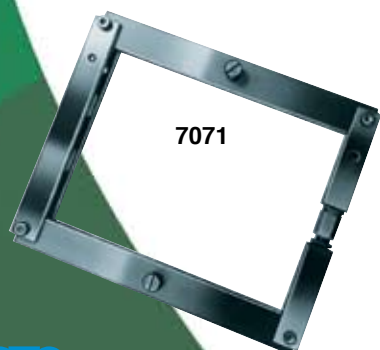

Differential Housing Spreader

Removing and installing differential ring gear assemblies is typically a difficult, time-consuming chore – that is, unless you're using this differential housing spreader. This device uses mechanical screw power to spread the housing, allowing easy removal of the differential assembly while eliminating damage often caused by makeshift methods.

- Works on Dana axle models 30 through 70.

No. 7071 – Differential housing spreader.
Wt., 34 lbs.

U-Joint Puller

This service tool easily removes stubborn, corroded bearings without damaging U-joint components, even in limited space. The tool applies up to 7 tons of force to separate yoke assemblies and remove bearings. Far superior to sledgehammer methods.

- Works on Meritor 16N, 17N, 18N, and 1710 series U-joints and Spicer 1600/1610 to 1880 series U-joints.
- Includes plastic storage box, No. 1036 2-jaw puller, and instructions.

No. 7057 – U-joint puller. Wt., 16 lbs., 3 oz.

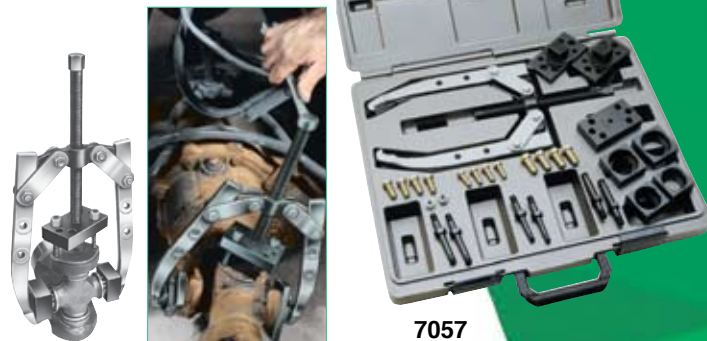

Heavy-Duty U-Joint Puller

The ideal tool for disassembling drivelines.

- May be used with up to a one-inch impact wrench.
- Quickly and easily removes sealed U-joint cups without the need for hammering or heat.
- Will not damage the driveshaft, yoke, bearing cups, or joints.
- Fits practically all Class 7 and 8 trucks, including:
Spicer driveline 1610, 1710, 1760, 1810, 1880
Spicer SPL 140, 170, and 250 "Life Series"
Meritor (Rockwell) 16N, 17N, 18N, 1710
Meritor RPL 20 and 25 "Permalube" Series

No. 5190 – Heavy-duty universal joint puller. Wt., 11.4 lbs.

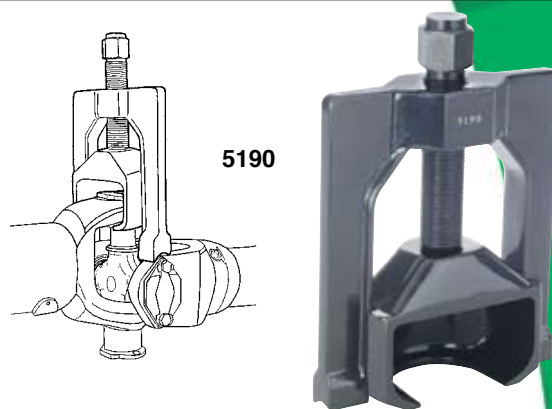

Heavy-Duty Bearing Cup Installer

Quickly and easily installs bearing cups on Dana/Spicer SPL "Life Series" quick-disconnect universal joints.

- Three individual adapters press bearings to the manufacturer's recommended depths.
- Adapters fit Spicer SPL 140, 170, and 250 series drivelines.

No. 5191 – Heavy-duty bearing cup installer. Wt., 18 lbs.



Heavy-Duty Bearing Cup Installer

Quickly and easily installs bearing cups on bolt-retained universal joints. Fits series 1610 to 1880 and nearly all other heavy-duty truck and machine type u-joints with bolt-retained bearing cups.

- Automatically aligns bearing cups during installation.
- Eliminates the possibility of damage to the needle bearing.

No. 5192 – Heavy-duty bearing cup installer. Wt., 1 lb., 11 oz.



U-Joint Tool

Designed for a 1/2" impact wrench, this U-joint tool removes even the most stubborn U-joints with ease. It's compact and easily set up, making it ideal for service calls. And it can be used at different angles and in tight places, eliminating those damaging makeshift methods. The puller's legs have holes for bolt storage.

- Bolts included: 5/16"-24 x 1-1/2", 3/8"-24 x 1-1/2", 7/16"-20 x 1-1/2", M8-1.25 mm x 35 mm.
- Works on most Dana Spicer and Meritor U-joints – **except** Spicer's Life series model SPL250X.

No. 7490 – U-joint tool. Wt., 10 lbs., 7 oz.



HEAVY-DUTY TOOLS

Truck Wheel Bearing Locknut Sockets

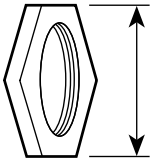

Measure from flat to flat to determine size of locknut, then consult chart to select a socket. **Warranty is void if tool is subjected to impact wrench use.**

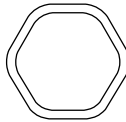

* Fits special "rounded" hex nut found on Dana axles of some Ford trucks.

* Depth of locknut sockets is 5".

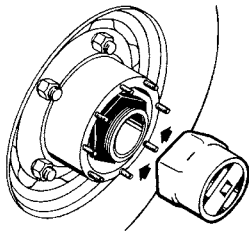

Wheel bearing locknuts are easy to remove or install with these specially designed sockets. They're made of high-strength steel and resist rounding out.

NOTE: Sockets are designed for use with 3/4" square-drive manual tools only. Impact tool use voids sockets' warranty.

1902 – Similar to Ford No. 205-039 (T70T-4252-B)

1904 – Similar to Ford No. 205-040 (T70T-4252-D)

1905 – Similar to Ford No. 205-041 (T70T-4252-E)

1910 – Similar to Ford No. 205-042 (T70T-4252-K)

1928 – Similar to Ford No. 205-043 (T70T-4252-W)

Measure from flat to flat to determine size of locknut, then consult chart to find the correct socket.

Socket No.	Opening Size	Socket No.	Opening Size
1901	2-3/32" (6 pt.)	1924	3-3/8" (8 pt.)
1920	2-1/4" (6 pt.)	1910	3-1/2" (6 pt.)
1902	2-3/8" (6 pt.)	1911	3-1/2" (8 pt.)
1936*	2-3/8" (6 pt.)	1925	3-3/4" (8 pt.)
1903	2-3/8" (8 pt.)	1926	3-3/4" (6 pt.)
1921	2-1/2" (6 pt.)	1927	3-13/16" (8 pt.)
1904	2-9/16" (6 pt.)	1912	3-7/8" (6 pt.)
1905	2-9/16" (8 pt.)	1913	3-7/8" (8 pt.)
1928*	2-9/16" (6 pt.)	1914	4" (6 pt.)
1922	2-5/8" (6 pt.)	1915	4-1/8" (6 pt.)
1923	2-3/4" (6 pt.)	1940	4-1/8" (8 pt.)
1937	2-3/4" (8 pt.)	1916	4-3/8" (6 pt.)
1932	2-7/8" (6 pt.)	1917	4-3/8" (8 pt.)
1933	2-7/8" (8 pt.)	1938	4-1/2" (8 pt.)
1906	3" (6 pt.)	1941	4-13/16" (8 pt.)
1907	3" (8 pt.)	1918	4-7/8" (6 pt.)
1934	3-1/8" (6 pt.)	1919	4-7/8" (8 pt.)
1935	3-1/8" (8 pt.)	1939	5-1/4" (6 pt.)
1908	3-1/4" (6 pt.)	7795	2-1/2" (6 pt.)
1909	3-1/4" (8 pt.)	7796	2-3/4" (6 pt.)

Metric Truck Wheel Bearing Locknut Sockets

Socket No.	Opening Size	Socket No.	Opening Size
1950M	54 mm (6 pt.)	1957M	90 mm (8 pt.)
1951M	55 mm (6 pt.)	1958M	94 mm (8 pt.)
1952M	60 mm (6 pt.)	1962M	100 mm (8 pt.)
1953M	70 mm (6 pt.)	1959M	106 mm (8 pt.)
1954M	71 mm (6 pt.)	1960M	110 mm (8 pt.)
1955M	80 mm (6 pt.)	1961M	120 mm (8 pt.)
1956M	82 mm (8 pt.)		



9850

Truck Wheel Bearing Locknut Sockets (6-pt.)

No. 9850 – 21 wheel bearing locknut sockets with tool board.

Wt., 54 lbs., 7 oz.

No. 62908 – Display board only. Wt., 5 lbs., 7 oz.

No.	Qty.	Description
1901	1	Locknut socket (2-3/32")
1902	1	Locknut socket (2-3/8")
1904	1	Locknut socket (2-9/16")
1906	1	Locknut socket (3")
1908	1	Locknut socket (3-1/4")
1910	1	Locknut socket (3-1/2")
1912	1	Locknut socket (3-7/8")
1914	1	Locknut socket (4")
1915	1	Locknut socket (4-1/8")
1916	1	Locknut socket (4-3/8")
1918	1	Locknut socket (4-7/8")
1920	1	Locknut socket (2-1/4")
1921	1	Locknut socket (2-1/2")
1922	1	Locknut socket (2-5/8")
1923	1	Locknut socket (2-3/4")
1926	1	Locknut socket (3-3/4")
1928	1	Lknt. skt. (2-9/16" rounded)
1932	1	Locknut socket (2-7/8")
1934	1	Locknut socket (3-1/8")
1936	1	Lknt. skt. (2-3/8" rounded)
1939	1	Locknut socket (5-1/4")

Wheel Bearing Locknut Sockets (8 pt.)

No.	Qty.	Description	No.	Qty.	Description	No.	Qty.	Description
1903	1	Locknut socket (2-3/8")	1917	1	Locknut socket (4-3/8")	1930	1	Locknut socket (2-7/8")
1905	1	Locknut socket (2-9/16")	1919	1	Locknut socket (4-7/8")	1931	1	Locknut socket (3-5/8")
1907	1	Locknut socket (3")	1924	1	Locknut socket (3-3/8")	1933	1	Locknut socket (2-7/8")
1909	1	Locknut socket (3-1/4")	1925	1	Locknut socket (3-3/4")	1935	1	Locknut socket (3-1/8")
1911	1	Locknut socket (3-1/2")	1927	1	Locknut socket (3-13/16")	1937	1	Locknut socket (2-3/4")
1913	1	Locknut socket (3-7/8")	1929	1	Locknut socket (2-5/8")	1938	1	Locknut socket (4-1/2")

No. 9851 – 18 wheel bearing locknut sockets (8 pt.) with tool board. Wt., 53 lbs., 14 oz.

No. 62909 – Display board only. Wt., 6 lbs., 11 oz.

Wheel Bearing Locknut Sockets

- A selection of popular sizes in 6- or 8-point.

No. 9852 – 12 wheel bearing locknut sockets and tool board. Wt., 34 lbs., 4 oz.

No. 62910 – Display board only. Wt., 5 lbs., 3 oz.

No.	Qty.	Description	No.	Qty.	Description
1904	1	Locknut skt. (2-9/16" hex)	1921	1	Locknut skt. (2-1/2" hex)
1908	1	Locknut skt. (3-1/4" hex)	1922	1	Locknut skt. (2-5/8" hex)
1909	1	Locknut skt. (3-1/4" 8 pt.)	1923	1	Locknut skt. (2-3/4" hex)
1910	1	Locknut skt. (3-1/2" hex)	1928	1	Locknut socket (2-9/16" hex rounded)
1913	1	Locknut skt. (3-7/8" 8 pt.)	1932	1	Locknut skt. (2-7/8" hex)
1914	1	Locknut socket (4" hex)			
1915	1	Locknut skt. (4-1/8" hex)			



9851



9852

Tubular Spanner Wrenches

- Six-lug, spanner-type wrenches remove and install rear wheel bearing locknuts. They're built for use with a 3/4" square-drive ratchet or breaker bar.

No. 1929 – Wrench for servicing Chevrolet and GMC 5,200 and 7,200 lb. axles. Socket O.D. is 2-5/8". Wt., 1 lb., 11 oz.

No. 1930 – Wrench for servicing Chevrolet and GMC 11,000 to 13,500 lb. axles. Socket O.D. is 2-7/8". Wt., 2 lbs., 5 oz.

No. 1931 – Wrench for servicing Chevrolet and GMC 15,000 lb. axles; 17,000 lb. 2-spd. axles; 15,000 lb. trailing axles. Socket O.D. is 3-5/8". Wt., 3 lbs., 14 oz.



Budd Wheel Sockets

- Metric sizes for Isuzu, Hino, Mitsubishi Fuso, and import trucks; fit front and rear axle wheels.
- 1-1/2" hex Budd wheel socket for American-made trucks with dual rear wheels.

These sockets work on the import truck Budd wheels. Their extra deep design lets you remove both nut and stud with just the one socket. Usable with a 1" square drive impact wrench.

No. 1944 – Consists of 1945A, 1946A, 1947A, 1948A, and 1949A, in a blow molded organizer case.

No. 1945A – 35 mm hex socket with 17 mm sq. Wt., 2 lbs.

No. 1946A – 38 mm hex socket with 20 mm sq. Wt., 2 lbs., 8 oz.

No. 1947A – 41 mm hex socket with 21 mm sq. Wt., 2 lbs., 14 oz.

No. 1948A – 33 mm hex Budd wheel socket. For Mack Midliners, White Volvo, and other import trucks w/dual rear wheels. Wt., 1 lb., 8 oz.

No. 1949A – 1-1/2" hex Budd with 13/16" square wheel socket. For American-made trucks with dual rear wheels. Wt., 2 lbs., 8 oz.



No. 1944

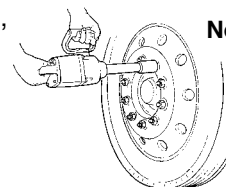

HEAVY-DUTY TOOLS

Locknut, Lug, Hubcap Tools



9814

Truck Pinion Sockets

We've designed and built these sockets to have the correct clearance for yoke and locknut assemblies on a variety of truck transmissions and differentials. The sockets have 3" of usable depth and are 4" long. Using the right tools saves time and effort, eliminating the need to destroy standard sockets by grinding them down to fit tight pinion clearances.

No. 9814 – Tool board and six sockets, 1975 thru 1980 listed above. Wt., 22 lbs., 6 oz.

No. 1981* – Socket only, not included in set. Wt., 3 lbs., 10 oz.

No. 62911 – Tool board only. Wt. 2 lbs.

Socket No.	Opening Size
1975	2" (6 pt.)
1976	2-1/8" (6 pt.)
1977	2-1/4" (6 pt.)
1978	2-3/8" (6 pt.)
1979	2-5/8" (6 pt.)
1980	2-3/4" (6 pt.)
1981*	2-1/2" (6 pt.)

NOTE: Use sockets with 3/4" square-drive, manually powered handles only. Warranty void if tool is subjected to impact wrench use.



9901

"Major Persuader" Pry Bar Merchandiser

- Displays five of OTC's biggest pry bars on a bright, eye-level merchandiser.
- Display measures 16"w x 18"d x 64"h.
- Includes 5 pry bars: two 30", two 46", and one 54" in length.

No. 9901 – Heavy-duty pry bar merchandiser display. Wt., 40 lbs.

Bar No.	Qty.	Desc.
7168	2	30" jimmy bar
7420	2	46" jimmy bar
7421	1	54" jimmy bar



5047

Lug Nut Cap Remover

Chrome-plated lug nut caps found on many heavy-duty trucks and trailers can be tough to remove, and they're easily damaged if you pry them off or use an ordinary cap remover. This tool avoids those problems. It is ruggedly built and features specially coated jaws that won't slip off the caps, no matter how much squeezing force you apply.

- Features cushioned handles.

No. 5047 – Lug nut cap remover. Wt., 13 oz.



5059

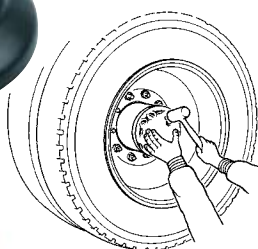

Hubcap Installer

Truckers like chrome, and many of them accent their truck's drive axle with chrome hubcaps designed to snugly fit around the axle-shaft bolts. Unfortunately for service shops, these hubcaps are often tricky to install without causing damage. That's where our hubcap installer comes in handy. Constructed of high-density polyethylene, this tool guides the cap into place over the axle nuts, protecting it from unwanted and costly dents.

No. 5059 – Hubcap installer. Wt., 1 lb.

Heavy-Duty Power Steering Pump Analyzer

- There is only one way to troubleshoot problem components in a heavy-duty power steering system: a flow and pressure reading meter. OTC's new No. 5079 measures both: 1 to 10 gallons oil flow and up to 3,000 psi of pressure.
- When connected in line, this universal analyzer will isolate the failed components in just minutes. There is no wasted time as in trial and error methods.
- The set is complete with high pressure hoses, 9/16"-18 standard fittings, and quick disconnect couplers to handle Eaton/Vickers, TRW, Ross, and Shepard power steering systems.

No. 5079 – Heavy-duty power steering pump analyzer. Wt., 6 lbs.

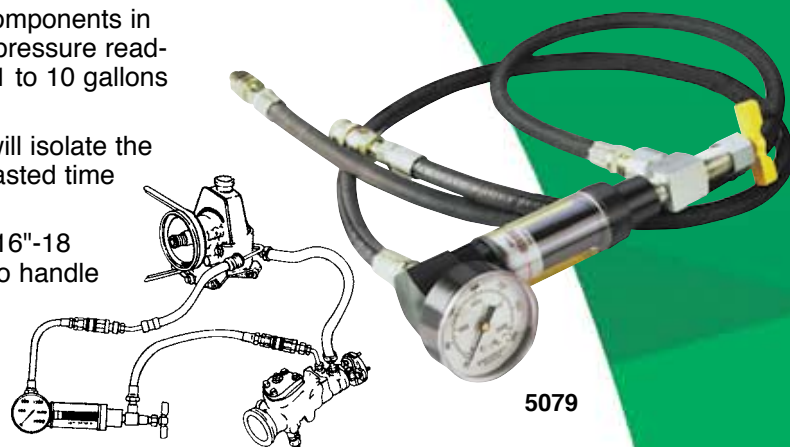

Kingpin & Brake Anchor Pin Pusher

With this pin remover, hydraulic force and precision tooling replace torch-and-hammer methods for getting the job done quickly and easily. Five special collars and two pins allow this unit to work on both straight and tapered kingpins and accommodates sizes from 7/8" to 2" in diameter and up to 11-1/4" long. The tool delivers 30 tons of hydraulic force to push out even the most corroded kingpins. A job that could consume the better part of a day is done in minutes. The anchor pin can be removed quickly by using the special adapter installed in the pusher's base block and the unit positioned over the brake's spider.

- Works on many models of trucks and buses.
- 27-1/2" high x 8-1/2" wide. • 30-ton capacity.
- Set includes No. 4002 hydraulic hand pump, No. 9767 hose, No. 9798 hose-half coupler, No. 4121 Power Twin 30-ton ram, and No. 29424 anchor pin adapter.

No. 4240 – Complete kingpin and anchor pin pusher set with hydraulics. Wt., 114 lbs.

No. 4241 – King- and anchor-pin pusher with anchor pin adapter without hydraulics. Wt., 59 lbs., 3 oz.

No. 29424 – Anchor pin adapter only. Wt., 1 lb., 12 oz.



Mack Kingpin Socket

Here is a socket that makes life a little easier for anyone who works on Mack trucks. Designed for 1/2" square drive ratchet or breaker bar, the socket fits the slotted adjusting screw in tapered kingpins used on most Mack front axles (12,000 to 20,000 lbs.).

No. 5053 – Mack kingpin socket. Wt., 13 oz.

Socket O.D. 1.8"



Truck Tie Rod Socket

Designed to withstand the force of a 3/4" drive impact wrench, this rugged socket makes truck tie-rod end removal quick and simple.

- Works on inner and outer tie rod ends on 12,000 to 16,000 lb. truck axles.

No. 5068 – Truck tie rod socket. Wt., 3 lbs., 4 oz.

Socket I.D. 2-3/4"



HEAVY-DUTY TOOLS

Steering, Brake, and Suspension Service



6065

Socket I.D. 2-1/8"

Tie Rod Socket for Medium-Duty Trucks

- Services GM-, Ford-, and Chrysler-built 1-ton 2WD and 4WD trucks.
- Also works on medium-duty Class 2 through Class 6 trucks.
- Use with a 1/2" drive impact wrench to easily remove the tie rod ends from the tie rod.

No. 6065 – Tie rod socket for medium-duty trucks.
Wt., 1 lb., 13 oz.



1767

Hendrickson Primaax Quick Alignment Socket

- Hendrickson – Approved tool.
- Used to adjust axle alignment on the Primaax air suspension.
- Works on Primaax models 230, 460, and 690 rear suspensions.

No. 1767 – Hendrickson Primaax quick alignment socket.
Wt., 3 lbs., 8 oz.

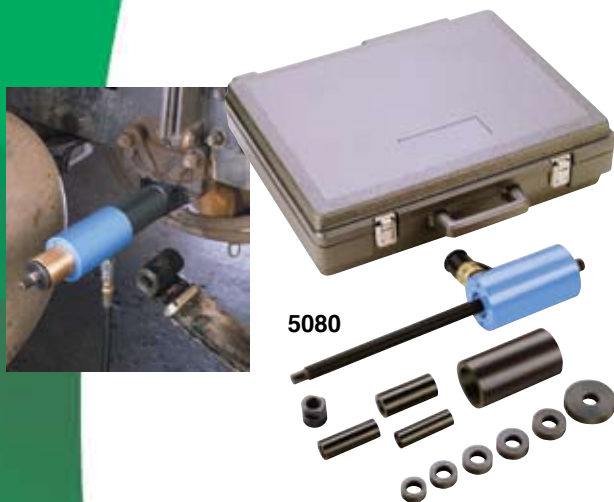

5080

Truck Front Leaf Spring, Pin, and Bushing Service Set

- Delivers 10 tons of hydraulic force to remove and install truck front spring eye bushing assemblies quickly and easily.
- Services bushings with diameters from 1-1/4" through 1-7/8", and pin diameters from 7/8" through 1-1/8". Handles all popular OE and aftermarket components, including Horton pin and bushing assemblies.
- Service bushing assemblies, in many cases, without removing leaf spring hangers and spring assemblies from the vehicle.
- All accessories are included except the hydraulic hand pump, which must be purchased separately.

No. 5080 – Truck front leaf spring, pin, & bushing service set.
Wt., 20 lbs. 8 oz.



5085



Hub Oil Seal Puller

- Eliminates bearing and hub damage that can occur when a punch and hammer is used to remove the seal.
- Extra long 28" handle provides leverage, unique pulling head design quickly and easily removes the seal in one piece.
- Built from the highest quality heat-treated steel.
- Removes hub seals on trailer and truck axles, including truck steering axles.

No. 5085 – Hub oil seal puller.
Wt., 6 lbs., 12 oz.

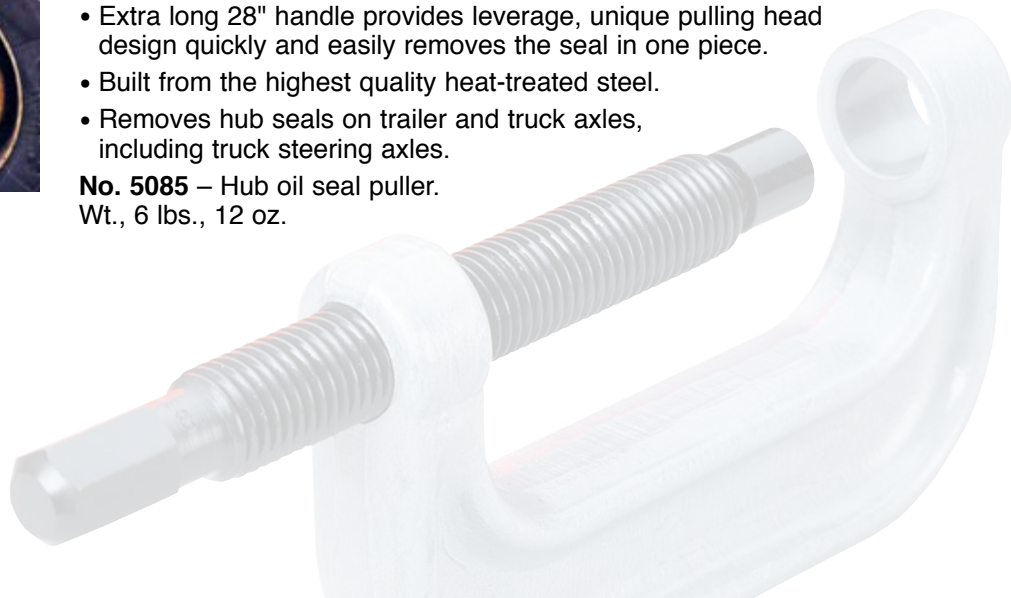

Universal Bearing Cup Installer

This handy, adjustable tool is designed to install wheel-bearing cups in a wide range of heavy-duty axles. Simply adjust and lock the jaws to the cup I.D., slip on the new cup, set it in the bore, and drive it in with a hammer. The tool helps eliminate the damage caused by makeshift methods.

- Works on axles from 11,000 to 50,000 lb. capacity.
- Adjusts to fit 3-5/8" to 6-1/2" O.D. bearing cups, which adds up to as many as 30 individual drivers.

No. 7180 – Universal bearing cup installer. Wt., 11 lbs.

No. 52038 – Replacement jaw.

No. 207561 – Replacement retaining spring.

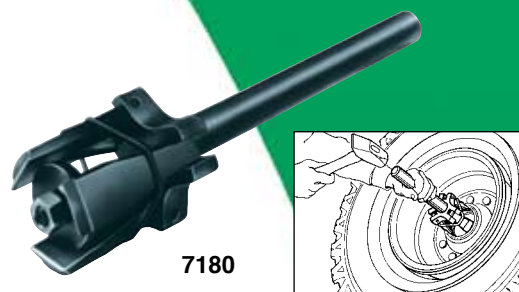

Slack Adjuster Pullers

These pullers will yank even the most corroded slack adjuster off the S-cam — and do so in just a fraction of the time needed with “heat and beat” methods. Plus, they won’t damage components. Both pullers have a rugged forcing screw and cast steel body. Puller No. 5055 fits many manual types, and the No. 5056 works on Rockwell, Haldex, Gunite, and Bendix automatic adjusters.

No. 5055 – Manual slack adjuster puller. Wt., 5 lbs.

No. 5056 – Automatic slack adjuster puller. Wt., 6 lbs.



Air Brake Service Kit

This kit has the tools needed to remove slack adjusters and push-rod clevis pins used in the S-cam brake systems of class 7 and 8 vehicles.

- Works on manual or automatic slack adjusters.
- Includes Nos. 5055 and 5056 slack adjuster pullers, 5057 brake clevis pin press, and a plastic storage case.

No. 5054 – Air brake service kit. Wt., 14 lbs., 10 oz.



Clevis Pin Press

Removing corroded clevis pins from a brake air-chamber pushrod can be a maddening and time-consuming task — unless you’re using our clevis pin press. This handy screw-operated tool applies the force just where it’s needed. The pin is easily removed from its hole without damaging nearby components.

No. 5057 – Clevis pin press. Wt., 1 lb., 13 oz.



Slack Check

This tool enables you to quickly check the brake adjustment on class 7 and 8 trucks and trailers having S-cam brakes. It features a sturdy, four-position handle to provide the leverage you need at the proper angle.

- Works on manual or automatic slack adjusters.

No. 5052 – Slack check. Wt., 1 lb., 3 oz.

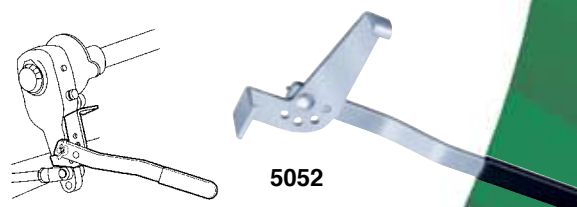

Heavy-Duty Anchor Pin Press

With this rugged C-frame press, you can easily remove stubborn and rusted brake anchor pins from spyderys on heavy-duty vehicles. Mechanical screw power does the job quickly and efficiently.

- Works on brake pins up to 1-1/4" in diameter.

No. 7248 – Heavy-duty anchor pin press. Wt., 9 lbs., 6 oz.

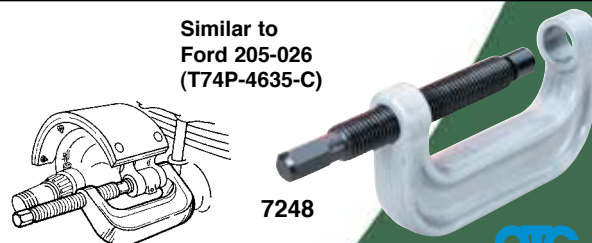

Similar to
Ford 205-026
(T74P-4635-C)

HEAVY-DUTY TOOLS

Brake Service

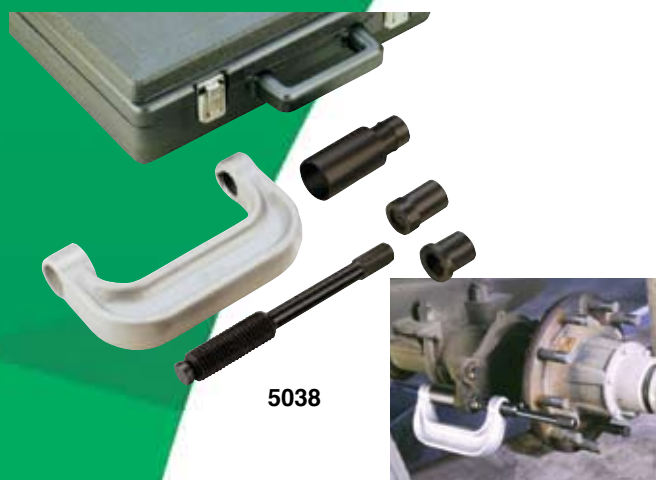

Brake Anchor Pin and Bushing Service Set

With the No. 5038, there's no need to remove the bearing hub assembly just to replace the pins and bushings on 16-1/2" S-cam trailer and tractor "Q" brake systems. Much less complicated and time consuming!

- Special tooling and our C-frame press get you past the hub assembly, so you can do the job quickly and professionally without damaging other parts.
- Includes everything needed for removal and replacement.
- Tooling is available separately for the tech who already owns the 7248 C-frame press.

No. 5038 – Brake anchor pin and bushing service set includes C-frame press and tooling in a plastic storage case. Wt., 13 lbs., 9 oz.



Axle-Stud Cone Pliers

Now you can easily remove the tapered cone from studs used on the rear axles of medium and heavy-duty trucks. This specially designed tool gives you the leverage needed to expand the cone and remove it from the stud for axle removal.

No. 7077 – Axle stud cone pliers. Wt., 13 oz.

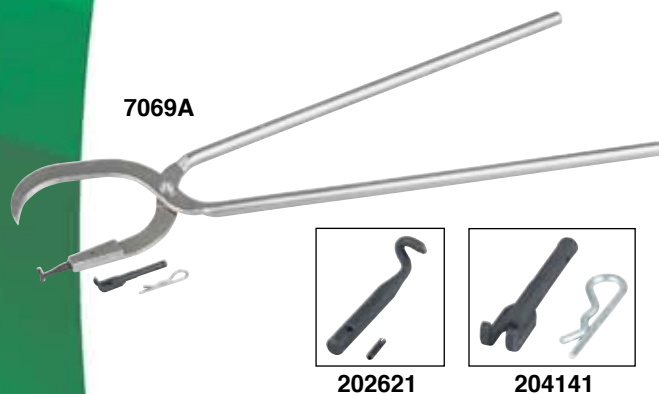

Heavy-Duty Brake Spring Pliers

Save time and effort when removing and installing return springs on the brake shoes of heavy-duty vehicles. This specially designed pliers works for hydraulic wedge-type and "S" cam air brakes. Its 26-1/4" length gives you the leverage to do the job more easily, and the huge jaw opening accommodates even the widest brake shoes.

No. 7069A – Heavy-duty brake spring pliers with "S" cam and wedge-type replaceable tips. Wt., 4 lbs., 8 oz.

No. 202621 – Wedge-type replacement tip. Wt., 2 oz.

No. 204141 – "S" cam replacement tip. Wt., 2 oz.



Truck Brake Spring Pliers

• Designed to remove and install the brake shoe return springs on medium-duty and heavy-duty drum brakes.

No. 4592 – Truck Brake Spring Pliers. Wt., 2 lbs., 13 oz.

No. 4592-1 – Replacement tip.

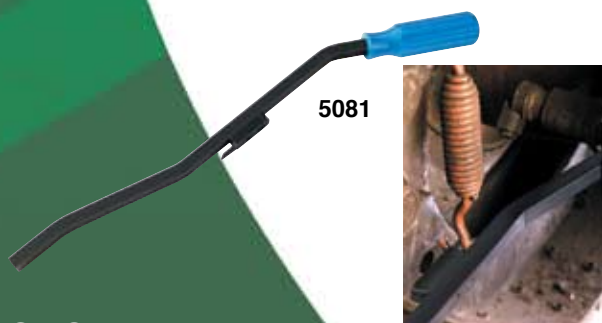

S-Cam Air Brake Spring Tool

• Eliminate makeshift, unsafe methods of unhooking and reconnecting retaining springs when replacing brake shoes on heavy-duty tractors and trailers.

• Simply hook the retaining spring loop and press down. Lever action against the axle makes the job a snap!

No. 5081 – S cam air brake spring tool. Wt., 1 lb., 6-oz.

No. 314548 – Replacement hook kit. Wt., .5 lb.



Hydraulic Brake Spring Tool

Here's a tool to remove and install the return springs in Lucas Girling hydraulic brake systems. The tool's machined tip cradles the return spring securely, and its sliding fulcrum gives you all the leverage needed to do the job. A knurled handle helps prevent slipping.

- Works on 1984 to current Ford F600, F700, and F800 series having Lucas Girling hydraulic brakes.

No. 7462 – Hydraulic brake spring tool.
Wt., 10 oz.



Lucas Rear Brake Adjusting Tool

If you're working on a lot of medium-duty hydraulic brake systems, you need our adjusting tool. It enables you to easily adjust Lucas Girling hydraulic brake systems (popular in Ford F700, F800, and F900 series). The tool's offset design and extra handle length get the job done quickly.

No. 5072 – Lucas rear brake adjusting tool.
Wt., 1 lb., 2 oz.

Similar to Ford
206-D005 (D90T-2588-A)

5072



Truck Transmission Bearing Service Set

The set is designed to help you remove input shaft bearings and countershaft bearings, in both the main and auxiliary boxes of heavy-duty Fuller transmissions. It will also remove end yokes from 1600/1610-1810 series transmissions. The puller delivers 10 tons of mechanical power— essential force for working on big gearboxes.

- Works on Fuller twin-countershaft transmissions: 125, 600, 660, 900, 9500, 1100, 12500, 12600, 13000, 14600, 15600, and 8600 series, 910-913, 915, and 9513.

No. 7070A – Truck transmission bearing service set.
Wt., 14 lbs., 3 oz.

No. 7075 – Transmission output shaft end yoke remover only. Wt., 4 lbs., 3 oz.

No. 7207 – Collet only. Wt., 4 lbs., 13 oz.



7075

Transmission Timing Block Sets

These sets enable one-man installation of front and rear countershaft bearings on Fuller twin-countershaft transmissions. The set positions the upper countershaft, yet lets you slide it aside to insert the main shaft. When the main shaft is in place and timing marks line up, turn the tool vertically to engage and position the countershaft to main shaft.

No. 7108 – Timing block set for Fuller RTO 610/613 transmissions. Wt., 1 lb., 2 oz.

No. 7109 – Timing block set for Fuller RT and RTO 910, 915, 9513, 12509, 12510, 12513, and 12515 transmissions. Wt., 1 lb., 12 oz.

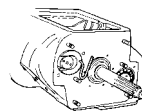

Positioned for main shaft timing.

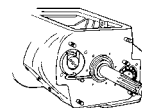

Positioned for bearing installation.



HEAVY-DUTY TOOLS

Transmission Service Tools



Bearing Puller Set

This puller set, designed for use with our No. 7070A transmission service set (sold separately), is designed to remove front countershaft and input shaft bearings on Fuller RT, RTO 610/613 twin countershaft transmissions.

No. 205776 – Bearing puller set. Wt., 2 lbs., 10 oz.

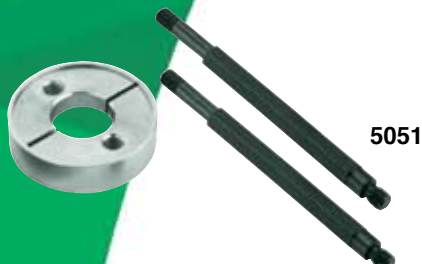

Bearing Puller Set

When teamed with our No. 7070A puller, this puller set will remove front and rear countershaft bearings from the main case of Eaton® Fuller® 2 Series Roadranger® transmissions.

- Includes pulling collet, sleeve, and a pair of puller legs.

No. 5051 – Bearing puller set. Wt., 3 lbs., 12 oz.



Timing Tool

- Designed to support the main-case upper countershaft during transmission assembly and timing.
- Works on Eaton® Fuller® 2 Series Roadranger® transmissions.

No. 5063 – Timing tool. Wt., 2 lbs., 5 oz.



Countershaft Pushing Tool

Replacing rear countershaft bearing snap rings in Eaton Fuller transmissions? With this tool, you can easily move the countershaft rearward to expose the snap ring.

- Works on Eaton® Fuller® Roadranger® transmissions (series 2, 5, 6, and 7).

No. 5064 – Countershaft pushing tool. Wt., 4 lbs., 11 oz.



Countershaft Bearing Driver

- Eases the task of installing a main-case countershaft bearing.
- Works on Eaton® Fuller® 2 Series Roadranger® transmissions.

No. 5065 – Countershaft bearing driver. Wt., 3 lbs., 14 oz.



Bearing Driver

This tool is designed to install the bearing on 2" diameter input shafts used in Eaton® Fuller® Roadranger® transmissions.

No. 5066 – Bearing driver. Wt., 5 lbs., 6 oz.

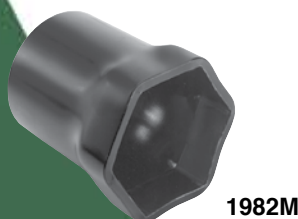

70 mm Hex Socket

Attach this heavy-duty socket to your 3/4" drive ratchet or breaker bar, and you'll be able to easily remove the end-yoke locknut on Eaton® Fuller® 2 Series Roadranger® transmissions.

No. 1982M – 70 mm hex socket. Wt., 3 lbs., 13 oz.

Auxiliary Countershaft Shim Tool

When you're working on Eaton® Fuller® 2 Series Roadranger® transmissions, this tool holds the auxiliary countershaft in place while you set the bearing end play.

- Includes a support strap for .100 and .125 shim settings, and metric and standard mounting bolts.

No. 5062 – Auxiliary countershaft shim tool.
Wt., 3 lbs., 13 oz.

5062



Cummins® Injector Puller

This helpful puller will handle a variety of injectors found in Cummins engines: mechanical L-10, PDT, and PTD top-stop 855NH. Its two-jaw design firmly grips the injector while it is being removed by the slide hammer.

- Includes storage case and special adapter for pulling STC injectors.

No. 5042 – Cummins injector puller.
Wt., 6 lbs.

5042



Cummins® Injector Remover/ Installer

This is our best tool for removing or installing fuel injectors on Cummins L10 and N14 Celect electronically controlled engines. The large slide hammer and pin-type pulling adapter easily—and safely—handle injector jobs.

- Includes storage case.
- Two installing adapters help prevent damage to an injector's electronic solenoid.

No. 5040 – Cummins injector remover/installer.
Wt., 7 lbs., 1 oz.

5040

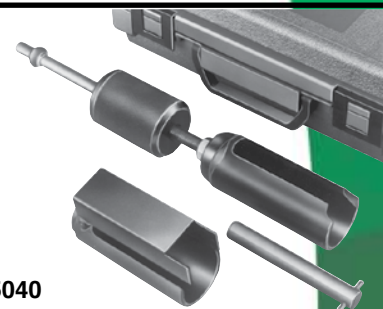

Cummins® Fuel Injector Puller Adapter

When combined with our No. 5028 injector puller or a slide hammer with a 1/2"-20 threaded shaft, this adapter gives you an easy, damage-free way to remove fuel injectors from Cummins B and C series engines.

No. 217793 – Cummins fuel injector puller adapter for B and C series engines with 12 mm x 1.5 injector threads. Wt., 5 oz.

No. 215844 – Cummins fuel injector puller adapter for B and C series engines with 14 mm x 1.5 injector threads. Wt., 5 oz.

217793

215844



Mack Fuel Injector Nozzle Tool

Here's a handy tool for removing or installing injector nozzles on Mack E-6 4 VH and E-9 4 VH four-valve engines. The puller threads directly into the nozzle holder, and mechanical screw power does the pulling while a cylindrical guide holds the injector steady.

- Includes gauge to ensure correct injector depth during installation.

No. 7455 – Mack fuel injector nozzle tool.
Wt., 2 lbs., 2 oz.

7455



HEAVY-DUTY TOOLS

Fuel and Injector Tools



7117

Caterpillar Fuel Injector Nozzle Puller

We've designed this nozzle puller to remove pencil nozzles on Cat engines. The tool applies straight, even pulling power through a bridge assembly and mechanical forcing screw. The job is done quickly— and without damage.

- Works on Caterpillar 1100/3208 diesel engines.

No. 7117 – Caterpillar fuel injector nozzle puller.
Wt., 1 lb., 13 oz.



7121

Fuel Injector Nozzle Puller

We've designed this puller to remove the pencil-type fuel injector nozzles used in many agricultural and construction engines. The slide hammer action gives a straight, even pull without damaging components.

- Works on Case, Caterpillar, GM, John Deere, Waukesha, and White diesel engines.

No. 7121 – Fuel injector nozzle puller.
Wt., 2 lbs., 5 oz.



5028

Slide Hammer Puller

The No. 5028 slide hammer is just 8-1/2" long to fit into tight spots, but its 1-1/2 pound hammer gives you a little extra muscle for stubborn jobs. It's perfect for pulling injector nozzles. The shank is threaded 1/2" –20 and has a 5/8" –18 threaded adapter included. Works with many OTC pulling attachments.

No. 5028 – Slide hammer puller.
Wt., 2 lbs.



218163

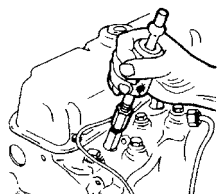

Ford Fuel Injector Puller Adapter

Designed to work with the No. 5028 slide-hammer puller, this adapter removes injectors from Ford 6.6L and 7.8L diesel engines without damage.

- Slide-hammer threads are 1/2" x 20. Threaded end for injector is 14 mm x 1.5.

No. 218163 – Ford fuel injector puller adapter.
Wt., 3 oz.



7458

Bosch Nozzle Socket

Here's a helpful multipurpose tool for removing or installing injector nozzles. You use the inner socket to hold the nozzle stationary, and the outer socket to loosen or tighten the nozzle's gland nut.

- Works on Bosch KDEL 21 mm injector nozzles used in John Deere engines.

No. 7458 – Bosch nozzle socket. Wt., 11 oz.

Fuel Injector Pump Rotating Tool

Maximum fuel economy requires precise injector timing. The tool securely grips the front of the fuel injection pump so you can rotate it while fine-tuning the system.

- Works on Stanadyne rotary fuel pumps found on International's 6.9 and 7.3 liter engines.

No. 7461 – Fuel injection pump rotating tool. Wt., 1 lb., 14 oz.

Similar to
Ford No. 303-228
(T83T-9000-C)



Diesel Fuel Line Wrenches

Fuel line nuts are often hard to reach, but these unique 3/8" square-drive tools solve that problem. With them, you can loosen or tighten fuel lines at the fuel injector nozzle or fuel injection pump without damaging the nut.

No. 7453A – Fuel line wrench, 2.6" long. For International DT466 and 9L diesel engines. Fits 19 mm fuel line nuts. Wt., 4 oz.

No. 7460 – Fuel line wrench, 2.6" long. For International 6.9L and 7.3L diesel engines. Fits 5/8" hex nut. Wt., 5 oz.

Similar to
Ford No. 303-230
(T83T-9396-A)

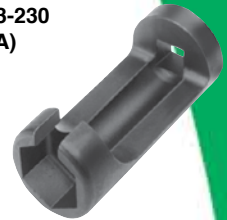

Injector Seat Cleaner

Carbon buildup on an injector seat surface prevents proper seating of new injectors. With this tool, you'll be able to clear away carbon deposits and avoid seating problems.

- Works on 6.9L and 7.3L Ford/Navistar diesels.
- Thread size is 24 mm x 2-6g.

No. 5023 – Injector seat cleaner. Wt., 10 oz.

Similar to
Ford No. 303-232
(T83T-9527-A)

5023



Injector Sleeve Set

Here are the ideal tools for removing and installing the injector sleeves of International DT466 engines. The removing tool threads onto a slide hammer with 5/8" - 18 threads to remove sleeves quickly. The installer seats new sleeves equally fast, without damage.

No. 5024 – Injector sleeve set. Wt., 1 lb., 8 oz.



Calibration Fluid

- For use in diesel injection pump testers and injector nozzle testers, such as our Nos. 4200 Nozlrater and No. 4210 Nozlrater II.

- 1 gallon

No. 208629 – Calibration fluid. Wt., 7 lbs.



208629

HEAVY-DUTY TOOLS

Injector Nozzle Tester Tools



4200

Specifications	
Overall width	5-3/4"
Overall length (includes handle)	26"
Overall height	11-1/4"
Weight (empty)	15 lbs., 10 oz.
Max. pressure	5000 PSI (350 bar)
Max. reservoir cap.	.692 gal. of diesel fuel (160 cu. in.)
Usable reservoir cap.	.628 gal. of diesel fuel (145 cu. in.)
Outlet port	For 3/8" tube
Gauge	Calibrated 0-5000 PSI (350 bar) Has 3-1/2" dial face with maximum reading indicator needle.
Gauge connection	1/4" NPT internal
Stroke of 1/2" dia. piston	3/4"
Volume per full stroke	.147 cu. in. (2.4 cc)
Intake filter	2 micron

Nozlrater Diesel Injector Nozzle Tester

Here is the ultimate tool for diagnosing a number of problems that affect diesel fuel injector nozzles. The Nozlrater tester enables you to check for leakage, pop-off pressure, spray pattern, and chatter. This tool will accommodate a wide range of injectors. We also offer adapters so you can troubleshoot nozzles used in popular automotive, agricultural, and construction engines. Nozlrater features a rugged, lightweight reservoir that holds 7/10 of a gallon of fuel. It is equipped with a replaceable 2-micron filter. The large, dual-scale, high-pressure gauge is protected by a guard and includes an indicator needle to record maximum pressure reached. The tester is light enough to be easily carried for field use. Or you can bench-mount it, using the holes in its base.

- Not designed for Cummins or Detroit injectors.

No. 4200 – Nozlrater diesel injector nozzle tester. 5000 PSI maximum pressure capacity. Wt., 15 lbs., 10 oz.

No. 17169 – Replacement filter. Wt., 1 oz.

No. 11565 – Gauge. Wt., 10 oz.



4202

Nozzle Tester Manifold/Adapter Sets

These adapter sets expand our No. 4200 Nozlrater to troubleshoot a wide range of diesel engine injector nozzles.

No. 4202 – Adapters for servicing Audi, GM, Mercedes-Benz, Nissan/Datsun, Toyota, and VW Rabbit diesel engines. Wt., 2 lbs., 14 oz.

No. 4203 – Manifold/adapter set. Tests Caterpillar high- and low-pressure, capsule-type nozzles, and high-pressure, pencil-type nozzles on 1100 and 3200 series engines. Complete with Nos. 39870 and 206168 adapters, low-pressure gauge (up to 1,000 PSI), cap plug and mounting brackets. Wt., 6 lbs., 13 oz.

No. 4203 optional adapters

No.	Description
209197	Adapter to convert the 4203 for testing other high-pressure, pencil-type nozzles with adapters in the 4201 set.
207036	Straight adapter for pencil-type nozzles on 3300 and 3406-B.

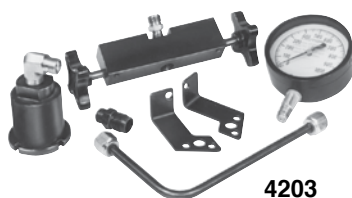

4203

Adapter No.	No. 4202 set includes: Description	Chevy Chevette & GM 1980 & newer C.A.V. nozzles	GM 1979 & newer pencil nozzles	GM 1978 pencil nozzles	Nissan, Toyota, & VW Rabbit Diesels	Audi & Mercedes-Benz
36352	Fuel line assy., 9/16"-18 R.H. thd. with 24° on pipe.	•	•	•	•	•
23617	90° adapter, 9/16"-18 external R.H. thd. (Ermeto 24°) to 9/16"-18 internal R.H. thd. (Ermeto 24°).	•	•	•	•	•
23621	Straight adapter, 9/16"-18 external R.H. thd. (Ermeto 24°) to 1/2"-20 external L.H. thd. (60° seat).	•	•		•	•
23622	Adapter nut, 12 X 1.5 mm internal R.H. thd. to 1/2"-20 internal L.H. thd.	•			•	•
201917	Adapter nut, 9/16"-18 internal R.H. thd. to 1/2"-20 internal L.H. thd.		•	•		
23693	Straight adapter, 1/2"-20 external L.H. thd. (Ermeto 24° & 90° seat) to 9/16"-18 external R.H. thd. (Ermeto 24°).			•		

Nozzle-Tester Adapter Set

This is our universal adapter set for testing injection nozzles on the most popular automotive, agricultural, and construction diesel engines. The set has 17 adapters that connect to our No. 4200 Nozlrater testing unit.

- Includes handy metal storage box.
- 23622— used on 1989–95 Cummins 5.9L, 1983–94 Ford 6.9L and 7.3L.
- 23623— used on 1996–2000 Cummins 5.9L and Navistar 6.6L and 7.8L

No. 4201 – Nozzle-tester adapter set.
Wt., 4 lbs., 2 oz.



4201

Adapter No.	No. 4201 Application Chart		I.H. Truck	I.H. Farm Construction	John Deere	Oliver & Allis	Waukesha	Case, Ford Tractor, Massey, & Perkins	White	Mack	Caterpillar Pencil Nozzles	Deutz	GM Autos	VW, Audi, & Mercedes Autos	Mercedes & Magaris Truck
	Description														
36352		Fuel line assembly, 9/16"–18 R.H. thd. with 24° on pipe.	•	•	•	•	•	•	•	•	•	•	•	•	•
23622		Adapter nut, 12 X 1.5 mm internal R.H. thd. to 1/2"–20 internal L.H. thd.	•		•	•	•	•	•			•	•	•	
23623		Adapter nut, 14 X 1.5 mm internal R.H. thd. to 1/2"–20 internal L.H. thd.	•	•	•	•	•	•		•					•
23624		Adapter nut, 18 X 1.5 mm internal R.H. thd. to 1/2"–20 internal L.H. thd.		•		•	•	•							
201917		Adapter nut, 9/16"–18 internal R.H. thd. to 1/2"–20 internal L.H. thd.	•	•	•	•	•	•	•				•		
23626		Adapter nut, 5/8"–18 internal R.H. thd. to 1/2"–20 internal L.H. thd.	•	•		•	•	•							
201912		Adapter nut, 3/4"–16 internal R.H. thd. to 1/2"–20 internal L.H. thd.					•								
201913		Adapter nut, 9/16"–24 internal R.H. thd. to 1/2"–20 internal L.H. thd.	•	•											
23693		Straight adapter, 1/2"–20 external L.H. thd. (Ermeto 24° & 90° seat) to 9/16"–18 external R.H. thd. (Ermeto 24°).	•	•	•	•	•	•	•				•		
23692		Straight adapter, 3/8"–24 external R.H. thd. to 9/16"–18 external R.H. thd. (internal Ermeto 24°).	•	•											
23617		90° adapter, 9/16"–18 external R.H. thd. (Ermeto 24°) to 9/16"–18 internal R.H. thd. (Ermeto 24°).	•	•	•	•		•	•	•		•	•	•	•
23621		Straight adapter, 9/16"–18 external R.H. thd. (Ermeto 24°) to 1/2"–20 external L.H. thd. (60° seat).	•	•	•			•	•	•		•	•	•	•
208370		Banjo adapter, 9/16"–18 external R.H. thd. (24° seat).		•	•										
201916		Adapter, 9/16"–18 external R.H. thd. to 9/16"–18 internal R.H. thd. ferrule.			•										
208369		90° adapter, 9/16"–18 external R.H. thd. to 9/16"–18 internal R.H. thd.	•												
38279		Straight adapter, 14 X 1.5 mm external R.H. thd. (Ermeto 60°) to 9/16"–18 external R.H. thd. (internal Ermeto 24°).			•										
43468		Straight adapter, 1/2"–20 external R.H. thd. (Ermeto 24°) to 9/16"–18 external R.H. thd. (internal Ermeto 24°).							•						
Additional Accessories Available (not included in 4201 Set)															
44026		Straight adapter, 9/16"–18" R.H. thd. (Ermeto 24°) to Caterpillar 1100 & 3200 series pencil nozzle.									•				
201920		Adapter nut, 14 X 1.5 mm external thd. to o"–18 internal R.H. thread	Connects OTC 4200 Nozlrater to other fittings used in the industry.												
309277		Adapter nut, 14 X 1.5 mm internal thread	For use only on Mack 4-valve diesels. (E6 & E9)												

HEAVY-DUTY TOOLS

Injector Nozzle Tester Tools



4210

Specifications:

Overall width	5-3/4"
Overall length (incl. handle)	15"
Overall height	10-3/4"
Weight (empty)	13 lbs., 15 oz.
Maximum pressure	5000 PSI (350 bar)
Max. reservoir capacity	.68 gal. (157 cu. in.)
Usable reservoir capacity	.58 gal. (134 cu. in.)
Outlet port	For 1/4" tube
Gauge	Dual calibrated, 0-5000 PSI, 0-350 bar, 1% accuracy, 2-1/2" dial with dual scale (PSI & bar).
Gauge connection	1/4" NPTF
Stroke of 1/2" dia. piston	5/8"
Volume per full stroke	1 cc
Intake filter	2 micron

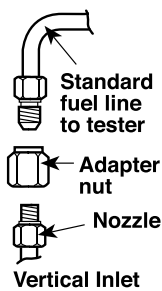
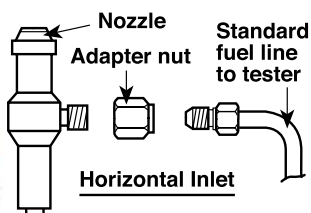

Nozlrater® II Injector Nozzle Tester

The No. 4210 tests the small injector nozzles used in smaller car and light-truck engines. It enables you to diagnose leakage, pop-off pressure, spray pattern, and chatter. It has a .68-gallon reservoir and is equipped with a replaceable 2-micron filter. It delivers 1cc of fuel per stroke and won't flood small nozzles. The unit is light enough to be easily carried for field use, or you can bench-mount it.

- Includes fittings, fuel line, and 5,000 PSI (350 bar) gauge.
- Works on nozzles from Audi, GM, Mercedes-Benz, Nissan/Datsun, Toyota, and VW Rabbit diesels.

No. 4210 – Nozlrater II injector nozzle tester. Wt. 13 lbs., 15 oz.

No. 17169 – Replacement filter. Wt., 1 oz.

No. 303292 – Gauge. Wt., 6 oz.

Accessory Fittings (for use with, but not included with, No. 4210 Nozlrater® II)

No.		Description
303570		Fuel line used on nozzles with 90° horizontal inlets. 1/2"-20 internal R.H. thread to 1/2"-20 external L.H. thread (60° seat).
23624		Adapter nut, 18 X 1.5 mm internal R.H. thread to 1/2"-20 internal L.H. thread.
201917		Adapter nut, 9/16"-18 internal R.H. thread to 1/2"-20 L.H. internal thread.
23626		Adapter nut, 5/8"-18 internal R.H. thread to 1/2"-20 internal L.H. thread.
201912		Adapter R.H. thd. to 1/2"-20 internal L.H. thread.
201913		Adapter nut, 9/16"-24 internal R.H. thread to 1/2"-20 internal L.H. thread.
208384		Used to adapt standard fuel lines to the following adapters.
23693		Straight adapter, 1/2"-20 external L.H. thread (Ermeto 24° and 90° seat) to 9/16"-18 external R.H. thread (Ermeto 24°).
201916		Adapter, 9/16"-18" external R.H. thread to 9/16"-18 internal R.H. thread ferrule.
38279		Straight adapter, 14 X 1.5 mm external R.H. thread (external 60° seat) to 9/16"-18 external R.H. thread (internal Ermeto 24°).
43468		Straight adapter, 1/2"-20 external R.H. thread (Ermeto 24°) to 9/16"-18 external R.H. thread (internal Ermeto 24°).
44026		Straight adapter, 9/16"-18 external R.H. thread (Ermeto 24°) to Caterpillar 1100 & 3200 series pencil nozzle.

Adapter No.	Description	GM 1980 & Newer Poppet Nozzles	GM 6.2L Diesels	Chevy Chevette	Audi & Mercedes-Benz	Datsun, Toyota, & VW Rabbit	1989-95 5.9L Dodge (Cummins)	1996-2000 5.9L Dodge (Cummins)	1983-94 6.9L & 7.3L Ford (with Navistar)	6.6L & 7.8L Ford (with Navistar)
23622	Adapter nut, 12 X 1.5 mm female R.H. thd. to 1/2"-20 internal L.H. thd.	•		•	•	•	•		•	
23623	Adapter nut, 14 X 1.5 mm female R.H. thd. to 1/2"-20 internal L.H. thd.		•					•		•
201917	Adapter nut, 9/16"-18 internal R.H. thd. to 1/2"-20 internal L.H. thd.									GM 1979 & Newer Pencil Nozzles (not included with 4210)