

# **TOOLS UNLIMITED**

**1-800-537-1993**

## **Michigan Pneumatic PDF Section 2**

### **Table of Contents**

<b>Index</b>	<b>Page</b>
<b>Angle &amp; General Line Drills</b>	<b>3</b>
<b>Aircraft &amp; General Line Drills</b>	<b>4</b>
<b>Aircraft Drills</b>	<b>5</b>
<b>Aircraft Drill Accessories</b>	<b>6</b>
<b>Floor Drill &amp; Industrial-Duty Drills</b>	<b>7</b>
<b>Industrial-Duty Drills</b>	<b>8</b>
<b>Heavy-Duty Drill &amp; Wood Borers</b>	<b>9 - 10</b>
<b>Heavy-Duty Drill Accessories</b>	<b>11</b>
<b>Nutrunners &amp; Drill Accessories</b>	<b>12</b>
<b>Extra Heavy-Duty Drills &amp; Wood Borers</b>	<b>13</b>
<b>Heavy-Duty Corner Drills</b>	<b>14</b>
<b>Drill Chucks</b>	<b>15</b>
<b>Magnetic Drill &amp; Cutters</b>	<b>16</b>
<b>Rock Drills &amp; Accessories</b>	<b>17</b>
<b>Drill Steel Accessories &amp; Carbide Tipped Drills</b>	<b>18</b>
<b>High Speed Grinders</b>	<b>19</b>
<b>Angle Die Grinders</b>	<b>20</b>

Visit us on the web at [www.ToolsUnlimited.com](http://www.ToolsUnlimited.com)

# Table of Contents

<b>Index</b>	<b>Page</b>
<b>Automotive Die Grinders</b>	<b>21</b>
<b>Industrial Die Grinders</b>	<b>22</b>
<b>Rivet Shaver &amp; Routers</b>	<b>23</b>
<b>Industrial Die Grinders</b>	<b>24</b>
<b>Collet Adapters, Extensions, Assemblies, Nuts, Inserts</b>	<b>25 - 27</b>
<b>Disc Sander</b>	<b>28</b>
<b>Random Orbital Sanders</b>	<b>29 - 30</b>
<b>Gear Driven Sanders &amp; Buffers</b>	<b>31</b>
<b>Vertical Sanders &amp; Buffers</b>	<b>32</b>
<b>Belt &amp; Pad Sanders</b>	<b>33 - 35</b>
<b>Straight-Line Sanders</b>	<b>36</b>
<b>Extended Arbor Grinders</b>	<b>37</b>
<b>Wheel Grinders &amp; Belt Attachments</b>	<b>38</b>
<b>Wheel Grinders - Industrial</b>	<b>39</b>
<b>Straight Wheel Grinders - Industrial</b>	<b>40</b>
<b>Right Angle Grinders &amp; Sanders</b>	<b>41 - 43</b>
<b>Specialty Grinders / Sanders</b>	<b>44</b>
<b>Vertical Grinders</b>	<b>45 - 46</b>
<b>Grinder &amp; Sander Accessories</b>	<b>47 - 48</b>
<b>Miscellaneous Tools</b>	<b>49</b>

Visit us on the web at [www.ToolsUnlimited.com](http://www.ToolsUnlimited.com)

**TOOLS  
UNLIMITED**  
1-800-537-1993



# Angle & General Line Drills



## Michigan Pneumatic Model MP-31DR-ST

### 1/4" Air Drill - Reversible

Features a forward/reverse switch and a two-speed trigger. Durable composite motor housing and planetary gear system with needle bearings makes for a versatile, lightweight design well-suited for multiple applications. Replacement Jacobs SM1G61-T1 Multi-Craft® chuck available.

Drilling Capacity .....	1/4"	Length.....	5-13/16"
Free Speed .....	2600 rpm	Weight.....	1.30 lbs.
Spindle Thread .....	3/8"-24	Air Inlet Thread .....	1/4"
Rec'd Hose Size .....	1/4"	Avg. Air Consumption .....	4 cfm



## Michigan Pneumatic Model MP-1403

### 1/4" Palm Drill - Non-Reversible

Ideal for aircraft repair and maintenance work. Small and lightweight design to fit in the palm of the hand. Replacement Jacobs SM1G61-T1 Multi-Craft® chuck available.

Drilling Capacity .....	1/4"	Length.....	6-7/64"
Free Speed .....	3000 rpm	Weight.....	1.76 lbs.
Spindle Thread .....	3/8"-24	Air Inlet Thread .....	1/4"
Rec'd Hose Size .....	1/4"	Avg. Air Consumption .....	4 cfm



MP-2100-ST

## Michigan Pneumatic

### 3/8" Straight Drills - Non-Reversible

Designed with a three-way planetary gear reduction system for drilling the thickest metal or wood. Housed in a lightweight, rugged aluminum handle. Equipped with Jacobs SM1G61-T1 Multi-Craft® chuck.

Model	MP-2100-ST	MP-2145-ST
Drilling Capacity	3/8"	3/8"
Free Speed	2200 rpm	4500 rpm
Spindle Thread	3/8"-24	3/8"-24
Length	8-1/2"	7-1/2"
Weight	2 lbs.	2 lbs.
Air Inlet Thread	1/4"	1/4"
Avg. Air Consumption	4 cfm	4 cfm



3-3/4"

## Michigan Pneumatic Model MP-500AH-ST

### 3/8" Angle Drill - Non-Reversible

Right angle drill is designed to get into hard to reach areas where pistol types are not accessible. Durable and lightweight. Equipped with Jacobs SM4G61-T1 Multi-Craft® chuck.

Drilling Capacity .....	3/8"	Length.....	7-1/4"
Free Speed .....	1900 rpm	Weight.....	2 lbs.
Spindle Thread .....	3/8"-24	Air Inlet Thread .....	1/4"
Rec'd Hose Size .....	1/4"	Avg. Air Consumption .....	4 cfm



3-1/2"

## Michigan Pneumatic Model MP-510AH-ST

### 3/8" Angle Drill - Reversible

90° right angle drill is designed to get into hard to reach areas. Lightweight, compact, reversible, with variable speed control for most drilling applications. Equipped with Jacobs SM4G61-T1 Multi-Craft® chuck.

Drilling Capacity .....	3/8"	Length.....	8-1/4"
Free Speed .....	1400 rpm	Weight.....	2 lbs.
Spindle Thread .....	3/8"-24	Air Inlet Thread .....	1/4"
Rec'd Hose Size .....	1/4"	Avg. Air Consumption .....	4 cfm

# Aircraft & General Line Drills



## Michigan Pneumatic Model MP-31D-ST

### 1/4" Palm Drill - Non-Reversible

Ideal for aircraft repair and maintenance work. Small and lightweight design to fit in the palm of the hand. Replacement Jacobs SM1G61-T1 Multi-Craft® chuck available.

Drilling Capacity .....	1/4"	Length.....	5-5/8"
Free Speed .....	2800 rpm	Weight.....	1.3 lbs.
Spindle Thread .....	3/8"-24	Air Inlet Thread.....	1/4"
Rec'd Hose Size .....	1/4"	Avg. Air Consumption.....	4 cfm



## Michigan Pneumatic Model MP-7802-ST

### 3/8" Pistol Drill - Non-Reversible

Lightweight drill designed with a full planetary gearing system for hole sawing and precision drilling. Ideal for production use. Equipped with Jacobs SM4G61-T1 Multi-Craft® chuck.

Drilling Capacity .....	3/8"	Length.....	6-1/2"
Free Speed .....	2200 rpm	Weight.....	2.5 lbs.
Spindle Thread .....	3/8"-24	Air Inlet Thread.....	1/4"
Rec'd Hose Size .....	3/8"	Avg. Air Consumption.....	4 cfm



## Michigan Pneumatic Model MP-7803-ST

### 1/2" Pistol Drill - Non-Reversible

Lightweight drill designed with a full planetary gearing system for hole sawing and precision drilling. Ideal for production use. Equipped with Jacobs SM4G61-T1 Multi-Craft® chuck and dead handle.

Drilling Capacity .....	1/2"	Length.....	7"
Free Speed .....	500 rpm	Weight.....	4 lbs.
Spindle Thread .....	3/8"-24	Air Inlet Thread.....	1/4"
Rec'd Hose Size .....	3/8"	Avg. Air Consumption.....	4 cfm



## Michigan Pneumatic Model MP-525-ST

### 3/8" Pistol Drill - Reversible

Lightweight with a controllable teasing trigger. Features a 1/2 HP motor with a super quiet handle exhaust. Applications include screwdriving, honing and reaming. Equipped with Jacobs SM4G61-T1 Multi-Craft® chuck. QC-50 1/4" hex screwdriver adapter available.

Drilling Capacity .....	3/8"	Length.....	6-1/2"
Free Speed .....	2000 rpm	Weight.....	2.5 lbs.
Spindle Thread .....	3/8"-24	Air Inlet Thread.....	1/4"
Rec'd Hose Size .....	1/4"	Avg. Air Consumption.....	4 cfm



## Michigan Pneumatic Model MP-527-ST

### 1/2" Pistol Drill - Reversible

Double geared drill handles the toughest chores. Features a teasing action trigger for speed control. Great for screwdriving, tapping and hole sawing. Equipped with Jacobs SM8K61-T1 Multi-Craft® chuck and dead handle. QC-50 1/4" hex screwdriver adapter available.

Drilling Capacity .....	1/2"	Length.....	7-1/2"
Free Speed .....	500 rpm	Weight.....	3.25 lbs.
Spindle Thread .....	3/8"-24	Air Inlet Thread.....	1/4"
Rec'd Hose Size .....	3/8"	Avg. Air Consumption.....	4 cfm



# Aircraft Drills



Michigan Pneumatic

## 45° & 90° Angle Drills - Non-Reversible



Features rear exhaust. Milled motor housing, steel alloy cylinder and rotor for long tool life. Available in standard or extended length head with 45° or 90° angle. Precision machined for smooth and quiet operation. **Models MP-9039EXT and MP-9039EXT-45 with 9/32"-40 internal spindle thread also available. (Bit not included.)**

Model No.	Head Angle	Drilling Capacity	Free Speed	Internal Spindle Thread	Length	Weight	Rec'd Hose Size	Air Inlet Thread	Avg. Air Consumption
MP-9030	90°	1/4"	3000 rpm	1/4"-28	10-11/16"	1.90 lbs.	1/4"	1/4"	7.0 cfm
MP-3045	45°				10-29/32"	1.90 lbs.			
MP-9030EXT	90°				13-3/8"	2.00 lbs.			
MP-9030EXT-45	45°				14-7/8"	2.00 lbs.			



### Michigan Pneumatic Model MP-3603

#### 360° Drill - Non-Reversible



Lightweight, powerful drill ideal for aircraft and sheet metal repair. Designed for 1/4"-28 threaded bits. Features a rear exhaust and easy maneuverability to minimize operator fatigue. Milled motor housing, steel alloy cylinder and rotor for long tool life.

Drilling Capacity	1/4"	Length	10-5/8"
Free Speed	3000 rpm	Weight	2.0 lbs.
Spindle Thread	1/4"-28 Internal	Air Inlet Thread	1/4"
Rec'd Hose Size	1/4"	Avg. Air Consumption	7 cfm

Bit not included



### Michigan Pneumatic Model MP-FD30261

#### 360° Drill - Non-Reversible

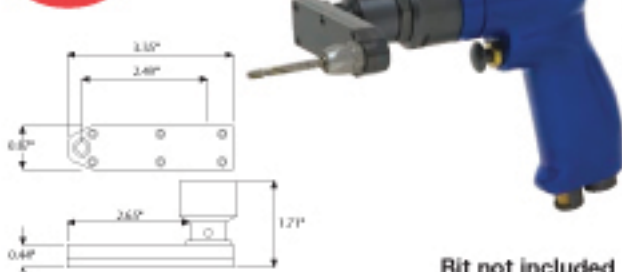

Smooth, quiet design featuring steel alloy cylinder and rotor. Feather trigger for better control. Head may be adjusted to desired angle. **Model MP-FD30161 with straight handle available.**

Drilling Capacity	1/4"	Length	7"
Free Speed	3000 rpm	Weight	2.0 lbs.
Spindle Thread	1/4"-28 Internal	Air Inlet Thread	1/4"
Rec'd Hose Size	1/4"	Avg. Air Consumption	4 cfm

Bit not included



# Aircraft Drill Accessories

Michigan Pneumatic Model MP-309

## Cleco Installation Tool

Ideal for aircraft production assembly and mechanics. Quickly install button type and side grip temporary fasteners. Feather trigger and quiet operation round out the features.



Shown with Cleco fastener (not included.)

Length ..... 5-1/2"  
Weight ..... 1.25 lbs.  
Rec'd Hose Size ..... 1/4"  
Air Inlet Thread ..... 1/4"

## High Speed Drill Bits - 135° Threaded Shank

Produced from Industrial-Grade Steel. Split point penetrates on contact and prevents "walking" of bit. Designed for steel (low and medium carbon), steel alloy and stainless steel. Long and Stubby lengths also available.

- HSS designed for cast iron and steel alloy.
- Cobalt designed for steel (low and medium carbon), steel alloy, and stainless steel alloys.



High Speed Steel Part No.	Cobalt Steel Part No.	Size	Decimal Equivalent	Overall Length
325-40	625-40	#40	0.0980	1"
325-0.125	625-0.125	1/8"	0.1250	1-1/4"
325-30	625-30	#30	0.1285	
325-27	625-27	#27	0.1440	
325-0.1562	625-0.1562	5/32"	0.1562	
325-21	625-21	#21	0.1590	1-1/4"
325-20	625-20	#20	0.1610	
325-16	625-16	#16	0.1770	
325-13	625-13	#13	0.1850	
325-0.1875	625-0.1875	3/16"	0.1875	1-1/4"
325-11	625-11	#11	0.1910	
325-10	625-10	#10	0.1935	
325-0.25	625-0.25	1/4"	0.2500	
325-F	625-F	"F"	0.2570	

## 100° Countersink Cutters

Fits any micro-stop counter sink or angle drill with a 1/4"-28 spindle. Cutter and integral pilot are precision ground.



Pilot Size	Body Diameter		
	7/16"	3/8"	1/2"
#40	328-40	328-38-40	328-12-40
#30	328-30	328-38-30	328-12-30
#27	328-27	-	-
#21	328-21	328-38-21	328-12-21
#10	328-10	328-38-10	328-12-10
1/4"	328-0.25	-	-

## Drill Stops

Helps eliminate the worry of drilling too deep into tubing, wiring, etc.



DS47-1



DS47-2

Part No.	Size	Decimal Equivalent
DS47-0	#50	0.0700
DS47-1	#40	0.0980
DS47-2	#30	0.1285
DS47-22	#27	0.1440
DS47-3	#21	0.1590
DS47-4	#20	0.1610
DS47-42	#16	0.1770
DS47-5	#12	0.1890
DS47-6	#10	0.1935
DS47-7	1/4"	0.2500
DS47-8	5/16"	0.3150

## Micro-Stop Countersinks



### MPT727 - Mini

Designed to be operated in angle drills with a 1/4"-28 spindle. Features a 3/32" shaft travel and a 9/16" cutter capacity. Adjustable in 0.001 increments and rated for use up to 3000 rpm.

### MPT827 - Standard

Features 1/4" shank with 9/32" travel. Will accept up to 1/2" diameter cutters with a 1/4"-28 thread. Rated for up to 3000 rpm and is adjustable in 0.001 increments.

### MPT927 - Ball Bearing

The ball bearing style micro-stop countersink featuring same specifications as Model MPT827. Rated for up to 10000 rpm.



# Floor Drill & Industrial-Duty Drills



**MP-719T Drill**  
Motor Detail

Michigan Pneumatic **Model MP-719T w/ Bubble Level**

## Floor Drill

This drill driver is ideal for self-drilling and self-tapping screws in the truck and trailer industries. Features a lower rpm for higher driving and stall torque. Equipped with Jacobs 33BA-1/2 medium-duty chuck and bubble level.

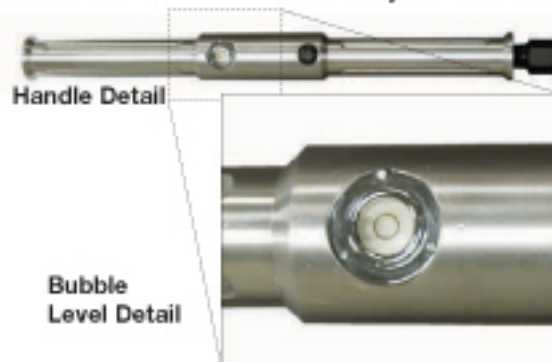

Handle Detail

Bubble Level Detail

Drilling Capacity .....	1/2"	Length .....	32-1/2"
Free Speed .....	1500 rpm	Weight .....	11 lbs.
Spindle Thread .....	1/2"-20	Rec'd Hose Size .....	3/8"
Width of Motor .....	2-3/4"	Air Inlet Thread .....	3/8"
Width w/ Handle .....	17-3/4"	Avg. Air Consumption .....	26 cfm



Michigan Pneumatic **Model MP-8009**

## 3/8" Heavy-Duty Drill - Non-Reversible

Heavy-duty drill ideal for the aircraft industry. Small, lightweight design fits comfortably in the operator's hand. Ease of handling and control ensures optimal drilling performance. **Parts are interchangeable with the ARO Model 7364-D drill.** Equipped with Jacobs 22BA-3/8 industrial-duty chuck.

Drilling Capacity .....	3/8"	Length .....	7"
Free Speed .....	3000 rpm	Weight .....	2.5 lbs.
Spindle Thread .....	3/8"-24	Air Inlet Thread .....	1/4"
Rec'd Hose Size .....	3/8"	Avg. Air Consumption .....	4 cfm



Michigan Pneumatic **Model 15DP-4B - 400 rpm**  
**Model 15DP-8B - 800 rpm**

## 1/2" Heavy-Duty Drill - Non-Reversible

**Industrial model.** Compact, powerful pistol grip drill uses precision machined planetary gears to generate high torque to drill through heavy steel or titanium. Handle exhaust and muffler meet OSHA requirements. **Equipped with Jacobs 33BA-1/2 heavy-duty chuck and dead handle.**

Drilling Capacity .....	1/2"	Length .....	8-1/2"
Free Speed .....	400 or 800 rpm	Weight .....	5.5 lbs.
Spindle Thread .....	1/2"-20	Air Inlet Thread .....	3/8"
Rec'd Hose Size .....	3/8"	Avg. Air Consumption .....	6 cfm



Michigan Pneumatic **Model 15DP-55B - 55 rpm**  
**Model 15DP-1.6B - 160 rpm**

## 1/2" Heavy-Duty Drill - Non-Reversible

**Industrial model.** Precision machined pistol grip drill uses planetary gears to generate high torque to drill through heavy steel or titanium. Handle exhaust and muffler meet OSHA requirements. **Equipped with Jacobs 33BA-1/2 heavy-duty chuck and dead handle.**

Drilling Capacity .....	1/2"	Length .....	9-3/4"
Free Speed .....	55 or 160 rpm	Weight .....	6.0 lbs.
Spindle Thread .....	1/2"-20	Air Inlet Thread .....	3/8"
Rec'd Hose Size .....	3/8"	Avg. Air Consumption .....	6 cfm

# Industrial-Duty Drills



**NPK®**



Nippon Pneumatic **Model NRD-6SAT**

**1/4" Straight Drill - Non-Reversible**

Compact, lightweight drill fits the palm of the hand. Features a lever throttle for safe, easy start up. Ideal for hard to reach drilling areas. Planetary gearing provides sufficient torque for light reaming applications. **Equipped with Jacobs 1B-3/8 medium-duty chuck.**

Drilling Capacity .....	1/4"	Length.....	6-17/32"
Free Speed .....	2800 rpm	Weight.....	1.8 lbs.
Spindle Thread .....	3/8"-24	Air Inlet Thread.....	1/4"
Rec'd Hose Size .....	1/4"	Avg. Air Consumption.....	17.7 cfm

**NPK®**



Nippon Pneumatic **Model NRD-6PBT**

**1/4" Heavy-Duty Drill - Non-Reversible**

Ideal for aircraft and sheet metal repair. Lightweight industrial drill with a teasing throttle for starting holes. Exhausts through the handle to avoid blowing debris. **Equipped with Jacobs 1B-3/8 medium-duty chuck.**

Drilling Capacity .....	1/4"	Length.....	5-7/8"
Free Speed .....	2400 rpm	Weight.....	1.8 lbs.
Spindle Thread .....	3/8"-24	Air Inlet Thread.....	1/4"
Rec'd Hose Size .....	1/4"	Avg. Air Consumption.....	17.7 cfm

**NPK®**



Nippon Pneumatic **Model NRD-10PT**

**3/8" Heavy-Duty Drill - Non-Reversible**

Production drill designed for use on assembly and maintenance applications. Bronze end plates ensure long life and durability. Power-to-weight ratio exceeds similar models. **Equipped with Jacobs 22BA-3/8 industrial-duty chuck.**

Drilling Capacity .....	3/8"	Length.....	6-1/8"
Free Speed .....	2000 rpm	Weight.....	2.4 lbs.
Spindle Thread .....	3/8"-24	Air Inlet Thread.....	1/4"
Rec'd Hose Size .....	1/4"	Avg. Air Consumption.....	19.4 cfm

**NPK®**



Nippon Pneumatic **Model NRD-12PAT**

**1/2" Heavy-Duty Drill - Non-Reversible**

Heavy-duty drill built to take the punishment of continuous production use. Rugged design assures the best possible drilling performance. Smoothness allows for accurate drilling, reaming and tapping. Adjustable handle included. **Equipped with Jacobs 33BA-1/2 heavy-duty chuck.**

Drilling Capacity .....	1/2"	Length.....	7-3/8"
Free Speed .....	1500 rpm	Weight.....	5.7 lbs.
Spindle Thread .....	1/2"-20	Air Inlet Thread.....	1/4"
Rec'd Hose Size .....	3/8"	Avg. Air Consumption.....	23 cfm

**NPK®**



Nippon Pneumatic **Model NRT-8P**

**Reversible Tapper**

Industrial model. Double trigger tapper with two-step quick reverse throttle makes tapping work speedy, leaving a fine finish. **Equipped with NPK Model 6551010080 medium-duty chuck. Model NRT-8P-JTC with Jacobs Tap Chuck available.**

6570000080 Chuck Key

Capacity.....	5/16"	Length.....	7-1/16"
Free Speed .....	1700 rpm	Weight.....	2.6 lbs.
Spindle Thread .....	#1 Jacobs Taper	Air Inlet Thread.....	1/4"
Rec'd Hose Size .....	3/8"	Avg. Air Consumption.....	19.4 cfm

NRT-8P-JTC

Tap not included

See pages 39 & 42 for drill accessories.



# Heavy-Duty Drills & Wood Borers



## Step 1. Select Motor No.

Motor No.	Free Speed	Capacity	
		Drilling	Reaming/ Tapping
NRD-14R NRD-14RU <sup>†</sup>	1100 rpm	9/16"	3/8"
NRD-16R NRD-16RU <sup>†</sup>	900 rpm	5/8"	1/2"
NRD-19R NRD-19RU <sup>†</sup>	750 rpm	3/4"	5/8"
NRD-22R NRD-22RU <sup>†</sup>	600 rpm	7/8"	3/4"

<sup>†</sup> Underwater Motor



NRD-19RWSCT

Nippon Pneumatic

## Heavy-Duty Reversible Drills

Ideal for production work, boasting smooth operation for accurate drilling, reaming, tapping and woodboring. Possesses the lugging power to maintain speed when under load. Powerful and efficient for use in railroad shops, shipyards, tool rooms and all types of construction work. Features ball bearing support for long life. Includes dead handle. Equipped with 1/2" Air Inlet Thread requiring Avg. Air Consumption of 39 cfm. Recommended hose size of 1/2".

- Built-In Lubricator
- 2 Horse Power Motor, 2-3/8" Feed Length

## Example for Ordering

MOTOR NO.	SPINDLE FEED OPTION	THROTTLE OPTION	REAR FEED OPTION	MODEL NO. FOR ORDERING
<b>NRD-19R</b> Step 1	+ <b>W</b> Step 2	+ <b>SCT</b> Step 3	+ <b>**</b> Step 4	= <b>NRD-19RWSCT</b>

\*\*Rear Feed Option omitted per Option Code B exception

See pages 38-39 & 42 for drill accessories.

## Step 2. Select Spindle Option

Option Code	Ordering Exceptions	
#1 Morse Taper	NRD14 Series only (Standard: do not specify)	
2M	NRD-16 thru NRD-22 (Standard: do not specify)	
5C	NRD-14 Series thru NRD-22 Series	
6C or 7C	NRD-19 and NRD-22 Series only	
W	Includes Breast Plate (Step 4)	

## Step 3. Select Throttle Option

--	--

## Step 4. Select Rear Feed Option

Option Code	Ordering Exceptions
Feed Screw	Standard: do not specify
B	Included with Option W (Step 2)

# Heavy-Duty Drills & Wood Borers



## Step 1. Select Motor No.

Motor No.	Free Speed	Capacity	
		Drilling	Reaming/ Tapping
NRD-23R NRD-23RU <sup>†</sup>	700 rpm	15/16"	3/4"
NRD-25R NRD-25RU <sup>†</sup>	570 rpm	1"	7/8"
NRD-28R NRD-28RU <sup>†</sup>	450 rpm	1-1/8"	7/8"
NRD-32LR NRD-32LRU <sup>†</sup>	380 rpm	1-1/4"	1"

<sup>†</sup> Underwater Motor



Nippon Pneumatic

## Heavy-Duty Reversible Drills

Heavy-duty reversible drills are preferred for production work as they have absolute smoothness of operation for accurate drilling, reaming, tapping and nutrunning. They possess the lugging power to keep their speed when under a load. Their power and efficiency makes them ideal tools for use in railroad shops, shipyards, tool rooms and all types of construction work. Features ball bearing support for long life. **Includes dead handle.** Equipped with 3/8" (Safety Lever Throttle) or 1/2" (Self-Closing Roll Throttle) Air Inlet Thread requiring Avg. Air Consumption of 50 cfm. Recommended hose size of 1/2".

- Built-In Lubricator
- Spindle Protection Nut (2M and 3M Spindles only)
- 3 Horse Power, 4" Feed Length

## Example for Ordering

MOTOR NO.	SPINDLE FEED OPTION	THROTTLE OPTION	REAR FEED OPTION	MODEL NO. FOR ORDERING
<b>NRD-23R</b> Step 1	+ *	+ <b>SCT</b> Step 3	+ **	= <b>NRD-23R SCT</b>
	Step 2		Step 4	

\*Spindle Feed Option omitted per Option Code 2M exception \*\*Rear Feed Option omitted per exception

See pages 38-39 & 42 for drill accessories.

## Step 2. Select Spindle Option



Option Code	Ordering Exceptions
2M	NRD-23 Series (Standard: do not specify)
3M	NRD-25 thru NRD-32 (Standard: do not specify)
W	Includes Breast Plate (Step 4)

## Step 3. Select Throttle Option



## Step 4. Select Rear Feed Option



Option Code	Ordering Exceptions
Feed Screw	Standard: do not specify
B	Included with Option W (Step 2)



# Heavy-Duty Drill Accessories



## Morse Taper Arbors



Model	Taper	Drive
A0261	#2 Morse	3/8"-24 Threaded
A0264	#2 Morse	1/2"-20 Threaded
A0268	#2 Morse	5/8"-16 Threaded
R33W-151-0.50	#2 Morse	Woodboring Chuck
R33SW-151A-0.50	#3 Morse	Woodboring Chuck
2MTX12SQ	#2 Morse	1/2" Square
3MTX12SQ	#3 Morse	1/2" Square
3MTX34SQ	#3 Morse	3/4" Square
33SH-214	#3 Morse	3/4" Square
5MTX1SQ	#5 Morse	1" Square



## MP-222 Accessories



## Other Manufacturer Accessories



## Jacobs® Arbors

Morse taper to Jacobs® taper arbors can be used to adapt any Morse taper drill to accept Jacobs® chucks. These adapters improve drill operation and make drill bit changes quicker.

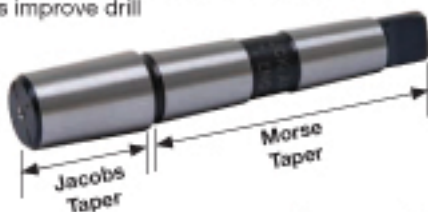

Jacobs® Taper	#1 Morse Taper	#2 Morse Taper	#3 Morse Taper	#4 Morse Taper	#5 Morse Taper
	Model	Model	Model	Model	Model
1JT	A0101	A0201	A0301	-	-
2JT	A0102	A0202	A0302	A0402	-
3JT	-	A0203	A0303	A0403	A0503
4JT	-	A0204	A0304	A0404	A0504
5JT	-	-	A0305	A0405	A0505
6JT	A0106	A0206	A0306	A0406	-
33JT	A0133	A0233	A0333	A0433	-

See pages 39 & 42 for additional drill accessories.

# Nutrunners & Drill Accessories



## Jacobs® Tap Chucks

Full range of tap chucks for tapping machines and portable tappers.

- Designed for use with Rubber-Flex® collets
- Positive-drive chuck jaws for superior performance
- Simple quarter turn of chuck screw to disengage back jaws



### Tap Chuck Specifications

Model No.	Tap Capacity	Mount Style	Overall Length	Maximum Diameter	Round Shank Capacity		Available Rubber-Flex® Collets †	Weight
					Minimum	Maximum		
41-01	# 0-1/4"	1JT*	2.00"	0.84"	0.09"	0.25"	J116, J117	2 oz
42-01	#10-5/16"	1JT*	2.50"	1.06"	0.09"	0.38"	J420, J421, J422, J423	6 oz
42-02	#10-5/16"	2 short JT*	2.50"					5 oz
42-24	#10-5/16"	0.3675 Dia.	2.50"					6oz
42-J8	#0-1/4"	0.375 Sq. Hole	2.31"					6 oz
44-02	5/16-5/8"	2JT*	3.12"	1.47"	0.11"	0.50"	J440, J441, J443	12 oz
44-06	5/16-5/8"	6JT*						
44-J9	#10-1/2"	0.500 Sq. Hole						

\* Jacobs® Taper

† Rubber-Flex® Collets are not included. Must be ordered separately.

## Jacobs® Rubber-Flex® Collets

Outperform conventional split-steel collets in gripping power, accuracy and durability.

- Durable one-piece construction
- Precision ground steel jaw inserts assuring maximum grip
- Seals collets and machine spindles to protect from abrasive particles

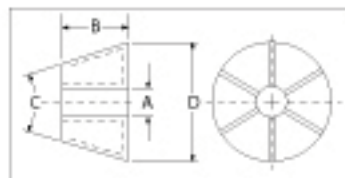

### Rubber-Flex® Collet Specifications

Model No.	Capacity Range (A)		Contact Length (B)	Cone Angle (C)	Outside Diameter (D)	Number of Inserts
	Minimum	Maximum				
J116	0.094"	0.177"	0.468"	26°	0.590"	6
J117	0.177"	0.256"				8
J420	0.176"	0.320"	0.500"	40°	0.941"	6
J421	0.139"	0.257"				6
J422	0.253"	0.383"				6
J423	0.090"	0.180"				4
J440	0.280"	0.500"	0.630"	45°	1.296"	6
J441	0.176"	0.383"	0.630"			6
J443	0.110"	0.280"	0.620"			4

### Replacement Parts

Model No.	Nut	Rubber-Flex® Collet	Back Jaws	Nut Wrench	Body Wrench
41-01	N410	J116, J117	U400	K400N	K400B
42-01	N421	J420, J421, J422, J423	U420	K420N	K420B
42-02					None
42-J8					None
42-24					K420B
44-02	N441	J440, J441, J443	U440	K440N	K420N
44-06					K420N
44-J9					None



### Michigan Pneumatic Model MP-6-1015-0075

#### Nutrunner - 3/4" Square Drive

Lightweight nutrunner featuring high stall torque and reversible drive is ideal for turning valves, tightening, tapping, reaming, pipe beveling or expanding. Compact angle head allows access to confined spaces. Worm gear drive provides high torque and reliability. Equipped with 3/4" square drive. 363394910 1/2" Square Drive Spindle

Square Drive	3/4"	Length	21"
Free Speed	50 rpm	Weight	11 lbs.
Stall Torque	423 ft.-lbs.	Air Inlet Thread	3/8"
Rec'd Hose Size	1/2"	Avg. Air Consumption	45 cfm



### Michigan Pneumatic Model MP-9072RT

#### Right Angle Rolling Motor

Torque-controlled rolling motor designed for the boiler tube industry. Unique head design features enclosed bearing design for long tool life. Engineered to precisely expand tubes in steam drums, fire tubes, and related boiler equipment. Features a roll throttle. Includes dead handle. Tube OD capacity: 1-1/2" to 4".

Square Drive	3/4"	Length	21-3/4"
Free Speed	90 rpm	Weight	14.75 lbs.
Torque Range	150-305 ft.-lbs.	Air Inlet Thread	1/2"
Rec'd Hose Size	3/4"	Avg. Air Consumption	90 cfm



# Heavy-Duty Drills & Wood Borers



Michigan Pneumatic Model MP-222

## Extra Heavy-Duty Drill/Wood Borer

The newest edition to the MPT line of industrial air tools. Ideal for woodboring in marine timbers and railroad repair work. Features include ball bearing support for long life and efficient operation, a graduated roll throttle for speed control, and durable spur gearing. Includes breast plate, dead handle and a built-in lubricator standard. Equipped with 1/2" Air Inlet Thread requiring Average Air Consumption of 50 cfm. Recommended hose size of 1/2"



MP-222KWA1

### Step 1. Select Motor No.

Motor No.	Free Speed	Capacity	
		Drilling	Reaming/Tapping
MP-222J	1025 rpm	9/16"	3/8"
MP-222K	750 rpm	9/16"	7/16"
MP-222M	350 rpm	7/8"	5/8"

### Step 2. Select Spindle Option

A1	A4	A5
A2	A3	WA1
Option Code	Ordering Exceptions	
A5	MP-222M Series only	

### Example for Ordering

MOTOR NO.	SPINDLE FEED OPTION	MODEL NO. FOR ORDERING
<b>MP-222K</b> Step 1	+ <b>WA1</b> Step 2	= <b>MP-222KWA1</b>



Michigan Pneumatic Model MP-33W

## Wood Borer - Reversible

Designed for heavy-duty woodworking. Preferred for wood boring as the operator can easily control the power and speed by the throttle. Powerful, lightweight and easy to handle. Ideal for all types of wood boring, construction work, railroads, shipyards and wharf and pier construction. Uses Ingersoll-Rand 33W wood borer parts.

Capacity .....	2"	Length .....	17-5/8"
Free Speed .....	800 rpm	Weight .....	28.75 lbs.
Morse Taper .....	#2	Air Inlet Thread .....	1/2"
Maximum HP .....	3.00	Spindle Offset .....	1-7/8"

See pages 38-39 & 42 for drill accessories.

# Heavy-Duty Corner Drills



22-82232-5600 Ratchet Wrench

## Michigan Pneumatic Model MP-L-257

### Corner Drill - Non-Reversible

Compact, rugged, powerful design for heavy-duty use in cramped areas. Features positive starting control and sensitive speed variation. Will handle various drilling, reaming and tapping applications. Ideal for assembly plants, refineries and railroad shops. **Other models available with #4 M.T. Uses Thor L-257 corner drill parts. Includes ratchet wrench.**

Capacity.....	29/32" Drilling	Height of Spindle.....	5-7/8"
Free Speed.....	320 rpm	Length.....	19-1/2"
Morse Taper.....	#2	Weight.....	14.125 lbs.
Maximum HP.....	1.40	Spindle Offset.....	1-1/4"



C018072 Ratchet Wrench

## Michigan Pneumatic Model MP-323-3

### Corner Drill - Non-Reversible

Designed for heavy-duty use in cramped areas. Features extra heavy-duty grease packed gearing, hardened ground motor liners, a teasing throttle, feed screws and a governor controlled motor. **Includes ratchet wrench.**

Capacity.....	1" Drilling	Height of Spindle.....	8-1/2"
Free Speed.....	175 rpm	Length.....	26-1/8"
Morse Taper.....	#3	Weight.....	21.5 lbs.
Maximum HP.....	1.50	Spindle Offset.....	1-7/16"



R30-48 Ratchet Wrench

## Michigan Pneumatic Model MP-30

### Corner Drill - Non-Reversible

Strong, powerful close quarters drill built to withstand heavy-duty drilling, reaming and tapping where space is limited. Particularly useful in machine shops, power plants and railroad shops. **Model MP-40 also available with #4 M.T. Uses Ingersoll-Rand 30 corner drill parts. Includes ratchet wrench.**

Capacity.....	1-1/4" Drilling	Height of Spindle.....	8-3/4"
Free Speed.....	185 rpm	Length.....	25-1/4"
Morse Taper.....	#3	Weight.....	33 lbs.
Maximum HP.....	2.80	Spindle Offset.....	1-3/8"



## Michigan Pneumatic Model MP-2-1801-0030

### Corner Drill - Non-Reversible

Applications include heavy-duty drilling, reaming and tapping for railroad cars, refineries, shipyards, structural steel fabrication and wood product industries. Features small side-to-side distance for working in tight spaces, self-closing roll throttle, feed screw and built-in motor oiler.

Capacity.....	1-1/4" Drilling	Height of Spindle.....	7.5"
Load Speed.....	260 rpm	Length.....	22-1/2"
Morse Taper.....	#3	Weight.....	25 lbs.
Maximum HP.....	2.60	Spindle Offset.....	1.4"



## Michigan Pneumatic Model MP-2-2104-0030

### Corner Drill - Reversible

Applications include heavy-duty drilling, reaming and tapping for railroad cars, refineries, shipyards, structural steel fabrication and wood product industries. Features small side-to-side distance for working in tight spaces, self-closing roll throttle, feed screw and built-in motor oiler.

Capacity.....	2-1/8" Drilling	Height of Spindle.....	10"
Load Speed.....	180 rpm	Length.....	23.8"
Morse Taper.....	#4	Weight.....	37 lbs.
Maximum HP.....	3.00	Spindle Offset.....	1.6"



# Jacobs® Drill Chucks



## Jacobs® Multi-Craft® Duty Chucks



Jacobs Model	MPT Model	Capacity (min. - max.)	Threaded Mount	Uses Key
SM1G61-T1	SM1G61-T1	0.028 - 0.250*	3/8"-24	KG1
DC4G61-T1	DC4G61-T1	0.063 - 0.375*	3/8"-24	KG1
DC4G61-T2	DC4G61-T2			
SM4G61-T1	SM4G61-T1			
SM4G61-T2	SM4G61-T2			
032116C	SM8K61-T1	0.078 - 0.500*	3/8"-24	KK
032053C	SM8K64-T1		1/2"-20	

### Thread Mounted Light-Duty Industrial Model

Jacobs Model	MPT Model	Capacity (min. - max.)	Threaded Mount	Uses Key
22BA-3/8	22BA-0.375	0.063 - 0.375*	3/8"-24	KK
22BA-1/2	22BA-0.500		1/2"-20	
24BA-3/8	24BA-0.375	0.063 - 0.500*	3/8"-24	KK
26BA-1/2	26BA-0.500		1/2"-20	

## Jacobs® Plain Bearing Drill Chucks

### Thread Mounted Medium-Duty Model

Jacobs Model	MPT Model	Capacity (min. - max.)	Threaded Mount	Uses Key
0B-5/16	0B-0.312	0.0135 - 0.156*	5/16"-24	K0
1BA-3/8	1BA-0.375	0.040 - 0.250*	3/8"-24	K1
2BA-3/8	2BA-0.375	0.040 - 0.375*	3/8"-24	K2
31BA-3/8	31BA-0.375	0.063 - 0.375*	3/8"-24	K30
41BA-3/8	41BA-0.375	0.040 - 0.375*	3/8"-24	K30
41BA-3/8S <sup>†</sup>	41BA-0.375S <sup>†</sup>		3/8"-24	
41BA-1/2	41BA-0.500		1/2"-20	
33BA-3/8	33BA-0.375	0.078 - 0.500*	3/8"-24	K32
33BA-1/2	33BA-0.500		1/2"-20	
33BA-5/8	33BA-0.625		5/8"-16	

<sup>†</sup> Smooth Sleeve

### Thread Mounted Heavy-Duty Model

Jacobs Model	MPT Model	Capacity (min. - max.)	Threaded Mount	Uses Key
7BA-3/8	7BA-0.375	0.040 - 0.250*	3/8"-24	K7
32BA-1/2	32BA-0.500	0.040 - 0.375*	1/2"-20	K32
34B-5/8	34B-0.625	0 - 0.500*	5/8"-16	K3
34B-45/64	34B-0.703		45/64"-16	
3B-5/8	3B-0.625	0.125 - 0.625*	5/8"-16	K3
3B-45/64	3B-0.703		45/64"-16	
35B-1/2	35B-0.500		1/2"-20	
36B-5/8	36B-0.625	0.188 - 0.800*	5/8"-16	K4
36B-3/4	36B-0.750		3/4"-16	
36B-45/64	36B-0.703		45/64"-16	

## Jacobs® Ball Bearing Super-Duty Chucks

Super ball bearing chucks are the world's most accurate chucks designed for extra heavy-duty drilling. Ideal for close tolerance production drilling on precision equipment.

Jacobs Model	MPT Model	Capacity (min. - max.)	Taper Mount	Uses Key
8-1/2N	8-0.500N	0.040 - 0.250*	2JTS	K30
11N	11N	0.040 - 0.375*	2JT	K32
14N	14N	0.040 - 0.500*	3JT	K3
16N	16N	0.125 - 0.625*	3JT	K4
18N	18N	0.125 - 0.750*	4JT	K4
20N	20N	0.375 - 1.000*	5JT	K5

## Jacobs® HAND-TITE® Keyless Chuck



Jacobs Model	MPT Model	Capacity (min. - max.)	Threaded Mount	Sleeve Type
31451	31451	0.032 - 0.375*	3/8"-24	2 pc
31708-3/8	31708-ASM			
31967	31967			
31993	31993			
31708	31708	0.032 - 0.375*	2JT	2 pc
32000	32000		1/2"-20	1 pc
31731-3/8	31731-ASM	0.062 - 0.500*	3/8"-24	1 pc
31791	31791			2 pc
32161-3/8	32161-ASM			2 pc
32540	32540			2 pc
31403	31403	0.062 - 0.500*	1/2"-20	2 pc
31731	31731			1 pc
32161	32161			2 pc

### Taper Mounted Medium-Duty Model

Jacobs Model	MPT Model	Capacity (min. - max.)	Taper Mount	Uses Key
0	0	0.0135 - 0.156*	0JT	K0
1A	1A	0.040 - 0.250*	1JT	K1
2A	2A	0.040 - 0.375*	2JT	K2
31-01	31-01		1JT	K30
31-02	31-02	2JT	K30	
33	33	0.078 - 0.500*	33JT	K32
33KD **	33KD			

### Taper Mounted Heavy-Duty Model

Jacobs Model	MPT Model	Capacity (min. - max.)	Taper Mount	Uses Key
34-02	34-02	0.040 - 0.500*	2JT	K3
34-06	34-06		6JT	K3
34-33	34-33		33JT	K3
34-33C *	34-33C		33JT	K3C
3A	3A	0.125 - 0.625*	3JT	K3
3KD **	3KD			
3PD ***	3PD			
36	36	0.180 - 0.800*	3JT	K4
36KD **	36KD			
36PD ***	36PD			

\* Equipped with locking collar 1-1/16"-20 thread.

\*\* Equipped with positive drive slot.

\*\*\* Equipped with pin-type positive drive.

## Screwdriver Bit Adapters - Quick Change



Model No.	Shank Size	Threaded Mount
QC-50	1/4" hex	3/8"-24
QC-51	7/16" hex	

See pages 38-39 for additional drill accessories. Stainless steel chucks available in some sizes.

# Magnetic Drill & Cutters



Model MDM-40

Model ECO-80AK

## Magnetic Drill

The MDM-40 features a compact 13" height for drilling in tight spaces and automatic lubrication. A 4-speed gearbox and automatic lubrication are standard on the ECO-80AK. **Other magnetic drills are available in either air or electric versions. See below for annular cutters.**

Model	MDM-40	ECO-80AK
Cutter Capacity	1-1/2"	3-3/16"
Twist Drill Capacity	-	1-1/4"
No Load Speed	440 rpm	100/175/245/385 rpm
Arbor Bore	3/4"	3/4"
Stroke	4-3/8"	10"
Motor Power	9.5 amp/110V	15 amp/110V
Magnetic Force (1" plate)	2640 lbs.	7040 lbs.
Magnet Base Size	6-1/2" L x 3-1/4" W	9" L x 4-3/8" W
Dimensions	13" H x 9-1/2" L x 7" W	19-1/2" H x 13-3/8" L x 7-1/2"
Weight	24 lbs.	57 lbs.

## Annular Cutters



Armor-Plated Unibroach™ Cutters are for use with Hougen, Jancy and other magnetic drilling machines with 3/4" arbor collets. More cutting teeth reduces the individual tooth loading, which extends tool life before resharpening and makes for easier, more efficient cutting of tough materials.

Hole Diameter	Decimal Equivalent	Armor-Plated Titanium Aluminum Nitride (coated TiAlN)		
		For 1" Thick Materials	For 2" Thick Materials	For 3" Thick Materials
		Model No.	Model No.	Model No.
7/16"	0.4375"	81114T	81214T	
1/2"	0.5000"	81116T	81216T	
9/16"	0.5625"	81118T	81218T	
5/8"	0.6250"	81120T	81220T	
11/16"	0.6875"	81122T	81222T	
3/4"	0.7500"	81124T	81224T	81324T
13/16"	0.8125"	81126T	81226T	81326T
7/8"	0.8750"	81128T	81228T	81328T
15/16"	0.9375"	81130T	81230T	81330T
1"	1.0000"	81132T	81232T	81332T
1-1/16"	1.0625"	81134T	81234T	81334T
1-1/8"	1.1250"	81136T	81236T	81336T
1-3/16"	1.1875"	81138T	81238T	81338T
1-1/4"	1.2500"	81140T	81240T	81340T
1-5/16"	1.3125"	81142T	81242T	81342T
1-3/8"	1.3750"	81144T	81244T	81344T
1-7/16"	1.4375"	81146T	81246T	81346T
1-1/2"	1.5000"	81148T	81248T	81348T
1-9/16"	1.5625"	81150T	81250T	81350T
1-5/8"	1.6250"	81152T	81252T	81352T
1-11/16"	1.6875"	81154T	81254T	81354T
1-3/4"	1.7500"	81156T	81256T	81356T
1-13/16"	1.8125"	81158T	81258T	81358T
1-7/8"	1.8750"	81160T	81260T	81360T
1-15/16"	1.9375"	81162T	81262T	81362T
2"	2.0000"	81164T	81264T	81364T
2-1/16"	2.0625"	81166T	81266T	81366T

## Pilots, Arbors & Countersinks

Model No.	Description
73102	Pilot, 1" depth cutter
73202	Pilot, 2" depth cutter
83302	Pilot, 3" depth cutter

Model No.	Description
73902	No. 2 Morse Taper Arbor
73903	No. 3 Morse Taper Arbor
73904	No. 4 Morse Taper Arbor
73910	Countersink, up to 2" hole



# Rock Drills & Accessories



## Michigan Pneumatic Rock Drills

Powerful, heavy-duty rock drills are recommended for heavy industrial maintenance work. The relative lightweight, fast drilling speed, stamina and easy holding of these drills has made them the standard of comparison the world over. A drill of the right weight and power is available for any kind of job. Ideal for continuous service in quarries and mines and highly effective for general excavation work. Equipped with a latch type retainer.

Model No.	Shank Size	Blows Per Minute	Speed	Piston Dia. x Stroke	Overall Length	Weight
MP-RD30-78314	7/8" x 3-1/4"	2450	250 rpm	2-1/8" x 1-3/4"	18-1/2"	31 lbs.
MP-RD30-78414	7/8" x 4-1/4"				19-1/2"	
MP-ERD60-78414	7/8" x 4-1/4"	1800	200 rpm	2-5/8" x 2-9/16"	22-3/8"	60 lbs.
MP-ERD60	1" x 4-1/4"				22-3/8"	
MP-RD60-1	1" x 4-1/4"				22-3/8"	

Accessories listed below and on page 137.

## Rock Drill Steels



Length Under Collar	7/8" hex x 3-1/4" Steel Shank Size		1" hex x 4-1/4" Steel Shank Size	
	"H" Thread	"E" Thread	"H" Thread	"D" Thread
	Part No.	Part No.	Part No.	Part No.
1 ft.	731-H	731-E	141-H	141-D
1-1/2 ft.	73112-H	73112-E	14112-H	14112-D
2 ft.	732-H	732-E	142-H	142-D
2-1/2 ft.	73212-H	73212-E	14212-H	14212-D
3 ft.	733-H	733-E	143-H	143-D
4 ft.	734-H	734-E	144-H	144-D
5 ft.	735-H	735-E	145-H	145-D
6 ft.	736-H	736-E	146-H	146-D
8 ft.	738-H	738-E	148-H	148-D
10 ft.	7310-H	7310-E	1410-H	1410-D

Please specify part number when ordering. Longer lengths and other shank sizes are available.

## Threaded Rock Bits



All Steel



Carbide Insert

Bit Size Diameter	Steel Bit "E" Thread	Steel Bit "H" Thread	Steel Bit "D" Thread	Carbide Bit Single-Use "H" Thread	Carbide Bit Multi-Use* "H" Thread
	Part No.	Part No.	Part No.	Part No.	Part No.
15/16"	LE23				
1"	LE26				
1-1/8"	LE28				
1-1/4"	LE32				
1-3/8"		LH35SH		HSC138	T1207M0
1-1/2"		LH38SH		HSC112	T1507M0
1-5/8"		LH41SH		HSC158	T1607M0
1-3/4"		LH44SH	LD452AH	HSC134	T1707M0
1-7/8"		LH47SH	LD482AH		T1907M0
2"		LH50SH	LD512AH	HSC200	T2007M0
2-1/4"		LH57SH	LD572AH		T2207M0
2-1/2"		LH63SH	LD642AH		T2507M0
2-5/8"		LH66SH			
2-3/4"			LD702AH		HC234
3"			LD762AH		T3007M0
3-1/4"			LD832AH		
3-1/2"			LD892AH		
4"			LD1012AH		

Please specify part number when ordering. Other series and style bits are available.

# Drill Steel Accessories & Carbide Tipped Drills



## 7/8" x 3-1/4" Hex Shank

Part No.	Length Under Collar	Size	Drill Depth
546	9"	5/8"	6"
546-12	12"		9"
546-18	18"		15"
546-24	24"		21"
550	9"	3/4"	6"
550-12	12"		9"
550-18	18"		15"
550-24	24"		21"
550-30	30"	27"	
551	9"	7/8"	6"
551-12	12"		9"
551-18	18"		15"
551-24	24"		21"
551-30	30"	27"	
552	9"	1"	6"
552-12	12"		9"
552-18	18"		15"
552-24	24"		21"
552-30	30"	27"	
553-12	12"	1-1/8"	9"
553-18	18"		15"
553-24	24"		21"
553-30	30"		27"
554-12	12"	1-1/4"	9"
554-18	18"		15"
554-24	24"		21"
554-30	30"		27"
555-12	12"	1-3/8"	9"
555-18	18"		15"
555-24	24"		21"
555-30	30"		27"
556-12	12"	1-1/2"	9"
556-18	18"		15"
556-24	24"		21"
556-30	30"		27"

## 7/8" x 4-1/4" Hex Shank

Part No.	Length Under Collar	Size	Drill Depth
546SP	9"	5/8"	6"
546-12SP	12"		9"
546-18SP	18"		15"
546-24SP	24"		21"
547	9"	3/4"	6"
547-12	12"		9"
547-18	18"		15"
547-24	24"		21"
547-30	30"	27"	
548CD	9"	7/8"	6"
548-12	12"		9"
548-18	18"		15"
548-24	24"		21"
548-30	30"	27"	
549	9"	1"	6"
549-12	12"		9"
549-18	18"		15"
549-24	24"		21"
549-30	30"	27"	
553-12SP	12"	1-1/8"	9"
553-18SP	18"		15"
553-24SP	24"		21"
553-30SP	30"		27"
554-12SP	12"	1-1/4"	9"
554-18SP	18"		15"
554-24SP	24"		21"
554-30SP	30"		27"
555-12SP	12"	1-3/8"	9"
555-18SP	18"		15"
555-24SP	24"		21"
555-30SP	30"		27"
556-12SP	12"	1-1/2"	9"
556-18SP	18"		15"
556-24SP	24"		21"
556-30SP	30"		27"

## Drill Steel Extensions

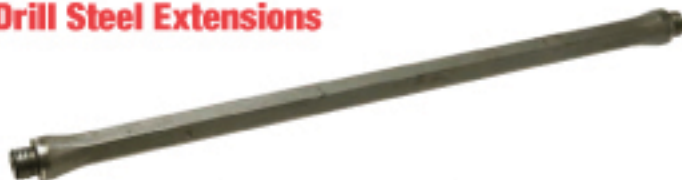

Part No.	Overall Length	Thread
522-2EXT	24"	H
522-3EXT	36"	H
522-4EXT	48"	H
522-5EXT	60"	H
522-6EXT	72"	H
522-8EXT	96"	H

## Adapter & Couplings



Model TH-D  
"H" to "D" Adapter

Model TH-30  
"H" Threaded Coupling

Other adapters and couplings available.

## 1" x 4-1/4" Hex Shank

Part No.	Length Under Collar	Size	Drill Depth
550-12SPL	12"	3/4"	9"
550-18SPL	18"		15"
550-24SPL	24"		21"
550-30SPL	30"		27"
551-12SPL	12"	7/8"	9"
551-18SPL	18"		15"
551-24SPL	24"		21"
551-30SPL	30"		27"
552-12SPL	12"	1"	9"
552-18SPL	18"		15"
552-24SPL	24"		21"
552-30SPL	30"		27"
553-12SPL	12"	1-1/8"	9"
553-18SPL	18"		15"
553-24SPL	24"		21"
553-30SPL	30"		27"
554-12SPL	12"	1-1/4"	9"
554-18SPL	18"		15"
554-24SPL	24"		21"
554-30SPL	30"		27"
555-12SPL	12"	1-3/8"	9"
555-18SPL	18"		15"
555-24SPL	24"		21"
555-30SPL	30"		27"
556-12SPL	12"	1-1/2"	9"
556-18SPL	18"		15"
556-24SPL	24"		21"
556-30SPL	30"		27"

See page 136 for additional accessories.



# High Speed Grinders



## Pencil Style Air Grinders

with Adjustable Throttle

Newly developed pencil grinders are compact, super lightweight and designed to provide greater operator efficiency. Unusually powerful for the toughest jobs. Will grind all materials with amazing speed and ease. Ideal for metal, plastic, wood and stone works. **Not equipped with carbide burrs as shown. Includes 6 ft. exhaust hose.**

Perfect for:

- Finishing metal patterns
- Processing inner and outer surfaces
- Sheet metal working
- Treating after welding
- Finishing precision parts



**MP-SM516**  
Replacement Part  
560021 1/8" Collet



**MP-US3**  
Replacement Part  
US302 1/8" Collet



**MP-US6**  
Replacement Parts  
US602 1/4" Collet  
US602-6mm 6mm Collet

Model No.	Collet Size	Free Speed	Diameter	Length	Weight	Avg. Air Consumption
MP-SM516	1/8"	50000-54000 rpm	0.63"	5.3"	0.24 lbs.	0.78 cfm
MP-US3	1/8"	50000-60000 rpm	0.63"	5.3"	0.24 lbs.	0.78 cfm
MP-US6	1/4"	30000-40000 rpm	0.90"	5.9"	0.60 lbs.	1.10 cfm



### Michigan Pneumatic Model MP-1775-ST

#### Die Grinder - Rear Exhaust

1/4" die grinder features a full bearing support air motor. Equipped with lever throttle for variable speed control. New rear exhaust directs air away from work area.



C-1073-0.125 1/8" Collet 52225 Collet Nut  
C-1073-0.250 1/4" Collet 52227 Wrench (2)

Collet Size.....	1/4"	Length.....	5-1/2"
Free Speed.....	25000 rpm	Weight.....	0.88 lbs.
Maximum HP.....	0.25	Air Inlet Thread.....	1/8"
Rec'd Hose Size.....	1/4"	Avg. Air Consumption.....	3 cfm



### Michigan Pneumatic Model MP-210-AT - Front Exhaust Model MP-220-AT - Rear Exhaust

#### Die Grinder

Small, lightweight grinder is rugged for automotive and industrial work. Quality motor provides power, accuracy and durability. Front exhaust keeps work area clean. Variable speed control for high speed or high torque.



C-1073-0.125 1/8" Collet 220-30 Wrench  
C-1073-0.250 1/4" Collet 220-32 Wrench  
C-1005N Collet Nut

Collet Size.....	1/4"	Length...5-1/2" (MP-210) & 6-5/8" (MP-220)
Free Speed.....	22000 rpm	Weight.....1.25 lbs.
Maximum HP.....	0.30	Air Inlet Thread.....1/4"
Rec'd Hose Size.....	3/8"	Avg. Air Consumption.....4 cfm

See pages 59-61 for grinder accessories.

# Angle Die Grinders



## Michigan Pneumatic Model MP-AG21-ST

### Angle Die Grinder - Front Exhaust

Powerful right angle grinder is designed to get into hard to reach areas where straight types are not accessible. Ideal for use with pressure sensitive discs, mounted points and rotary files for automotive body work. Front exhaust design keeps work area clean. Lightweight for easy handling.

2-7/8"



C-1073-0.125  
C-1073-0.250  
52225  
52227

1/8" Collet  
1/4" Collet  
Collet Nut  
Wrench (2)

Collet Size.....	1/4"	Length.....	4-7/8"
Free Speed.....	20000 rpm	Weight.....	1 lb.
Maximum HP.....	0.5	Air Inlet Thread.....	1/4"
Rec'd Hose Size.....	1/4"	Avg. Air Consumption.....	3 cfm



## Michigan Pneumatic Model MP-2775-ST

### Angle Die Grinder - Rear Exhaust

Rear exhaust die grinder features full bearing angle head construction. New rear exhaust directs air away from work area. Ideal for general purpose grinding in hard to reach areas. Uses pressure sensitive discs and mounted points for automotive body work. Equipped with independent power regulator and variable speed control.

2-7/8"



C-1073-0.125  
C-1073-0.250  
52225  
52227

1/8" Collet  
1/4" Collet  
Collet Nut  
Wrench (2)

Collet Size.....	1/4"	Length.....	5-1/2"
Free Speed.....	22000 rpm	Weight.....	1 lb.
Maximum HP.....	0.4	Air Inlet Thread.....	1/4"
Rec'd Hose Size.....	1/4"	Avg. Air Consumption.....	3 cfm



## Nitto Kohki Model MAS-20B

### Angle Sander/Grinder - Side Exhaust

Ultra compact sander/grinder with a built-in silencer. Ideal for sanding and grinding intricate shapes in cramped areas. Adding the 2" support pad, included, allows the use of 1", 1-1/2" and 2" paper discs in a variety of grits. Simple one touch twist lock speeds paper replacement.

2-27/32"



TP10742  
TA98821-0  
TA98822-0  
5542  
5540

Collet Nut  
1" Support Pad  
1-1/2" Support Pad  
2" Support Pad  
3" Support Pad

Collet Size.....	1/4"	Length.....	5"
Free Speed.....	20000 rpm	Weight.....	1.1 lbs.
Maximum HP.....	0.24	Air Inlet Thread.....	1/4"
Rec'd Hose Size.....	1/4"	Avg. Air Consumption.....	14 cfm



## Michigan Pneumatic Model MP-3040-C

### Angle Die Grinder - Side Exhaust

Industrial grinder excellent for die contouring, deburring and blending in hard to reach areas. Model MP-3040A-C with aluminum motor housing available.

2-1/2"



G-3327  
G-3858  
GA-3858

Wrench  
Wrench  
Collet Nut

Collet Size.....	1/4"	Length.....	8"
Free Speed.....	13500 rpm	Weight.....	2.75 lbs.
Maximum HP.....	1.00	Air Inlet Thread.....	1/4"
Rec'd Hose Size.....	3/8"	Avg. Air Consumption.....	11.9 cfm



## Michigan Pneumatic Model MP-3040E-C

### Extended Angle Die Grinder - Side Exhaust

Extended grinder used in die shops, shipyards, foundries and fabrication shops. Rugged 1 HP motor. Model MP-3040AE-C with aluminum motor housing available.

2-1/2"



G-3327  
G-3858  
GA-3858

Wrench  
Wrench  
Collet Nut

Collet Size.....	1/4"	Length.....	10"
Free Speed.....	13500 rpm	Weight.....	3.20 lbs.
Maximum HP.....	1.00	Air Inlet Thread.....	1/4"
Rec'd Hose Size.....	3/8"	Avg. Air Consumption.....	11.9 cfm

See pages 59-61 for grinder accessories.



# Automotive Die Grinders



C-1073-0.125 1/8" Collet  
 C-1073-0.250 1/4" Collet  
 C-1005N Collet Nut  
 220-30 Wrench  
 220-32 Wrench

## Michigan Pneumatic Model MP-1151B-ST Die Grinder - Rear Exhaust

Comfort cushioned die grinder perfect for delicate finishing work. Features recessed safety lever throttle and top mounted air regulator. Part of the Quiet Tools family of grinders.

Collet Size.....	1/4"	Length.....	7-13/32"
Free Speed.....	20000 rpm	Weight.....	1.50 lbs.
Maximum HP.....	0.25	Air Inlet Thread.....	1/4"
Rec'd Hose Size.....	3/8"	Avg. Air Consumption.....	4 cfm



C-1073-0.125 1/8" Collet  
 C-1073-0.250 1/4" Collet  
 52225 Collet Nut  
 52227 Wrench (2)

## Michigan Pneumatic Model MP-2753-ST Die Grinder - Rear Exhaust

Silenced, 77dB(A), rear exhaust set this tool apart from the rest. Features top mounted air regulator, cushion grip and recessed safety lever throttle.

Collet Size.....	1/4"	Length.....	6-1/8"
Free Speed.....	25000 rpm	Weight.....	1.25 lbs.
Maximum HP.....	0.30	Air Inlet Thread.....	1/4"
Rec'd Hose Size.....	3/8"	Avg. Air Consumption.....	4 cfm



C-1073-0.125 1/8" Collet  
 C-1073-0.250 1/4" Collet  
 52225 Collet Nut  
 52227 Wrench (2)

## Michigan Pneumatic Model MP-2754-ST Die Grinder - Rear Exhaust

Featuring top mounted air regulator and recessed safety throttle lever design gives our extended grinder a leg up on the competition. Perfect for those hard to reach areas. Includes same silenced exhaust as all of the Quiet Tools family.

Collet Size.....	1/4"	Length.....	9-7/8"
Free Speed.....	25000 rpm	Weight.....	1.90 lbs.
Maximum HP.....	0.30	Air Inlet Thread.....	1/4"
Rec'd Hose Size.....	3/8"	Avg. Air Consumption.....	4 cfm



3"

C-1073-0.125 1/8" Collet  
 C-1073-0.250 1/4" Collet  
 52225 Collet Nut  
 52227 Wrench (2)

## Michigan Pneumatic Model MP-7252-ST Angle Die Grinder - Rear Exhaust

Silenced, 77dB(A), rear exhaust set this tool apart from the rest. Features top mounted air regulator, cushion grip and recessed safety lever throttle.

Collet Size.....	1/4"	Length.....	6-11/16"
Free Speed.....	20000 rpm	Weight.....	1.33 lbs.
Maximum HP.....	0.30	Air Inlet Thread.....	1/4"
Rec'd Hose Size.....	3/8"	Avg. Air Consumption.....	4 cfm



3-3/8"

C-1073-0.125 1/8" Collet  
 C-1073-0.250 1/4" Collet  
 52225 Collet Nut  
 52227 Wrench (2)

## Michigan Pneumatic Model MP-7255-ST Angle Die Grinder - Rear Exhaust

115° degree angle grinder features recessed safety lever throttle cushion grip and top mounted air regulator. Silenced, 77dB(A), rear exhaust to reduce tool noise.

Collet Size.....	1/4"	Length.....	7-29/32"
Free Speed.....	20000 rpm	Weight.....	1.40 lbs.
Maximum HP.....	0.30	Air Inlet Thread.....	1/4"
Rec'd Hose Size.....	3/8"	Avg. Air Consumption.....	4 cfm

# Industrial Die Grinders



RG-383

15015309 Collet Nut  
SN-12.7 Wrench  
SN-13 Wrench



RG-38ASLW

G05010K180 Collet Nut  
SN-12.7 Wrench  
SN-15 Wrench



RG-38CX

15015309 Collet Nut  
SN-12.7 Wrench  
SN-13 Wrench

Ideal for the precise, delicate finishing required in handling small points and burrs. Features close tolerance-machined, extremely durable motor components for extended use in industrial applications. **Model RG-383 features aluminum motor housing. Model RG-38ASLW features steel motor housing. Model RG-38CX features composite plastic housing.**



Model No.	Collet Size	Free Speed	Exhaust	Diameter	Length	Weight	Rec'd Hose Size	Air Inlet Thread	Avg. Air Consumption
RG-383					6-3/4"	1.3 lbs.			17.6 cfm
RG-38ASLW	1/4"	22000 rpm	Front	1-1/2"	6-25/32"	1.5 lbs.	3/8"	1/4"	15.9 cfm
RG-38CX					6-3/4"	1.3 lbs.			17.6 cfm



C-1025-0.125 1/8" Collet SN-17.5 Wrench  
C-1025-0.250 1/4" Collet SN-12.7 Wrench  
GG-43802 Collet Nut

## Michigan Pneumatic Model MP-70000 - Button Throttle Die Grinder - Side Exhaust

High speed die grinders for rapid metal removal or precise finishing. Versatile for driving carbide burrs or mounted points. Rugged, compact and lightweight for easy handling. Built-in regulator. **Parts are interchangeable with ARO 0-series short grinders.**

Collet Size.....	1/4"	Length.....	6-1/2"
Free Speed.....	18000 rpm	Weight.....	1.4 lbs.
Spindle Thread.....	3/8"-24	Air Inlet Thread.....	1/4"
Maximum HP.....	0.55	Avg. Air Consumption.....	14 cfm



MP-23000

C-1025-0.125 1/8" Collet SN-17.5 Wrench  
C-1025-0.250 1/4" Collet SN-12.7 Wrench  
GG-43802 Collet Nut

## Michigan Pneumatic Model MP-22000 - Button Throttle Die Grinder - Side Exhaust

Powerful die grinders designed for continuous service in industrial plants. Ideal for delicate finishing of aluminum, brass and plastic. **Parts are interchangeable with ARO 22-series short grinders. Button throttle model also available.**

Collet Size.....	1/4"	Length.....	7-3/4"
Free Speed.....	18000 rpm	Weight.....	1.9 lbs.
Spindle Thread.....	3/8"-24	Air Inlet Thread.....	1/4"
Maximum HP.....	0.7	Avg. Air Consumption.....	15.9 cfm



G-53801 Collet Body G-53850-0.125 1/8" Collet  
G-53802 Collet Nut G-53850-0.250 1/4" Collet

## Michigan Pneumatic Model MP-000-1 Die Grinder - Front Exhaust

Powerful, high speed baby grinder specially designed to drive carbide burrs and rotary files for effective metal removal or delicate finishing. Ideal for production work and cleaning castings in confined areas. Lever throttle permits varying speed for greater versatility. **Parts are interchangeable with Ingersoll-Rand 00 grinder.**

Collet Size.....	1/4"	Length.....	7-1/2"
Free Speed.....	20000 rpm	Weight.....	1.50 lbs.
Maximum HP.....	0.7	Air Inlet Thread.....	1/4"
Rec'd Hose Size.....	3/8"	Avg. Air Consumption.....	15.9 cfm

See pages 59-61 for grinder accessories.



# Rivet Shaver & Routers



## Hand-Held Routers



**DG20RTR**  
30000 rpm



**MP-GR2510**  
25000 rpm  
(aluminum model available)



**MP-GR1810A**  
18000 rpm  
(steel model available)



These hand-held "mini" base routers are ideal for trimming and cutting plastic parts, removing flashing from injection molded parts, wood, aluminum and fiberglass. Lightweight and easily maneuvered in tight areas. Perfect for one hand operation. **Model GR-2402 router guide not included. Please order separately.**

**GR-2402 Guide**

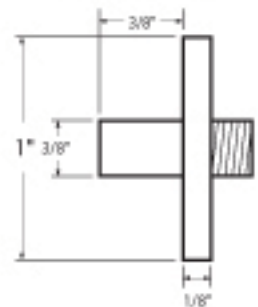

Model No.	Collet Size	Free Speed	Max. HP	Exhaust	Housing Material	Length	Weight
DG20RTR	1/4"	30000 rpm	0.60	Rear	Steel w/ Plastic Cover	9-13/16"	3.25 lbs.
MP-GR2510	1/4"	25000 rpm	1.00	Front	Steel	6-3/4"	3.25 lbs.
MP-GR2510A		25000 rpm			Aluminum		2.50 lbs.
MP-GR1810		18000 rpm			Steel		3.25 lbs.
MP-GR1810A		18000 rpm			Aluminum		2.50 lbs.

## Routers - with 6" Base



**MP-7000RTR**



**MP-2200RTR**



Model No.	Collet Size	Free Speed	Max. HP	Exhaust	Housing Material	Length	Weight	Base Diameter	Base Collar I.D.	Base Height
MP-7000RTR	1/4"	18000 rpm	0.55	Front	Aluminum	6-3/4"	2.75 lbs.	5"	1.375"	4-1/4"
MP-2200RTR			0.70			8"	4.25 lbs.	5-3/4"	1.750"	5"

## Michigan Pneumatic MP-8009RS

### Rivet Shaver Kit

Heavy-duty rivet shaver ideal for precision shaving of rivet heads. Designed so the skirt face is parallel to the cutter face. Spring loaded nose piece and stabilizer enables operator to feed cutter to the rivet faster and more accurately. **Includes seven skirts (as shown).**



Free Speed ..... 16000 rpm  
 Rec'd Hose Size ..... 3/8"  
 Length ..... 7-1/2"  
 Weight ..... 3.1 lbs.  
 Air Inlet Thread ..... 1/4"  
 Avg. Air Consumption ..... 4 cfm



See pages 59-61 for grinder accessories.

# Industrial Die Grinders



DG10G4



DG20L6

DG10-700-G4 Collet, 1/4" (DG10)  
DG20-700-G4 Collet, 1/4" (DG20)

## Michigan Pneumatic

### Standard Arbor Die Grinders - Rear Exhaust

DG Series for metal removal and precision die grinding. Features include: Standard and extended arbor models, safety-lock lever throttle, rear exhaust, lower sound level, one-piece collet, collet and threaded spindle models, high power to weight ratio, efficient and longer lasting, and an all steel housing with cushioning sleeve. Uses Ingersoll-Rand "New Generation" die grinder parts.

Model No.	Collet Size	Free Speed	Max. HP	Overall Length	Weight
DG10G4	1/4"	40000 rpm	0.33	6-3/16"	1 lb.
DG20G4	1/4"	30000 rpm	0.66	7-3/4"	2 lbs.
DG20L6	3/8"-24 thrd.	30000 rpm	0.66	7-3/4"	2 lbs.



EG10G4



EG20L6

DG10-700-G4 Collet, 1/4" (EG10)  
DG20-700-G4 Collet, 1/4" (EG20)

## Michigan Pneumatic

### Extended Arbor Die Grinders - Rear Exhaust

EG Series for finishing and polishing applications, metal removal and precision die grinding. Features include: OSHA approved, extended arbor models for greater versatility, safety-lock lever throttle, rear exhaust, lower sound level, one-piece collet, collet and threaded spindle models, unusually high power and speed, and an all steel housing with cushioning sleeve. Uses Ingersoll-Rand "New Generation" die grinder parts.

Model No.	Collet Size	Free Speed	Max. HP	Overall Length	Weight
EG10G4	1/4"	40000 rpm	0.33	9-11/16"	1.5 lbs.
EG20G4	1/4"	30000 rpm	0.66	12-3/4"	2.5 lbs.
EG20L6	3/8"-24 thrd.	30000 rpm	0.66	12-3/4"	2.5 lbs.



MP-9113A-14

C-1023N Collet Nut  
C-1028-0.250 Collet Insert, 1/4"  
C-1028-0.375 Collet Insert, 3/8"  
C-1023A-0.250 Collet Chuck Assembly, 1/4"  
C-1023A-0.375 Collet Chuck Assembly, 3/8"  
G-3327 Wrench  
G-3858 Wrench

## Michigan Pneumatic

### Standard Arbor Die Grinders - Front Exhaust

Uses mounted stones, wire brushes or carbide burs. Ideal for use in foundries, welding and fabrications shops, shipyards, rail car repair and many other industrial facilities.

Model No.	Collet Size	Free Speed	Housing	Overall Length	Weight
MP-9113-14	1/4"	25000 rpm	Steel	6-1/4"	2.25 lbs.
MP-9113-38	3/8"		Steel		2.25 lbs.
MP-9113A-14	1/4"		Aluminum		1.50 lbs.
MP-9113A-38	3/8"		Aluminum		1.50 lbs.

Maximum HP ..... 1.00 Air Inlet Thread ..... 1/4" NPT  
Rec'd Hose Size ..... 3/8" Avg. Air Consumption ..... 11.9 cfm



MP-9113E-38

C-1023N Collet Nut  
C-1028-0.250 Collet Insert, 1/4"  
C-1028-0.375 Collet Insert, 3/8"  
C-1023A-0.250 Collet Chuck Assembly, 1/4"  
C-1023A-0.375 Collet Chuck Assembly, 3/8"  
G-3327 Wrench  
G-3858 Wrench

## Michigan Pneumatic

### Extended Arbor Die Grinders - Side Exhaust

Uses mounted stones, wire brushes or carbide burs. Ideal for use in foundries, welding and fabrications shops, shipyards, rail car repair and many other industrial facilities.

Model No.	Collet Size	Free Speed	Housing	Overall Length	Weight
MP-9113E-14	1/4"	25000 rpm	Steel	11-1/16"	3.30 lbs.
MP-9113E-38	3/8"		Steel		3.30 lbs.
MP-9113AE-14	1/4"		Aluminum		2.63 lbs.
MP-9113AE-38	3/8"		Aluminum		2.63 lbs.

Maximum HP ..... 1.00 Air Inlet Thread ..... 1/4" NPT  
Rec'd Hose Size ..... 3/8" Avg. Air Consumption ..... 11.9 cfm



# Collet Adapters & Extensions



## Collet Mount Adapters & Extensions

### 1/4" Collet Mount

Model No.	Hole Dia.	Wheel Width	Wheel Dia.	Screw Dia.	Length
AE-105A	3/8"	1/64" - 9/16"	3"	1"	2-1/2"
AE-106-1A		1/4" - 3/8"	3"	1"	2-1/8"
AE-124A		1/64" - 3/4"	3"	1"	2-5/8"
AE-126A		1/16" - 1/4"	2"	5/8"	2-1/8"
AE-127A		1/16" - 1/4"	3"	1"	2-13/16"



### 3/8" Collet Mount

Model No.	Hole Dia.	Wheel Width	Wheel Dia.	Screw Dia.	Length
AE-140A	3/8"	1/64" - 1/4"	3"	1"	2-1/2"
AE-141A	3/8"	1/16" - 3/4"	3"	1"	3"
AE-150A	3/8"	1/2"	3"	1"	2-5/8"
AE-226A	3/8"	1/64" - 1/2"	4"	1-1/4"	2-5/8"
AE-229A-1	1/2"	1/64" - 1/4"	4"	1-1/4"	2-5/8"



### 3/8" Collet Mount Cone and Plug Wheel

Model No.	Thread	Wheel Dia.	Length
AE-139	3/8"-24	3"	2-5/32"
AE-148	5/8"-11		2-5/32"
AE-206	5/8"-11		2-3/8"



### 1/4" Collet Mount Cone and Plug Wheel

Model No.	Thread	Wheel Dia.	Length
AE-109	5/8"-11	3"	2-5/32"
AE-123	3/8"-24		2-5/32"



## Spindle Mount Adapters & Extensions

### 3/8"-24 Thread Mount

Model No.	Wheel I.D.	Wheel Width	Wheel Dia.	Thread	Length
AE-103A	3/8"	1/2"	3"	3/8"-24	2-1/2"
AE-115A		3/4"	3"		2-3/4"
AE-125A		3/4"	3"		2-5/8"
AE-175A		1/2"	3"		1-13/16"
AE-177A		5/8"	2"		1-15/16"



### Thread Mount Cone and Plug Wheel

Model No.	Int. Thread	Ext. Thread	Wheel Size	Length
AE-107-1	3/8"-24	5/8"-11	3"	2-1/8"
AE-107-2	1/2"-13	5/8"-11		2-1/8"
AE-107-3	3/8"-24	1/2"-20		2-1/8"
AE-118	3/8"-24	3/8"-24		2-1/8"
AE-122	3/8"-24	5/8"-11		15/16"
AE-131	3/8"-24	5/8"-11		2"
AE-176	3/8"-24	3/8"-24		13/16"
AE-182	3/8"-24	3/8"-24		3-5/16"



### 5/8"-11 Thread Mount

Model No.	Int. Thread	Ext. Thread	Wheel Size	Length
AE-211	5/8"-11 x 3/4"	5/8"-11	1-3/16"	4-1/4"
AE-212	5/8"-11 x 3-3/4"			7-1/4"



See pages 60-61 & 72-73 for additional grinder accessories.

# Collet Assemblies



## Collet Chuck Assemblies

Assemblies for 1/4", 3/8" or 1/2" shank mounted wheels or rotary files. Other collets, collet inserts and collet chuck nuts available.

Model No.	Replaces	Style	Capacity	Collet Nut	Length	Internal Thread
C-1001A C-1002A	ARO #30489-1 ARO #30854-3 MPT #43801-3	2-piece 3-piece 3-piece	1/4"	C-1001N C-1002N	1-7/8" 2-1/4"	3/8"-24
C-1007A	Dresser #849142	2-piece		C-1007N	2-3/16"	
C-1008A C-1009A	I-R #ROA-390-1/4" B&D #718504	2-piece	1/4"	C-1008N C-1009N	2-1/2" 1-5/8"	3/8"-24
C-1010A	Rotor #M827-1037 B&D #44014			C-1009N C-1010N	1-5/8" 2-1/2"	
C-1012A	Rockwell #Y-373 Rotor #M1086-1096	2-piece	1/4"	C-1012N C-1012N	1-9/16" 1-9/16"	3/8"-24
C-1013A C-1014A	Thor #70480 Thor #58980			C-1013N C-1014N	1-5/8" 2-3/16"	
C-1015A C-1016A	B&D #718590 3/8" cap. H.D. Grinders 1/2" cap.	2-piece 2-piece	3/8" 1/2"	C-1015N C-1045N	2-3/8" 2-11/16"	3/8"-24
C-1021A C-1023A-0.250 C-1023A-0.375	Erickson #A43807 Erickson #A34464 Erickson #A34464	4-piece 3-piece 3-piece	1/4" 1/4" 3/8"	C-1021N C-1023N C-1023N	1-3/4" 1-7/8" 1-7/8"	
C-1024A C-1032A C-1034A C-1035A	All H.D. Grinders ARO #41753-3 Erickson #A48590 Erickson #A16488/Double Angle	2-piece 3-piece 4-piece 3-piece	1/4"	C-1010N C-1032N C-1021N C-1035N	2-5/8" 2-1/4" 1-3/4" 2-1/16"	1/2"-13 3/8"-24 5/16"-24 3/8"-24
C-1036A C-1039A C-1049A-5/7/9	CP #C-069968 I-R #ROA-390-1/4" ARO #30385-1	2-piece		1/4"	C-1036N C-1039N C-1049N	3-1/2" 3-1/8" 5-7/7/9"
C-1056A C-1060A C-1070A	All H.D. Grinders CP #S-0066271Y B&D #44016	2-piece	1/4" 1/4" 3/8"	C-1039N C-1013N C-1070N	3-1/8" 2-3/16" 2-5/8"	1/2"-13 3/8"-24 3/8"-24
C-1079A-0.250 C-1079A-0.375			3-piece	1/4" 3/8"	C-1079N C-1079N	2-1/4"
C-1084A-0.250 C-1084A-0.375 C-1084A-0.500		3-piece	1/4" 3/8" 1/2"	C-1084N	2-1/2"	3/8"-24
C-1084A-1220-0.250 C-1084A-1220-0.375 C-1084A-1220-0.500			3-piece			
C-1104A C-1114A		2-piece	1/4" 3/8"	C-1107N	3-1/8" 3"	5/8"-11



### 3 & 4 Piece Assemblies



See pages 59, 61 & 72-73 for additional grinder accessories.



# Collet Inserts, Nuts & Adapters



## Collet Inserts

Replacement collet inserts for collet chuck assemblies.

Model No.	Replaces	Size
C-1025-0.125 C-1025-0.250	ARO #30847; MP #44850	1/8" 1/4"
C-1026-0.250	(not shown)	1/4"
C-1027-0.125 C-1027-0.1875 C-1027-0.250	ARO #31812; B&D #44001; CP #C110299Y; I-R #G120-700; Rotor #1233-1317	1/8" 3/16" 1/4"
C-1028-0.125 C-1028-0.1875 C-1028-0.250 C-1028-0.375	ARO #32988; CP #C119729Y; I-R #G140-700	1/8" 3/16" 1/4" 3/8"
C-1030-0.125 C-1030-0.250	B&D #71852 (not shown)	1/8" 1/4"
C-1033-0.125 C-1033-0.250	ARO #41750	1/8" 1/4"
C-1074-0.125 C-1074-0.250	CP #KF124524-C-138727; Rockwell #92233; UPI #1610 & #551	1/8" 1/4"
C-1093-0.125 C-1093-0.1875 C-1093-0.250	B&D #718524-3/16" & #718525-3/32"; Rockwell #1006647	1/8" 3/16" 1/4"



C-1025



C-1027



C-1028



C-1033



C-1074



C-1093

## Collet Chuck Nuts

Collet chuck nuts are available for all collet chucks.

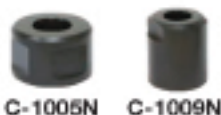

C-1005N C-1009N



C-1023N C-1062N



C-1091N TP10742

Model No.	Replaces
C-1005N	I-R #308-699; CP #KF-124525
C-1009N	B&D #718519; Master #550-35
C-1023N	ARO #44129; CP #C-122770; Dotco #2058
C-1062N	I-R #G140-699; ATS #C-1023N
C-1091N	Gardner-Denver #10549-525354
TP10742	Nitto Kohki MAS-20B

## Collet Adapters

These adapters permit the use of various mounted wheels or burs without changing collet chucks. All adapters are made with a shoulder to aid in removal with a minimum of inconvenience.

Model No.	Replaces
C-1040-0.0937	1/4" to 3/32"
C-1040-0.1562	1/4" to 5/32"
C-1040-0.125	1/4" to 1/8"
C-1040-0.1875	1/4" to 3/16"
C-1042	3/8" to 1/4"
C-1043	1/2" to 3/8"
C-1044	1/2" to 1/4"
C-1048	3/8" to 5/16"



C-1040



C-1042



C-1044

See pages 59-60 & 72-73 for additional grinder accessories.

# Disc Sanders



**NPK**



NSG-50A

NSG-100

Nippon Pneumatic **Model NSG-50A**  
**Model NSG-100**

## High-Speed Sander

Compact, perfectly balanced sanders for fine detail applications.

Model	NSG-50A	NSG-100
Capacity	2-1/4"	4"
Free Speed	15000 rpm	13000 rpm
Length	6-3/8"	6-3/16"
Weight	1.5 lbs.	2.0 lbs.
Air Inlet Thread	1/4"	1/4"
Avg. Air Consumption	9.2 cfm	14.1 cfm



Michigan Pneumatic **Model MP-2000X-F**

## High-Speed Sander

Lightweight tool is perfect for finishing flat or contoured surfaces, touch-up, feather-edging and production sanding. Rugged construction for years of carefree service. **Equipped with 3", 4-1/2", 5-1/2" fiber pads.**

5403	3" Fiber Pad	5404	4-1/2" Fiber Pad
5405P	5-1/2" Fiber Pad	110010	Disc Nut

Capacity	5"	Weight	1.75 lbs.
Free Speed	20000 rpm	Air Inlet Thread	1/4"
Length	5"	Avg. Air Consumption	4 cfm



Michigan Pneumatic **Model MP-727-ST**

## High-Speed Sander

Designed for finishing flat or contoured surfaces. Ideal for touch-up, feather-edging and production sanding.

822028	3" Fiber Pad
822029	4-1/2" Fiber Pad
822030	5-1/2" Fiber Pad
110010	Disc Nut

Capacity	5"	Weight	2.25 lbs.
Free Speed	18000 rpm	Air Inlet Thread	1/4"
Length	7-1/2"	Avg. Air Consumption	4 cfm



Michigan Pneumatic **Model MP-3814-DD**

## High-Speed Sander

See-through sander used in automotive repair shops when better visibility is required. Backing pad doubles as cooling system for sanding disc. Lightweight to reduce operator fatigue.

ACC-3812P	Backing Pad
ACC-3812A	36 Grit Sand Paper
ACC-3812B	60 Grit Sand Paper

Capacity	5"	Weight	3.65 lbs.
Free Speed	6000 rpm	Air Inlet Thread	1/4"
Length	8-1/4"	Avg. Air Consumption	5 cfm



National Detroit **Model DCQ**

## Disc Action Sander

Designed to speed production on light grinding and sanding to remove heavy grinder swirls. **Lower noise level, OSHA approved. Additional 4" and 5" pads also available. Please specify pad size.**

3021FP	4" Felt Pad
3055	5" Felt Pad

Capacity	4" or 5"	Weight	3.625 lbs.
Free Speed	12000 rpm	Air Inlet Thread	1/4"
Length	8"	Avg. Air Consumption	4 cfm



# Random Orbital Sanders



## Michigan Pneumatic Model MP-DA6-ST Random Orbital Sander

Ball bearing construction, balanced counterweights and a built-in speed regulator make this sander ideal for metal preparation.

SP-005 6" Vinyl Pad  
B-6201ZZ Pad Bearing

Capacity.....	6"	Weight.....	4 lbs.
Free Speed.....	10000 rpm	Air Inlet Thread.....	1/4"
Length.....	8-3/4"	Avg. Air Consumption.....	5 cfm



## National Detroit Model DA Dual Action Sander

Proven orbital action sander provides a smoother, scratch-free finish as the abrasives travel in a non-repeating path, reducing heat generation. Lightweight with built-in regulator. **Additional 3", 5" and 6" pads also available. Please specify pad size.**

4062-3 3" Vinyl Pad 4062-5 5" Vinyl Pad  
4062-6 6" Vinyl Pad

Capacity.....	3", 5" or 6"	Weight.....	4.125 lbs.
Free Speed.....	6000 rpm	Air Inlet Thread.....	1/4"
Length.....	8-1/4"	Avg. Air Consumption.....	11 cfm



## National Detroit Model DA-DE Dual Action Sander

Proven orbital action sander provides a smoother, scratch-free finish as the abrasives travel in a non-repeating path, reducing heat generation. Lightweight with built-in regulator. **Additional 5" and 6" pads also available. Please specify pad size.**

4162-5 5" Vinyl Pad with Dust Extraction Holes  
4162-6 6" Vinyl Pad with Dust Extraction Holes

Capacity.....	5" or 6"	Weight.....	4.125 lbs.
Free Speed.....	6000 rpm	Air Inlet Thread.....	1/4"
Length.....	8-1/4"	Avg. Air Consumption.....	11 cfm



## National Detroit Model DAQ Dual Action Sander

Proven orbital action sander provides a smoother, scratch-free finish as the abrasives travel in a non-repeating path, reducing heat generation. Lightweight with built-in regulator. **Lower noise level, OSHA approved. Additional 3", 5" and 6" pads also available. Please specify pad size.**

4062-3 3" Vinyl Pad 4062-5 5" Vinyl Pad  
4062-6 6" Vinyl Pad

Capacity.....	3", 5" or 6"	Weight.....	4.125 lbs.
Free Speed.....	6000 rpm	Air Inlet Thread.....	1/4"
Length.....	8-1/4"	Avg. Air Consumption.....	11 cfm



## National Detroit Model EZQ Dual Action Sander

Combines dual action sanding with features allowing the pad to operate flat on work surfaces. Exceptionally smooth operation for controlled stock removal. **Model EZQ-6DE with dust extraction system available. Additional 3", 4", 5" and 6" pads also available. Please specify pad size.**

4062-3 3" Vinyl Pad 4862-5 5" Vinyl Pad  
4062-4 4" Vinyl Pad 4862-6 6" Vinyl Pad

Capacity.....	3", 4", 5" or 6"	Weight.....	3.6 lbs.
Free Speed.....	10000 rpm	Air Inlet Thread.....	1/4"
Length.....	9-3/8"	Avg. Air Consumption.....	11 cfm

# Random Orbital Palm Sanders



## Michigan Pneumatic Model MP-844-ST

### Palm Sander - with Vacuum Pickup

Palm type sander features dust-free sanding for a cleaner work environment. Orbital action provides a smoother, finer finish for better results. Powerful, compact, lightweight, with low vibration action for operator comfort and higher productivity. Built-in adjustable speed regulator for versatility.

60334-6 6" Vinyl Pad with Dust Extraction Holes

Capacity.....6"	Weight.....3 lbs.
Free Speed.....10000 rpm	Air Inlet Thread.....1/4"
Height.....4"	Avg. Air Consumption.....6 cfm



## Michigan Pneumatic Model MP-3368-DD

### Palm Sander

Powerful palm sander designed to reduce heat generation on application material. Lightweight with built-in regulator.

4862-6 6" Vinyl Pad

Capacity.....6"	Weight.....1.56 lbs.
Free Speed.....12000 rpm	Air Inlet Thread.....1/4"
Height.....3-3/8"	Avg. Air Consumption.....11 cfm



## National Detroit Model PGU-DE

### Palm Sander - with Vacuum Pickup

Lightweight, powerful, quiet and rugged. Features integral dust extraction system, proven bearing design and interchangeable pads to fit any sanding application. **Model PGU without dust extraction system available.**

**Additional pads available. Please specify pad size.**

4862-5 5" Vinyl Pad      4162-5 5" Vinyl Pad w/Dust Extraction Holes  
4862-6 6" Vinyl Pad      4162-6 6" Vinyl Pad w/Dust Extraction Holes

Capacity.....5" or 6"	Weight.....2.1 lbs.
Free Speed.....12000 rpm	Air Inlet Thread.....1/4"
Height.....4-1/2"	Avg. Air Consumption.....11 cfm



## National Detroit Model PGSS

### Palm Sander

Random orbital sander designed for fine finish work. Ideal for sanding clear coat and lacquers. **Additional 3", 5" and 6" pads also available. Please specify pad size. Model PGSS-DE with dust extraction system available.**

4862-3 3" Vinyl Pad      4162-5 5" Vinyl Pad w/Dust Extraction Holes  
4862-5 5" Vinyl Pad      4162-6 6" Vinyl Pad w/Dust Extraction Holes  
4862-6 6" Vinyl Pad

Capacity.....3", 5" or 6"	Weight.....2.1 lbs.
Free Speed.....12000 rpm	Air Inlet Thread.....1/4"
Height.....4-3/4"	Avg. Air Consumption.....11 cfm



## National Detroit Model PG-8

### Palm Sander

One hand sander allows for better control on flat surfaces. Reduces "scallops" on wood and fiberglass due to uneven pressure applied to the tool. Heavy-duty construction for durability. **Model PG-8DE with dust extraction system available.**

4180 8" Vinyl Pad w/Dust Extraction Holes

Capacity.....8"	Weight.....3.1 lbs.
Free Speed.....8000 rpm	Air Inlet Thread.....1/4"
Height.....5"	Avg. Air Consumption.....12 cfm



# Gear Driven Sanders & Buffers



## National Detroit Model 9600

### Geared Sander

Capable of rough knock-down or fine feather edging. The driven gear "floats" on a cushioned mounting, providing smoother control with the power of a gear driven design. Model 9600DE with dust extraction system available. Additional 5" and 6" pads also available. Please specify pad size.

9450-5	5" Vinyl Pad	9677-5	5" Hook & Loop Pad with DE Holes
9460-6	6" Vinyl Pad	9677-6	6" Hook & Loop Pad with DE Holes

Capacity.....	5" or 6"	Weight.....	4.5 lbs.
Free Speed.....	9000 rpm	Air Inlet Thread.....	1/4"
Abrasive Area.....	28 sq. in.	Avg. Air Consumption.....	14 cfm



## National Detroit Model 9900

### Geared Buffer/Sander

Lightweight buffer/sander removes paint up to 3.5 times faster than other sanders. T-handle motor cover and soft grip handle provide ergonomic comfort.

9591	6" Buffering Pad
9980	6" Vinyl Pad

Capacity.....	6" Buffer/6" Pad	Weight.....	4.7 lbs.
Free Speed.....	9000 rpm	Air Inlet Thread.....	1/4"
Abrasive Area.....	28 sq. in.	Avg. Air Consumption.....	14 cfm



## National Detroit Model 9900DE

### Geared Buffer/Sander

Lightweight buffer/sander removes paint up to 3.5 times faster than other sanders. T-handle motor cover and soft grip handle provide ergonomic comfort.

9591	6" Buffering Pad
9980	6" Vinyl Pad

Capacity.....	6" Buffer/6" Pad	Weight.....	5 lbs.
Free Speed.....	9000 rpm	Air Inlet Thread.....	1/4"
Abrasive Area.....	28 sq. in.	Avg. Air Consumption.....	14 cfm



## National Detroit Model 900

### 8" Geared Sander

Gear driven sander moves with positive rotation and secondary oscillating action. Fast stock removal prevents normal grinder scratch patterns. Designed for applications between grinding and finish sanding. Features a built-in regulator.

4080VP	8" Vinyl Pad
--------	--------------

Capacity.....	8"	Weight.....	4.75 lbs.
Free Speed.....	9000 rpm	Air Inlet Thread.....	1/4"
Abrasive Area.....	50 sq. in.	Avg. Air Consumption.....	14 cfm



## National Detroit Model 900DE

### 8" Geared Sander

Gear driven sander moves with positive rotation and secondary oscillating action. Fast stock removal prevents normal grinder scratch patterns. Designed for applications between grinding and finish sanding. Features a built-in regulator.

4088	8" Vinyl Pad with Dust Extraction Holes
------	---

Capacity.....	8"	Weight.....	5 lbs.
Free Speed.....	9000 rpm	Air Inlet Thread.....	1/4"
Abrasive Area.....	50 sq. in.	Avg. Air Consumption.....	14 cfm

# Vertical Sanders & Buffer



## Michigan Pneumatic Model MP-1265-ST

### Vertical Sander

Features extra-heavy gearing for heavy-duty operation. Compact and lightweight design for hard to reach spots and reduced operator fatigue. Adjustable speed control allows delicate feather-edging to full speed sanding.

829040 Pad Nut 731247 Pad

Capacity .....	7"	Height .....	7-1/2"
Free Speed .....	4000 rpm	Weight .....	4.5 lbs.
Spindle Thread .....	5/8"-11	Air Inlet Thread .....	1/4"
Maximum HP .....	1.00	Avg. Air Consumption .....	9 cfm



## Michigan Pneumatic Model MP-B332

### Vertical Sander - with Rubber Pad

Heavy-duty tool for steady production. May be used for disc sanding, cup wire brushing and cup wheel grinding. Ideal for cutting high spots and smoothing flat surfaces. **Please specify lever or butterfly throttle. Model MP-B332WW with wire wheel available.**

R700-R 7" Rubber Backing Pad

Capacity .....	7" Pad	Length .....	8-3/4"
Free Speed .....	6000 rpm	Height .....	7-5/8"
Spindle Thread .....	5/8"-11	Weight .....	7.3 lbs.
Maximum HP .....	1.20	Air Inlet Thread .....	3/8"



## National Detroit Model XLB

### Buffer/Sander

Excels at both sanding and buffing. Double row head bearing design for long life. Features foam grip and T-handle for operator comfort. **Additional 3", 5" and 6" pads also available. Please specify pad size.**

4862-3 3" Vinyl Pad 4862-5 5" Vinyl Pad  
4862-6 6" Vinyl Pad

Capacity .....	3", 5" or 6"	Weight .....	3.3 lbs.
Free Speed .....	10000 rpm	Air Inlet Thread .....	1/4"
Abrasive Area .....	28 sq. in.	Avg. Air Consumption .....	13 cfm



## Michigan Pneumatic Model MP-6902K7-ST

### Stripping Tool Kit

Versatile tool used in the automotive industry. Excellent for cleaning welds, adhesives and rust off work surface.

SM-6902	Utility In-Line Driver	0511	11mm Brush (Fine)
SA-6902RW	Rubber Eraser	0711	11mm Brush (Coarse)
SA-6902WH	Adaptor (11mm)	0523	23mm Brush (Fine)
SA-6902RH	Adaptor (23mm)	0723	23mm Brush (Coarse)

#### MP-6902K7-ST Accessories (included)



Free Speed .....	3500 rpm	Rec'd Hose Size .....	3/8"
Length .....	12"	Air Inlet Thread .....	1/4"
Weight .....	3.2 lbs.	Avg. Air Consumption .....	4 cfm



# Belt Sanders



TA99155 Idler Pulley Assembly

## Michigan Pneumatic Model MP-10A-ST Belt Sander

Small, lightweight belt sander, ideal for all materials, eliminates filing. Goes deep into hard to reach places, corners and spherical surfaces.

61122 40 Grit Belt    61125 80 Grit Belt    61127 120 Grit Belt  
61124 60 Grit Belt    61126 100 Grit Belt

Belt Size	3/8" x 13"	Length (max.)	10-7/16"
Free Speed	16000 rpm	Weight	1.7 lbs.
Height	2"	Air Inlet Thread	1/4"
Maximum HP	0.4	Avg. Air Consumption	14 cfm



TA90514 Idler Pulley Assembly

## Michigan Pneumatic Model MP-20S-ST Belt Sander

Small, lightweight air sander will sand all jobs, all materials with amazing speed and ease. No surface escapes its all-surface capability. Levels and contours, even in corners. Adjustable handle rotates 360°. Change belts in seconds.

60129 40 Grit Belt    60132 80 Grit Belt    60134 120 Grit Belt  
60131 60 Grit Belt    60133 100 Grit Belt

Belt Size	3/4" x 20-1/2"	Length (max.)	18-1/2"
Free Speed	16000 rpm	Weight	3.1 lbs.
Height	2-23/64"	Air Inlet Thread	1/4"
Maximum HP	0.6	Avg. Air Consumption	18 cfm



TA91522 Idler Pulley Assembly

## Michigan Pneumatic Model MP-30S-ST Belt Sander

The most efficient adjustable belt sander ever developed, with a new, silent motor. Sands all materials with speed and ease. Levels and contours, even in corners. Maximum efficiency without operator fatigue.

TP04084-0 60 Grit Belt    TP04086-0 100 Grit Belt  
TP04085-0 80 Grit Belt

Belt Size	1-3/16" x 21"	Length (max.)	19-1/4"
Free Speed	12000 rpm	Weight	4.9 lbs.
Height	4-1/8"	Air Inlet Thread	3/8"
Maximum HP	0.7	Avg. Air Consumption	24 cfm



## Michigan Pneumatic Model MP-6201K-DD Belt Sander Kit

Lightweight belt sander levels and contours most surfaces, even in corners. Includes 6 interchangeable contact arms and assorted sanding belts with plastic case.

Belt Size	1/4" - 1" x 18"	Length (max.)	15.4"
Free Speed	18000 rpm	Weight	2.9 lbs.
Height	2-11/32"	Air Inlet Thread	1/4"
Maximum HP	0.6	Avg. Air Consumption	16 cfm



## Michigan Pneumatic Model MP-MVM3562 Belt Sander

Comfortable and well balanced. Features easy fingertip tracking and belt changing. Excellent power and speed for any belt sanding operation. Ideal for working around water and in heavy dust environments. Uses standard 3" x 21" belts, 100 grit or finer. Includes dust extraction bag.

Belt Size	3" x 21"	Length (max.)	13"
Free Speed	2600 rpm	Weight	9.25 lbs.
Height	8"	Air Inlet Thread	1/4"
Maximum HP	1.25	Avg. Air Consumption	29 cfm

# Belt & Pad Sanders



TA99155 Idler Pulley Assembly

## Nitto Kohki Model B-10B

### Belt Sander

Small, lightweight belt sander, ideal for all materials, eliminates filing. Goes deep into hard to reach places, corners and spherical surfaces.

61122 40 Grit Belt    61125 80 Grit Belt    61127 120 Grit Belt  
61124 60 Grit Belt    61126 100 Grit Belt

Belt Size .....	3/8" x 13"	Length (max.) .....	10-7/16"
Free Speed .....	16000 rpm	Weight .....	1.7 lbs.
Height .....	2"	Air Inlet Thread .....	1/4"
Maximum HP .....	0.4	Avg. Air Consumption .....	14 cfm



TA90514 Idler Pulley Assembly

## Nitto Kohki Model B-20C

### Belt Sander

Small, lightweight air sander will sand all jobs, all materials with amazing speed and ease. No surface escapes its all-surface capability. Levels and contours, even in corners. Adjustable handle rotates 360°. Change belts in seconds.

60129 40 Grit Belt    60132 80 Grit Belt    60134 120 Grit Belt  
60131 60 Grit Belt    60133 100 Grit Belt

Belt Size .....	3/4" x 20-1/2"	Length (max.) .....	18-1/2"
Free Speed .....	16000 rpm	Weight .....	3.1 lbs.
Height .....	2-23/64"	Air Inlet Thread .....	1/4"
Maximum HP .....	0.6	Avg. Air Consumption .....	18 cfm



TA91522 Idler Pulley Assembly

## Nitto Kohki Model B-30A

### Belt Sander

The most efficient adjustable belt sander ever developed, with a new, silent motor. Sands all materials with speed and ease. Levels and contours, even in corners. Maximum efficiency without operator fatigue.

TP04084-0 60 Grit Belt    TP04086-0 100 Grit Belt  
TP04085-0 80 Grit Belt

Belt Size .....	1-3/16" x 21"	Length (max.) .....	19-1/4"
Free Speed .....	12000 rpm	Weight .....	4.9 lbs.
Height .....	4-1/8"	Air Inlet Thread .....	1/4"
Maximum HP .....	0.7	Avg. Air Consumption .....	24 cfm



## Nitto Kohki Model FS-50A

### Free Sander

Compact and lightweight with low air consumption for big jobs and tight spots. Rugged construction for continuous operation. Perfect for surface finishing wood and thin plates or de-burring plastic. Features quick change paper clips for easy mounting. **Low vibration motor reduces operator fatigue.**

Capacity .....	2-3/4" x 4-1/2"	Weight .....	1.1 lbs.
Free Speed .....	15000 rpm	Air Inlet Thread .....	1/4"
Abrasive Area .....	12.5 sq. in.	Avg. Air Consumption .....	4.9 cfm



## Nitto Kohki Model FS-100C

### Free Sander

Compact and lightweight with low air consumption for big jobs and tight spots. Rugged construction for continuous operation. Perfect for surface finishing wood and thin plates or de-burring plastic. Features quick change paper clips for easy mounting. **Low vibration motor reduces operator fatigue.**

Capacity .....	4-1/2" x 5-1/2"	Weight .....	1.1 lbs.
Free Speed .....	20000 rpm	Air Inlet Thread .....	1/4"
Abrasive Area .....	24 sq. in.	Avg. Air Consumption .....	7.1 cfm



# Orbital Pad Sanders



## Michigan Pneumatic Model MP-865-ST Orbital Action Sander/Jitterbug

Heavy-duty sander is ideal for body and paint shops. 3/16" orbital stroke provides a swirl-free finish. Powerful, fully enclosed motor. Balanced for vibration-free performance. Ideal for wet and dry sanding.

Capacity.....	3-2/3" x 9"	Weight.....	4.5 lbs.
Free Speed.....	6500 rpm	Air Inlet Thread.....	1/4"
Abrasive Area.....	25 sq. in.	Avg. Air Consumption.....	7 cfm

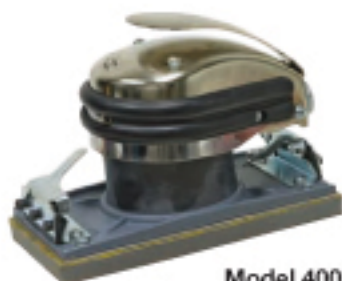

Model 400

## National Detroit Model 150 & Model 400 Orbital Action Sanders

Powerful, versatile, dependable, quiet sanders work on the principle of circular movement, with a 3/16" orbital stroke. Ideal for metal or wood finishing jobs. Great for hard to reach areas.

113 Neoprene Pad (150) DP1084 Neoprene Pad (400)

Model	150	400
Capacity	3" x 8"	3-2/3" x 9"
Free Speed	4000 - 6000 rpm	4000 - 6000 rpm
Abrasive Area	18 sq. in.	25 sq. in.
Weight	3.875	4.5
Air Inlet Thread	1/4"	1/4"
Avg. Air Consumption	7 cfm	7 cfm



## National Detroit Model 2200 Orbital Pad Sander

Aggressive, yet controllable sander perfect for today's sanding needs. Non-marring pad and quiet motor round out the features.

8890RP Rubber Pad  
8891RP Rubber Pad, textured

Capacity.....	2-3/4" x 8"	Weight.....	4.7 lbs.
Free Speed.....	6000 rpm	Air Inlet Thread.....	1/4"
Abrasive Area.....	22 sq. in.	Avg. Air Consumption.....	11 cfm



## National Detroit Model 2200DE Orbital Pad Sander - with Vacuum Pickup

Dust extraction version of the 2200 designed to remove contaminants from the work surface. Features a non-marring pad.

8890RP Rubber Pad  
8891RP Rubber Pad, textured

Capacity.....	2-3/4" x 8"	Weight.....	4.8 lbs.
Free Speed.....	6000 rpm	Air Inlet Thread.....	1/4"
Abrasive Area.....	22 sq. in.	Avg. Air Consumption.....	11 cfm



## National Detroit Model FB-8 Orbital Pad Sander

Rapid material knock-down achieved using positive thrust support from the motor. Superb counter-balancing insures minimal vibration reducing operator fatigue.

4191RP Rubber Pad

Capacity.....	2-3/4" x 16"	Weight.....	5.5 lbs.
Free Speed.....	6000 rpm	Air Inlet Thread.....	1/4"
Abrasive Area.....	44 sq. in.	Avg. Air Consumption.....	11 cfm

# Straight-Line Sanders



## National Detroit Model 600 Straight-Line Sander

Single pad sander will boost production and provide a better finish. Rapid stock removal with built-in water spray attachment. Paper change is simple and quick. Ideal for wet sanding. **OSHA approved.**

6150 Molded Rubber Pad

Capacity .....	3-2/3" x 9"	Weight .....	5.375 lbs.
Free Speed .....	3200 rpm	Air Inlet Thread .....	1/8"
Abrasive Area .....	25 sq. in.	Avg. Air Consumption .....	7 cfm



## National Detroit Model 300 Two-Pad Straight-Line Sander

Double pad sander will boost production and provide the best finish possible. Rapid stock removal with built-in water spray attachment. Ideal for wet sanding. Six different pads available, please specify. Meets OSHA noise level standards. **Price includes shoes and pads.**

DP1086 Rubber Pad

Capacity .....	3-2/3" x 9"	Weight .....	6 lbs.
Free Speed .....	2250 rpm	Air Inlet Thread .....	1/4"
Abrasive Area .....	50 sq. in.	Avg. Air Consumption .....	7 cfm



## National Detroit Model 1100 Straight-Line Sander

Compact straight-line sander designed for fine finish work. Polymer pad shoe won't damage work surface.

8890RP Rubber Pad

8891RP Rubber Pad, textured

Capacity .....	2-3/4" x 8"	Weight .....	4.75 lbs.
Free Speed .....	6000 rpm	Air Inlet Thread .....	1/4"
Abrasive Area .....	22 sq. in.	Avg. Air Consumption .....	11 cfm



## National Detroit Model 1100DE Straight-Line Sander

Straight-line powerhouse with dust extraction system. Features non-marring polymer pad.

8890RP Rubber Pad

8891RP Rubber Pad, textured

Capacity .....	2-3/4" x 8"	Weight .....	4.8 lbs.
Free Speed .....	6000 rpm	Air Inlet Thread .....	1/4"
Abrasive Area .....	22 sq. in.	Avg. Air Consumption .....	11 cfm



## Michigan Pneumatic Model MP-0065-ST Straight-Line Sander

The "President" features double acting pistons and a four cylinder driving system. As the dual pistons constantly work in alternating opposition to one another, there is no dead center, providing unparalleled power on the job and fatigue-free operation.

Capacity .....	2-3/4" x 17-1/4"	Weight .....	6.5 lbs.
Free Speed .....	3300 rpm	Air Inlet Thread .....	1/4"
Abrasive Area .....	40 sq. in.	Avg. Air Consumption .....	6 cfm



# Extended Arbor Grinders



Nippon Pneumatic

## Straight Collet Grinders

Lightweight aluminum grinder with narrow housing allows operator access to difficult areas. Ideal for one hand operation. Integrated safety throttle mechanism assures operator safety. **Not equipped with wheel guard.** 6mm collet grinders also available.

# NPK®

- 15003420 Collet Nut
- 15015755 1/4" Collet Assembly (3/8"-16)
- 15015752 6mm Collet Body (3/8"-16)
- 15015753 1/4" Collet Body (3/8"-16)
- SN-17 Open End Wrench
- TSP-28 Spanner Wrench



NHG-65LK-20



NHG-65KLV-20



NHG-65LKLW-20

Model No.	Collet Size	Free Speed	Spindle Thread	Throttle Style	Maximum HP	Length	Weight	Rec'd Hose Size	Air Inlet Thread	Avg. Air Consumption
NHG-65K-20	1/4"	18000 rpm	3/8"-16	Safety Roll	1.0	12-3/16"	2.9 lbs.	3/8"	1/4"	19.4 cfm
NHG-65KLV-20				Safety Lever		13-5/16"	2.9 lbs.			
NHG-65LK-20				Safety Roll		20-1/16"	3.5 lbs.			
NHG-65LKLW-20				Safety Lever		21-3/16"	3.5 lbs.			

Nippon Pneumatic

## Straight Wheel Grinders

Ideal for boiler tube applications and grinding or deburring deep, intricate castings. Light, aluminum housing and safety throttle allows for safe, maneuverable grinding. Removes metal fast. **NHG-65D Series equipped with wheel guard.** Wheel not included.

# NPK®

- 28100387 Hex Nut (3/8"-16)
- 28100380 Hex Nut (3/8"-16)
- 28100390 Hex Nut (3/8"-24)
- 28100382 Hex Nut (3/8"-24)
- 15003420 Collet Nut
- 15000050 1/4" Collet Body (3/8"-24)
- TSP-28 Spanner Wrench



NHG-65LDLW



NHG-65ALW



NHG-65LAULW

Model No.	Wheel Capacity	Free Speed	Spindle Thread	Throttle Style	Maximum HP	Length	Weight	Rec'd Hose Size	Air Inlet Thread	Avg. Air Consumption
NHG-65D	2-1/2" x 1/2" x 3/8"	14600 rpm	3/8"-16	Safety Roll	1.0	12-3/16"	2.9 lbs.	3/8"	1/4"	19.4 cfm
NHG-65DLW				Safety Lever		13-5/16"	2.9 lbs.			
NHG-65LD				Safety Roll		20-1/16"	3.5 lbs.			
NHG-65LDLW				Safety Lever		21-3/16"	3.5 lbs.			
NHG-65ALW	2" x 1/2" x 3/8"	18000 rpm	3/8"-16	Safety Lever	1.0	11-21/32"	2.4 lbs.	3/8"	1/4"	19.4 cfm
NHG-65LAULW						19-17/32"	3.1 lbs.			

See pages 59-61 & 72-73 for grinder accessories.

# Wheel Grinders & Belt Attachments



Michigan Pneumatic Models MP-1012-CWHL, MP1012 and MP-1012-BGA12/MP-1012-BGA21

## Straight and Cone Wheel Grinders



The **MP-1012-CWHL** is a small, lightweight, easy to handle grinder. Designed for production grinding of small concave surfaces, especially in close quarters. Ideally used for rotary file burring and for small cone wheel grinding. **1/4" collets available.**

The **MP-1012** is specially designed for radial wheel grinding projects where lightweight and small size are important. Desirable tool for production grinding of small concave surfaces, deep crevices and pockets. **1/4" collets available.**

**MP-1012-BGA12** or **MP-1012-BGA21** grinder with the Port-A-Belt attachment effectively reduces production costs. The Port-A-Belt conforms to convex or concave surfaces and irregular shapes, which results in more uniform contours. Cool running and greater surface contact allows for a finer finish. **Extra belts available. Two models available. See chart below.**

Specifications	MP-1012-CWHL	MP-1012	MP-1012-BGA Series
Capacity	Cone Wheel	3" x 1/2" (flat wheel)	12" x 1" (belt)
Free Speed	12000 rpm	12000 rpm	12000 rpm
Spindle Thread	3/8"-24	3/8"-24	3/8"-24
Maximum HP	1.00	1.00	1.00
Length	11-1/2"	11-1/2"	14"
Weight	3.8lbs.	4.4 lbs.	5.7 lbs.
Air Inlet Thread	1/4"	1/4"	1/4"
Avg. Air Consumption	20 cfm	20 cfm	20 cfm

## Port-A-Belt Grinding Attachments

Contact Wheel (idler)



BGA12 and BGA24 Series

Ideal for sanding concave or convex surfaces. Available with rubber contact wheel on spindle or on idler. Please specify tool model number or mounting clamp bore diameter.

Accessory for MPT Tool Model	Order Attachment Part No.	Idler Contact Wheel Dia.	Contact Wheel Part No.	Belt Size L x W	Rec'd Speed
MP-79000	BGA12-1.250	2"	B8661	12" x 1"	18000 rpm
MP-1012	BGA12-1.560	2"	B8661	12" x 1"	12000 rpm
NHG-150	BGA24-2.250	4"	G8629	20" x 2"	6000 rpm

## Extra Belts & Contact Wheels

**B8661** Contact Wheel  
**G8629** Contact Wheel  
**B8459** Contact Wheel  
**G8440** Contact Wheel

Part No.	Belt Size L x W	Grit
60145	12" x 1"	80
60146		100
60147		120
60608A	20" x 2"	80
60609A		100
60610A		120



Contact Wheel (spindle)

BGA21 and BGA42 Series

Accessory for MPT Tool Model	Order Attachment Part No.	Spindle Contact Wheel Dia.	Contact Wheel Part No.	Belt Size L x W	Rec'd Speed
MP-79000	BGA21-1.250	2"	B8459	12" x 1"	18000 rpm
MP-1012	BGA21-1.560	2"	B8459	12" x 1"	12000 rpm
NHG-150	BGA42-2.250	4"	G8440	20" x 2"	6000 rpm

See pages 59-61 & 72-73 for grinder accessories.



# Wheel Grinders - Industrial

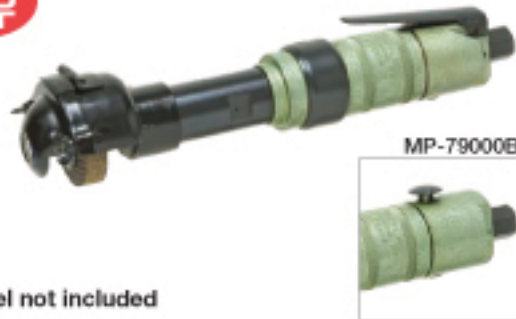

Wheel not included

Michigan Pneumatic **Model MP-79000B** - Button Throttle  
**Model MP-79000L** - Lever Throttle

## 2" Straight Grinder - with Guard

Powerful, lightweight grinder designed to ensure easy handling. Ideal for grinding small radius concave surfaces and grinding in confined spaces. Built-in speed regulator is standard. 1/4" collets and belt grinding attachments available. Parts are interchangeable with the ARO 22-Series 2" grinder.

Wheel Capacity .....	2" x 1/2"	Length.....	12"
Free Speed .....	18000 rpm	Weight.....	3.25 lbs.
Spindle Thread .....	3/8"-24	Air Inlet Thread .....	1/4"
Maximum HP .....	0.7	Avg. Air Consumption .....	15.9 cfm



Wheel not included

Michigan Pneumatic **Model MP-9113A-EW**

## 3" Straight Grinder - with Guard

Designed for casting cleanup, smoothing welds and burr removal in fabrication shops and shipyards. Features a lightweight aluminum body and side exhaust.

Wheel Capacity .....	3" x 1/2"	Length.....	13-1/2"
Free Speed .....	18000 rpm	Weight.....	3.00 lbs.
Spindle Thread .....	3/4"-24	Air Inlet Thread .....	1/4"
Maximum HP .....	1.00	Avg. Air Consumption .....	11.9 cfm



Wheel not included

Michigan Pneumatic **Model MP-9115-EW**

## 3" Straight Grinder - with Guard

Ideal for use in shipyards, refineries and fabrication shops. Features safety lever throttle, side exhaust and steel housing.

Wheel Capacity .....	3" x 1/2"	Length.....	13-1/2"
Free Speed .....	18000 rpm	Weight.....	4.00 lbs.
Spindle Thread .....	3/8"-24	Air Inlet Thread .....	1/4"
Maximum HP .....	1.00	Avg. Air Consumption .....	11.9 cfm



Cone Wheel not included

Michigan Pneumatic **Model MP-2511**

## Cone Wheel Grinder

Designed for production grinding of small concave surfaces, especially in close quarters. Ideally used for rotary file burring and for small cone wheel grinding.

Wheel Capacity .....	Cone Wheel	Length.....	18"
Speed.....	12000 rpm	Weight.....	6.75 lbs.
Spindle Thread .....	5/8"-11	Air Inlet Thread .....	1/2"
Maximum HP .....	1.50	Avg. Air Consumption .....	32 cfm



Wheel not included

Michigan Pneumatic **Model MP-2**

## 5" Straight Grinder - with Guard

Best suited for cleaning castings, removing fins, grinding welds, and buffing sheet metal. Designed to be light and sturdy for effective metal removal. Built-in lubricator and automatic governor provide lifelong dependability.

Wheel Capacity .....	5" x 3/4"	Length.....	17"
Free Speed .....	7500 rpm	Weight.....	7.25 lbs.
Spindle Thread .....	1/2"-13	Air Inlet Thread .....	3/8"
Maximum HP .....	1.50	Avg. Air Consumption .....	32 cfm

# Straight Wheel Grinders - Industrial



**NPK**



NHG-100A



Wheel not included

Nippon Pneumatic **Model NHG-100ALW - Safety Lever Throttle**  
**Model NHG-100A - Safety Roll Throttle**

## 4" Straight Grinder - with Guard

High speed straight grinder designed for continuous duty production work in grinding, wire brushing and polishing. Powerful, with a quick acting throttle to provide balanced, easy handling for efficient metal removal. For all industrial applications in foundries and shipyards.

Wheel Capacity .....	4" x 5/8"	Length.....	15-1/2"
Free Speed .....	9500 rpm	Weight.....	5.25 lbs.
Spindle Thread .....	1/2"-13	Air Inlet Thread .....	3/8"
Maximum HP .....	1.00	Avg. Air Consumption .....	23 cfm

**NPK**



NHG-125



Wheel not included

Nippon Pneumatic **Model NHG-125LW - Safety Lever Throttle**  
**Model NHG-125 - Safety Roll Throttle**

## 5" Straight Grinder - with Guard

Best suited for cleaning castings, removing fins, grinding welds, and buffing sheet metal. Designed to be light and sturdy for effective metal removal. Built-in lubricator and automatic governor provide lifelong dependability.

Wheel Capacity .....	5" x 3/4"	Length.....	17-13/16"
Free Speed .....	7500 rpm	Weight.....	7.0 lbs.
Spindle Thread .....	1/2"-12	Air Inlet Thread .....	3/8"
Maximum HP .....	1.10	Avg. Air Consumption .....	32 cfm

**NPK**



NHG-150



Wheel not included

Nippon Pneumatic **Model NHG-150LW - Safety Lever Throttle**  
**Model NHG-150 - Safety Roll Throttle**

## 6" Straight Grinder - with Guard

Powerful grinders for use with resinoid wheels. Designed to be lightweight for easier handling, and powerful for the heaviest work. Speed regulator provides constant speed according to wheel diameter. Perfect for all industrial applications.

Wheel Capacity .....	6" x 1"	Length.....	17-1/4"
Free Speed .....	6200 rpm	Weight.....	9.5 lbs.
Spindle Thread .....	5/8"-11	Air Inlet Thread .....	3/8"
Maximum HP .....	2.00	Avg. Air Consumption .....	39 cfm

Michigan Pneumatic **Model MP-5666HS**

## 6" Straight Grinder - with Guard

Heavy-duty grinder for cleaning castings, smoothing, finishing, snagging welds, removing scale, rust and weld splatter. Used for a variety of applications in fabrication shops, refineries, foundries, shipyards and steel mills. Features a high force, corrosion resistant governor to retain optimum grinding efficiency. **Model MP-5648HS 4500 rpm, 8" horizontal grinder also available.**

Speed.....	6000 rpm	Length.....	20-1/8"
Wheel Capacity .....	6" x 1"	Weight.....	10.5 lbs.
Spindle Thread .....	5/8"-11	Air Inlet Thread .....	1/2"
Maximum HP .....	3.00	Avg. Air Consumption .....	45 cfm

Wheel not included

Michigan Pneumatic **Model MP-6648HS**

## 8" Straight Grinder - with Guard

Heavy-duty grinder for cleaning castings, smoothing, finishing, snagging welds, removing scale, rust and weld splatter. Used for a variety of applications in fabrication shops, refineries, foundries, shipyards and steel mills. Features an aircraft grade aluminum housing. **Model MP-6666HS 6000 rpm, 6" horizontal grinder also available.**

Speed.....	4500 rpm	Length.....	20-7/8"
Wheel Capacity .....	8" x 1"	Weight.....	12.5 lbs.
Spindle Thread .....	5/8"-11	Air Inlet Thread .....	1/2"
Maximum HP .....	4.00	Avg. Air Consumption .....	50 cfm

Wheel not included



# Right Angle Grinders



3-1/4"



Wheel not included

## Michigan Pneumatic Model MP-250L-ST

### 4" Angle Grinder - with Guard

Rugged, lightweight angle grinder for many applications. Removes rust and paint fast. Great for dressing up welds and grinding complex shapes. Features safety lever throttle and governor. Uses 4" x 5/8" hole, type 27, depressed center grinding wheels.

Capacity .....	4"	Length .....	9"
Free Speed .....	12000 rpm	Weight .....	4.5 lbs.
Spindle Thread .....	3/8"-24	Air Inlet Thread .....	1/4"
Maximum HP .....	1.00	Avg. Air Consumption .....	10 cfm



3-1/4"



Wheel not included

## Michigan Pneumatic Model MP-1FB

### 4" Angle Grinder - with Guard

Small, rugged, versatile angle grinder will do a multitude of jobs with minimum operator fatigue. Heavy enough to remain stable, yet light enough to be maneuvered easily around complex shapes. 1/4" collets available for collet grinding. Features safety lever throttle.

Capacity .....	4"	Length .....	9"
Free Speed .....	12700 rpm	Weight .....	3.5 lbs.
Spindle Thread .....	3/8"-24	Air Inlet Thread .....	1/4"
Maximum HP .....	1.00	Avg. Air Consumption .....	24 cfm



2-1/2"



Wheel not included

## Michigan Pneumatic Model MP-3040

### 4" Angle Grinder - with Guard

Ideal for industrial applications including welding shops, foundries, fabrication plants, steel mills and shipyards. Model MP-3040A with aluminum housing and MP-3040-E4 extended angle grinder also available.

Capacity .....	4"	Length .....	8"
Free Speed .....	13500 rpm	Weight .....	3.125 lbs.
Spindle Thread .....	3/8"-24	Air Inlet Thread .....	1/4"
Maximum HP .....	1.00	Avg. Air Consumption .....	11.9 cfm



2-1/2"



Wheel not included

## Michigan Pneumatic Model MP-3040-E4

### 4" Angle Grinder - with Guard

Rugged 1HP motor angle grinder designed for cleaning, deburring, smoothing and blending. Ideal for foundries, shipyards and fabrication shops. Features adjustable side exhaust. Model MP-3040A-E4 with aluminum motor housing available.

Capacity .....	4"	Length .....	10"
Free Speed .....	13500 rpm	Weight .....	3.5 lbs.
Spindle Thread .....	3/8"-24	Air Inlet Thread .....	1/4"
Maximum HP .....	1.00	Avg. Air Consumption .....	11.9 cfm



2-1/2"



Wheel not included

## Michigan Pneumatic Model MP-314

### 4" Angle Grinder - with Guard

Features a floating rotor design extending the operational life of the tool by reducing wear on critical components. Compact, adjustable angle head is ideal for close quarter applications.

Capacity .....	4"	Length .....	10"
Free Speed .....	13500 rpm	Weight .....	2.9 lbs.
Spindle Thread .....	3/8"-24	Air Inlet Thread .....	1/4"
Maximum HP .....	1.00	Avg. Air Consumption .....	12 cfm

# Right Angle Grinders



3-1/4"



Wheel not included

## Michigan Pneumatic Model MP-250L-ST58

### 5" Angle Grinder - with Guard

Durable, right angle grinder used for grinding, deburring and blending. Rugged, lightweight angle grinder for many applications. Removes rust and paint fast. Great for dressing up welds and grinding complex shapes. Features safety lever throttle and governor. **Equipped with 5" guard and dead handle.**

Capacity.....	5"	Length.....	9"
Free Speed.....	12000 rpm	Weight.....	4.5 lbs.
Spindle Thread.....	5/8"-11	Air Inlet Thread.....	1/4"
Maximum HP.....	1.00	Avg. Air Consumption.....	10 cfm



3-3/4"



Wheel not included

## Michigan Pneumatic Model MP-1954PS-ST

### 5" Angle Grinder - with Guard

Features rear exhaust. Lightweight, heavy-duty angle grinder with adjustable swivel guard and reduced vibration dead handle. Change abrasives easier using the integrated spindle lock mechanism. **Equipped with 5" guard and dead handle.**

Capacity.....	5"	Length.....	9-13/32"
Free Speed.....	10000 rpm	Weight.....	4.4 lbs.
Spindle Thread.....	5/8"-11	Air Inlet Thread.....	1/4"
Maximum HP.....	0.87	Avg. Air Consumption.....	4 cfm



3-3/4"



Wheel not included

## Michigan Pneumatic Model MP-11650

### 5" Angle Grinder - with Guard

Features adjustable side exhaust. All steel housing with safety lever throttle. Used for grinding, deburring and blending. Features a wick-type lubrication system and spiral beveled gears. **Model MP-11650A with aluminum motor housing available. Equipped with 5" guard and dead handle.**

Capacity.....	5"	Length.....	7-1/2"
Free Speed.....	11000 rpm	Weight.....	5 lbs.
Spindle Thread.....	5/8"-11	Air Inlet Thread.....	1/4"
Maximum HP.....	1.00	Avg. Air Consumption.....	11.9 cfm

## NPK

4-3/8"



Wheel not included

## Nippon Pneumatic Model NAG-11A-U5

### 5" Angle Grinder - with Guard

Features rear exhaust. Change abrasive in seconds. No more fumbling with multiple wrenches. Simply depress the spindle locking mechanism on top of the housing and remove the abrasive product. Features a left or right hand dead handle, two-step safety lever throttle, and a composite plastic handle. **Equipped with 5" guard and dead handle.**

Capacity.....	5"	Length.....	9-7/8"
Free Speed.....	12000 rpm	Weight.....	4.5 lbs.
Spindle Thread.....	5/8"-11	Air Inlet Thread.....	3/8"
Maximum HP.....	0.87	Avg. Air Consumption.....	28 cfm

## NPK

4-3/16"



Wheel not included

## Nippon Pneumatic Model NAG-70ALW

### 7" Angle Grinder - with Guard

Features side exhaust. Heavy-duty grinder designed for continuous service. Lever type throttle allows operator to run full speed for metal removal or throttle down for delicate work. **Equipped with 7" guard and dead handle. Model NAG-70ALWSS with 5/8"-11 threaded spindle also available, allowing for the use of type 27 threaded hubs.**

Capacity.....	7"	Length.....	11-1/32"
Free Speed.....	7600 rpm	Weight.....	6.8 lbs.
Spindle Thread.....	5/8"-11	Air Inlet Thread.....	3/8"
Maximum HP.....	1.30	Avg. Air Consumption.....	42 cfm

See pages 59-61 & 72-73 for grinder accessories.



# Right Angle Grinders & Sanders



MP-6166-ST



MP-3765-ST



MP-717-ST

Quality beveled gears, ball bearing construction and powerful 1HP motor offer unmatched performance for the toughest sanding/grinding jobs. Lightweight aluminum housing to reduce operator fatigue. **Grinding wheel not included.**

Model No.	Capacity	Free Speed	Spindle Thread	Height	Length	Weight	Air Inlet Thread	Avg. Air Consumption
MP-6166-ST		2500 rpm		4"	12"	4.40 lbs.	1/4"	6 cfm
MP-3765-ST	7"	4500 rpm	5/8"-11	4"	12-3/4"	4.75 lbs.	1/4"	9 cfm
MP-717-ST		6000 rpm		4-1/4"	13-1/2"	8.00 lbs.	3/8"	9 cfm



5-3/8"

Wheel not included

## Michigan Pneumatic Model MP-2FA Angle Grinder - with Guard

Rugged, unusually powerful, heavy-duty tool for steady production grinding. Maintains cutting speed under load. Removes metal fast with less operator effort. Available with cup wheel or wire brush for grinding, or rubber pad for sanding. Model MP-2FA-ROLL with roll type throttle available.

Capacity .....	7"	Length .....	12-5/8"
Free Speed .....	7100 rpm	Weight .....	9 lbs.
Spindle Thread .....	5/8"-11	Air Inlet Thread .....	3/8"
Maximum HP .....	1.50	Avg. Air Consumption .....	42 cfm



5-3/8"

Wheel not included

## Michigan Pneumatic Model MP-2FW Angle Grinder - with Guard

Powerful heavy-duty grinder designed to withstand the continuous service encountered in plants. Lever type throttle allows operator to throttle down for delicate work or run full speed for maximum metal removal. Equipped with a lever throttle. Available with wire brush. Model MP-2FW-ROLL with roll type throttle available. Optional cup guard also available.

Capacity .....	9"	Length .....	12-5/8"
Free Speed .....	5500 rpm	Weight .....	9.5 lbs.
Spindle Thread .....	5/8"-11	Air Inlet Thread .....	3/8"
Maximum HP .....	1.50	Avg. Air Consumption .....	42 cfm

See pages 72-73 for grinder accessories.



MP-1165-WATER



MP-3760-WATER



MP-7170-WATER

Quality beveled gears, ball bearing construction and powerful **1HP motor** offer unmatched performance for the toughest sanding/grinding jobs. Lightweight aluminum housing to reduce operator fatigue. **Wheel not included.**

Model No.	Capacity	Free Speed	Spindle Thread	Height	Length	Weight	Air Inlet Thread	Avg. Air Consumption
MP-1165-WATER	5"	11000 rpm		4-1/4"	7-1/2"	4.25 lbs.		11.9 cfm
MP-3760-WATER	7"	4500 rpm	5/8"-11	4"	12-3/4"	5.50 lbs.	1/4"	9.0 cfm
MP-7170-WATER	7"	6000 rpm		4-1/4"	13-1/2"	8.75 lbs.		9.0 cfm



5-3/8"



Wheel not included

## Michigan Pneumatic Model MP-2FA-WATER

### Extra Heavy-Duty Water Feed Sander/Grinder

Heavy-duty grinder designed for continuous service. Lever type throttle allows operator to run full speed for metal removal or throttle down for delicate work. Equipped with dead handle 7" guard and 6 ft. hose with standard water faucet connector. Available with cup wheel or wire brush for grinding, or rubber pad for sanding.

Capacity	7"	Length	12-5/8"
Free Speed	7100 rpm	Weight	10.25 lbs.
Spindle Thread	5/8"-11	Air Inlet Thread	3/8"
Maximum HP	1.50	Avg. Air Consumption	42 cfm



5-3/8"



Wheel not included

## Michigan Pneumatic Model MP-2FW-WATER

### Extra Heavy-Duty Water Feed Sander/Grinder

Rugged, unusually powerful, heavy-duty tool for steady production grinding. Maintains cutting speed under load. Removes metal fast with less operator effort. Equipped with dead handle, 9" guard and 6 ft. hose with standard water faucet connector. Available with cup wheel or wire brush for grinding, or rubber pad for sanding. Model MP-2FWRT-WATER with roll type throttle available.

Capacity	9"	Length	12-5/8"
Free Speed	5500 rpm	Weight	10.75 lbs.
Spindle Thread	5/8"-11	Air Inlet Thread	3/8"
Maximum HP	1.50	Avg. Air Consumption	42 cfm



# Vertical Grinders



## Michigan Pneumatic Model MP-5666VSC

### Vertical Grinder - with Cup Wheel Guard

Features a high force, corrosion resistant governor to retain optimum grinding efficiency and hardened steel motor parts. Provides heavy-duty grinding for smoothing; finishing, removing scale, rust and weld splatter; cleaning castings and masonry work. Ideal for a variety of applications in fabrication shops, refineries, shipyards, steel mills and construction sites.

MP-5646VSC 4500 rpm, 6" cup wheel grinder also available.



Wheel not included

Capacity.....	6" Cup Wheel	Height.....	7-3/4"
Free Speed.....	6000 rpm	Weight.....	10.25 lbs.
Spindle Thread.....	5/8"-11	Rec'd Hose Size.....	1/2"
Maximum HP.....	3.00	Air Inlet Thread.....	1/2"

## Michigan Pneumatic Model MP-5667VS

### Vertical Grinder - with Guard

Features include hardened steel motor parts and a high force, corrosion resistant governor to retain optimum grinding efficiency. Ideal for heavy-duty grinding for smoothing; finishing, removing scale, rust and weld splatter; cleaning castings and masonry work. Applications include fabrication shops, refineries, shipyards, steel mills and construction sites.



Wheel not included

Capacity.....	7"	Height.....	7-5/8"
Free Speed.....	6000 rpm	Weight.....	9.60 lbs.
Spindle Thread.....	5/8"-11	Rec'd Hose Size.....	1/2"
Maximum HP.....	3.00	Air Inlet Thread.....	1/2"

## Michigan Pneumatic Model MP-6666VSC

### Vertical Grinder - with Cup Wheel Guard

Ideal for fabrication shops, refineries, shipyards, steel mills and construction sites. Features a high force, corrosion resistant governor to retain optimum grinding efficiency and hardened steel motor parts. Provides heavy-duty grinding for smoothing; finishing, removing scale, rust and weld splatter; cleaning castings and masonry work. MP-6646VSC 4500 rpm, 6" cup wheel grinder also available.



Wheel not included

Capacity.....	6" Cup Wheel	Height.....	8-5/16"
Free Speed.....	6000 rpm	Weight.....	11.0 lbs.
Spindle Thread.....	5/8"-11	Rec'd Hose Size.....	1/2"
Maximum HP.....	4.00	Air Inlet Thread.....	1/2"

## Michigan Pneumatic Model MP-6669VS

### Vertical Grinder - with Guard

Features a high force, corrosion resistant governor to retain optimum grinding efficiency and hardened steel motor parts. Provides heavy-duty grinding for smoothing; finishing, removing scale, rust and weld splatter; cleaning castings and masonry work. Ideal for a variety of applications in fabrication shops, refineries, shipyards, steel mills and construction sites.

MP-6667VS 7" vertical grinder also available.



Wheel not included

Capacity.....	9"	Height.....	8-3/16"
Free Speed.....	6000 rpm	Weight.....	10.90 lbs.
Spindle Thread.....	5/8"-11	Rec'd Hose Size.....	1/2"
Maximum HP.....	4.00	Air Inlet Thread.....	1/2"

# Vertical Grinders



## Michigan Pneumatic Model MP-5669VS

### Vertical Grinder - with Guard

Features include hardened steel motor parts and a high force, corrosion resistant governor to retain optimum grinding efficiency. Ideal for heavy-duty grinding for smoothing; finishing, removing scale, rust and weld splatter; cleaning castings and masonry work. Applications include fabrication shops, refineries, shipyards, steel mills and construction sites.



Wheel not included

Capacity.....	9"	Height.....	7-5/8"
Free Speed.....	6000 rpm	Weight.....	10.25 lbs.
Spindle Thread.....	5/8"-11	Rec'd Hose Size.....	1/2"
Maximum HP.....	3.00	Air Inlet Thread.....	1/2"

## Michigan Pneumatic Model MP-B6001M-45

### Vertical Grinder - with Cup Wheel Guard

Vertical grinder designed for tough, extra-duty grinding jobs. Outstanding for general clean-up of all size castings, removal of scale, rust or paint by wire brushing and grinding butt welds. Provides maximum power under the worst operating conditions. Lightweight alloy housing allows for easy control and handling. **6" cup wheel guard with butterfly throttle is standard. Optional 9" wheel guard available. Parts are interchangeable with the Master and B&D 601 grinders.**



Wheel not included

Capacity.....	6" Cup Wheel	Height.....	8"
Free Speed.....	4500 rpm	Weight.....	12 lbs.
Spindle Thread.....	5/8"-11	Rec'd Hose Size.....	1/2"
Maximum HP.....	3.00	Air Inlet Thread.....	1/2"

## Michigan Pneumatic Model MP-B3199C-45

### Vertical Grinder - with Cup Wheel Guard

Heavy-duty surface grinder designed for continuous production sanding and grinding in industrial plants. Will handle a large variety of surface grinding applications. Ideal for smoothing flat surfaces and cutting down high spots. Lightweight and easy to handle. **Parts are interchangeable with the CP Model 319 grinder. Features safety lever throttle.**



Wheel not included

Capacity.....	6" Cup Wheel	Height.....	7-3/8"
Free Speed.....	4500 rpm	Weight.....	8.5 lbs.
Spindle Thread.....	5/8"-11	Rec'd Hose Size.....	1/2"
Maximum HP.....	2.00	Air Inlet Thread.....	1/2"

## Michigan Pneumatic Model MP-B3199CLW-6

### Vertical Grinder - with Guard

Best suited for grinding and sanding flat surfaces. Ideal for sheet metal finishing, cleaning and grinding castings, and smoothing welds. Perfect for cup wheel grinding, cup wire brushing and disc sanding. Designed for heavy-duty use. **Parts are interchangeable with the CP Model 319 grinder. Features safety lever throttle.**



Wheel not included

Capacity.....	7"	Height.....	7-3/8"
Free Speed.....	6000 rpm	Weight.....	8.5 lbs.
Spindle Thread.....	5/8"-11	Rec'd Hose Size.....	1/2"
Maximum HP.....	2.00	Air Inlet Thread.....	1/2"



# Grinder & Sander Accessories



## Spiralcool Air-Cooled Backing Pads

Spiralcool air cooled pads feature reduced loading and increased disc life. Ideal for all sanding operations on metal, fiberglass and plastics. Flexible or medium grade recommended for contour work and rigid for straight edge work. Fits any sander or grinder with 5/8"-11 thread.

Part Number			Size
Flexible	Medium	Rigid	
F400-R	R400-R	H400-R	4"
F500-R	R500-R	H500-R	5"
F600-R	R600-R	H600-R	6"
F700-R	R700-R	H700-R	7"
F800-R	R800-R	H800-R	8"
F900-R	R900-R	H900-R	9"



## Sav-A-Disc Backing Plate

Unique rib design prevents the abrasive disc from loading when grinding results in more than 3 times normal disc wear. Includes 7" and 9" plates.

- Cuts faster
- Results in cool grinding
- Reduces worker fatigue
- Increases disc life
- Patented free wheeling hub
- 5/8"-11 arbor



BP-1 Set

## Twist Knotted Cup Brushes

Well suited for use on portable equipment for cleaning and removing rust, scale and paint on flat and contoured surfaces. Flat knot type wire wheels available.



Part No.	Dia.	Wire Size	Arbor Hole	Trim Length	Max. RPM
<b>Single Row, Twist Tuft Cup Brushes</b>					
03407	4"	.020"	5/8"-11	1-3/8"	9000
03409	6"	.020"		1-3/4"	6600
03410	6"	.035"		1-3/4"	6600
<b>Double Row, Twist Tuft Cup Brushes</b>					
03411	6"	.020"	5/8"-11	1-3/4"	6600
03412		.035"			

## Crimped Wire Cup Brushes

Hard working cups with solid ring construction designed for safer brushing action. Very popular in auto body shops for removal of paint and plastic body filler.



Part No.	Dia.	Wire Size	Arbor Hole	Trim Length	Max. RPM
09551	4"	.020"	5/8"-11	1-1/8"	9000
09552	5"			1-1/2"	8000
09553	6"			1-1/2"	6600

## Grinding Wheels with Depressed Center

MPT abrasive grinding wheels are reinforced with fiberglass to ensure safe operation and long life. In use, natural pores are created as the special resinoid fillers are melted by grinding heat, constantly renewing high cutting efficiency.

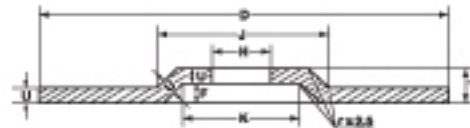

### Type 27 Depressed Center Wheel with Through Hole

Part No.	Diameter "D"	Thick "U"	Hole "H"	RPM
T27-41858	4"	1/8"	5/8"	13500
T27-41458	4"	1/4"	5/8"	13500
T27-71878	7"	1/8"	7/8"	8500
T27-71478	7"	1/4"	7/8"	8500
T27-91878	9"	1/8"	7/8"	6500
T27-91478	9"	1/4"	7/8"	6500

### Type 27 Depressed Center Wheel with 5/8"-11 Threaded Hub

Part No.	Diameter "D"	Thick "U"	Hole "H"	RPM
20163	4-1/2"	1/4"	5/8"-11	13300
20173	5"			12200
20086	7"			8500
20096	9"			6500

## Twist Knot Flat Wire Wheels



Standard tufts are twisted 2/3 of their length. Satisfactory for the majority of applications where severe cleaning action is required. Stainless wheels available.

Part No.	Dia.	Wire Size	Arbor Hole	Trim Length	Max. RPM
03377	3"	.014"	3/8"	11/16"	20000
03378	4"	.014"	1/2"	7/8"	20000
03386	6"	.020"	5/8"-1/2"	1-7/16"	9000
03426	4"	.014"	5/8"-11	7/8"	20000
03430		.014"	1/2"-13		
03460		.020"	5/8"-11		

See pages 59-61 & 73 for additional grinder accessories.

# Grinder & Sander Accessories



## JET Bench Grinders



JBG-6A



JBG-8A

Designed and manufactured for continuous industrial service. All models feature pre-lubricated and enclosed ball bearings, cast iron wheel guards and dust vents. All models also include adjustable one-piece spark guards, large eye shields and tool rests. **OSHA approved.**

Model No.	Dimensions	Wheel Size	Motor	Speed	Weight
JBG-6A	18" x 10-1/2" x 8-1/2"	6" x 3/4" x 1/2"	1/2 HP	3450 rpm	32 lbs.
JBG-8A	19" x 12-1/2" x 10"	8" x 1" x 5/8"	1 HP	3450 rpm	54 lbs.
JBG-10A	24-1/2" x 12-1/4" x 13"	10" x 1" x 1"	1-1/2 HP	1725 rpm	110 lbs.

## Abrasive Belts - Aluminum Oxide



Size	Grit	Part No.
3/8" x 13"	40	61122
	60	61124
	80	61125
	100	61126
	120	61127

Size	Grit	Part No.
3/4" x 20-1/2"	40	60129
	60	60131
	80	60132
	100	60133
	120	60134
1-3/16" x 21"	60	TP04084-0
	80	TP04085-0
	100	TP04086-0

Additional sizes, grit and material belts available.

## Cones, Plugs & Cup Wheels

### Type 16 Plug

Part No.	Dia A	Length B	Hole C	RPM
25005	2"	3"	3/8"-24	18100
25006	2"	3"	5/8"-11	18100

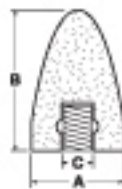

### Type 17 Plug

Part No.	Dia A	Length B	Hole C	RPM
25105	2"	3"	3/8"-24	18100
25106	2"	3"	5/8"-11	18100



### Type 18 Plug

Part No.	Dia A	Length B	Hole C	RPM
25205	2"	3"	3/8"-24	18100
25206	2"	3"	5/8"-11	18100

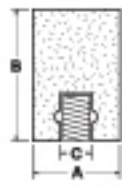

### Type 18R Plug

Part No.	Dia A	Length B	Hole C	RPM
25305	2"	3"	3/8"-24	18100
25306	2"	3"	5/8"-11	18100

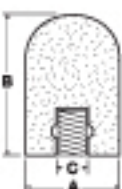

### Type 11 Cup Wheel

Part No.	Dia A	Length B	Hole C	RPM
26010	5"	2"	5/8"-11	7250
26020	6"	2"	5/8"-11	6050

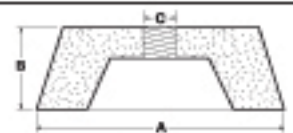

## Grinding & Cut-Off Wheels



### Grinding Type 1 Flat - with Through Hole

Part No.	Diameter A	Thick B	Hole C	RPM
T1-21238	2"	1/2"	3/8"	25000
T1-2121238	2-1/2"	1/2"	3/8"	22000
T1-45812	4"	5/8"	1/2"	11000
T1-53412	5"	3/4"	1/2"	9000
T1-6158	6"	1"	5/8"	6500
T1-8158	8"	1"	5/8"	7000

### Cut-Off - with Through Hole

Part No.	Diameter A	Thick B	Hole C	RPM
F41638	4"	1/16"	3/8"	19000
F41838		1/8"	3/8"	
F41438		1/4"	3/8"	
F41858		1/8"	5/8"	

See pages 59-61 & 72 for additional grinder accessories.



# Miscellaneous Tools



Michigan Pneumatic

## Punch/Flange Tools

Two-in-one quarter-paneling tool is ideal for crimping or flanging panels together. Also great for punching clean holes for any operation.



MP-AP650-ST



MP-AP600ST8



MP-AP600PT-A

Model No.	Punch Capacity	Flange Capacity	Length	Weight	Rec'd Hose Size	Air Inlet Thread	Avg. Air Consumption
MP-AP600PT-A	3/16" Hole	14 gauge	7-1/2"	2.25 lbs.			
MP-AP650-ST	3/16" Hole	14 gauge	9-5/8"	2.70 lbs.	3/8"	1/4"	4 cfm
MP-AP600ST8	5/16" Hole	14 gauge	10"	3.00 lbs.			

Michigan Pneumatic **MP-050K-DD**

## Punch/Flange Tool Kit

Two-in-one quarter-paneling tool is ideal for crimping or flanging panels together. Also great for punching clean holes for any operation. Includes plastic case, one flange head, and 4 punch heads (Sizes 4, 5, 6.5, & 8mm).



4mm

5mm

6.5mm

8mm

Flange Head

Punch Capacity .....	5/16" Hole	Rec'd Hose Size .....	3/8"
Flange Capacity .....	15 gauge	Air Inlet Thread .....	1/4"
Length .....	11-7/32"	Avg. Air Consumption .....	4 cfm
Weight .....	2.86 lbs.		

Michigan Pneumatic **Model MP-9361**  
**Model MP-9100**

## Engraving Pen

Writes on a variety of materials such as steel up to RC-64, glass, plastic and wood. Can be used for deburring and trimming, and is excellent for removing broken studs. A must for paleontologists and aircraft parts manufacturers. Includes hose, filter, #7177 stylus and plastic carrying case.

MP-9100



MP-9361



- #7177 Carbide Tip Stylus
- #84625 Solid Carbide Stylus Kit  
Includes: 1 Solid Carbide Stylus, 2 O-rings, 1 Special Guide
- #7425 Chisel Kit (MP-9361 only)  
Includes: 1 each Wide Chisel, Blank Chisel, Cape Chisel & Anvil

Length .....	5"
Weight .....	5 oz.
Rec'd Hose Size .....	1/4"
Air Inlet Thread .....	1/8"
Avg. Air Consumption .....	1 cfm



Michigan Pneumatic **Model MP-AS8-ST**

## Paint Spray Gun

High production spray gun designed to handle all lacquers, enamels, and any automotive refinishing materials.



Feed Type .....	Suction
Fluid Nozzle Size .....	5/8"
Cup Capacity .....	1 Quart
Height .....	11-1/2"
Length .....	5"
Weight .....	2.3 lbs.
Rec'd Hose Size .....	3/8"
Air Inlet Thread .....	1/4"
Avg. Air Consumption .....	8 cfm