

# KALAMAZOO INDUSTRIES

FULL LINE CATALOG



ABRASIVE SAWS  
BELT SANDERS  
DISC SANDERS  
LATHE CHUCKS  
INDEX FIXTURES  
DUST COLLECTORS

CATALOG K09

## 7" CUT-OFF SAW - 1 HP

## 8" CUT-OFF SAW - 3 HP

**Cast iron BASE PROVIDES RIGID ALIGNMENT**



### MODEL K7B

- Handles 1" solid round, 2" pipe.
- Adjustable work length stop and down stop furnished.
- 1/2" wheel arbor.
- Dimensions - L 22" x W 10" x H 14"

**MODEL K7B** 7" abrasive cut-off saw. 1 HP TEFC motor, 1 PH (110/220V). Please specify voltage. With cord and switch. Less abrasive wheel. 75 lbs. Spindle RPM - 4800.

### MODEL K8B

- More capacity, cuts 1-1/2" solid, 2" pipe.
- 1/2" wheel arbor.
- Spark deflectors, front and rear, standard.
- Dimensions - L 22" x W 10" x H 14"

**MODEL K8B** 8" abrasive cut-off saw. 3 HP TEFC motor, 1 PH (110/220V) or 3 PH (220/440V). Please specify voltage. With switch; less abrasive wheel. 90 lbs. Spindle RPM - 4900.

## 10" WET SAW

**MODEL K10SW** 10" wet abrasive saw, 3 HP, 1 PH (220V only) or 3 PH (220/440V), 3450 RPM motor. Wt. 300 lbs.

- Magnetic switch.
- 2300 spindle speed with 3450 RPM motor.
- 5/8" spindle arbor. Optional: 1 1/4", 32mm
- Uses 10" abrasive wheel, not included.
- Cam lock vise.
- 10-gallon coolant tank with pump.
- Splash guard.
- Heavy-duty cast iron base and trunnion.
- Dimensions - L 36" x W 26" x H 62"



*Optional: PH-14 air/oil Power down feed  
Optional: AV-10 Air vise*

## 10" SAWS - 3 HP

**BIG JOB CAPACITY  
1-1/2" SOLIDS, 2-1/2" PIPE**



### MODEL K10B

- Swivel vise opens 4"-fast, lever-lock
- 5/8" arbor, sealed-for-life bearings.
- Dimensions - L 23" x W 10" x H 14".

Optional heavy steel floor stand and foot-operated chain vise (in place of swivel vise).

**MODEL K10B** 3 HP TEFC motor, 1 PH (110/220V) or 3 PH (220/440V). Please specify voltage. With switch and vise. Less abrasive wheel. 110 lbs. Spindle RPM - 3450.

<b>K10B</b>	10" Saw, bench model, swivel vise.....	110 lbs.
<b>K10S</b>	10" Saw, steel stand, swivel vise.....	170 lbs.
<b>K10SF</b>	10" Saw, bench model, chain vise.....	180 lbs.



### MODEL K10SW



# 12" and 14" SAWS - 5 HP

## MODEL K14SS



These heavy-duty saws handle 2-1/2" solid round stock, 3" pipe with speed and efficiency.

- Extra-heavy Cast iron base, trunnion and arm.
- Sealed ball bearings, 1" wheel arbor.
- Positive, quick-lock swivel vise, opens 4".
- Dual V-belt drive.
- 5 HP, TEFC. 1 PH (220 volt only) or 3 PH (220 or 440V, please specify voltage).
- Spindle RPM – 4400.
- Dimensions – L 22" x W 14" x H 24".
- Less abrasive wheel.

## MODEL K14B



	12" SAW	WT.	14" SAW	WT.
Bench Saw, swivel vise, manual switch	K12B	220 lbs.	K14B	220 lbs.
Floor Saw, swivel vise, manual switch	K12SS	270 lbs.	K14SS	270 lbs.
Floor Saw, chain vise, manual switch	K12SSF	300 lbs.	K14SSF	300 lbs.



## MODEL K12-14W

- Magnetic switch.
- 2200 spindle speed with 1725 RPM motor.
- 1" spindle arbor.
- Uses 12" or 14" abrasive wheel, not included.
- Two cam lock vises.
- 10-gallon coolant tank with pump.
- Splash guard.
- Heavy-duty Cast iron arm and trunnion.
- Heavy-duty base.
- Optional work length stop (Model KWL).
- Dimensions : L 36" x W 26" x H 62".

**MODEL K12-14W** 12" or 14" wet abrasive cut-off saw, 5 HP, 1 PH (220V only) or 3 PH (220V/440V), 1725 RPM motor. Wt. 705 lbs.

### Options Available

Power down feed, air vise, conveyors.....  
See page 21



Option: PH-14 air/oil  
Power down feed



## MODEL K12-14V

- Model K12B or K14B mounted on DCV-6 dust collector/vacuum. 400 CFM with hood.
- Dust collector has replaceable filter element.
- Manual switch on saw and dust collector.
- Dimensions — L 25" x W 17" x H 55".

**MODEL K12-14V** 5 HP, 3 PH abrasive saw. Uses 12" or 14" abrasive wheels. 1" wheel arbor. Available 1 PH (220V only) or 3 PH (220/440V); please specify. 4400 spindle RPM. Wt. 525 lbs.



# ABRASIVE METALLURGICAL SAW

- 5 HP, 3 PH 1725 RPM TEFC motor, 12 amps @ 230V, 6 amps @ 460V.
- External manual operation.
- Dual moveable 4" screw vises.
- Capacity 2-1/2" solid, 3" shapes.
- Magnetic switch.
- Internal halogen light – 24 volt.
- 1" wheel arbor, 12" or 14" blade, not included.
- Dual coolant nozzles.
- 2200 spindle speed at 1725 RPM.
- Flood coolant, 10 gal., 1/3 HP.
- Dimensions — L 39" x W 26" x H 60".

**MODEL K12-14MS** 5 HP, 3 PH TEFC (220/440V); please specify. 1725 RPM. Enclosed wet cutting metallurgical saw. Wt. 775 lbs.



**MODEL K12-14MS**

### Options Available

Power down feed, oscillation, air vise, infeed/outfeed stock conveyors. See page 21.



**MODEL K10WBT**



## 10" WET Benchtop

- Manual operation.
- Magnetic switch.
- Dual 3" vises.
- Capacity: 1.5" solids, 2.5" pipe.
- Internal lite.
- Coolant & pump.
- Dual coolant nozzles.
- 5/8" LH spindle arbor, optional: 1.250" or 32mm.
- T-Slot Table.
- 10" Diameter abrasive blade (not included).
- Dimensions : L 24" x W 24" x H 24".

**MODEL K10WBT** 2hp TEFC motor, 3 phase, 220/440 volt, please specify voltage. 3450 RPM at spindle, Wt. 250 lbs.

## 16" - 18" CUT-OFF SAW

### MODEL K16-18



- 16" or 18" diameter abrasive wheel, not included.
- Rugged cast iron trunnion and arm. Super rigid, super accurate.
- Heavy-duty guards, efficient spark chute.
- Fast, foot-operated chain vise.
- 1" wheel arbor.
- Sealed ball bearings.
- Table 16" wide x 28" deep.
- Capacity 3" solid, 4" pipe.
- 2500 spindle RPM.
- 10 HP TEFC motor. 24 amps @ 230V, 12 amps @ 460V.
- Dimensions — L 41" x W 24" x H 55".

**MODEL K16-18** 10 HP TEFC saw duty motor, 3 phase (220/440V); please specify. Magnetic starter with overload protection. Less abrasive wheel. Wt. 600 lbs.



### PH-20 Options Available

Power down feed, oscillation, air vise, conveyors...  
See page 21.

## 20" SAW - 15 HP

- 20" abrasive wheel, not included.
- Rugged cast iron trunnion and arm. Super rigid, super accurate.
- Heavy-duty guards, efficient spark chute.
- Fast, foot-operated chain vise.
- 1" wheel arbor.
- Sealed ball bearings.
- Table 18" wide x 30" deep.
- Capacity 4" solid, 6" shapes.
- 2500 spindle RPM.
- Optional work stop (WL-20).
- Optional dust collector (DCV-1).
- Dimensions — L 41" x W 24" x H 55".

### ADD A STOCK CONVEYOR!

See page 21.



### MODEL K20SSF



**MODEL K20SSF-15** 15 HP TEFC saw duty motor, 3 phase (220/440V); please specify. Magnetic starter, adjustable down stop, less abrasive wheel. Wt. 680 lbs.

**MODEL K20SSF-20** 20 HP TEFC saw duty motor, 3 phase (220/440V); please specify. Magnetic starter, adjustable down stop, less abrasive wheel. Wt. 700 lbs.

## 20" SEMI-AUTOMATIC WET CUT SAW

- Capacity: 4" solid, 6" shapes.
- Air-over-oil precise feed control.
- 0–12 FPM feed rate.
- Air chain vise.
- Coolant pump, 10 gal., 1/3 HP.
- Cast iron upper arm/trunnions.
- Dual coolant hoses.
- Magnetic switch.
- Steel saw top, 27" x 30".
- Semi-automatic operation — saw head returns at end of cut. Manual stock feed.
- 0–100 PSI air required.
- Spindle speed: 1,950 RPM.
- Table dimensions: 12"x27".
- Dimensions : L 50" x W 34" x H 60".

**MODEL K20SW-PHV** 15 HP TEFC, 3 PH, 220/440V, please specify voltage. Magnetic switch, power down feed, air vise, 10-gallon coolant pump and tank. Optional: 20 HP motor and oscillation. Less abrasive wheel. Wt. 1500 lbs.

**MODEL K20SW-PHV**



**TOTALLY ENCLOSED MODELS AVAILABLE.**

**MODEL K20SW**



## 20" WET CUT-OFF SAW

- 20" manual wet-cut abrasive saw.
- Cast iron arm, trunnions.
- 15 HP TEFC motor, 220/440V, please specify voltage.
- Manual cam vise.
- Integral tank and pump.
- Magnetic switch.
- 4" solid bar, 6" shape capacity.
- Spindle speed: 1,950 RPM.
- Dual coolant hoses.
- Table dimensions: 12"x27".
- Dimensions — L 50" x W 34" x H 60".

**MODEL K20SW** 20" cut-off saw, 15 HP TEFC, 220/440V, 3 PH. Please specify voltage. Standard equipment: magnetic switch, coolant pump, manual vise, less wheel. Optional equipment: 20 HP, work stop, oscillation, air vise. Wt. 1450 lbs.



**STOCK CONVEYORS**

**Options Available**

Power down feed, air vise, conveyors.....  
See page 21

# 20" ENCLOSED SEMI-AUTOMATIC WET CUT SAW



## MODEL K20E

- Totally enclosed cabinet.
- 15 HP SD motor, mag. starter, 36 amps @ 230V, 18 amps @ 460V.
- V-belt drive, sealed ball bearings.
- Capacities: 4" solid, 6" shapes.
- Air chain vise.
- 1" spindle arbor, 1950 RPM.
- Coolant pump, 10 gal., 1/3 HP.
- Dual coolant hoses.
- Internal light.
- Front and side access doors.
- Semi-automatic: saw head returns at end of cut. Manual stock feed.
- Air over oil precise downfeed.
- Adjustable down stop limits depth of cut.
- Dimensions — L 50" x W 34" x H 80".
- Options: Oscillation, side access ports for long stock.

**MODEL K20E** 15 HP TEFC saw duty motor, 3 PH, 220/440V (please specify). Uses wet cutting abrasive wheel, not included. Wt. 1600 lbs.

# 26" ABRASIVE SAW

## MODEL K26S

- 20 HP TEFC Standard, 54 amps @ 230V, 27 amps @ 460V
- Cam vise — 4-1/2" high.
- Spindle speed 1800 RPM.
- 7" flanges.
- 1" arbor.
- Table 32" wide x 42" deep x 26" high.
- Opening in guard 9" x 16".
- Heavy safety guard.
- Down stop.
- Specs — cuts 7" pipe, 5" solids, 8" shapes, 12" channels.
- Dimensions — L 42" x W 32" x H 62".

**MODEL K26S** 20 HP, 3 phase 220/440V with magnetic switch, 1725 RPM, 1800 RPM spindle speed. Options available: power down feed, wet tray with coolant pump, oscillation on head, vacuum dust collector. Wt. 1300 lbs.

### Options Available

Power down feed, air vise, conveyors.....  
See page 21



**ADD A STOCK  
CONVEYOR!**





# 26", 30" ABRASIVE SAWS

## MODEL K26E

- 26" abrasive saw.
- 20 HP, 3 PH motor (Optional: HP - 30, 50).
- Cam vise.
- Cog belt drive.
- Totally enclosed with 6" outlet.
- Power down feed — air/oil, 0–12 FPM.
- 1" wheel arbor, 7" flanges.
- 1800 RPM spindle speed.
- Capacity 7" pipe, 5" solids, 8" shapes.
- Dimensions — L 61" x W 48" x H 92".
- Optional: Oscillation: gear/motor or hydraulic, coolant, wheel wear compensator.

**MODEL K26E** 20 HP, 3 PH motor 220/440V with mag switch. Totally enclosed. Wt. 1700 lbs. Options available: wet/coolant system, vacuum dust collector.



## SPECIALS AVAILABLE!



### Options Available

Power down feed, air vise, conveyors.....  
See page 21



**ADD A STOCK  
CONVEYOR!**

### MODEL K30PH

- Power down feed - air/oil.
- 1-3/4" arbor with sealed ball bearings.
- Mag. starter.
- Capacities: 5" solids, 8" shapes.
- Dimensions — L 36" x W 24" x H 84".
- Optional: Totally enclosed, Hydraulic down feed.
- Oscillation: gear/motor or hydraulic, coolant, 30, 40, 50 HP.

**MODEL K30PH** 30" abrasive saw. 25 HP, 3PH 220/440V motor with mag switch. Wt. 1450 lbs.



## HI-SPEED NON-FERROUS MITRE SAW



- Non-ferrous saw for cutting aluminum, brass, plastic.
- Mitres 45° left or right.
- Capacities: 4.5" at 90°.
- 4" x 3.5" at 45°.
- 4400 spindle speed at 3450 RPM.
- Uses carbide tipped steel blade – not included.
- 1" spindle.
- Sealed ball bearings.
- Twin v-belt drive.
- Cast iron construction.
- Dual cam-lock vise.
- OSHA safety blade guard.

**MODEL KM14HS**

**MODEL KM14HS** 14" high speed non-ferrous mitre saw. 5 HP TEFC, 3 PH 220/440V (please specify voltage) or 5 HP 1 PH 220V. Manual switch. Wt. 570 lbs. Dimensions L 26" x W 24" x H 50". LESS BLADE.

## SEMI-AUTOMATIC NON-FERROUS SAW



*FOR CUTTING ALUMINUM AND OTHER NON-FERROUS MATERIAL WITH STEEL BLADE.*

**MODEL HSM14**

- Semi-automatic.
- 14" blade (not furnished).
- Double V-belt drive.
- 5 HP, 3PH, 1750 RPM with mag. starter.
- 4400 spindle speed at 3450 RPM.
- Power down feed, air/oil, 0 - 12 FPM.
- Double air vises.
- Mitre both ways at 45°.
- Vise opens 6".
- Spindle 1".

### HEAVY DUTY

Capacities: Pipe 4-1/2", Square 4-1/2"  
Dimensions: L 30" x W 48" x H 60"

**MODEL HSM14** 14" high speed mitre. 5HP TEFC, 3PH motor with magnetic starter, 3450 RPM. Please specify voltage. For non-ferrous only. Wt. 750 lbs. Optional: 1,725 RPM motor.

## NON-FERROUS 14" SAW

- OSHA safety Clamshell wheel-guard.
- Heavy cast iron base, trunnion and arm.
- Capacity: 4" square, round and shapes. 3" solid.
- Abrasive blade can also be used.
- Manual switch.
- 1" spindle.
- Sealed ball bearings.
- 5 HP, 3 phase 220 or 440 volt motor (single phase also available).
- Straight cut 90°.
- 4400 spindle speed at 3450 RPM.
- Double v-belt drive.
- Two easy-set screw vises.
- Opens 5" and holds work on both sides.



**MODEL HS14**

**MODEL HS14** 14" high-speed "straight-cut" non-ferrous saw. 5 HP, 3 PH 220 or 440 volt. Motor RPM 3450. Please specify voltage when ordering. Wt. 240 lbs. Optional: 1,725 RPM motor.

## 10" HI-SPEED NON-FERROUS MITRE SAW



**MODEL KM10HS**

- Non-ferrous saw for cutting aluminum, brass, plastic.
- Mitres 45° left, 60° right.
- Capacities: 4.5" at 90°, 4" x 3.25" at 45°, 2.25" at 60°.
- 3450 spindle speed at
- Uses carbide tipped blades (not included).
- 5/8" spindle arbor.
- Sealed ball bearings.
- V-belt drive.
- Dual cam-lock vises.
- OSHA safety blade guard.

**MODEL KM10HS** 10" high speed non-ferrous mitre saw. 3 HP TEFC, 3 PH 220/440V (please specify voltage) or 3 HP 1 PH 220V. Manual switch. Wt. 450 lbs. Dimensions L 25 x W 24 x H 17. LESS BLADE.

# ABRASIVE MITERING SAWS



**MODEL KM10**  
10" SAW – 3 HP

- 0°–45° left/right.
- Spindle RPM – 3450.
- Capacities – 1-1/2" solids, 2-1/2" shapes at 45°.
- Dimensions – L 25" x W 24" x H 17".
- Optional – WS10 workstop.
- Optional – 12M heavy-duty stand.

**MODEL KM10** 3 HP, 1 PH (110/220V) or 3 PH (220/440V); please specify voltage. Mitres either direction 45°. 5/8" wheel arbor. Positive index holes and up/down stops. Two cam lock vises, lever lock for table. Wt. 220 lbs.



**MODEL KM16-18**  
16 – 18" SAW

- 0°–45° left/right.
- Spindle RPM – 2500.
- Rugged cast iron arm and trunnion.
- Dimensions – L 33" x W 30" x H 59".
- Capacities –  
Straight: 3" solid, 4-1/2" pipe/shapes  
45°: 2-1/2" solid, 4" pipe/shapes.

**MODEL KM16-18** 10 HP saw duty, 3 PH motor; please specify voltage 220/440. Uses 16" or 18" abrasive wheel (not included). 1" wheel arbor. Mitres either direction 45°. Two cam vises. Low voltage manual starter. Dry model only (not available wet). Wt. 730 lbs.



**MODEL KM14**  
14" SAW – 5 HP

- 0°–45° left/right.
- Spindle RPM – 4400.
- Capacities – 2-1/2" solid, 3" pipe, 3.5" at 45°.
- Dimensions – L 26" x W 24" x H 50".
- Front table lock.
- Heavy-duty stand.

**MODEL KM14** 5 HP, 1 PH (220V only) or 3 PH (220/440V); please specify voltage. Mitres either direction 45°. 1" wheel arbor. Positive index holes and up/down stops. Two cam lock vises, lever lock for table. Wt. 400 lbs.



**MODEL KM20-22**  
20 – 22" SAW

**MODEL KM20-22** 15 HP saw duty, 3 PH motor; please specify voltage 220/440V. Magnetic starter. Air-operated chain vise standard. Uses 20" or 22" abrasive wheel (not included). 1" wheel arbor. Spindle RPM – 2500. 0°– 45° left/ right. Dimensions L 42" x W 51" x H 67". Wt. 1200 lbs.

**MODEL KM20-22W** 15 HP saw duty, 3 PH motor. Same as above, with wet system and magnetic starter. Capacities – Straight: 4" solid, 6" most shapes; at 45°: 3" solid, 5" shapes. Dimensions L 72" x W 60" x H 67". Wt. 1700 lbs.

# 10", 12", 14", 20" SAW ARM ASSEMBLIES



**ENGINEER YOUR OWN SYSTEM!  
MOUNT TO YOUR ASSEMBLY!  
AVAILABLE AS:  
ABRASIVE, NON-FERROUS, DRY CUT  
MANUAL OR SEMI-AUTOMATIC!**



**KM20AS**



**KM20AS** 16,18,20" arm assy., 15 HP, 3 PH (220/440 60 hz), Less switch, single 4 bolt trunnion mount, 1" arbor, 1/2 round guard, abrasive only, Spindle RPM 2500, Less wheels, Please specify voltage, Weight: 500 lbs.

**K20AS**



**K20AS** 16,18,20" arm assy., abrasive or non-ferrous blades. 15 HP, 3 PH (220/440 volt 60 hz), 1" arbor, Spindle RPM 2500, dual trunnion mount, less wheels/blades, less switch, Please specify voltage, Weight: 500 lbs.

**HS14AS**  
12" - 14" blade



**HS14AS** 12-14" blade, Non-ferrous arm assy., 5 HP, 1 PH (220 volt 60hz), 3 PH (220/440 60 hz), OSHA guard for carbide blades, 1" arbor, Spindle RPM 4400, 4 bolt mount, Manual switch, Please specify voltage, Weight: 240 lbs.

**HS14ASPH**



**HS14ASPH** 12-14" blade, Non-ferrous arm assy., 5 HP, 1PH 220V, 5HP, 3PH (220/440) semi-automatic, air/oil down feed, OSHA guard for carbide tipped blades, 1" arbor, Spindle RPM 4400, 4 bolt mount, Manual switch, Please specify voltage, Weight: 250 lbs.

**K10AS** (Not shown), 10" arm assy., abrasive wheel only, 3 HP, 1PH(110/220 volt), 3 PH (220/440), manual switch, 5/8" arbor, spindle RPM 3450, 4 bolt mounting, Less wheel, Please specify voltage, Weight: 84 lbs.

**K12-14AS** (Not Shown), 12-14" arm assy., abrasive wheel only, 5 HP, 1 PH (220 volt 60 hz), 3 PH. (220/440 volt 60 hz.), manual switch, 1" arbor, Spindle RPM 4400, 4 bolt mounting, less wheel, Please specify voltage, Weight: 200 lbs.

**HS14ASDC** (Not Shown), 12-14" blade, 5 HP, 1 PH( 220 volt 60 hz) 3 PH (220/440 volt 60 hz), Dry cut carbide blade for 1/4" wall angle, tubing, structural, Spindle RPM 1300., 1" arbor, 4 bolt mount, Manual switch, less blade. Please specify voltage, Weight: 240 lbs.

## ABRASIVE MITERING SAWS



**MODEL KM20-22V-15**

- 20" or 22" wheel.
- 1" spindle, 2500 RPM.
- Dual air chain vises.
- Capacities: Straight 4" solid, 6" most shapes;
- 3" solid, 5" most shapes at 45°.
- Covered hood with vacuum base.
- Dimensions — L 52" x W 63" x H 68".
- Mitres 45° left or right.

**MODEL KM20-22V-15** 15 HP saw duty, 3 phase (220/440V). Magnetic starter. Air-operated chain vise standard. Uses 20" abrasive wheel (not included). 1" wheel arbor. Built-in dust collector in base with hood, dust bag, 1200 CFM. Wt. 1700 lbs.

**MODEL KM20-22V-20** Same as above, with 20 HP motor, 3 phase (220/440V); please specify voltage. Wt. 1800 lbs.



# BELT SANDERS

**MODEL 1SM**



**MODEL 1SM** 1/3 HP motor, 1 PH, 1725 RPM. 1" x 42" belt, 4" contact wheel, tilt table. Vertical sander only. 1800 SFPM. Wt. 34 lbs.

**MODEL 1SMV** Enclosed guard, DCV-4 vacuum base. Wt. 95 lbs.

**MODEL 2FSM**



**MODEL 2FSM** 1/2 HP motor, 1 PH, 3450 RPM. 2" x 48" belt, 5" contact wheel, tilt table and removable platen. Full hinged guard for quick belt change. Vertical or horizontal position. 4500 SFPM. Wt. 50 lbs.

**MODEL 2FS**



**MODEL 2FS** Less motor. Vertical or horizontal. 2" x 48" belt, tilt table, 5" contact wheel, removable platen and pulley V-belt. Wt. 24 lbs.

**MODEL 2FS72**



**MODEL 2FS72** Less motor. Similar to the 2FS only 2" x 72" belt and 8" contact wheel. Wt. 28 lbs.

**MODEL 2FSMV**



**MODEL 2FSMV** 2FSM sander mounted on DCV-4 dust collector. 1 PH 110V. Wt. 120 lbs.

## BUILT-IN DUST COLLECTORS

**MODEL S4SV**



**MODEL S4SV** 4" x 36" belt sander with dust collector, cord and switch. 1/2 HP, 1 PH, 3450 RPM (1 HP motor available). Wt. 120 lbs.

**MODEL S4S**



**MODEL S4S** The all-purpose sander for metal, wood and plastics. Use in vertical or horizontal position. 1/2 HP, 1 PH TEFC motor. 3450 RPM (1 HP motor available). 4" x 36" belt with full OSHA guard, easy opening side door for belt change. Wt. 50 lbs.

**MODEL S4** sander without full safety guard. (1 HP motor available). Wt. 46 lbs.

# BELT SANDERS

- 4" x 60" belt.
- 1 HP, 1 PH or 3 PH.
- Direct drive.
- 3450 RPM — 4" pulley.
- Platen — reversible 4" x 17"
- Table — Cast iron 4" x 6".
- 3600 SFPM.
- Full OSHA guard.
- Easy tracking.
- Quick belt change.
- Horizontal model available.
- Vacuum base 400 CFM.
- Dimensions — L 18" x W 26" x H 60".

**MODEL S460V**



**MODEL S460D**

- 4" x 60" belt.
- Direct drive.
- Reversible platen 4" x 17".
- Table — 4" x 6".
- Full OSHA guard.
- Easy tracking.
- Quick belt change.
- Dimensions — L 14" x W 16" x H 33".

**MODEL S460D** 1 HP, 1 PH or 3 PH. Please specify voltage and phase. Manual switch. Wt. 290 lbs.



**HEAVY-DUTY!**

**MODEL S460V** 1 HP, 1 PH or 3 PH, manual switch, please specify phase and voltage. DCV-6 vacuum base. Wt. 485 lbs.

**MODEL S4SWB**



- 4" x 36" wet benchtop.
- Pre-set belt tension.
- Quick change belt.
- Internal pump.
- Platen 4" x 6".
- Dimensions — L 20" x W 20" x H 12".
- Good for met labs.

**MODEL S4SWB** 4" x 36" wet, 1/2 HP, 1 PH TEFC. Wt. 150 lbs.

**MODEL S4SWBD** 4" x 36" wet, belt and 8" disc. 1/2 HP, 1PH TEFC. Wt. 180 lbs.

**RUGGED!**



**MODEL S460W**

- Heavy stand.
- Magnetic switch
- Spindle RPM — 2800.
- Flood coolant, 10 gal., 1/3 HP, 20 GPM.
- Platen — 4" x 17".
- Work table — 4" x 6".
- Dimensions — L 36" x W 24" x H 63".
- Available vertical or horizontal (specify when ordering).

**MODEL S460W** 4" x 60" wet belt sander. 3 HP, 1 PH or 3 PH, saw duty motor. Please specify voltage. Coolant pump and tank with splash guards. Magnetic switch. Wt. 485 lbs.

# 6" BELT SANDERS

## MODEL S6MS

3 HP  
or  
5 HP

- 6" x 48" belt.
- Variable position.
- Direct drive (coupling).
- Cast iron frame.
- Quick-belt release.
- Full safety guard.
- Heavy-duty steel stand.
- 3 HP motor – 3450 RPM.
- 1 PH or 3 PH .
- Manual switch.
- 3500 SFPM.
- Reversible platen  
6-1/2" x 14".
- Cast iron table  
6" x 10", 1/2" x 1/8" slot.



## MODEL S6MV



**MODEL S6MS** 6" sander with 3 HP saw duty motor and manual switch and stand. 1 PH or 3 PH; please specify. Wt. 230 lbs. Dimensions: L 22" x W 14" x H 56".

**MODEL S6MS-5** 5 HP, 3PH, other features same as above.

**MODEL S660MS** 6" x 60", other features same as above.

**MODEL S6MV** 6" belt sander with heavy-duty enclosed stand and vacuum dust collector. Wt. 400 lbs. Dimensions: L 27" x W 18" x H 52".

**MODEL S660MV** 6" x 60", other features same as above.

## MODEL S6MW

Horizontal/  
Vertical



## WET BELT SANDERS

- 3 HP, 1 PH or 3 PH
- 3450 RPM
- Steel platen - 6 1/2" x 14"(S6MW)
- Steel platen - 6" x 19 1/2"(S660MW)
- 2800 SFPM.
- Cast iron table with 1/2" x 1/8" slot.
- Cast iron frame.
- Quick belt release.
- Full safety guard.
- Magnetic switch.
- Constant spring tension.
- Heavy-duty base.
- Coolant pump and tank, 10 gal.,  
1/3 HP

## MODEL S660MW



**MODEL S6MW** 6" x 48" belt, 3 HP saw duty, 1 PH or 3 PH. Magnetic switch and built-in coolant system. Please specify voltage. Wt. 475 lbs. Dimensions: L 37" x W 24" x H 55".

**MODEL S660MW** 3 HP saw duty, 1 PH or 3 PH. Magnetic switch. 10-gallon coolant pump and tank. 6" x 60" belt. Dry models available. Wt. 500 lbs. Dimensions: L 42" x W 24" x H 65".



# COMBINATION SANDERS

## COMBINATION GRINDER/SANDERS

**MODEL 2SK7**



**MODEL 2SK7** Two machines in one. 7" bench grinder (1/2 HP 110V) with a 2" x 48" belt sander. Use in vertical or horizontal position. Has tilt table, contact wheel, removable platen. 3450 RPM. Wt. 50 lbs.

### BELT MACHINE...

**Work Table** – Cast iron 6" x 10" with 1/2" x 1/8" slot.  
**Platen** – Steel 6-1/2" x 14".  
**Belt** – 6" x 48", 2800 SFPM.  
 L 14" x W 19" x H 58".

### DISC MACHINE...

**Work Table** – Cast iron 8" x 14".  
**Disc** – Solid aluminum 12".  
**Speed** – 2500 SFPM.

**MODEL S612V-1 6" BELT/12" DISC COMBINATION SANDER.** 3 HP, 1 PH TEFC motor, 220V only, enclosed stand with built-in 100 CFM dust collector. Manual switch-overload protection. Wt. 500 lbs.

**MODEL S612V-3 6" BELT/12" DISC COMBINATION SANDER.** Same as above, only 3 PH motor. 220 or 440V, please specify. Wt. 500 lbs.

**MODEL S612-1 6" BELT/12" DISC COMBINATION SANDER.** 3 HP, 1 PH, 220V only. TEFC motor with switch, enclosed stand; less dust collector. Wt. 380 lbs.

**MODEL S612-3 6" BELT/12" DISC COMBINATION SANDER.** 3 HP, 3 PH, 220/440V, please specify. TEFC motor with switch, enclosed stand; less dust collector. Wt. 380 lbs.

**MODEL MG-6.** Mitre gauge for belt and disc sander.

**MODEL S612V**

**3 HP!!**

**VACUUM BASE!**



**MODEL DS10-2M**



**MODEL DS10-4S**



**MODEL 1SK6**



**MODEL 1SK6** Similar to above only with 1/3 HP with 6" wheel and 1" x 42" belt. 3450 RPM. Wt. 32 lbs.

**MODEL DS10-2M** 10" disc with 2" belt sander. 1/2 HP, 1 PH TEFC motor. Wt. 76 lbs.

**MODEL DS10-4S** 10" disc with 4" belt sander. 1/2 HP, 1 PH TEFC motor, full OSHA belt guard. Wt. 84 lbs.

**MODEL DS10-4** Same as above without full OSHA belt guard. Wt. 76 lbs.

# BELT GRINDERS

## MODEL BG272

- Open area design for easy access.
- Throat dimensions: 10" H x 13" D.
- Dimensions L 24" x W 12" x H 24".
- 7200 SFPM belt speed.
- 5" lower contact wheel.
- Easy belt tracking.
- Direct drive.



**MODEL BG272 2" x 72"** belt grinder. Bench model, 1 HP TEFC, 1 PH 110/220 volt motor. Manual switch. Wt. 80 lbs.

**MODEL BG272S.** Same as above but with heavy-duty stand legs. Wt. 150 lbs.

## MODEL BG260HS

### Heavy-duty direct drive

- 2" x 60" belt.
- 3 HP, 1 PH, 110/220 or 3 PH 220/440, 3450 RPM.
- 8" contact wheel. Right side clear for corner sanding.
- 5400 SFPM.
- 2" x 12" x 1/2" reversible platen.
- Easy tracking.
- 2" x 3" work table, dual purpose for contact wheel and top platen.
- Manual switch.
- Spring-loaded belt tension.
- Quick belt change.
- Dimensions — L 23" x W 16" x H 40"



**MODEL BG260H 2" x 60" BELT GRINDER.** Horizontal bench model. 3 HP, 1 PH or 3 PH; please specify. Wt. 95 lbs.

**MODEL BG260HS.** Same as above but with heavy-duty stand legs. Wt. 150 lbs.

**MODEL BG260HV.** Same as BG260H only mounted on DCV-6 dust collector. Wt. 390 lbs.

# 3" X 90" / 4" X 90" BELT GRINDERS

- 3" x 90" belt (4" optional).
- 8" contact wheel.
- Direct drive.
- Air tensioning.
- Versatile.
- Multi-position through vertical.
- Built-in vacuum (optional).
- 2 HP, 1 PH 110/220V.
- 3 HP, 3 PH 220/440V.
- 40 lbs. shop air needed.
- 3" x 24-1/2" steel reversible platen.
- 6900 SFPM.
- W 18" x D 48" x H 47"



**MODEL KS390**  
**MODEL KS490**

**MODEL KS390** 2 HP, 1 PH or 3 HP, 3 PH; please specify phase and voltage. Manual switch, air gauge with valve and regulator. Wt. 380 lbs.

**MODEL KS390V** Same as above with dust collector built into base. Wt. 400 lbs.

**MODEL KS490** Same as KS390 but with 4" belt. Wt. 380 lbs.

**MODEL KS490V** Same as KS390V but with 4" belt. Wt. 400 lbs.

**MODEL KS390HV**  
**MODEL KS490HV**

- W 18" x D 26" x H 42"



**MODEL KS390HV-5** 5 HP, 3 PH belt sander 220/440V; please specify. Horizontal only. Manual switch. Mounted on DCV-6 dust collector. 400 CFM. Wt. 450 lbs.

**MODEL KS490HV-5** Same as KS390HV-5 but with 4" belt. Wt. 450 lbs.

## MULTI-PURPOSE BELT GRINDER

### One machine for:

- Grinding.
- Shaping.
- Contouring.
- Flat work.
- Angles.
- Snagging.
- Roughing.
- Versatile – quick change contact wheel (3" and 1-1/2") with various angles. Easy to change.
- L 27" x W 18" x H 40".
- SFPM 5400.
- 2" x 72" belt.

Platen rotates 360° for many different shapes of sanding.



### MODEL S272V



**MODEL S272** 2" X 72" belt grinder. Bench model, 1 HP. 1 PH or 3 PH, please specify. Manual switch. Wt. 110 lbs.

**MODEL S272S.** Same as above but with heavy-duty stand legs. Wt. 170 lbs.

**MODEL S272V.** Same as S272 only mounted on DCV-6 dust collector. Wt. 350 lbs.

**MODEL S272VS.** Variable speed motor.

**MODEL CW-5.** 5" contact wheel for model S272 series.

## 6" X 90" BELT GRINDER

- 6" w x 8" diameter 70 duro serrated contact wheel.
- 6" x 24" platen for flat work.
- 7200 SFPM.
- 400 CFM vacuum base.
- Air belt tension.
- Manual switch.
- Spark chute horizontal/vertical.
- Dimensions – W 18" x D 26" x H 42".

**MODEL KS690** 5 HP, 3PH TEFC motor, 220 or 440 volt (please specify). No vacuum base. Wt. 400 lbs.

**MODEL KS690HV** 5 HP, 3PH TEFC motor, 220 or 440 volt (please specify). Vacuum base. Wt. 600 lbs.

### MODEL KS690HV





# 8" SANDERS

## VERTICAL OR HORIZONTAL FOR ABRASIVE MACHINING WET OR DRY

- 8" x 60" belt.
- 7-1/2 HP, 3 PH motor.
- Twin belt drive.
- Replaceable platen.
- Cast iron table 8" x 12".
- Platen working surface 8" x 13".
- Dimensions — L 25" x W 25" x H 62".



**MODEL S8W**

Air tensioning on belt, 40 to 50 lbs. of shop air. Air gauge and valve included.

### HEAVY-DUTY



**MODEL S8HD**

**MODEL S8D 8" VERTICAL SANDER, DRY.** 7-1/2 HP, 3 PH motor. Magnetic switch with jog button. 1725 RPM, 3500 SFPM. Wt. 645 lbs.

**MODEL S8W 8" VERTICAL SANDER, WET.** 7-1/2 HP, 3 PH motor. Magnetic switch with jog button. Heavy-duty coolant pump with switch. Wt. 760 lbs.

**MODEL S8HD 8" HORIZONTAL SANDER, DRY.** 7-1/2 HP, 3 PH motor. Magnetic switch with jog button. Wt. 900 lbs.

**MODEL S8HW 8" HORIZONTAL SANDER, WET.** 7-1/2 HP, 3 PH motor. Same as above but with 10 gal. coolant pump with tank.

# 10" BELT SANDERS



**MODEL S10D**

**AVAILABLE  
AS  
VERTICAL  
OR  
HORIZONTAL**

**10 HP  
RUGGED!**

- 10" x 90" belt.
- 3400 SFPM.
- Steel platen 29" x 10".
- Work surface 28" x 10".
- Cast iron table 14" x 18".
- Table tilt 45° down, 15° up.
- Air tension on belt.
- 10 HP, 3 PH, TEFC.
- Mag controls with jog.
- Dimensions — L 39" x W 28" x H 70".

**MODEL S10D 10" VERTICAL SANDER, DRY.** 10 HP, 3 PH motor. Magnetic switch with jog button. 1725 RPM, 3500 SFPM. Wt. 1160 lbs.

**MODEL S10W 10" VERTICAL SANDER, WET.** 10 HP, 3 PH motor. Same as above but with built-in coolant system. Wt. 1550 lbs.

**MODEL S10HD 10" HORIZONTAL SANDER, DRY.** 10 HP, 3 PH motor. Wt. 900 lbs.

**MODEL S10HW 10" HORIZONTAL SANDER, WET.** 10 HP, 3 PH motor. Same as above only with built-in coolant system. Wt. 950 lbs.

# 14" SANDERS

**HARD-COATED PLATENS AVAILABLE  
SPECIAL MACHINES AVAILABLE,  
OPTIONAL: VARIABLE SPEED**

*Other sizes available*

## **MODEL S14HW**

- 14" x 103" belt.
- 3400 SFPM.
- Steel platen 14-1/2 x 36".
- Work surface 14" x 32".
- Air tension on belt.
- 20 HP, 3 PH, TEFC.
- Mag controls with jog.
- L 64" x W 31" x H 35".

### **MODEL S14HD 14" HORIZONTAL SANDER, DRY.**

20 HP, 3 PH motor. Wt. 1800 lbs.

### **MODEL S14HW 14" HORIZONTAL SANDER, WET.**

20 HP, 3 PH motor. Same as above only with built-in coolant system. Wt. 1900 lbs.



## **MODEL S14D**

- 14" x 103" belt.
- Steel platen 14-1/2 x 36".
- Work surface 14" x 32".
- Tilt worktable 14" x 18".
- Mag controls with jog.
- Air belt tensioning.
- 3400 SFPM.
- L 46" x W 31" x H 84".

**MODEL S14D 14" VERTICAL SANDER, DRY.** 20 HP, 3 PH motor. Wt. 1750 lbs.

**MODEL S14W 14" VERTICAL SANDER, WET.** 20 HP, 3 PH motor. Same as above only with built-in coolant system. Wt. 1850 lbs.

# DISC SANDERS

**MODEL DS10**



- Heavy-duty, all steel.
- Tilt table, 45° down, 15° up.
- Optional MG10 mitre gauge.
- 10" aluminum disc, 5/8" arbor.

**MODEL DS10** 10" disc sander. 6" x 11" table. 1/2 HP, 110/220V, 1 PH TEFC motor. Wt. 48 lbs.

**MODEL DS12**



- Heavy-duty, all steel.
- Tilt table.
- Optional MG12 mitre gauge.
- 12" aluminum disc, 5/8" arbor.

**MODEL DS12** 12" disc sander. 8" x 14" table. 1 HP, 110/220V, 1 PH TEFC motor. Wt. 85 lbs.

**MODEL DS20**



**MODEL DS20** 20" disc sander, 2HP, 3 PH, 220 or 440V; 1-1/2 HP, 1 PH 110 or 220V, reversing switch. 1740 RPM, tilt table w/mitre gauge. Wt. 550 lbs.

**MODEL DS12V**



**MODEL DS12V** 12" disc sander, complete with enclosed stand and vacuum dust collector. 1 HP, 1 PH 110 volts. Wt. 150 lbs.

**MODEL DS10V**



**MODEL DS10V** 10" disc sander, complete with enclosed stand and vacuum dust collector. 1/2 HP, 1 PH 110 volts. Wt. 110 lbs.

**BUILT-IN  
DUST  
COLLECTOR**



# DUST COLLECTORS



**MODEL DCV-1**

**MODEL DCV-1** Dust collector unit for heavy-duty applications. Use with 20" abrasive saws and 8" belt sanders. Capacity 1200 CFM. Dust bag furnished with unit. 3 PH. 220 or 440V, please specify. Wt. 300 lbs. Dimensions: L 24" x W 24" x H 40".



**MODEL DCV-4**

**MODEL DCV-4** Dust collector used with 4" sander, could be used with 2" machines. 1 PH only. Capacity 100 CFM. Dust bag furnished with each unit. Wt. 58 lbs. Dimensions: L 12" x W 14" x H 32".



**MODEL DCV-6**

**MODEL DCV-6** Dust collector with filter. 1 HP, 1 PH or 3 PH. Capacity 400 CFM. Used for 6" sanders and various other models. Wt. 240 lbs. Dimensions: L 27" x W 18" x H 28".

# DOWNDRAFT TABLE / DUST COLLECTOR



**MODEL DCV-8**



## **Model DCV-8**

- Downdraft table for dust, smoke & vapors
- 800 CFM
- 30" x 34" table top.
- 55 sq. ft. flame retardant cotton sateen filter bags.
- 12 ga. steel construction
- Manual foot pedal bag cleaning shaker.
- 68 dba noise level.
- Removable dust drawer
- Casters for easy movement.

## **MODEL DCV-8**

800 CFM, 1 hp motor, 1 ph, 110 volt.  
Wt. 355 lbs., Dimensions: L 34" x W 30" x H 64"

# VIBRATORY FINISHER



**MODEL KVF3**

- 3.3 cubic ft. capacity.
- Quiet operation.
- 500 lbs capacity.
- Compact design.
- Portable – on wheels.
- Vibra action rotates media.
- Easy to load and unload.
- 110 VAC.
- Rugged construction!
- Steel tub w/cast urethane lining.
- Coolant tank and pump.
- One hour timer switch.

**SPECIFICATIONS:**

Cabinet: 36" W x 27" D x 36" H  
 Tub: 28" L x 15" W x 15" H  
 Motor: 3/4 HP, 1 phase, 110 VAC  
 Shipping weight: 640 lbs.  
 Made in U.S.A.

**Great for polishing, deburring and finishing!**

# ACCESSORIES / STANDS

**GRAVITY ROLLER CONVEYOR**



**MODEL KC5**

**MODEL KCL SUPPORT LEGS**



**AV-18 AIR VISE**



**KW-1 SPINDLE WRENCH**



**12-W STAND**



**12-P STAND**

Ht. 32"  
 Table 21" x 12"  
 Wet 29" x 20"



**MODEL S-346**

**KW-1** Spindle wrench for 1" arbor saws. 12"-26" saws. 5#.  
**AV-18** Fits 10"-18" straight cut saws. Requires 0-100 PSI air. #25.  
**AV-20** Fits 20" straight cut saws. Same as above.  
**AV-26** Fits 26" straight cut saws. Same as above.

**KC5 GRAVITY FEED CONVEYOR** 1.9" diameter rollers, 6" centers, 3000# capacity for each 5' section.

**KCL** Bolt together C channel support legs.

**STANDS**

12-P Steel stand for 7" saw, 4" belt sander, or other tools. Wt. 62 lbs.  
 12-O Steel stand, open top, for K10B saw. Wt. 56 lbs.  
 12-W Steel stand, tray top for coolant. For 7", 8" and 10" saws. Wt. 82 lbs.

**STOCK STAND MODEL S-346**

8" steel roller. Maximum height 40", minimum height 30".

# INDEX FIXTURES...5C COLLET HOLDING FIXTURES

## UNIVERSAL-INDEXER

### The Most Versatile Accessory For Your Shop

- Takes a 4" universal chuck — 3- or 6- jaw or 5C collets
- Head can be angled from minus 0° to 100°+
- Indexes quickly, easily—spindle locks in positive position
- Numerous combinations by changing ground indexing-spacer
- Can be dismantled in seconds for easy cleaning.
- For drill presses, milling machines, grinders, layout work
- With 24 space ringless chuck

MODEL	DESCRIPTION	WT. (lbs.)
A1	Universal-Indexer (less chuck) with 24 Space Ring.....	24
AT	Standard Tailstock.....	11
1034	4" 3-Jaw Universal Chuck.....	4.5
AS	Stub Arbor 1" 10 Thrd. ....	1
AR-0	Index Ring-Blank .....	0.25
AR-20	Index Ring-20 Spaces .....	0.25
AR-36	Index Ring-36 Spaces .....	0.25
AD-5C	Draw-in Nut for 5C Collets .....	0.25



A1

Made in USA.

## RTBA



### 6" INDEX TABLE

- Complete with 6" chuck and 24 indexing ring
- Nondeflecting spindle lock
- Spindle can be locked in any position without pin engaged
- Numerous index combinations by changing of index ring—up to 36 spaces
- 5° marks on spindle
- Made in USA

MODEL	DESCRIPTION	WT. (lbs.)
RTBA	Index Table-24 Space with 6" 3-Jaw chuck.....	45
RTBB	Index Table-24 Space with 6" 6-Jaw chuck.....	46
RT	Index Table-24 Space (less chuck) Plain Platen-1" Hole .....	22
AR-0	Index Ring, Blank.....	0.25
AR-20	Index Ring, 20 Space .....	0.25
AR-36	Index Ring, 36 Space .....	0.25
ARS	Any Division up to 44 .....	0.25
IAT	Tailstock with Riser Block .....	12

## INDEX FIXTURE — for 5C Collets

- For drilling, milling, grinding, and locating angles
- Index plate easily changed
- Precision ground spindle
- Plate can be bolted to top for drill bushing
- Use in vertical position with angle plate
- Rugged, high-quality
- Model 5C complete with 24 space ring and 5C draw nut
- Made in USA

MODEL	DESCRIPTION	WT. (lbs.)
5C	Index Fixture with 24 Space Ring and Draw Bar (less collets) .....	15
AT	Standard Tailstock .....	10
AR-0	Index Ring, Blank.....	0.25
AR-20	Index Ring, 20 Space .....	0.25
AR-36	Index Ring, 36 Space .....	0.25
AS	Stub Arbor 1"-10 Thread .....	1
LC	Lever Collet Closer (shown below) .....	1

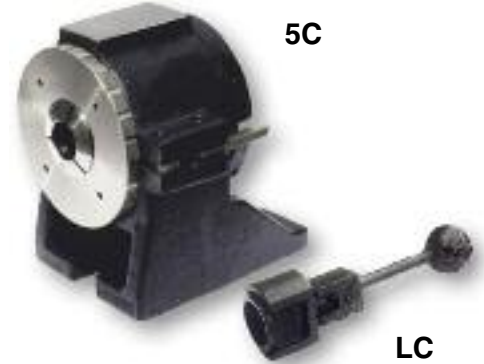

5C

LC



AO5C

### AIR-OPERATED 5C COLLET HOLDER

- Versatile
- Accurate
- Hardened and ground spindle
- Collets held dead length
- Two position- Horizontal / Vertical
- For drill presses, milling machines, grinders
- Dimensions: 3-1/2" high, 4-3/4" diameter, 2-1/2" base to center line
- 0-100 PSI shop air
- Made in USA

MODEL	DESCRIPTION	WT. (lbs.)
AO5C	Air-Operated 5C Collet Holder.....	7
AR-62	Foot-Operated Valve.....	6
125 V	3-Way Lever Type Valve.....	1

10C



### COLLET HOLDING FIXTURE - for 5C Collets

- Collets held dead length
- Hardened and ground spindle, two position, heavy casting
- Made in USA

MODEL	DESCRIPTION	WT. (lbs.)
10C	Holding Fixture for 5C Collets.....	18

### HOLD O.D. IN POWER/MANUAL CHUCK!

1CC



**DEAD LENGTH!**

**NO SET-UP! HEX KEY INCLUDED.**

**1CC COLLET CHUCK** For short runs using a 5C collet, chuck this collet holder -and you're ready to go! Lock, 1/2 turn and release at the front; heavy-duty; all-steel, hardened and ground; time-saving; drilled and tapped holes at rear of collet chuck for mounting to a plate or AT1CC. Mount in: 4th axis/vertical/horizontal mills/ machining centers. Made in USA.

MODEL	DESCRIPTION	WT. (lbs.)
1CC	Collet Chuck.....	6



# ABRASIVE BELTS, DISCS, WHEELS

## ALUMINUM OXIDE, WET, DRY BELTS



## PSA ADHESIVE



## GENERAL PURPOSE, WET, DRY, NON-REINFORCED



## ABRASIVE SANDING BELTS

SIZE	50 GRIT	80 GRIT	100 GRIT
1 x 42 DRY BELTS	KB14250	KB14280	KB142100
2 x 48 DRY BELTS	KB24850	KB24880	KB248100
2 x 60 DRY BELTS	KB26050	KB26080	KB260100
2 x 72 DRY BELTS	KB27250	KB27280	KB272100
3 x 90 DRY BELTS	KB39050	KB39080	KB390100
4 x 36 DRY BELTS	KB43650	KB43680	KB436100
4 x 60 DRY BELTS	KB46050	KB46080	KB460100
4 x 60 WET BELTS	KWB46050	KWB46080	KWB460100
4 x 90 DRY BELTS	KB49050	KB49080	KB490100
6 x 48 DRY BELTS	KB64850	KB64880	KB648100
6 x 48 WET BELTS	KWB64850	KWB64880	KWB648100
6 x 60 DRY BELTS	KB66050	KB66080	KB660100
6 x 60 WET BELTS	KWB66050	KWB66080	KWB660100
6 x 90 DRY BELTS	KB69050	KB69080	KB690100
8 x 60 DRY BELTS	KB86050	KB86080	KB860100
8 x 60 WET BELTS	KWB86050	KWB86080	KWB860100
10 x 90 DRY BELTS	KB109050	KB109080	KB1090100
10 x 90 WET BELTS	KWB109050	KWB109080	KWB1090100
14 x 103 DRY BELTS	KB1410350	KB1410380	KB14103100
14 x 103 WET BELTS	KWB1410350	KWB1410380	KWB14103100

## ABRASIVE SANDING DISCS

SIZE	50 GRIT	80 GRIT	100 GRIT
10" DRY DISCS	KD1050	KD1080	KD10100
12" DRY DISCS	KD1250	KD1280	KD12100
20" DRY DISCS	KD2050	KD2080	KD20100

## ABRASIVE WHEELS (SPECIAL WHEELS AVAILABLE)

SIZE	NON-REINFORCED	DRY CUTTING REINFORCED	WET CUTTING REINFORCED
7 x 1/16 x 1/2	KAB7N	—	—
8 x 1/16 x 1/2	KAB8N	—	—
10 x 3/32 x 5/8	KAB10N	KAB10R	—
12 x 1/8 x 1	—	KAB12R	—
14 x 1/8 x 1 (1725)	—	—	KW14R1725
14 x 1/8 x 1 (2590)	KW142590	KAB14R	—
16 x 5/32 x 1	—	KAB16R	—
18 x 5/32 x 1	—	KAB18R	—
20 x 5/32 x 1	—	KAB20R	KW20R1725
26 x 5/32 x 1	—	KAB26R	KW26R1725
30 x 5/32 x 1-3/4	—	KAB30R	KW30R1725



**ABRASIVE SAWS ♦ BELT SANDERS ♦ INDEXING HEADS ♦ LATHE CHUCKS**

KALAMAZOO INDUSTRIES, INC., 6856 EAST K AVENUE, KALAMAZOO, MI 49048  
 PHONE (269) 382-2050 FAX (269) 382-0790 [www.kalamazooindustries.com](http://www.kalamazooindustries.com)